



US00D574955S

(12) **United States Design Patent**  
**Lash et al.**

(10) **Patent No.:** **US D574,955 S**  
(45) **Date of Patent:** **\*\* Aug. 12, 2008**

(54) **PORTION OF NERVE ROOT RETRACTOR WITH SENSOR**

(75) Inventors: **Robert E. Lash**, Redwood City, CA (US); **Jimmy Jian-min Mao**, Fremont, CA (US)

(73) Assignee: **ViOptix, Inc.**, Fremont, CA (US)

(\*\*) Term: **14 Years**

(21) Appl. No.: **29/284,745**

(22) Filed: **Sep. 14, 2007**

**Related U.S. Application Data**

(63) Continuation-in-part of application No. 29/281,422, filed on Jun. 22, 2007.

(51) **LOC (8) Cl.** ..... **24-02**

(52) **U.S. Cl.** ..... **D24/135**

(58) **Field of Classification Search** ..... D24/135;  
600/206, 210, 245; 604/902, 35, 540; 433/95,  
433/96

See application file for complete search history.

(56) **References Cited**

**U.S. PATENT DOCUMENTS**

3,394,700	A	7/1968	Yamamoto	
4,049,000	A	9/1977	Williams	
4,190,042	A	2/1980	Sinnreich	
4,226,228	A *	10/1980	Shin et al.	600/206
D275,227	S	8/1984	Garner, Jr.	
4,597,382	A	7/1986	Perez, Jr.	
4,738,248	A	4/1988	Ray	
4,919,616	A	4/1990	Croll	
4,959,067	A	9/1990	Muller	
D312,306	S	11/1990	Michelson	
D318,116	S	7/1991	Michelson	
5,123,403	A	6/1992	Lavyne	
5,520,611	A	5/1996	Rao et al.	
5,769,781	A *	6/1998	Chappuis	600/202
5,803,904	A	9/1998	Mehdizadeh	
5,891,018	A	4/1999	Wells	
D411,883	S *	7/1999	Farascioni et al.	D24/135

D430,668	S	9/2000	Koros et al.	
D433,134	S	10/2000	Pitesky	
D442,687	S	5/2001	Schulz	
D443,056	S	5/2001	Koros et al.	
D453,377	S	2/2002	Schollhorn et al.	
D457,957	S	5/2002	Sanford et al.	
6,416,465	B2	7/2002	Brau	
6,875,173	B2 *	4/2005	Suddaby	600/210
D510,768	S *	10/2005	Farley	D24/135
6,994,548	B2	2/2006	Perret, Jr.	
7,226,413	B2	6/2007	McKinley	

**OTHER PUBLICATIONS**

Nerve Root Retractors, Codman Surgical Product Catalog 380-385 (2004).

\* cited by examiner

*Primary Examiner*—Ian Simmons  
*Assistant Examiner*—Christopher Lee  
(74) *Attorney, Agent, or Firm*—Aka Chan LLP

(57) **CLAIM**

The ornamental design for a portion of a nerve root retractor with sensor, as shown and described.

**DESCRIPTION**

FIG. 1 is a perspective view of a first embodiment for a portion of a nerve root retractor with sensor.

FIG. 2 is a right side view thereof;

FIG. 3 is a left side view thereof;

FIG. 4 is a top view thereof;

FIG. 5 is a front view thereof; and

FIG. 6 is a first alternate bottom view of the design.

FIG. 7 is a second alternate bottom view of the design.

FIG. 8 is a third alternate bottom view of the design.

FIG. 9 is a fourth alternate bottom view of the design.

FIG. 10 is a fifth alternate bottom view of the design.

FIG. 11 is a sixth alternate bottom view of the design.

FIG. 12 is a seventh alternate bottom view of the design.

FIG. 13 is an eighth alternate bottom view of the design.

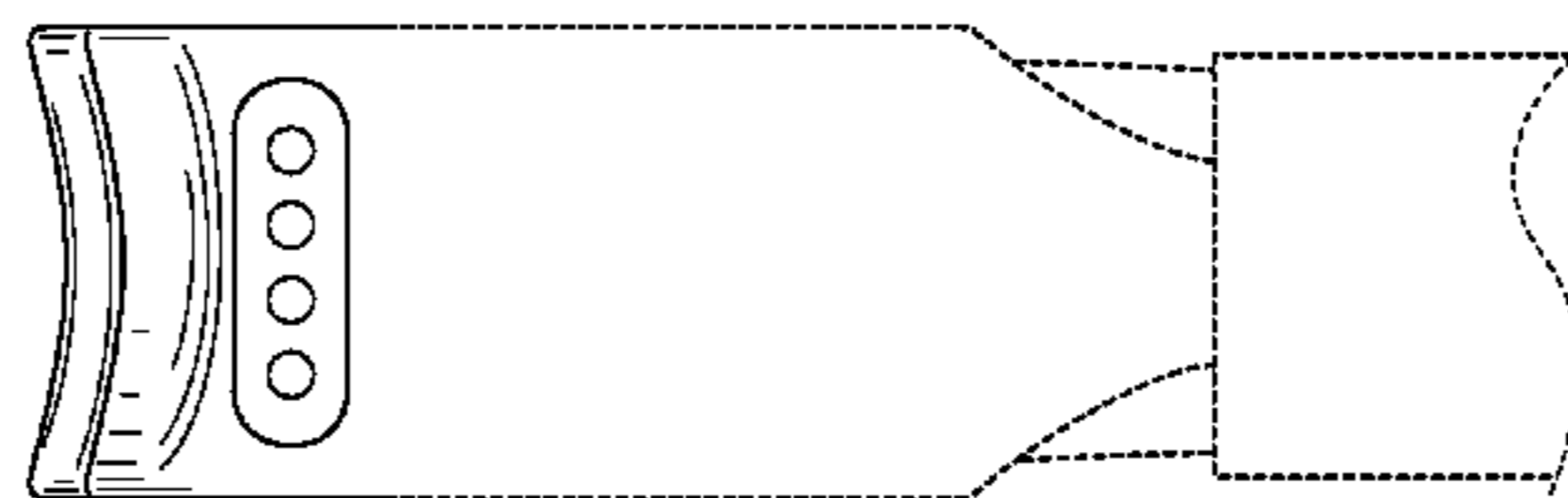
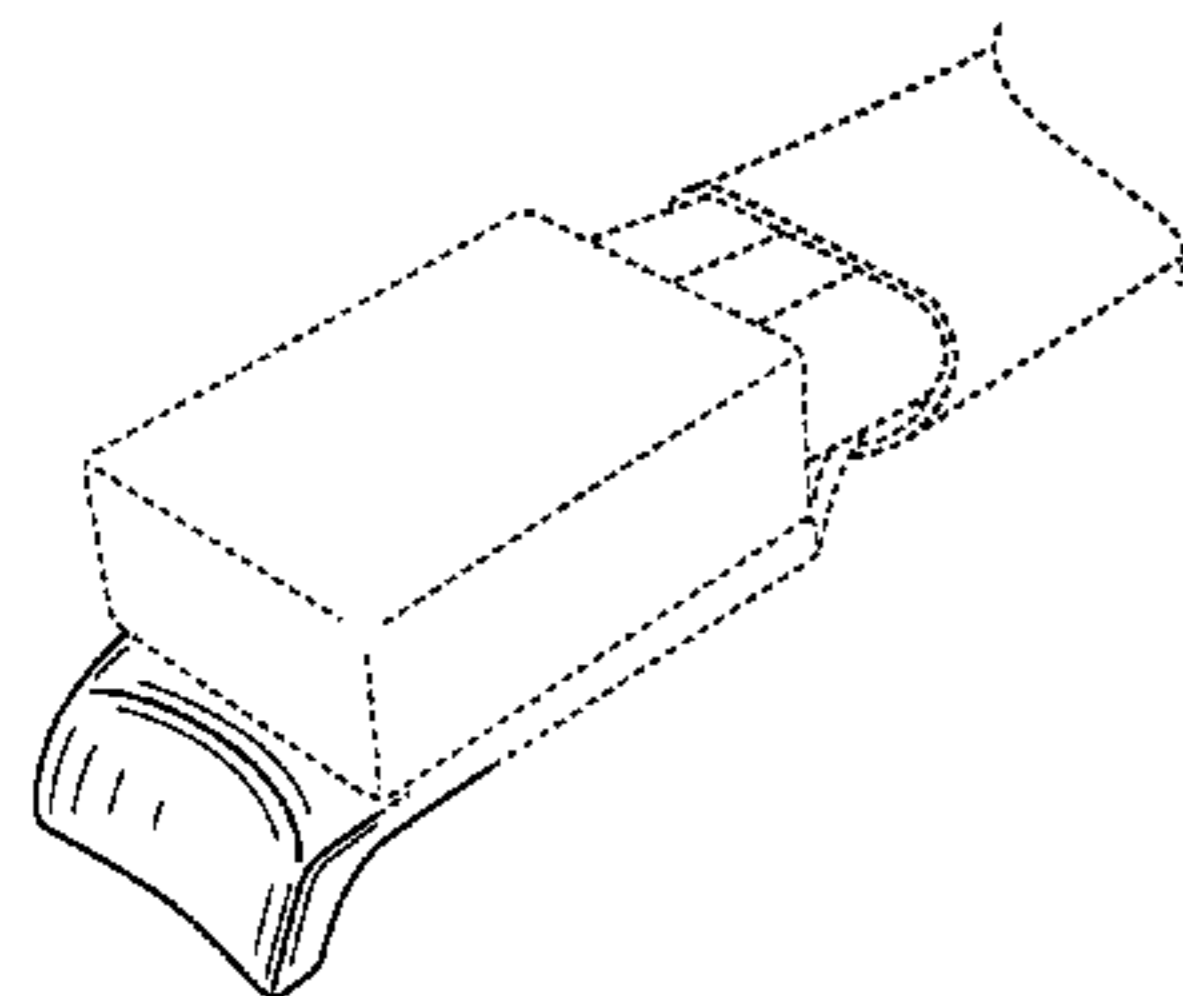
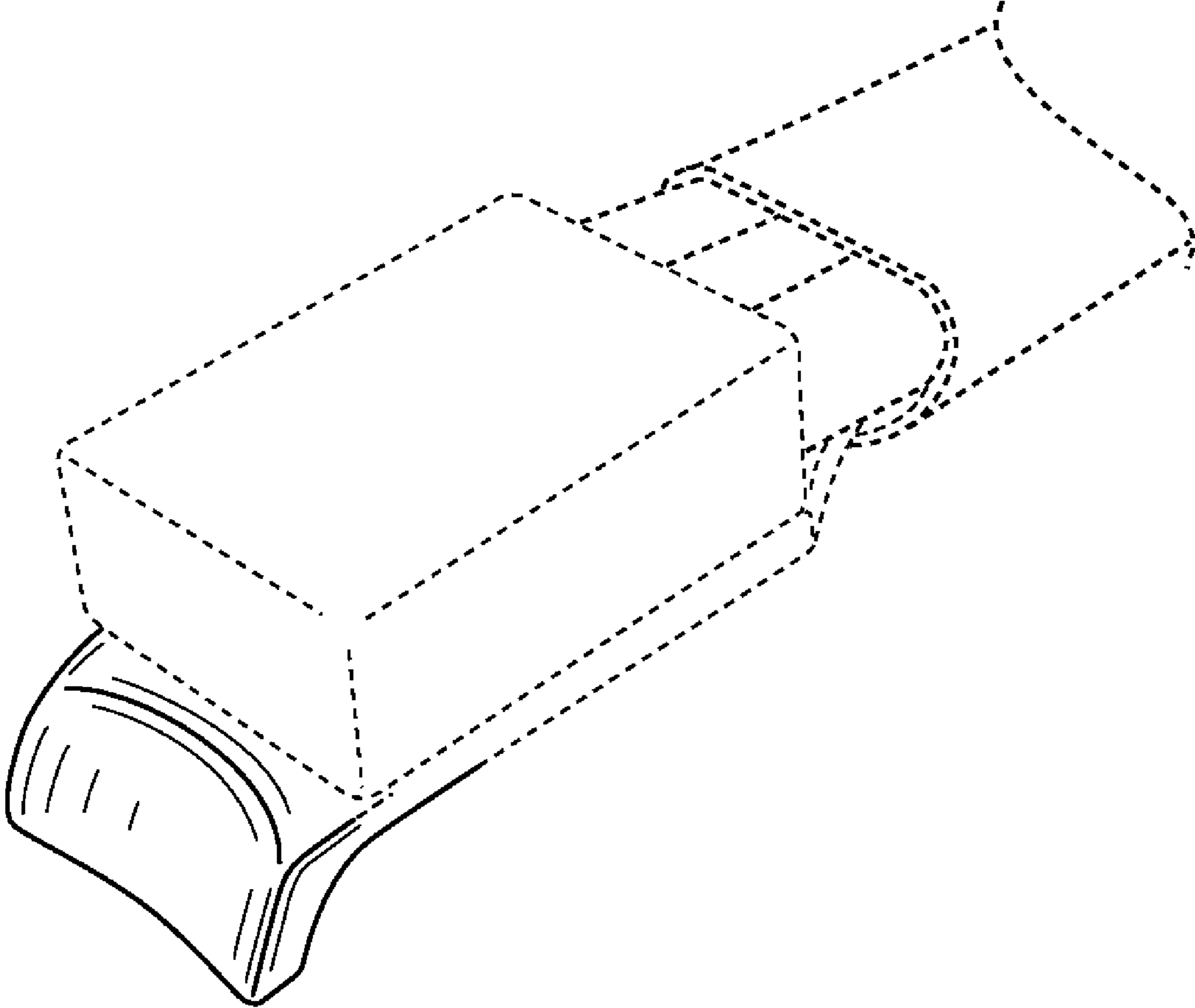

FIG. 14 is a ninth alternate bottom view of the design.  
FIG. 15 is a tenth alternate bottom view of the design.  
FIG. 16 is an eleventh alternate bottom view of the design.  
FIG. 17 is a twelfth alternate bottom view of the design.  
FIG. 18 is a thirteenth alternate bottom view of the design.  
FIG. 19 is a fourteenth alternate bottom view of the design.  
FIG. 20 is a fifteenth alternate bottom view of the design.  
FIG. 21 is a sixteenth alternate bottom view of the design.  
FIG. 22 is a seventeenth alternate bottom view of the design.  
FIG. 23 is an eighteenth alternate bottom view of the design.  
FIG. 24 is a nineteenth alternate bottom view of the design.  
FIG. 25 is a twentieth alternate bottom view of the design.  
FIG. 26 is a twenty-first alternate bottom view of the design.  
FIG. 27 is a twenty-second alternate bottom view of the design.  
FIG. 28 is a twenty-third alternate bottom view of the design.  
FIG. 29 is a twenty-fourth alternate bottom view of the design.  
FIG. 30 is a twenty-fifth alternate bottom view of the design.  
FIG. 31 is a perspective view of a second embodiment for a portion of a nerve root retractor with sensor.  
FIG. 32 is a right side view thereof;  
FIG. 33 is a left side view thereof;  
FIG. 34 is a top view thereof;  
FIG. 35 is a front view thereof; and  
FIG. 36 is a first alternate bottom view of the design.  
FIG. 37 is a second alternate bottom view of the design.  
FIG. 38 is a third alternate bottom view of the design.  
FIG. 39 is a fourth alternate bottom view of the design.  
FIG. 40 is a fifth alternate bottom view of the design.

FIG. 41 is a sixth alternate bottom view of the design.  
FIG. 42 is a seventh alternate bottom view of the design.  
FIG. 43 is an eighth alternate bottom view of the design.  
FIG. 44 is a ninth alternate bottom view of the design.  
FIG. 45 is a tenth alternate bottom view of the design.  
FIG. 46 is an eleventh alternate bottom view of the design.  
FIG. 47 is a twelfth alternate bottom view of the design.  
FIG. 48 is a thirteenth alternate bottom view of the design.  
FIG. 49 is a fourteenth alternate bottom view of the design.  
FIG. 50 is a fifteenth alternate bottom view of the design.  
FIG. 51 is a sixteenth alternate bottom view of the design.  
FIG. 52 is a seventeenth alternate bottom view of the design.  
FIG. 53 is an eighteenth alternate bottom view of the design.  
FIG. 54 is a nineteenth alternate bottom view of the design.  
FIG. 55 is a twentieth alternate bottom view of the design.  
FIG. 56 is a twenty-first alternate bottom view of the design.  
FIG. 57 is a twenty-second alternate bottom view of the design.  
FIG. 58 is a twenty-third alternate bottom view of the design.  
FIG. 59 is a twenty-fourth alternate bottom view of the design; and,  
FIG. 60 is a twenty-fifth alternate bottom view of the design.  
Other views of FIGS. 7–30 (alternate bottom views) are the same as in FIGS. 1–5.  
Other views of FIGS. 37–60 (alternate bottom views) are the same as in FIGS. 31–35.  
The broken-line features in the figures are for illustrative purposes only and form no part of the claimed design.

**1 Claim, 22 Drawing Sheets**



**FIG. 1**

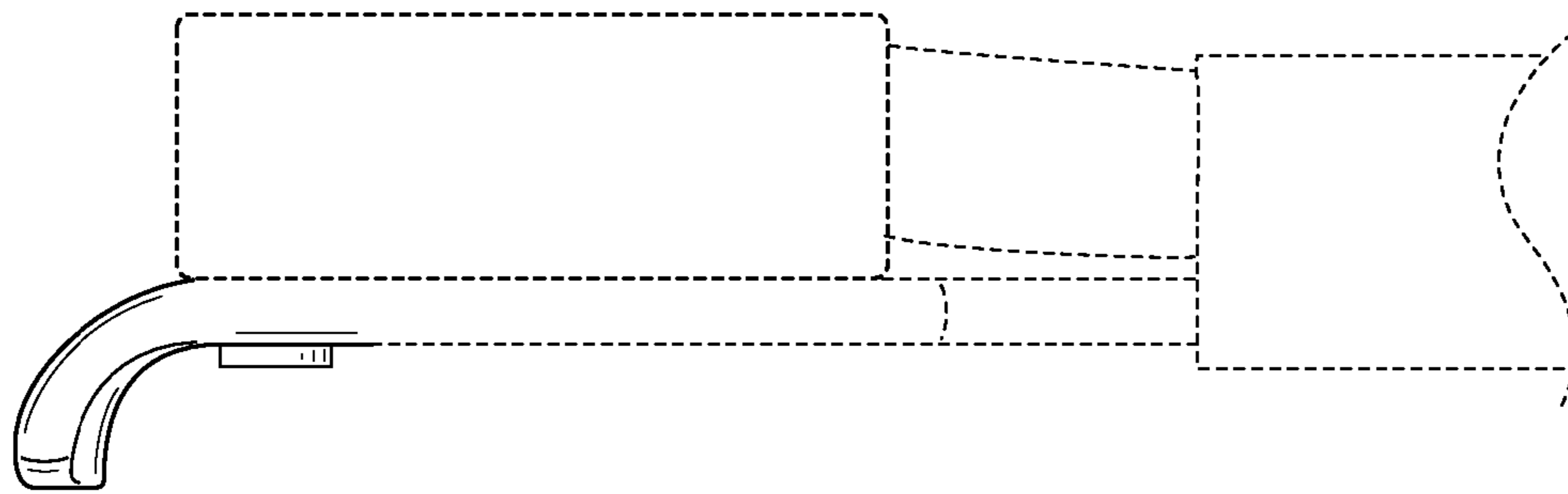

FIG. 2

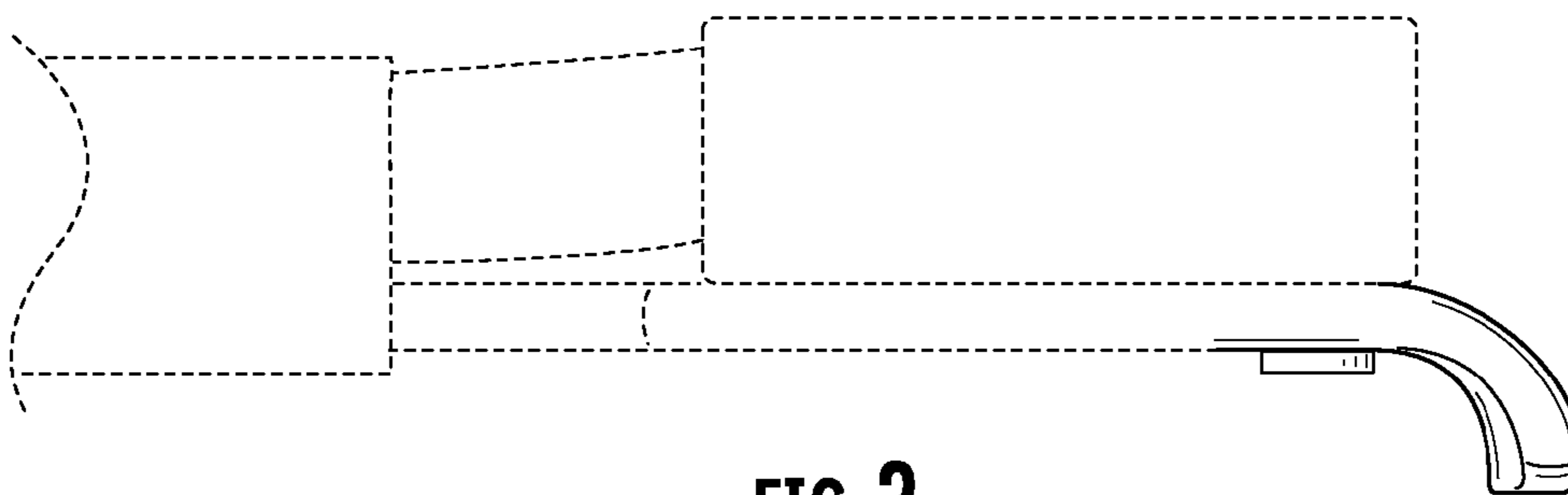

FIG. 3

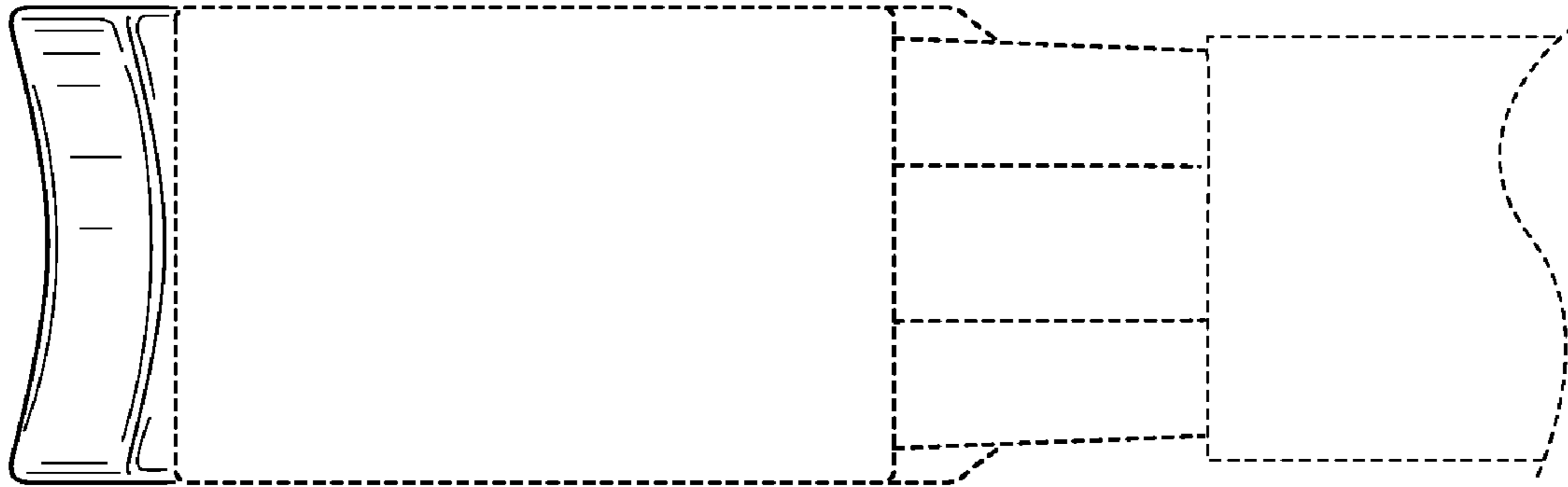

FIG. 4

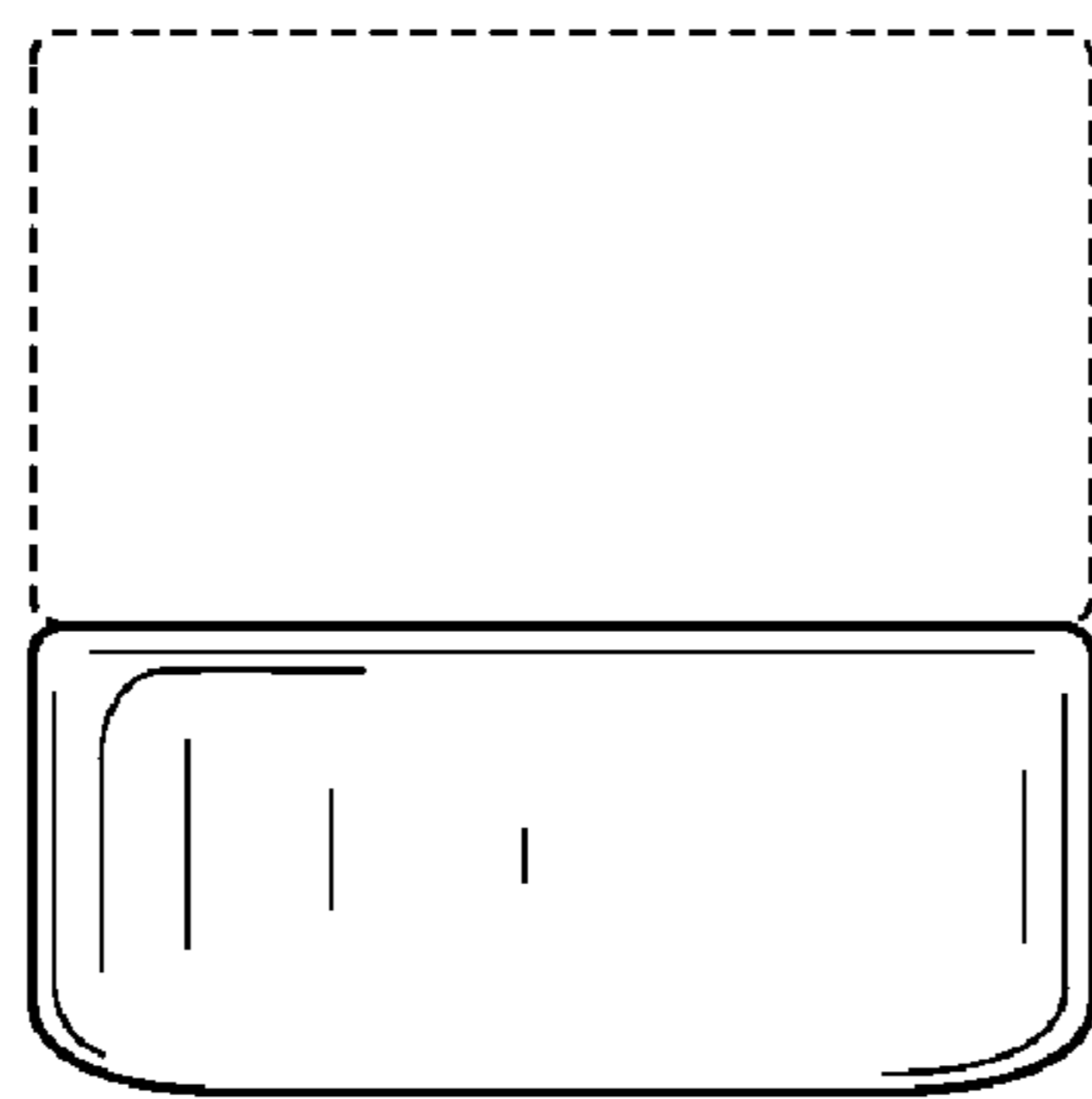

FIG. 5

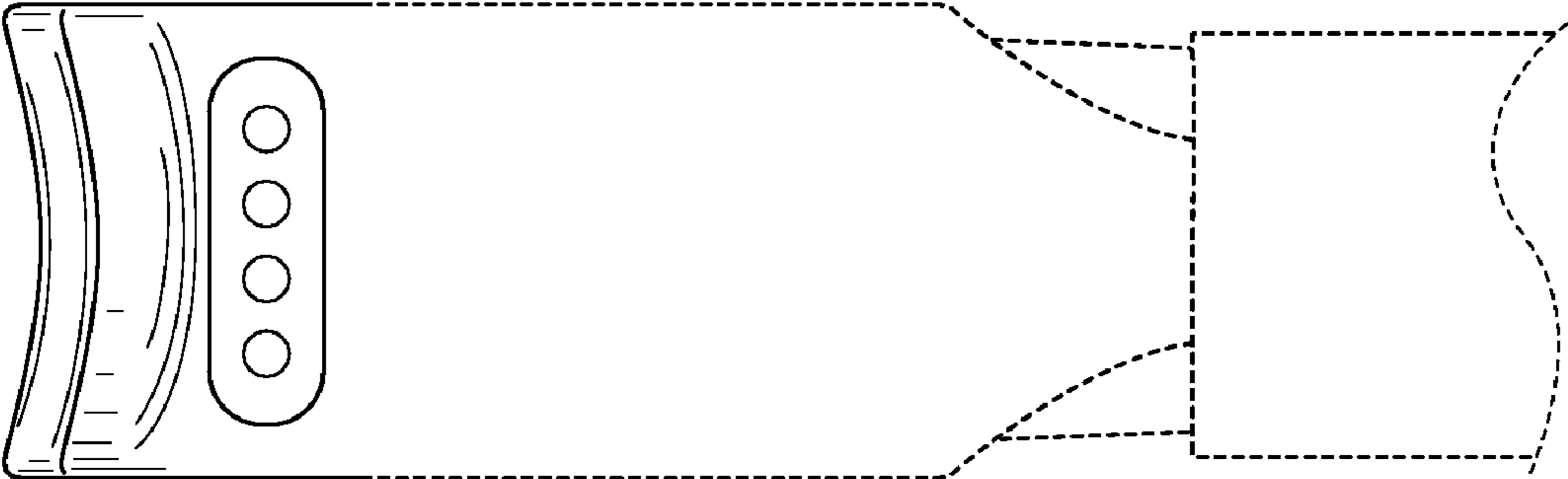

FIG. 6

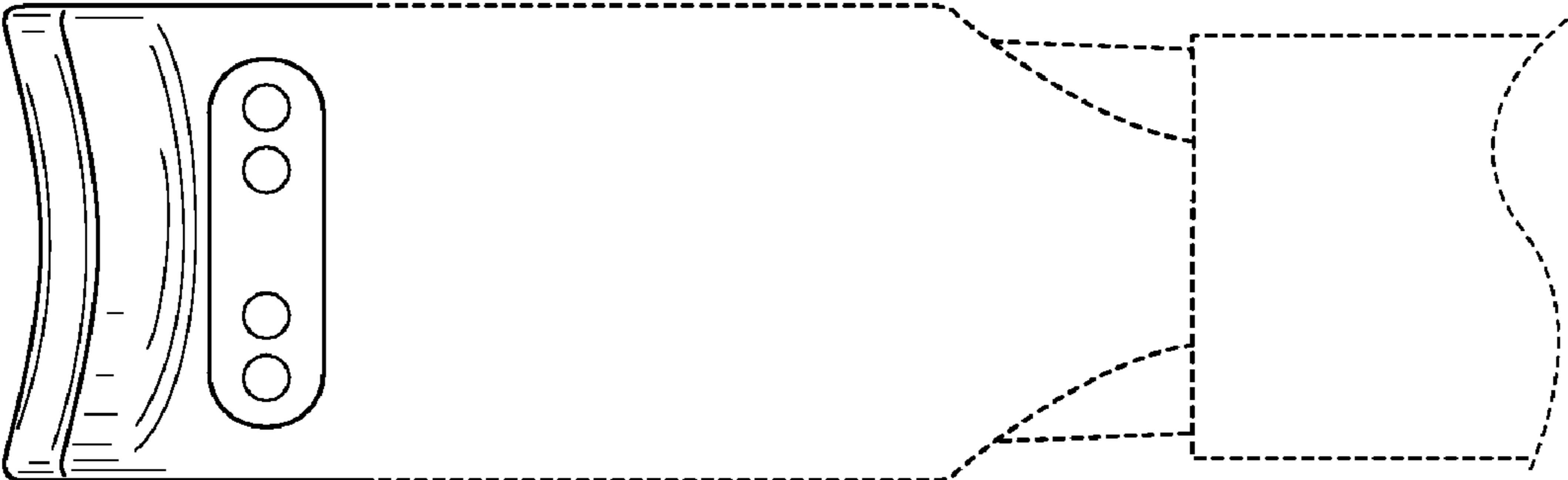

FIG. 7

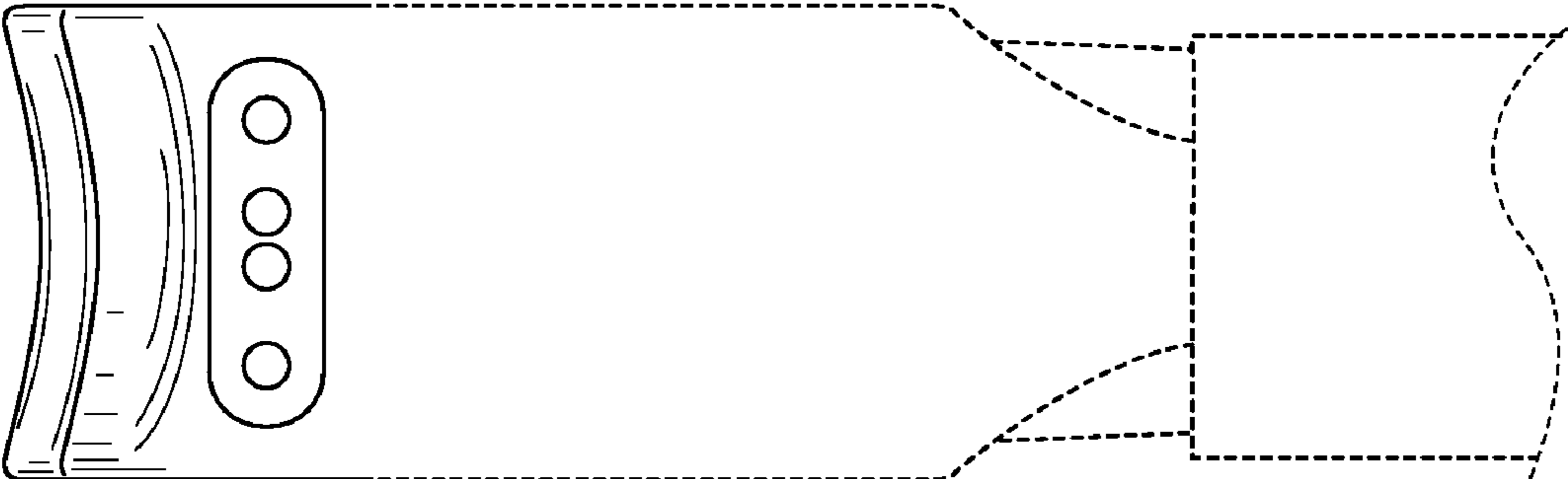

FIG. 8

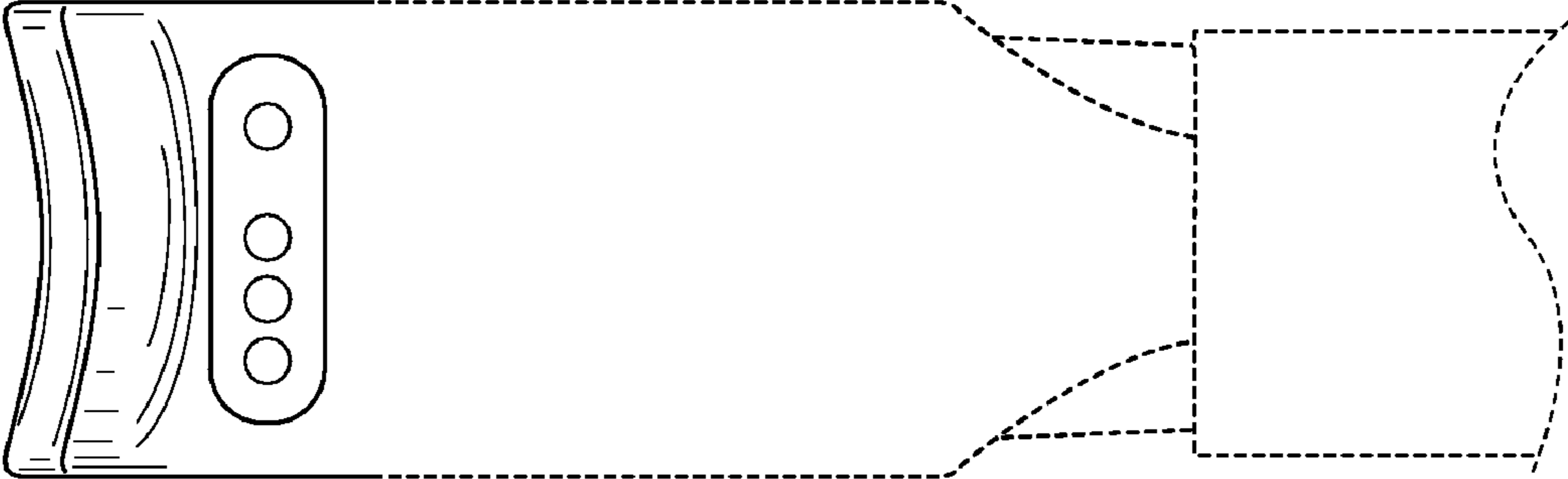

FIG. 9

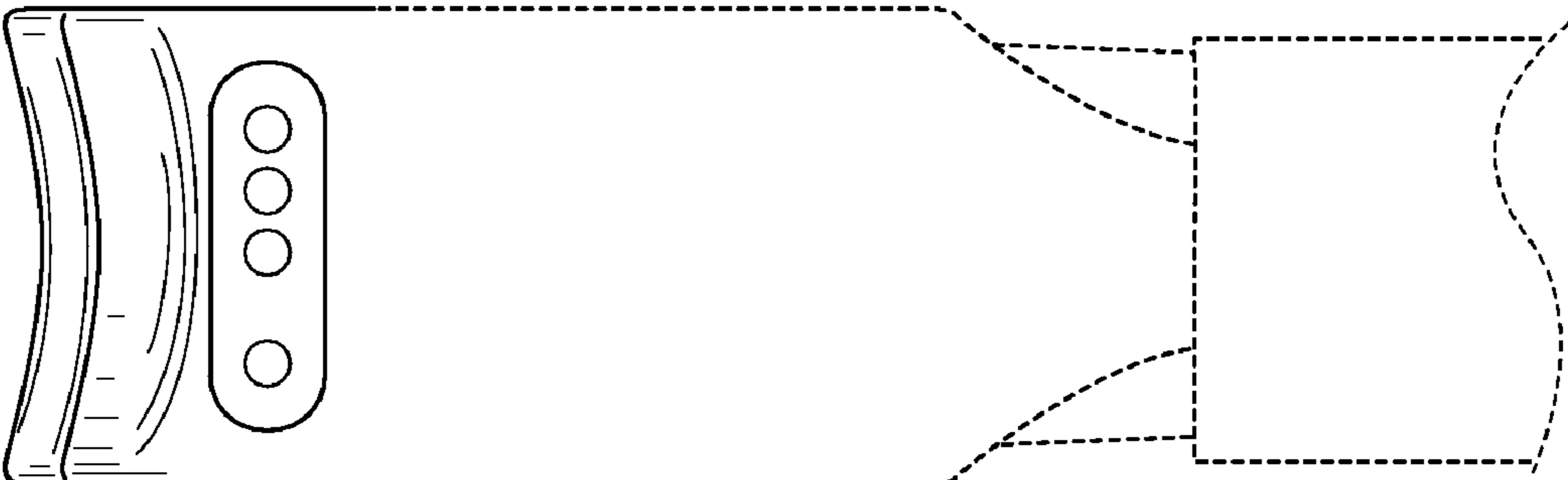

FIG. 10

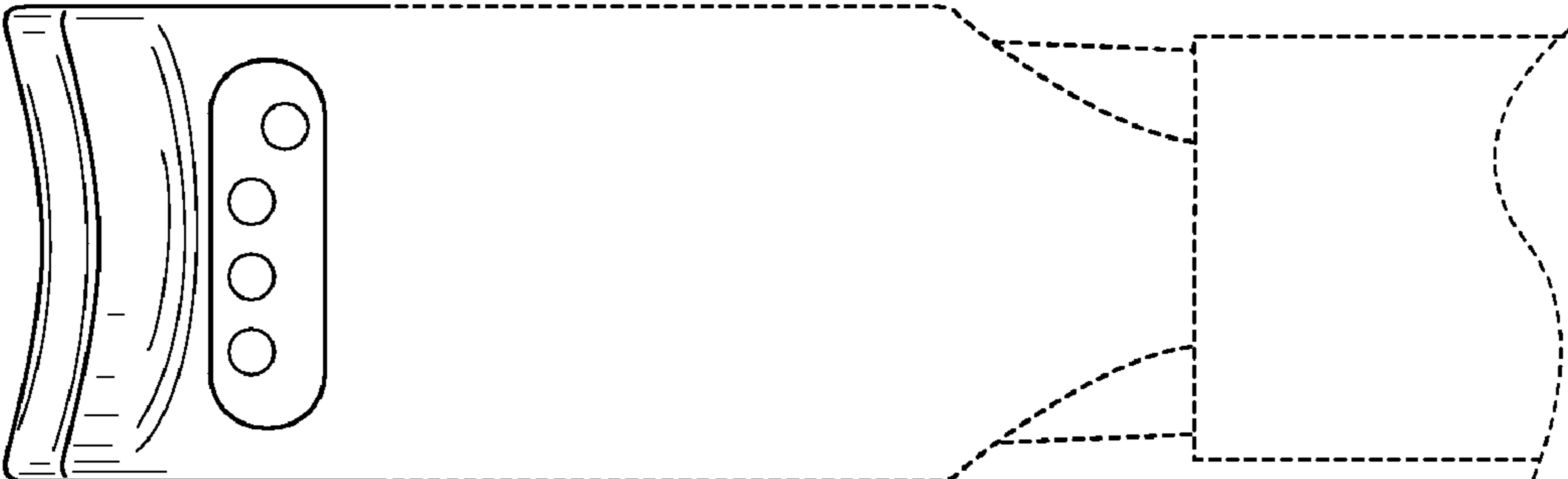

FIG. 11

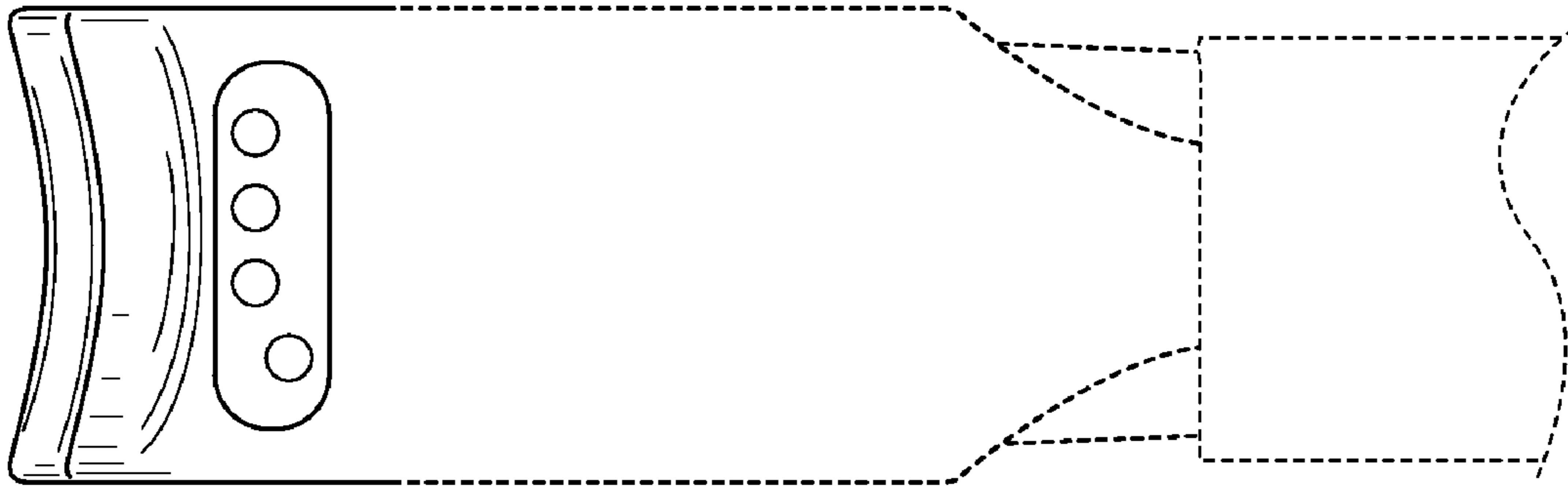

FIG. 12

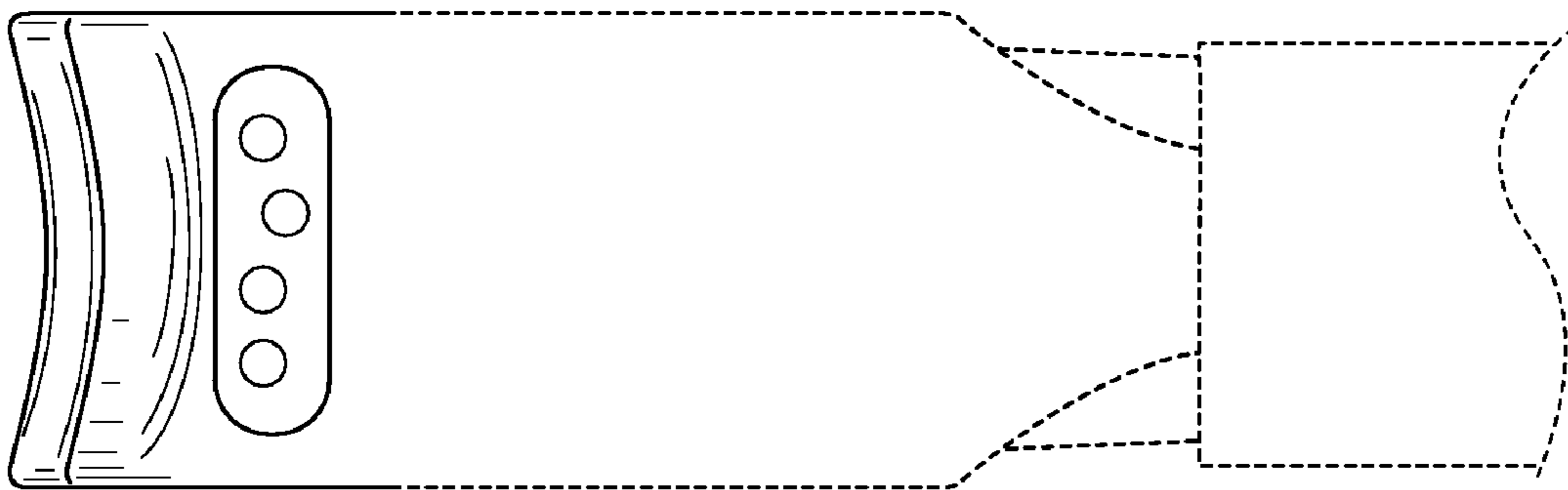

FIG. 13

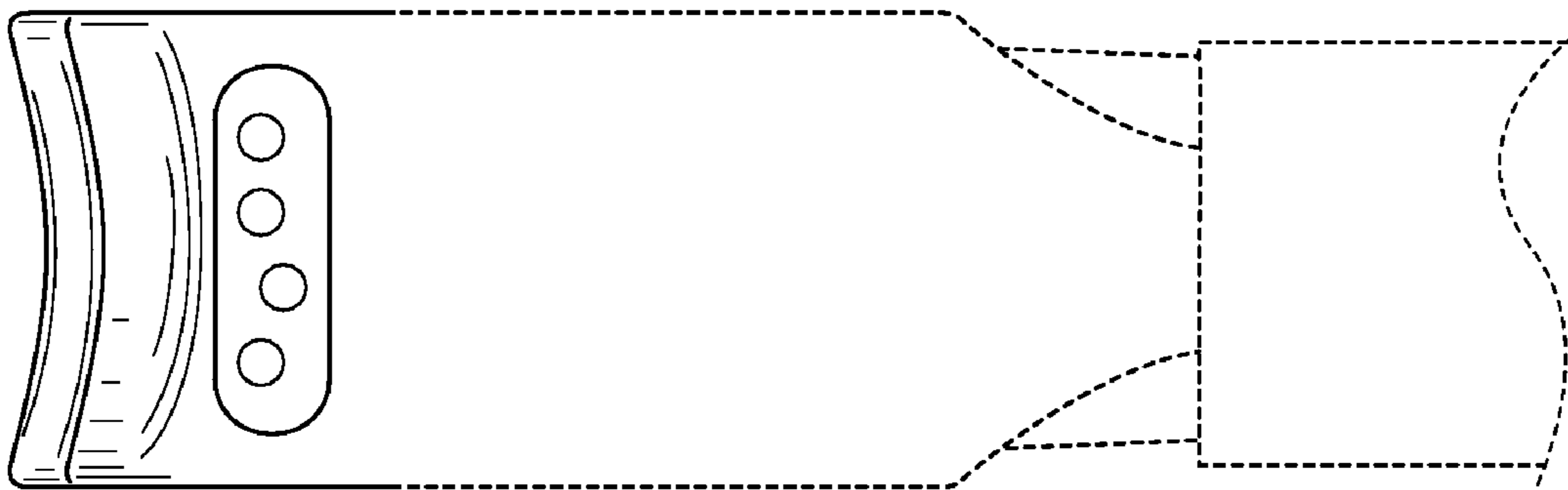

FIG. 14



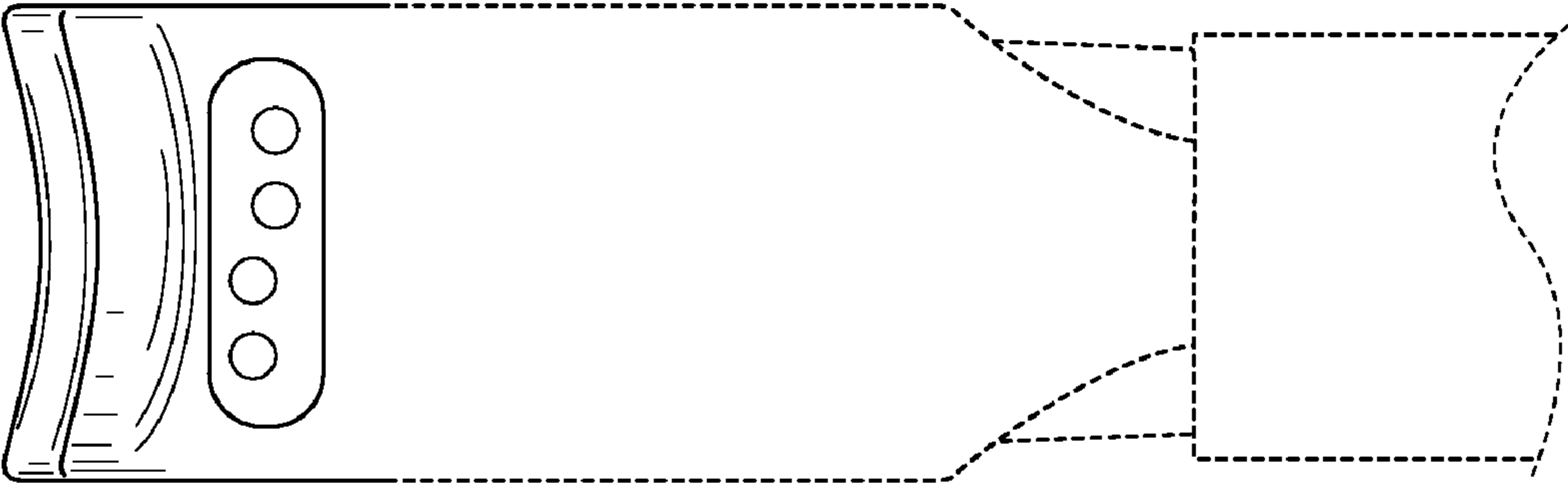

FIG. 15

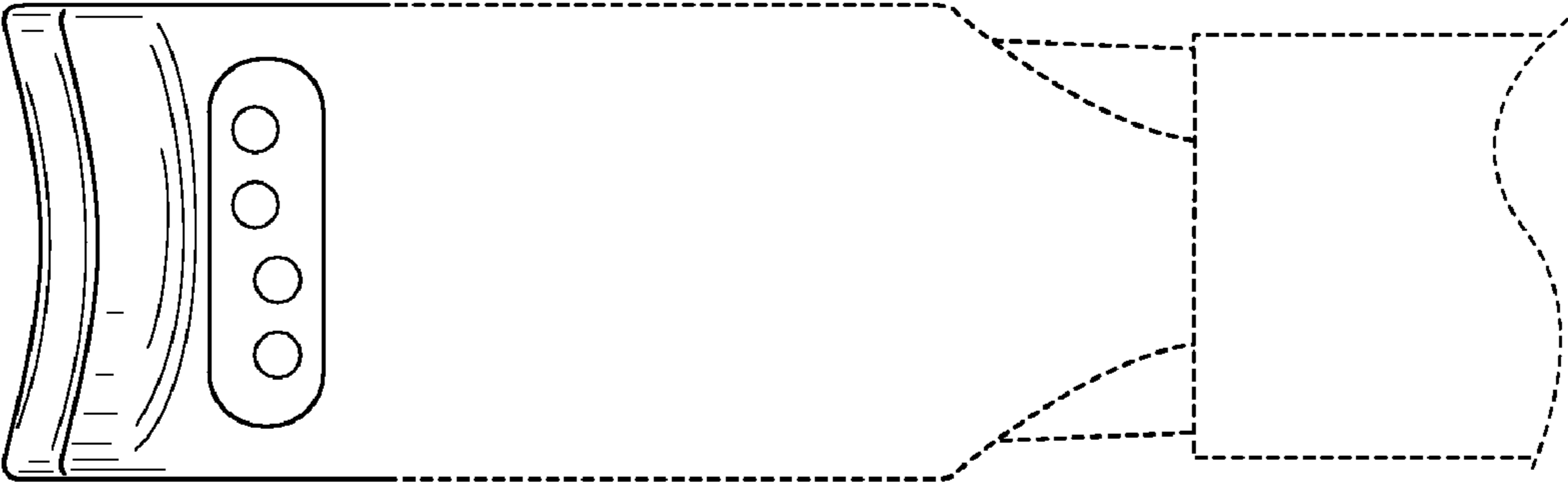

FIG. 16

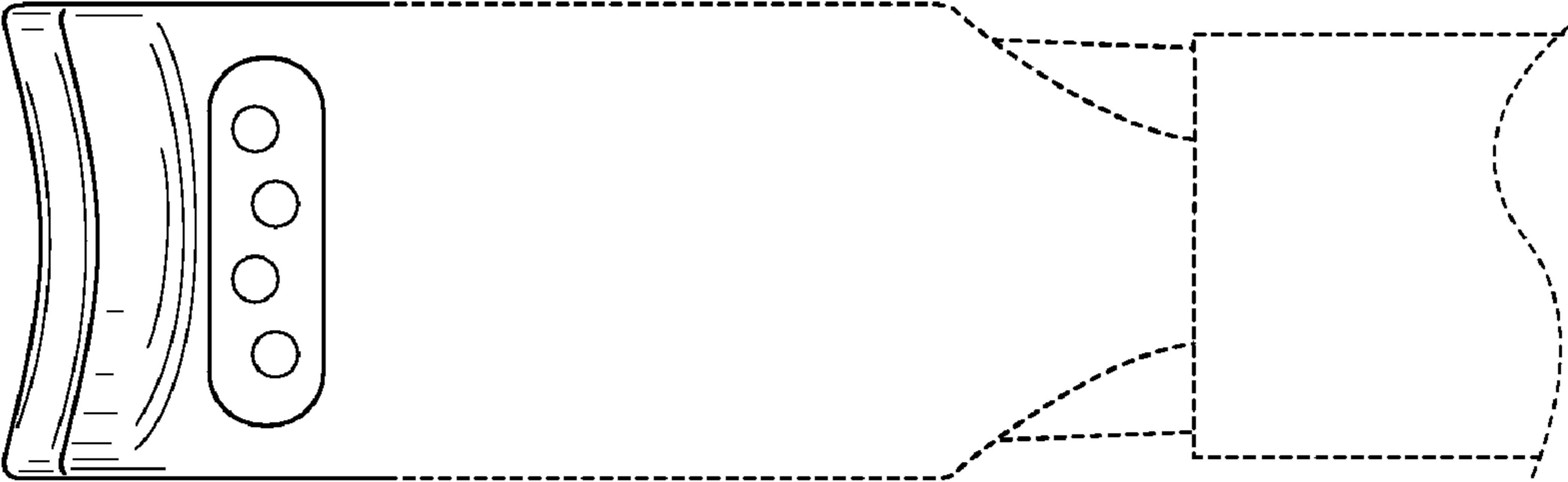
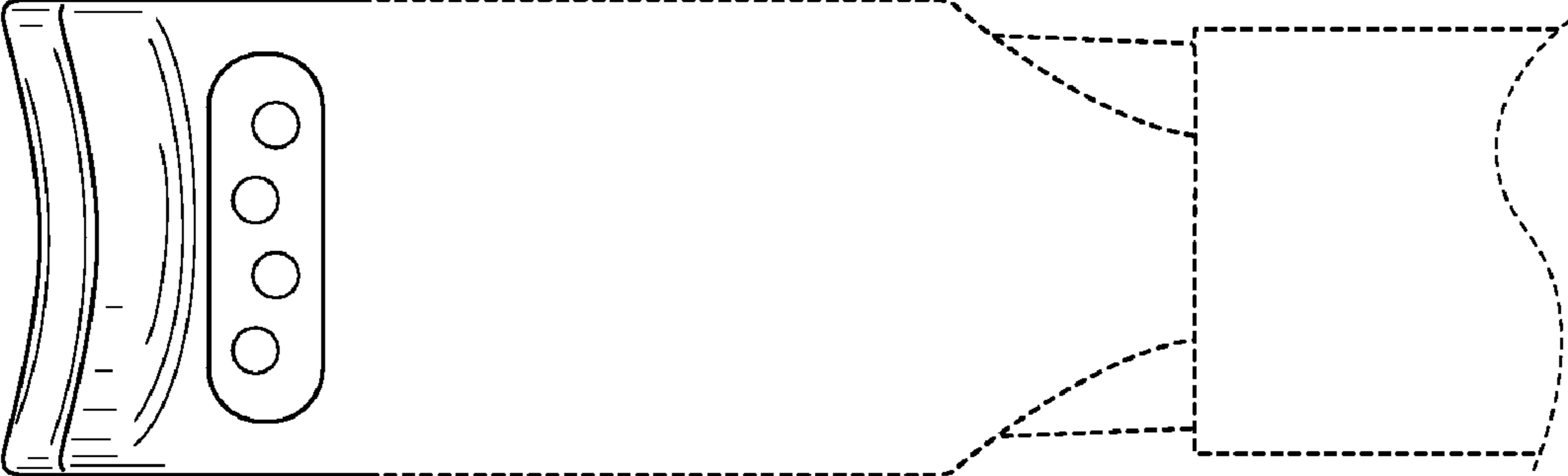
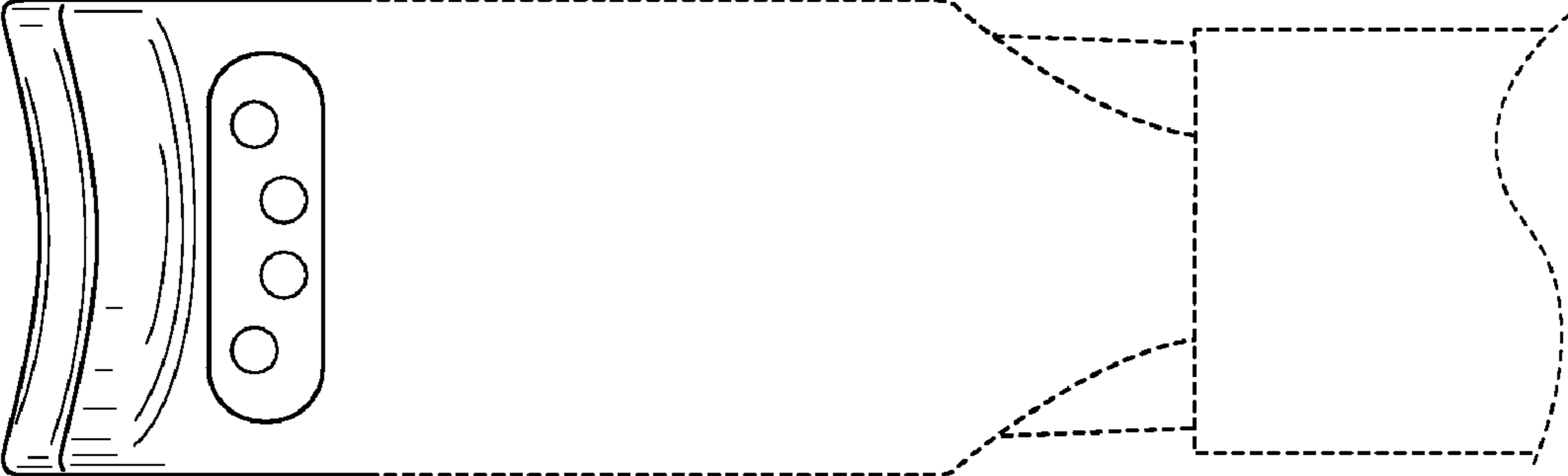

FIG. 17



**FIG. 18**



**FIG. 19**

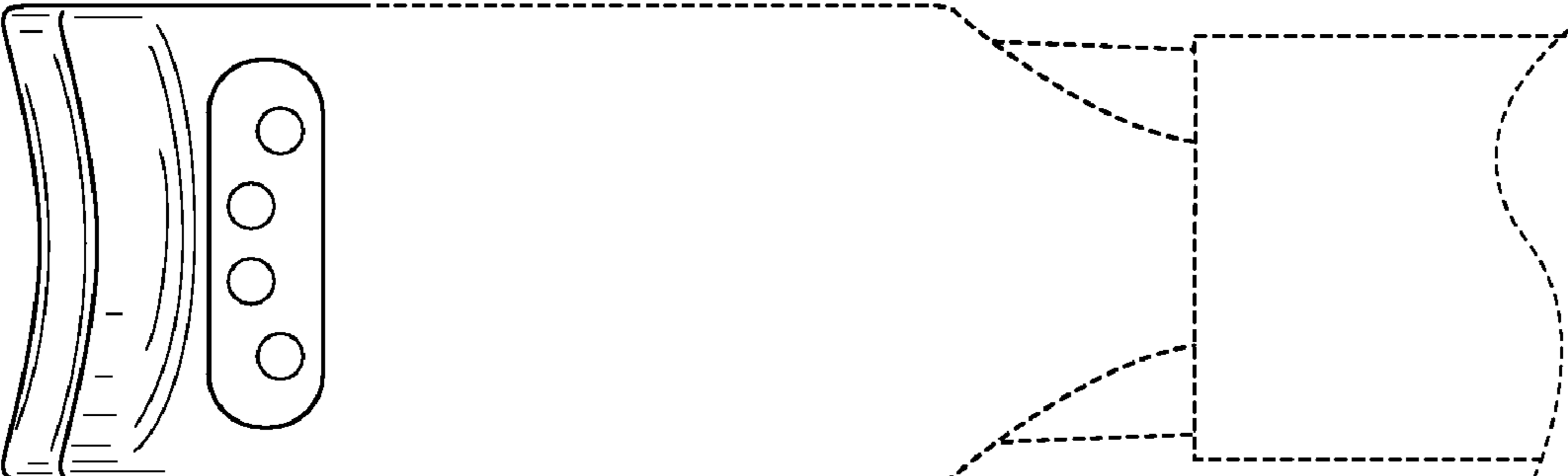

**FIG. 20**

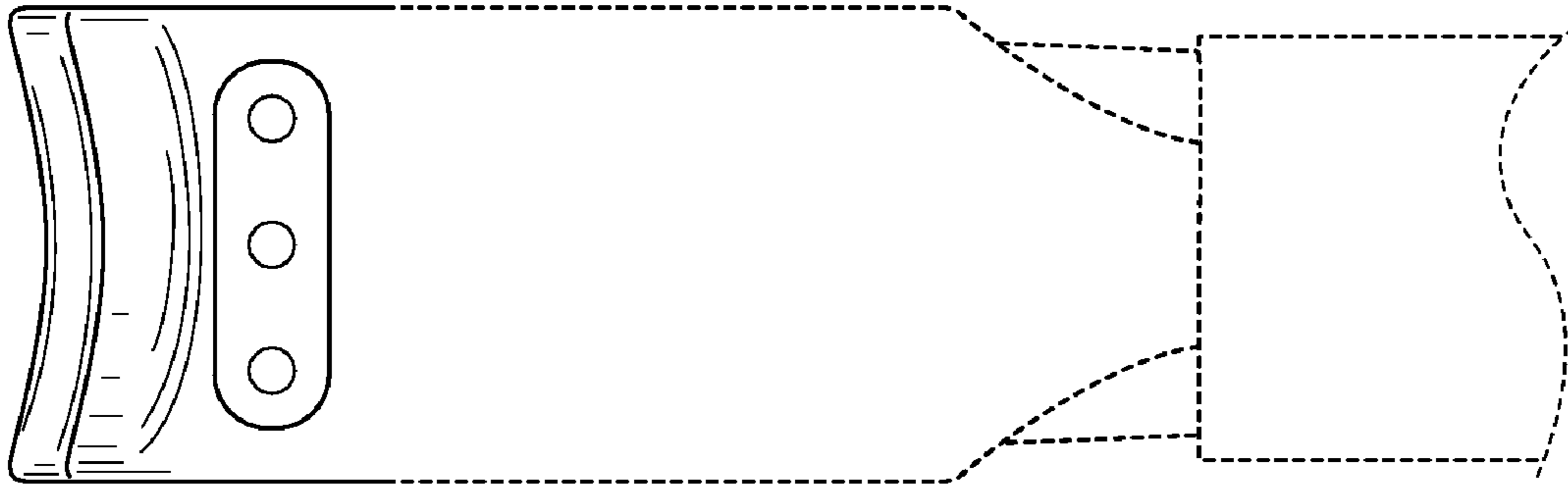

FIG. 21

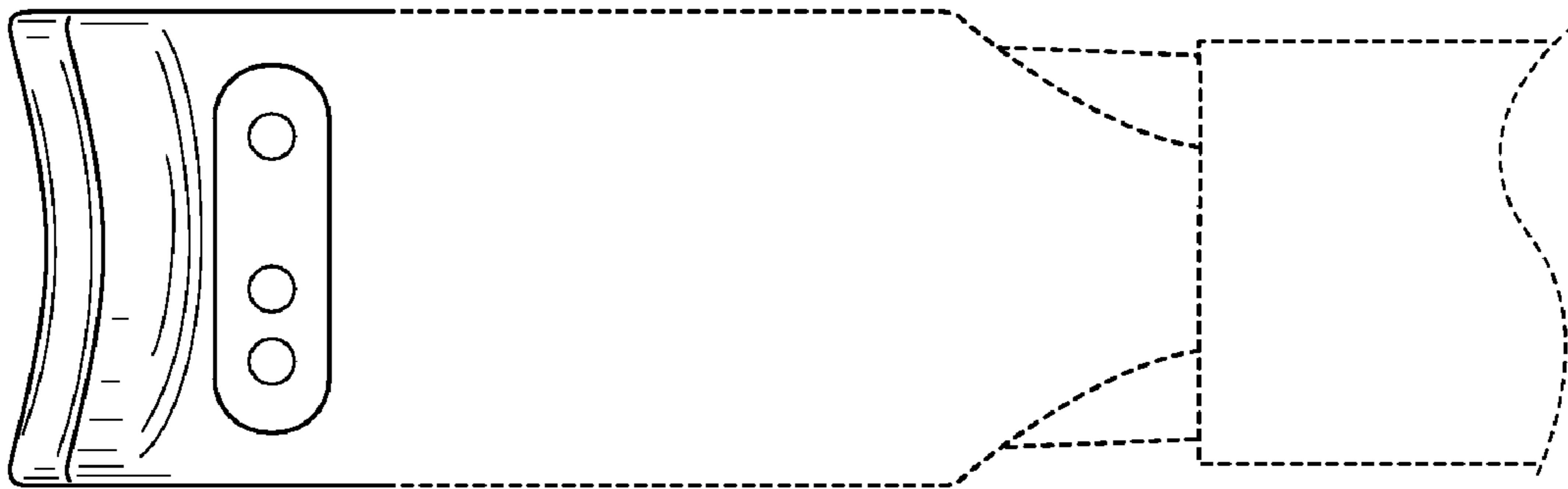

FIG. 22

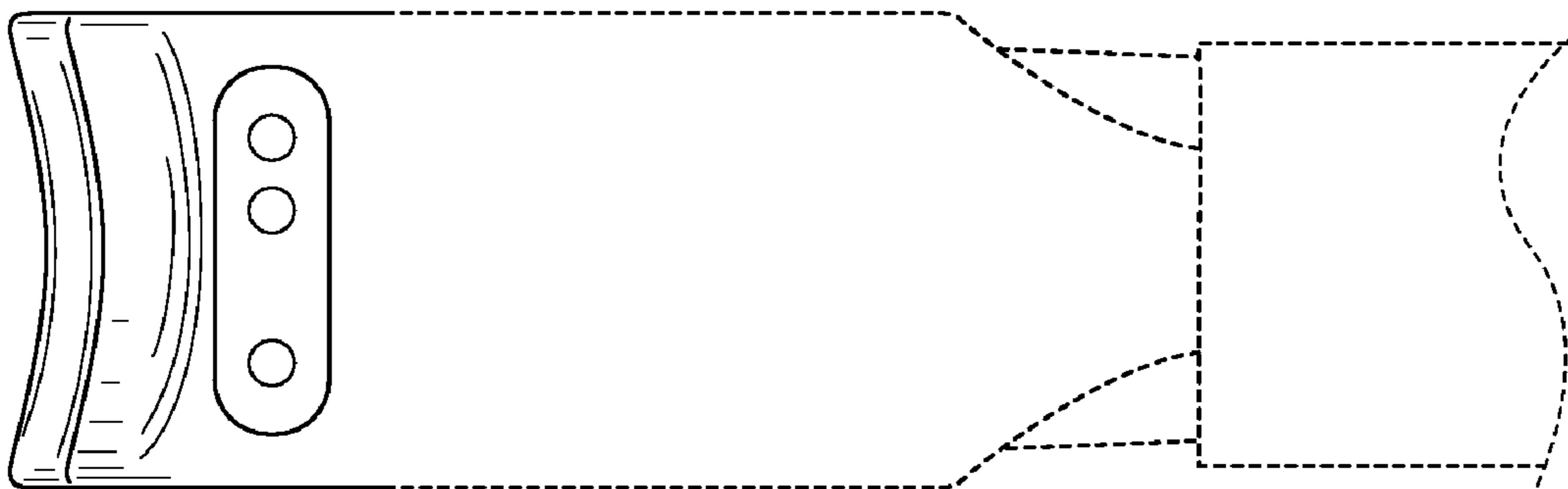

FIG. 23

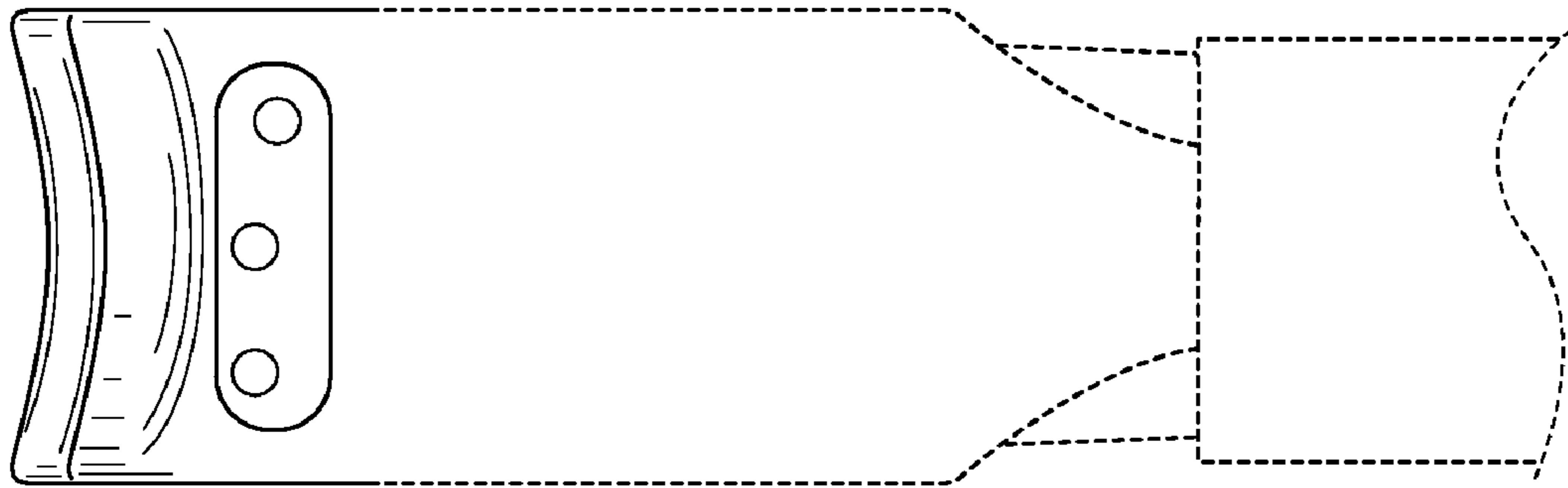

FIG. 24

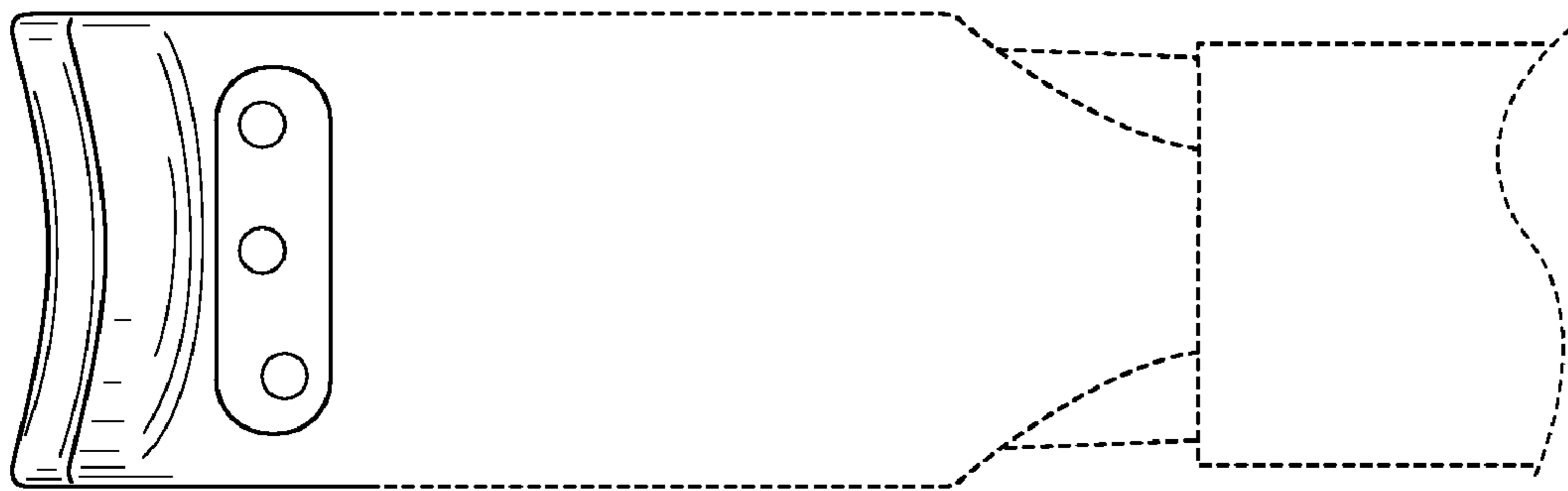

FIG. 25

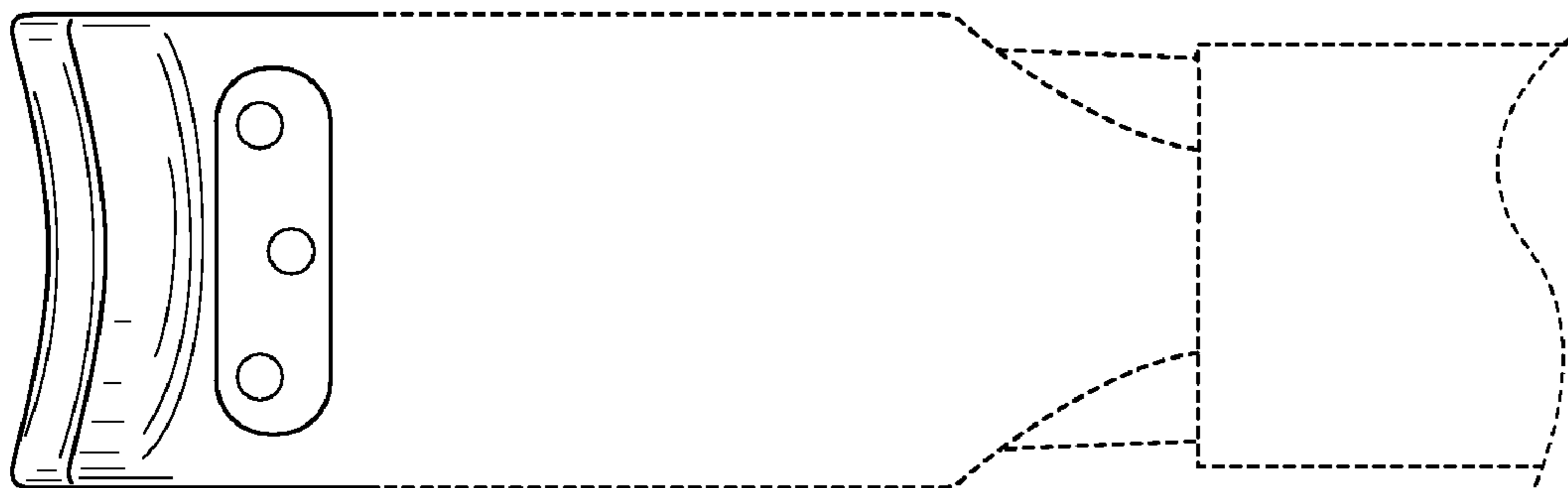

FIG. 26

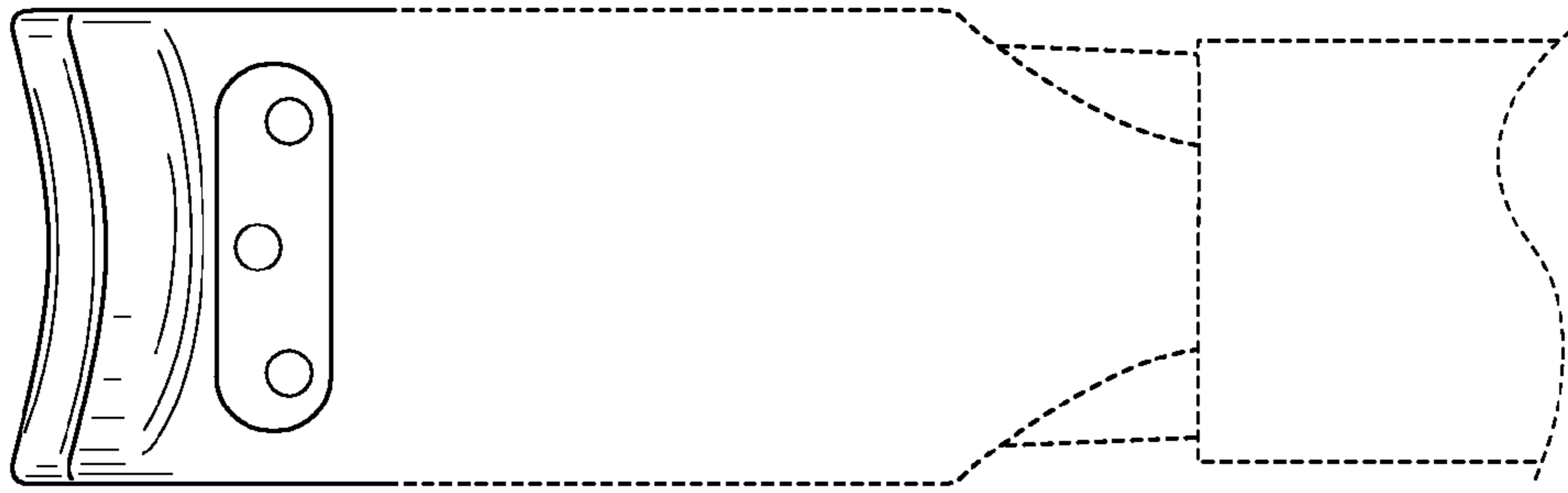

FIG. 27

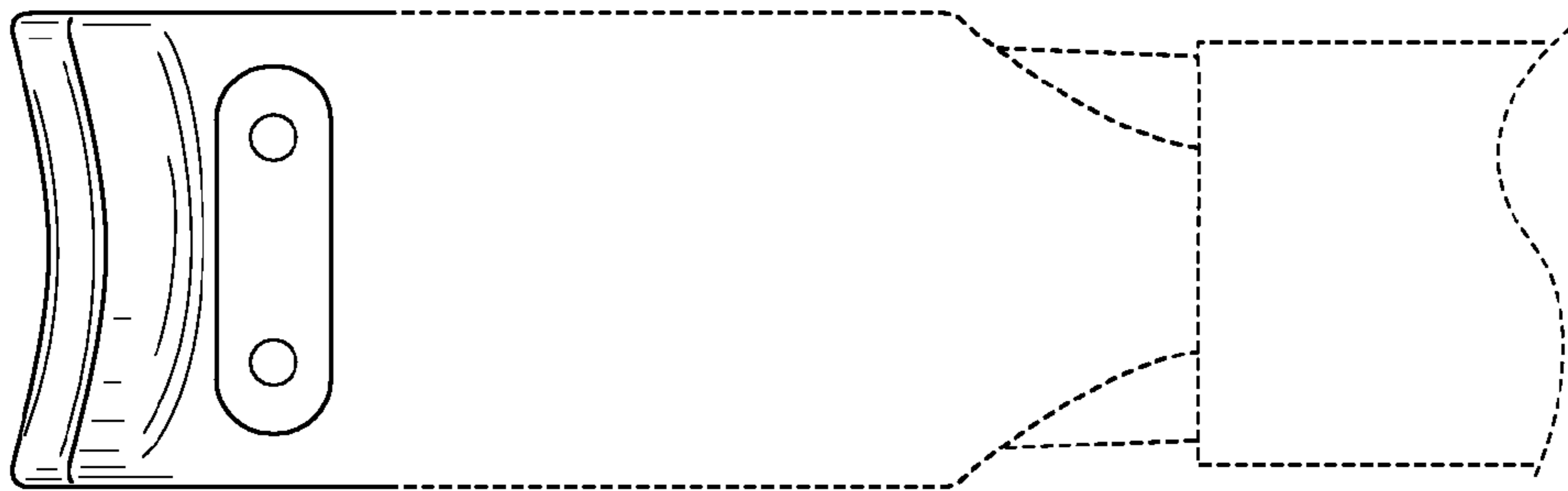

FIG. 28

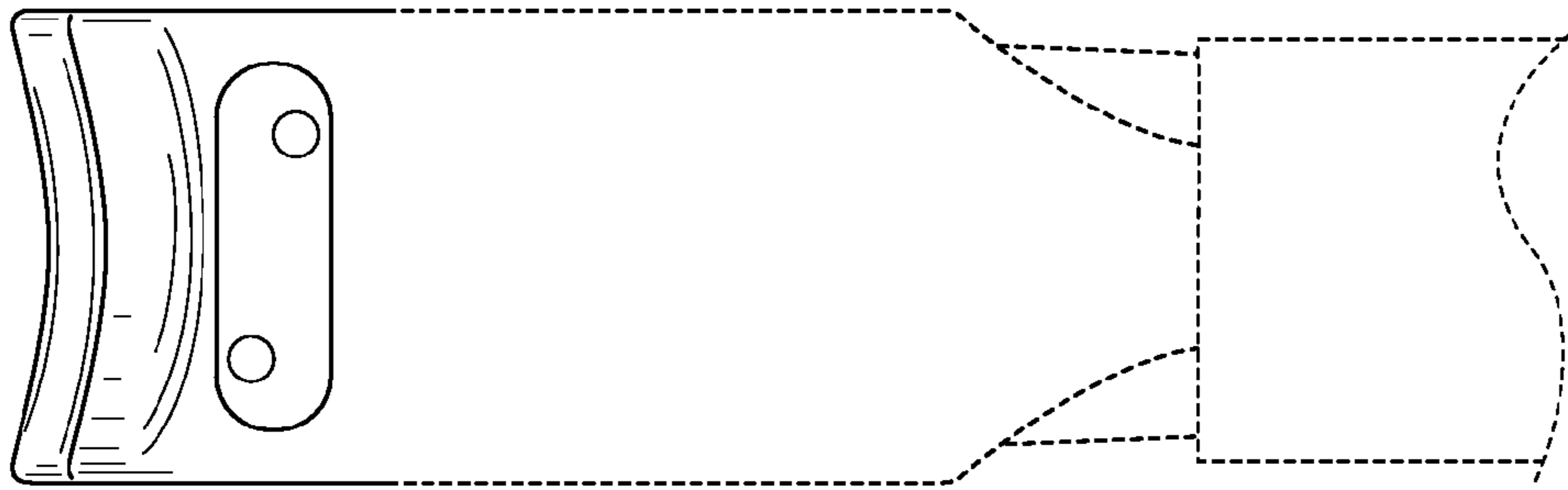

FIG. 29

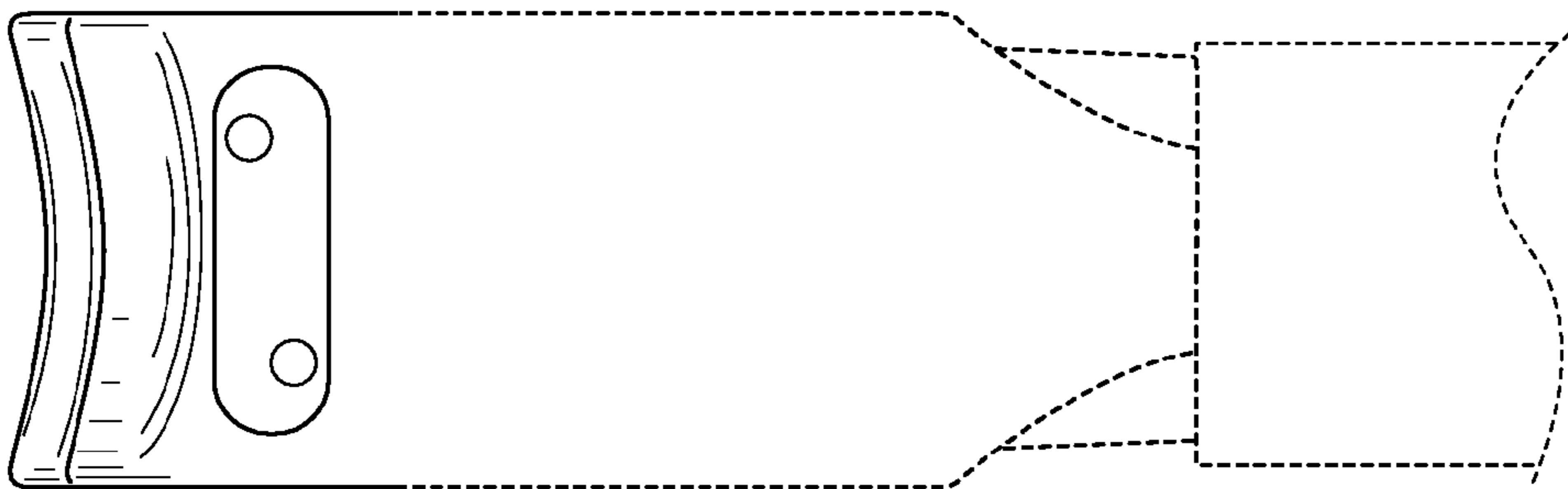
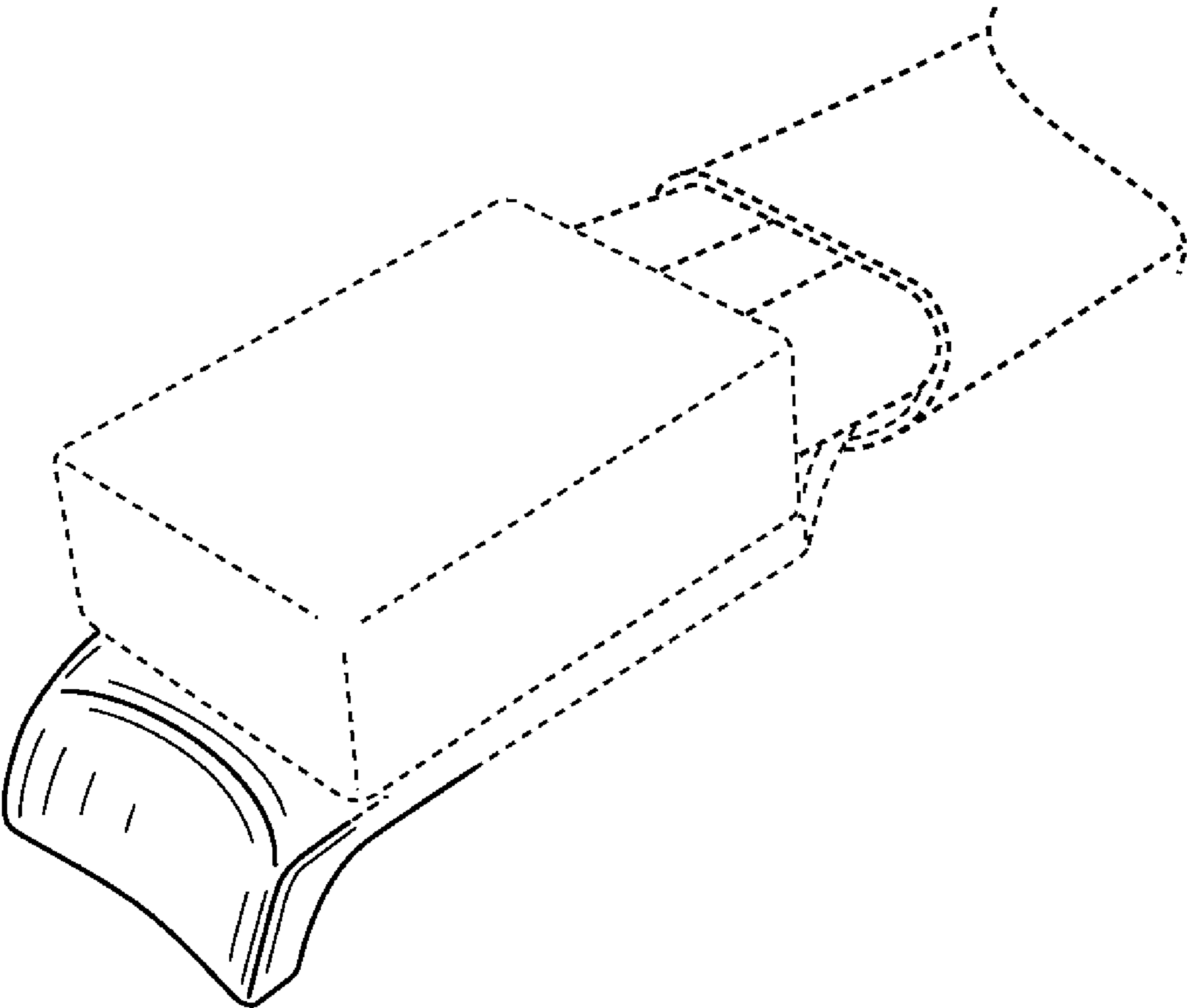

FIG. 30



**FIG. 31**

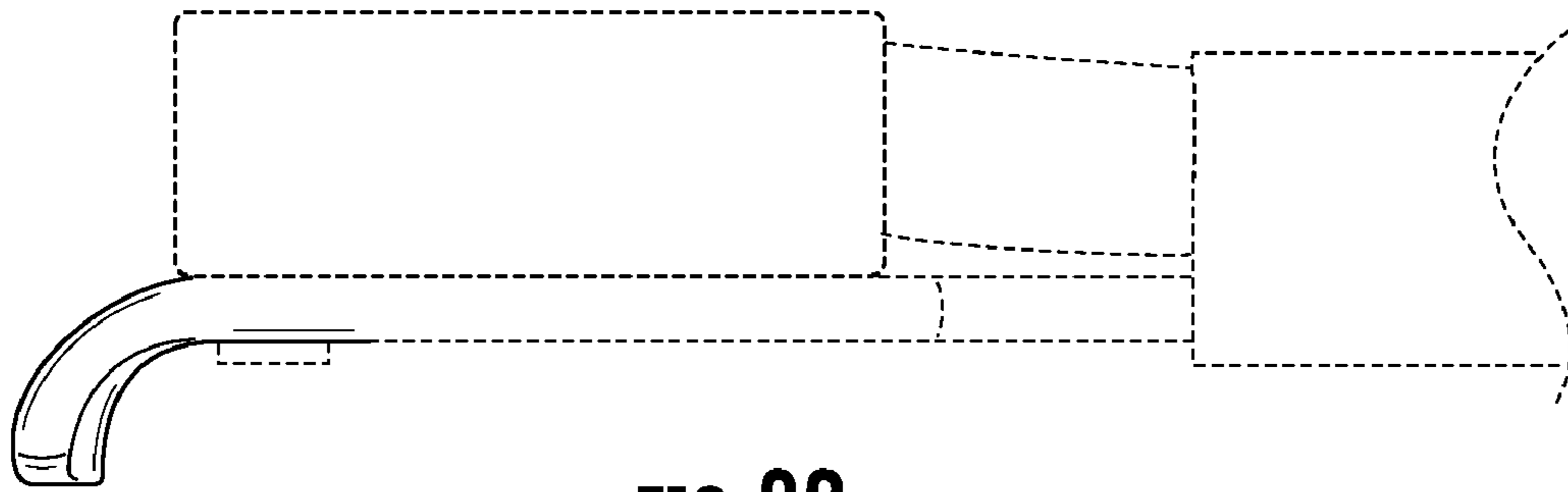

FIG. 32

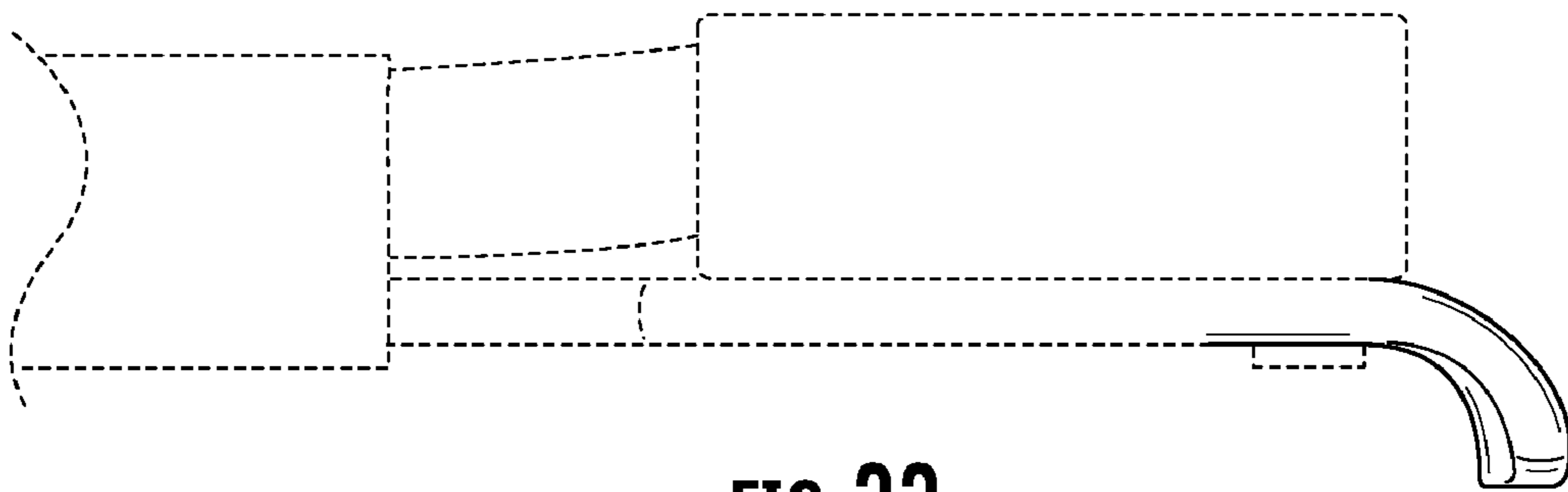

FIG. 33

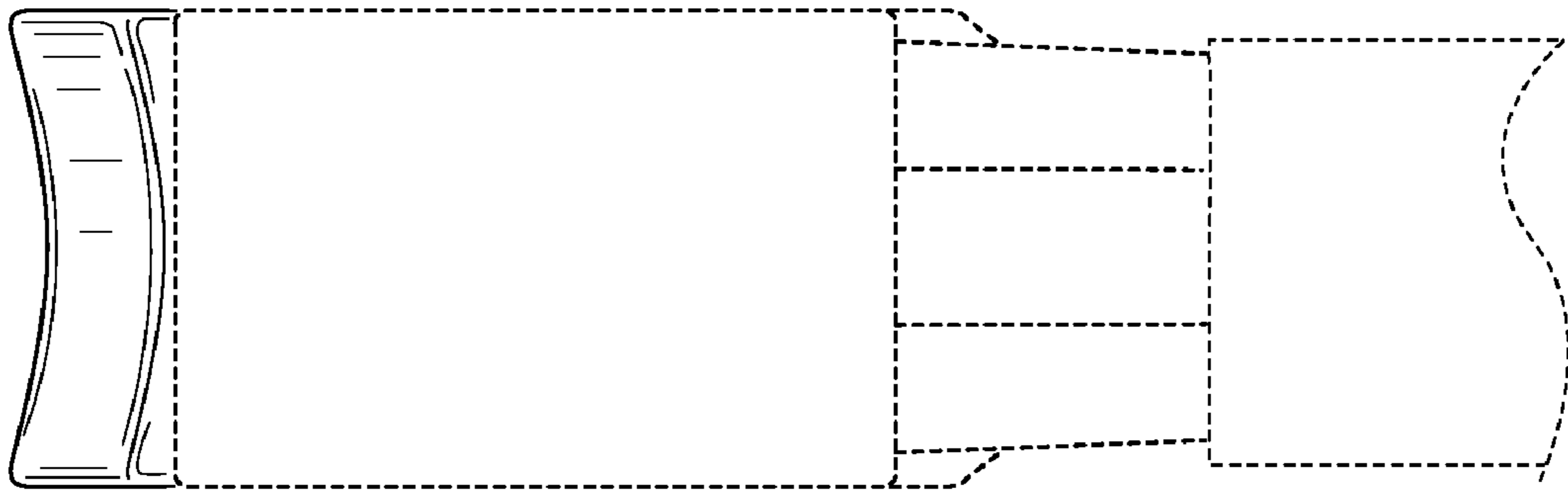

FIG. 34

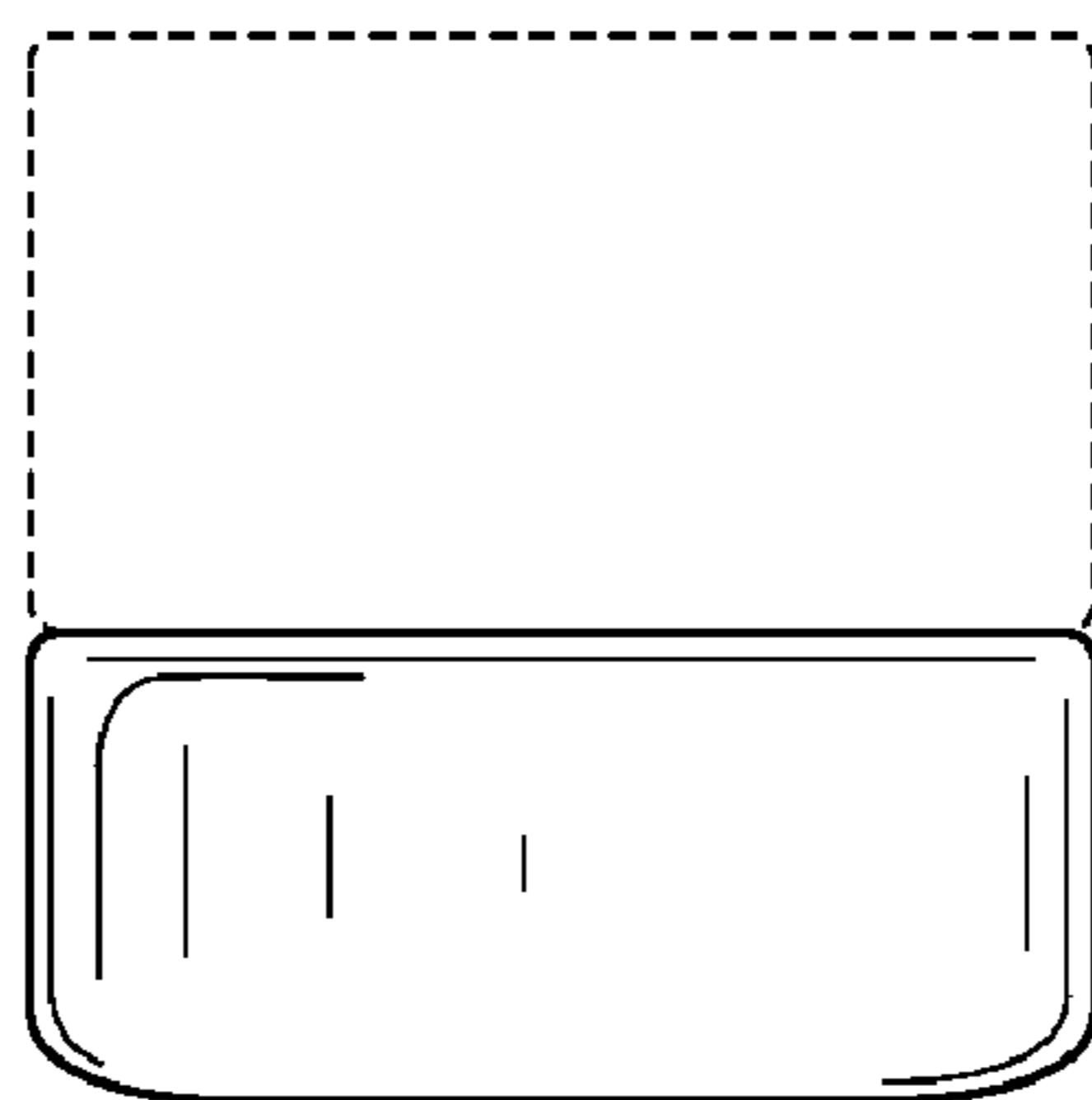
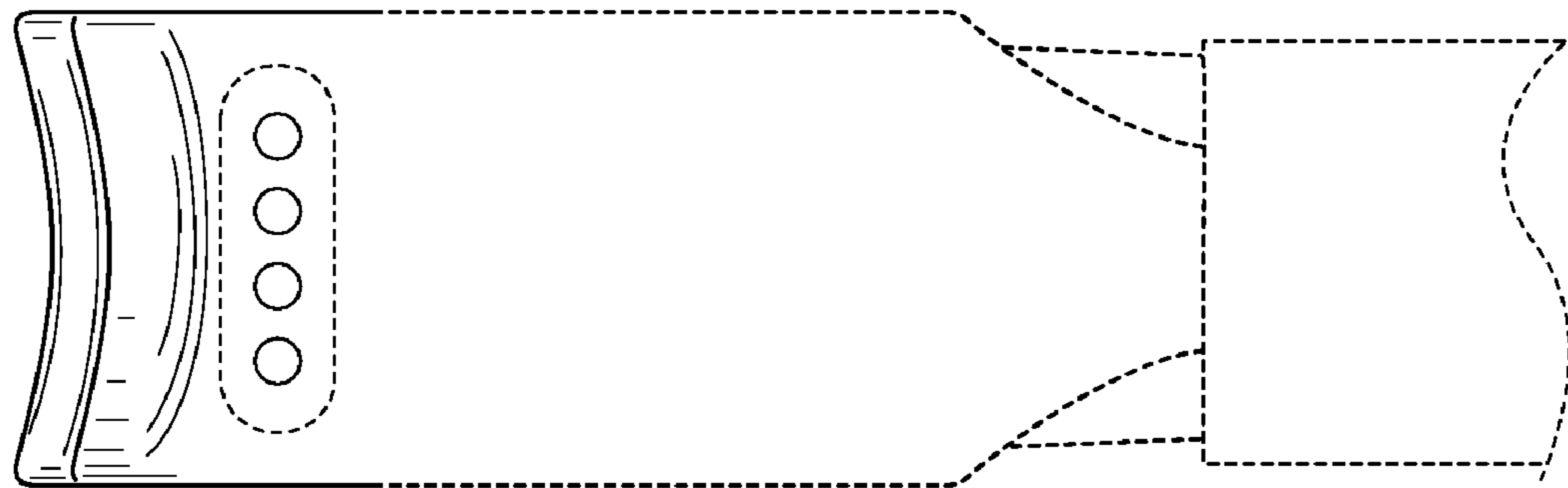
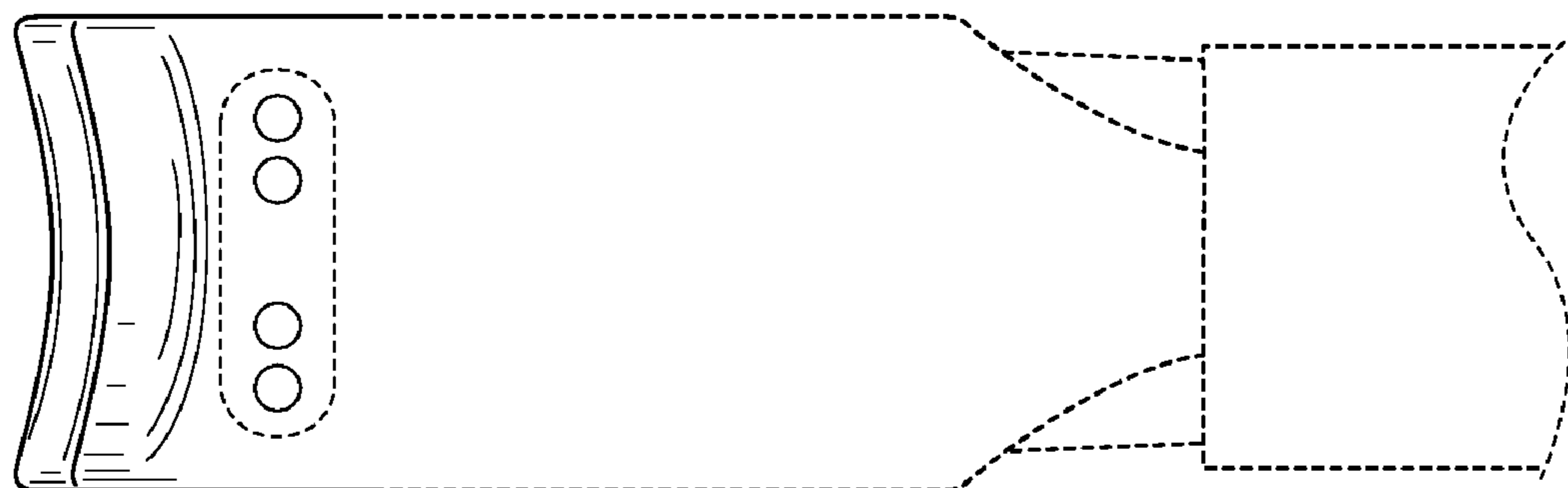

FIG. 35

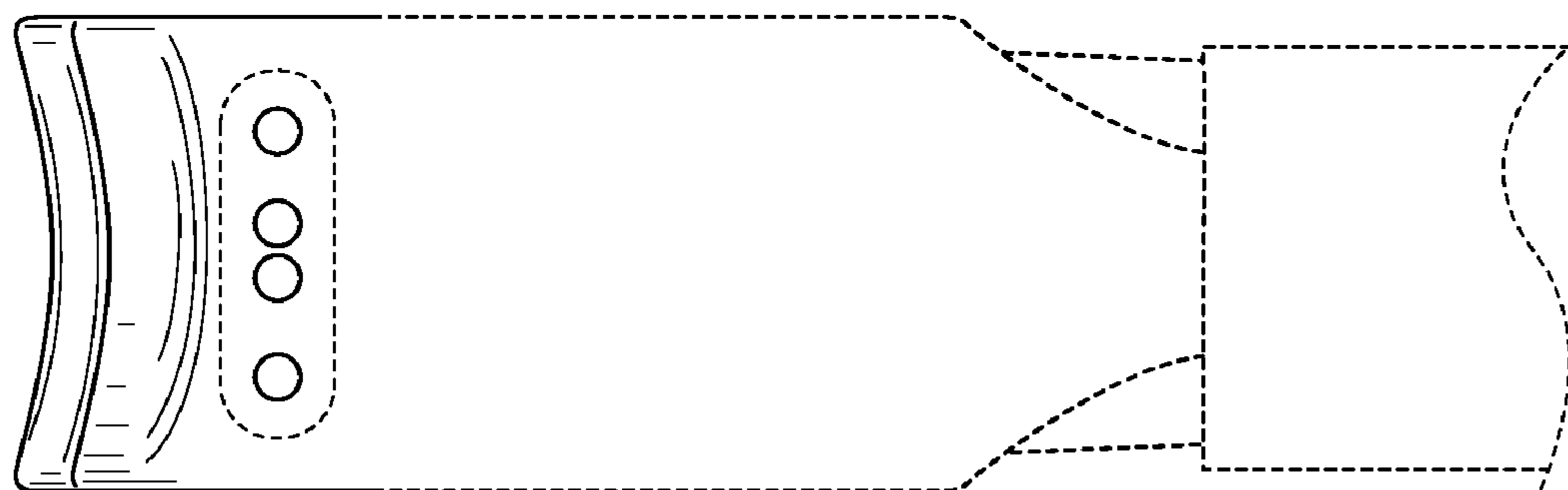



**FIG. 36**



**FIG. 37**



**FIG. 38**

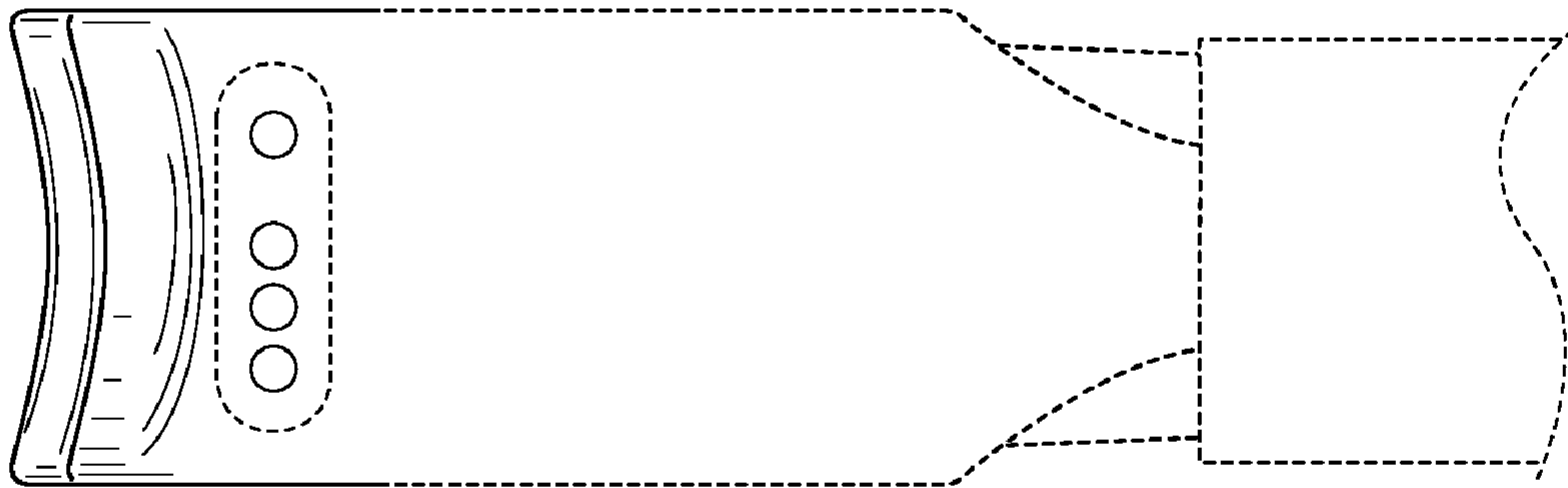

FIG. 39

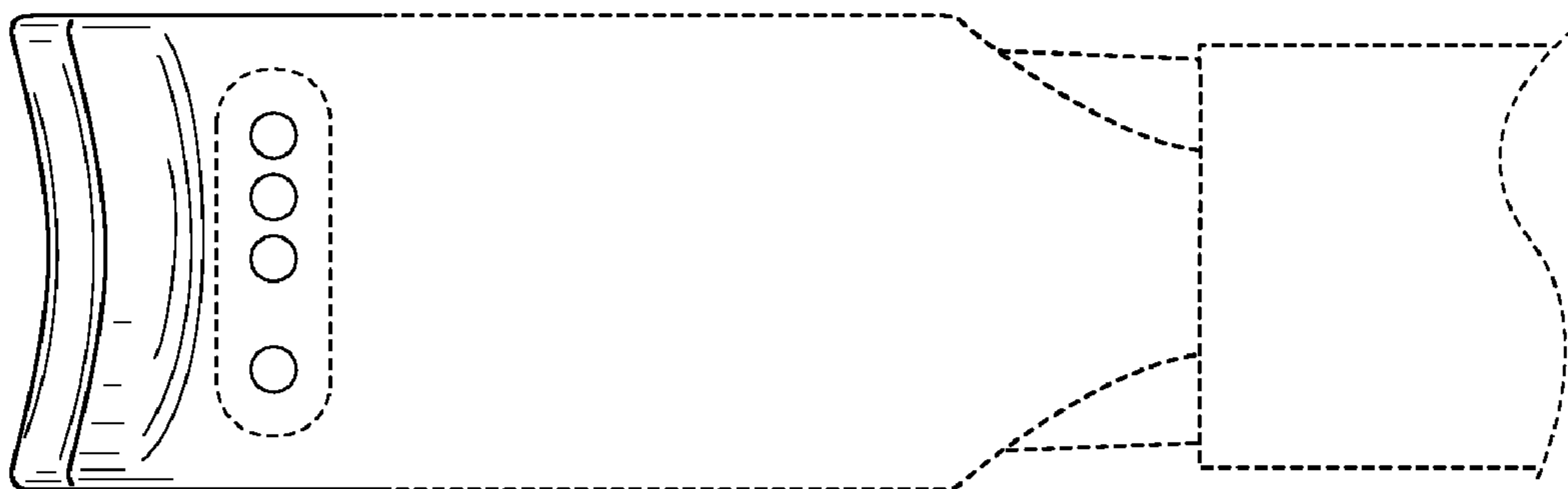

FIG. 40

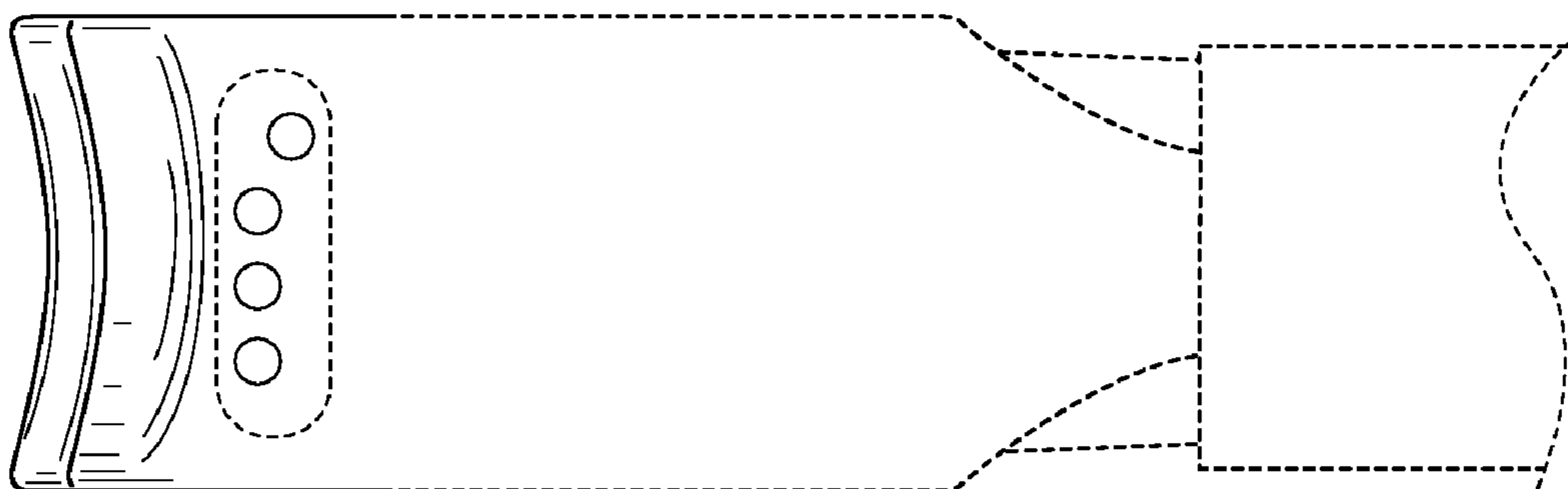
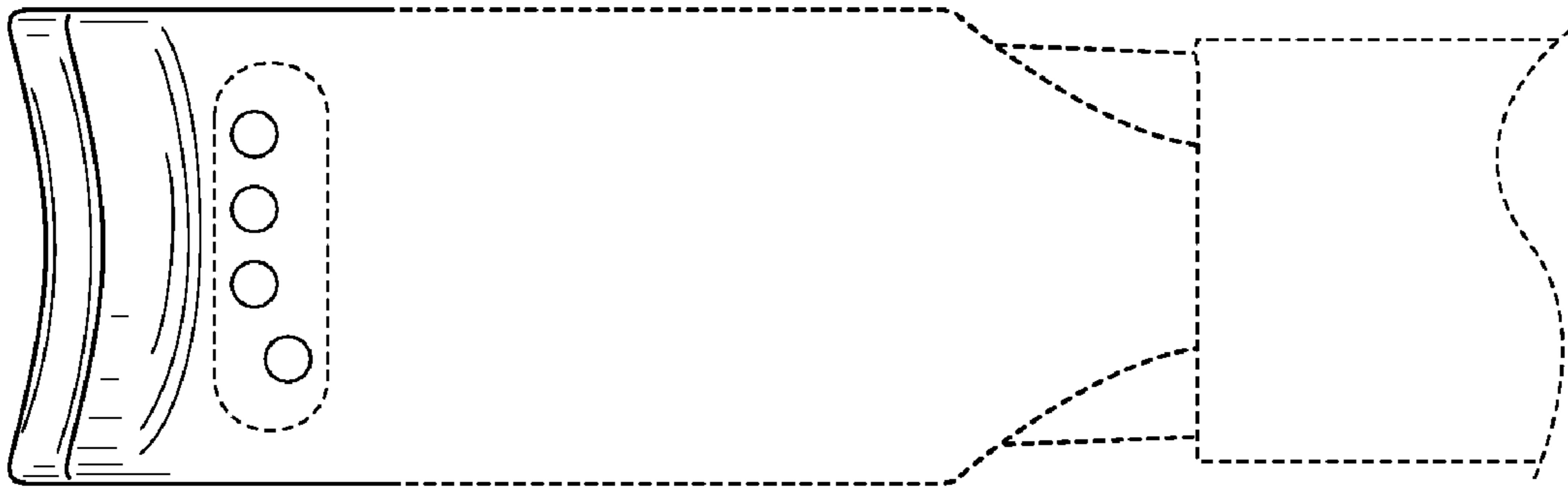
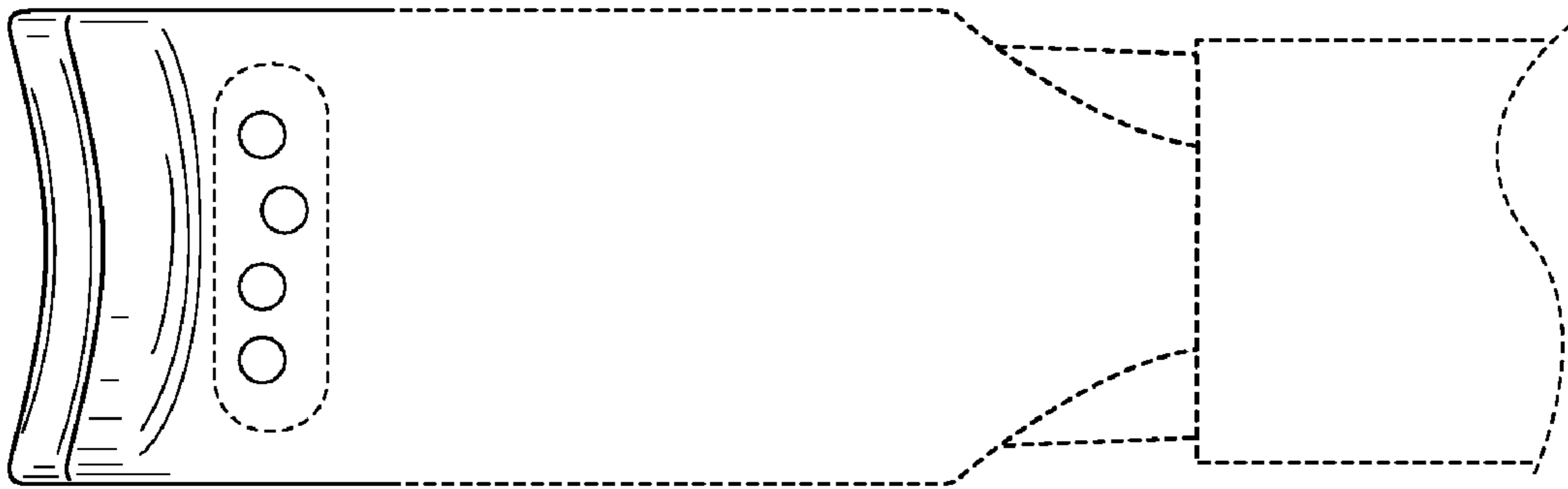

FIG. 41



**FIG. 42**



**FIG. 43**

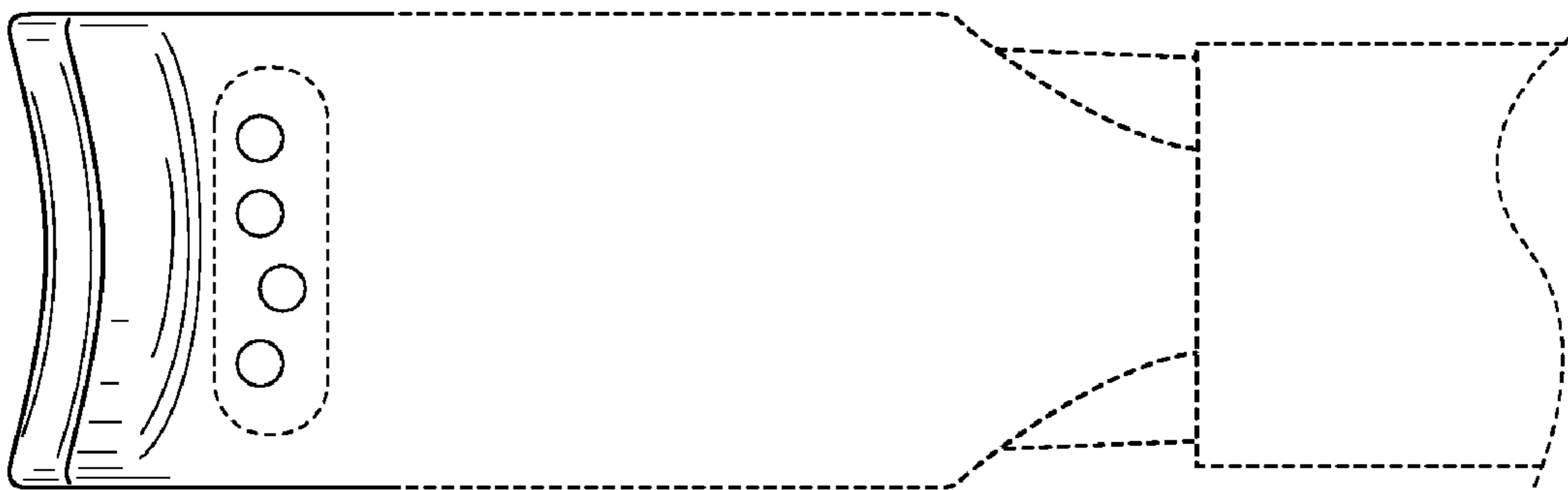

**FIG. 44**

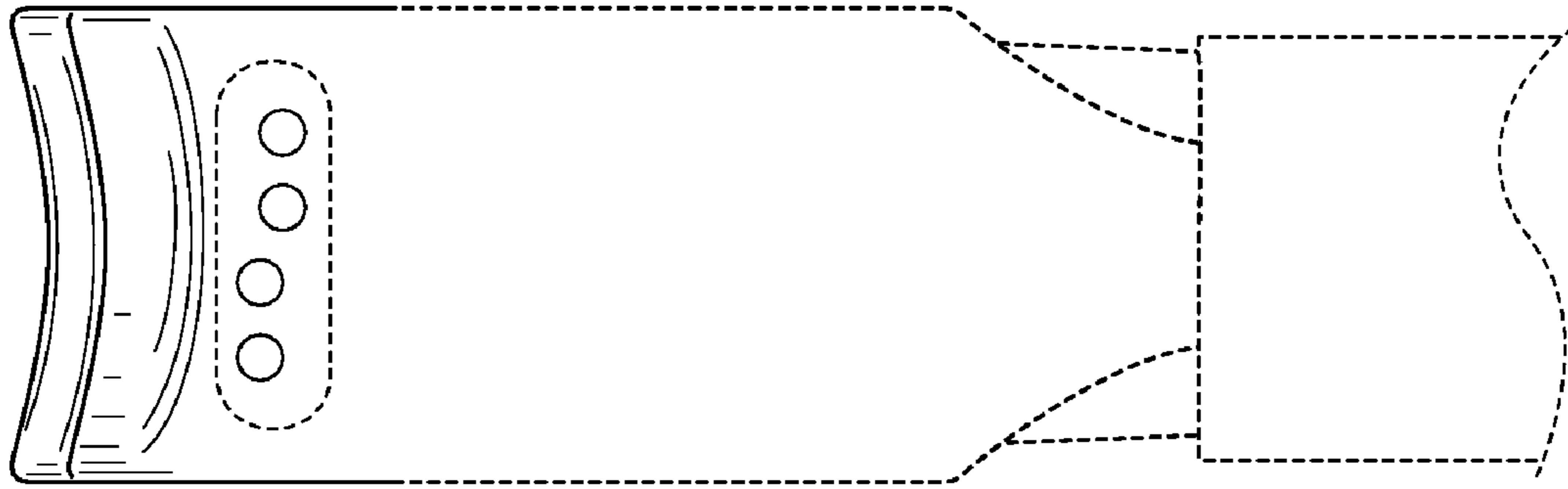

FIG. 45

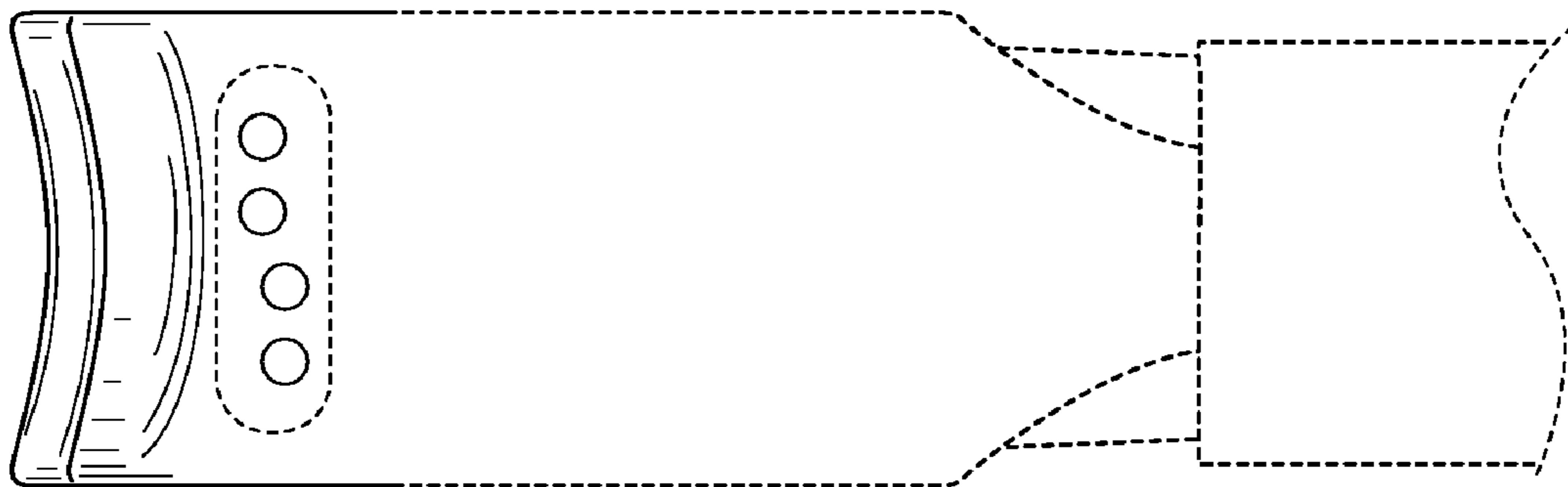

FIG. 46

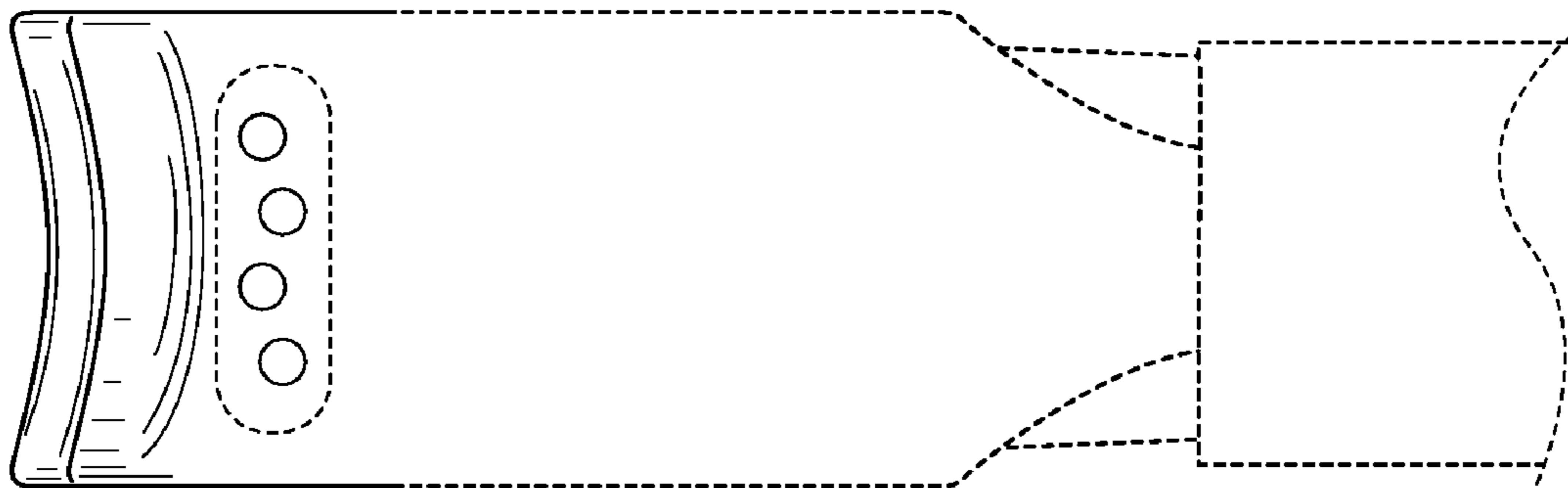

FIG. 47

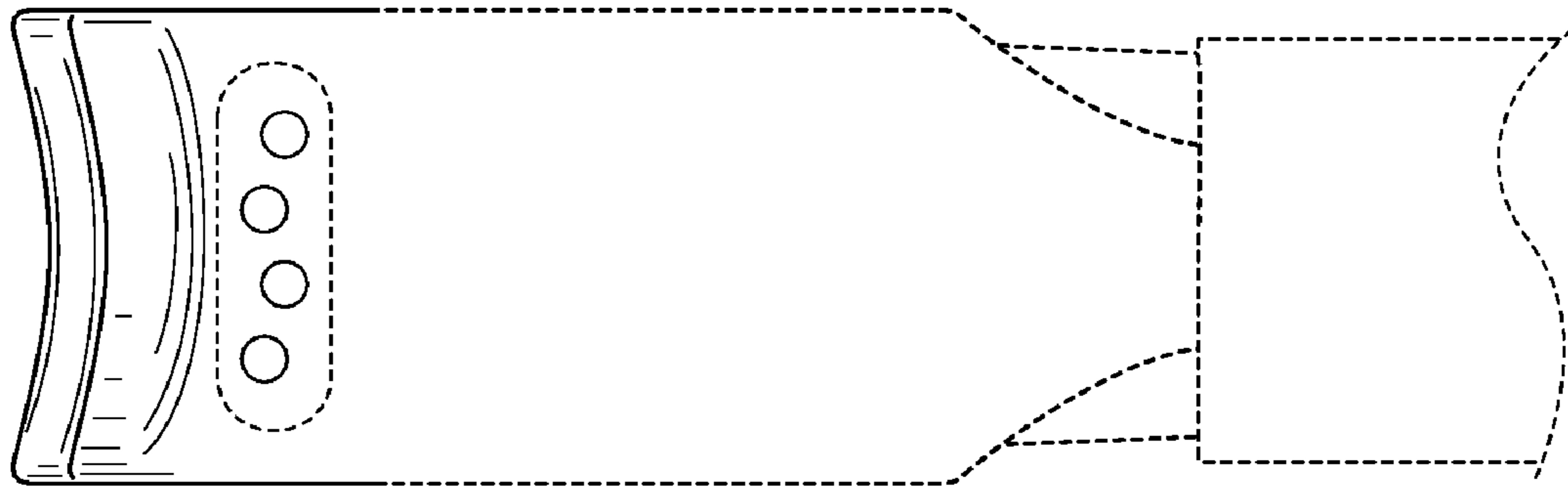

FIG. 48

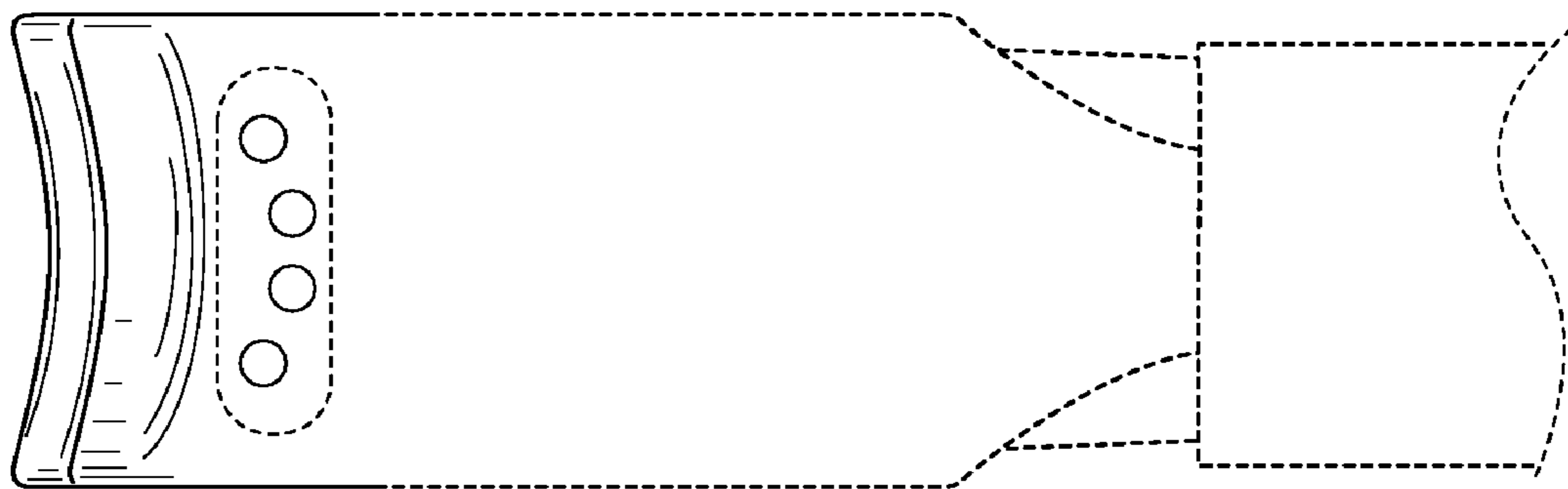

FIG. 49

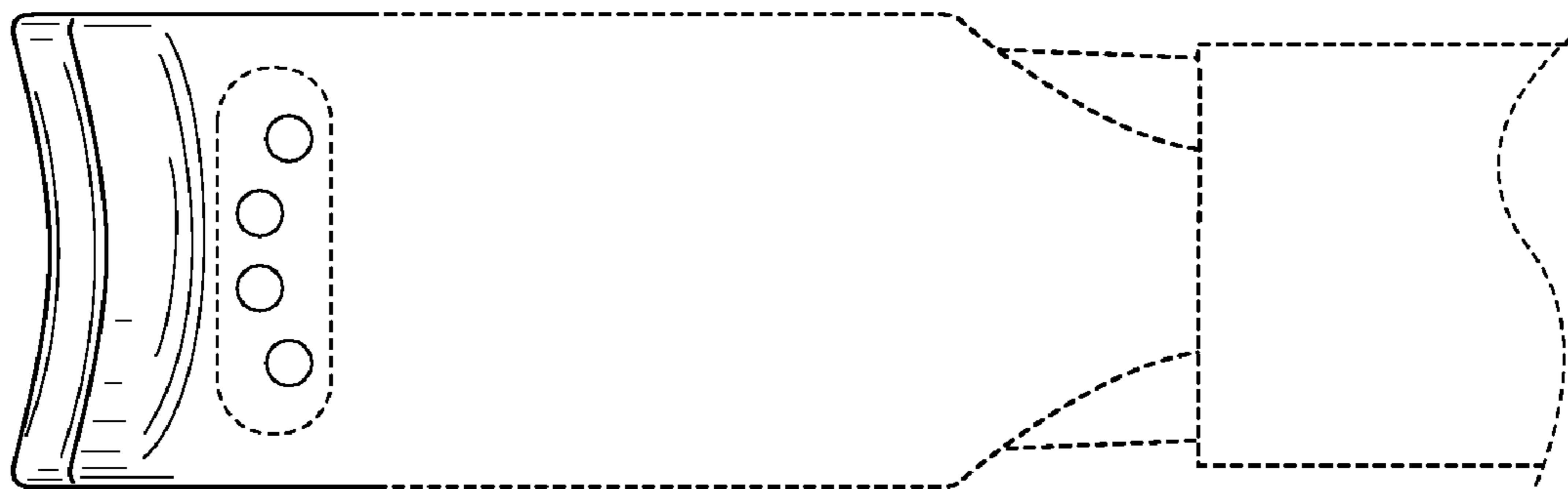

FIG. 50

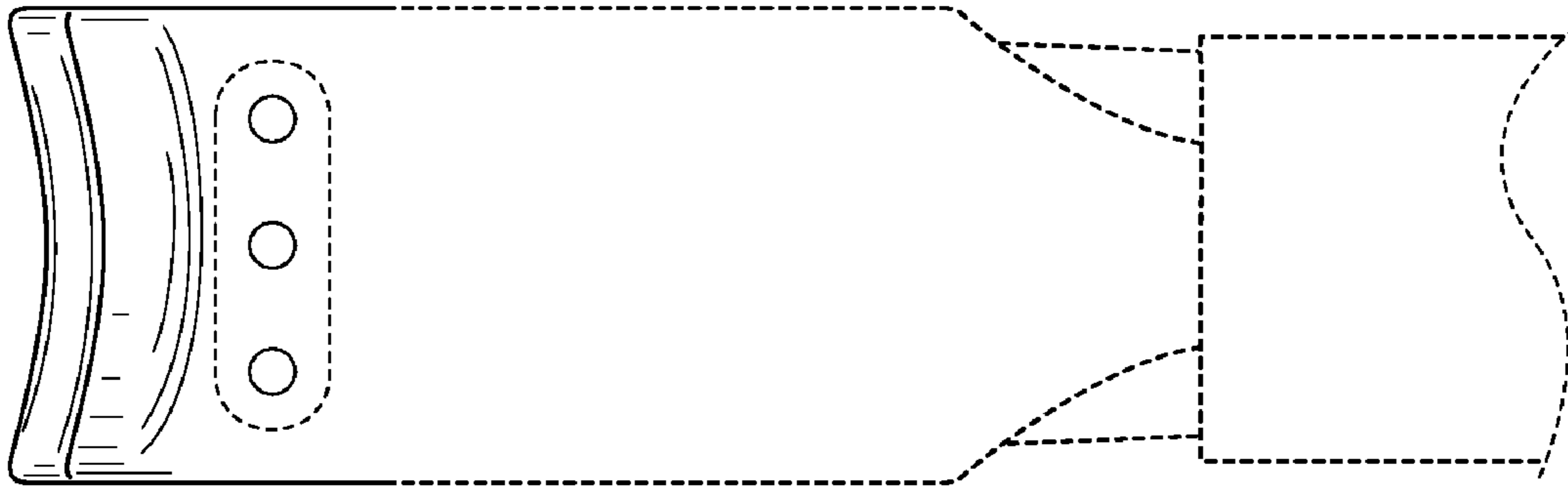

FIG. 51

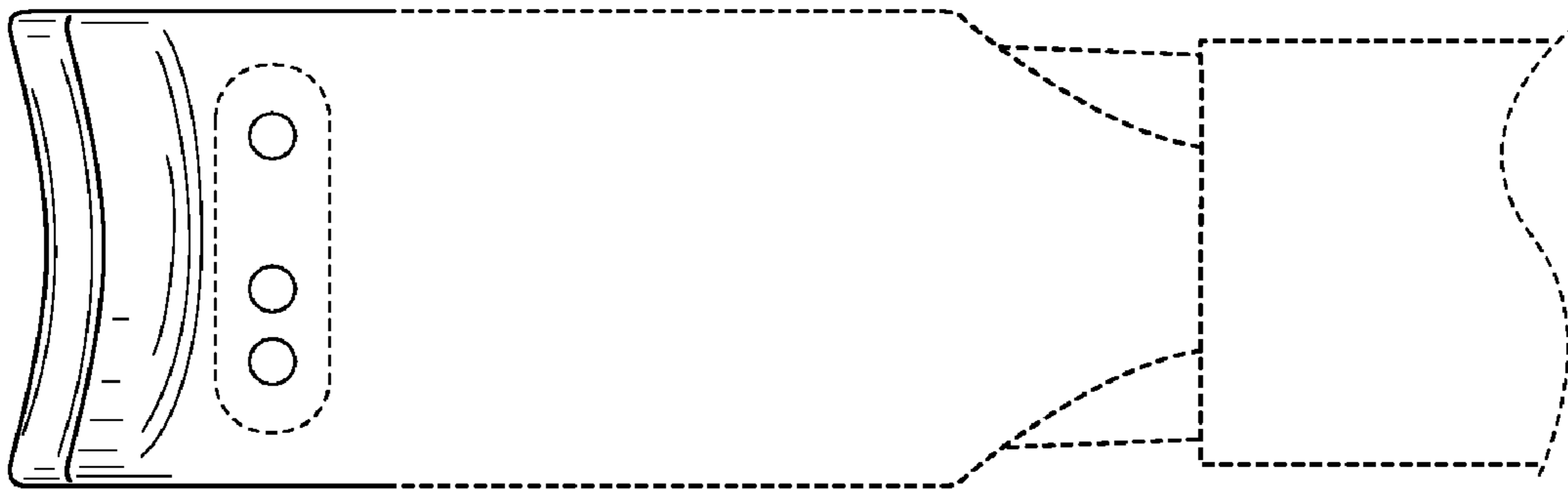

FIG. 52

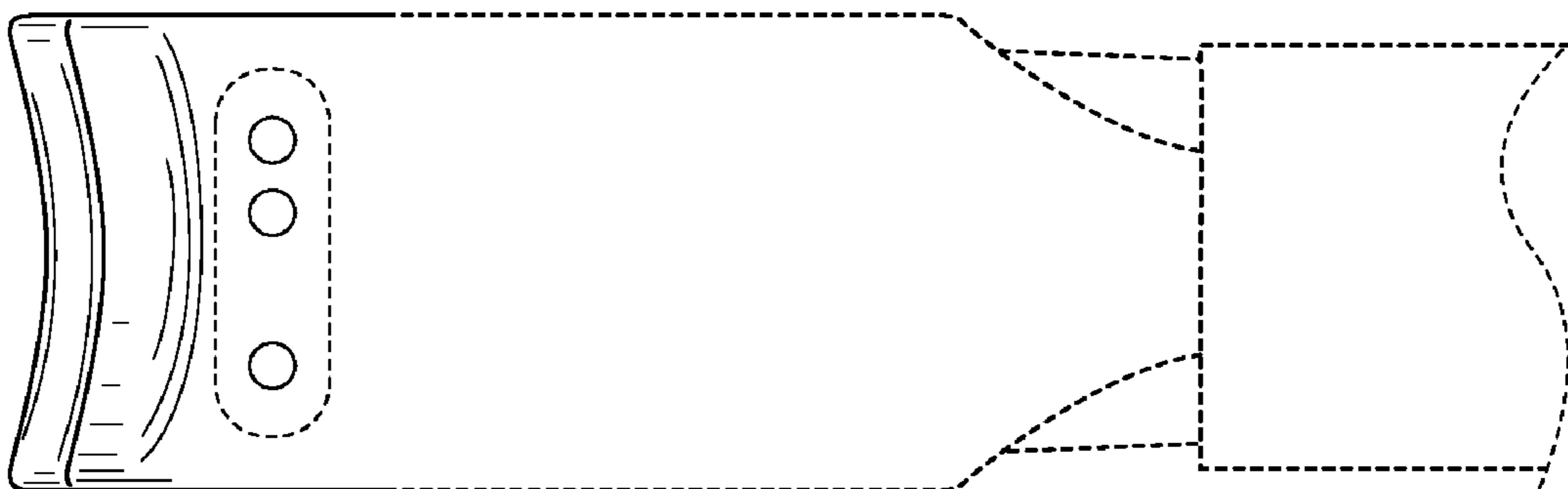

FIG. 53

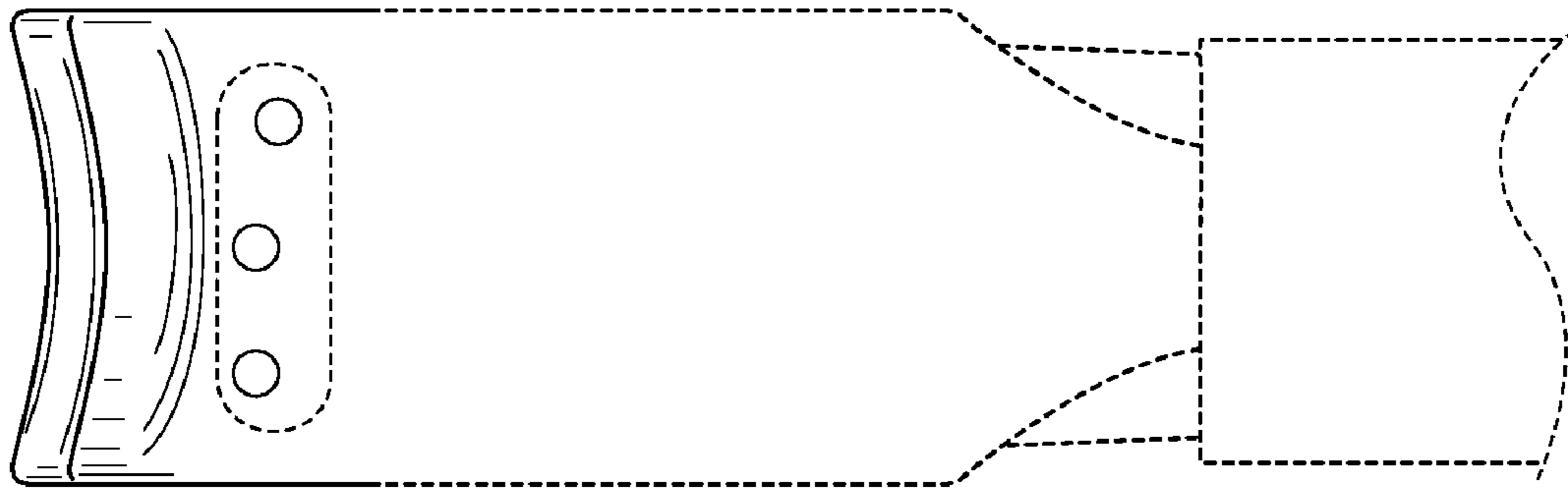

FIG. 54

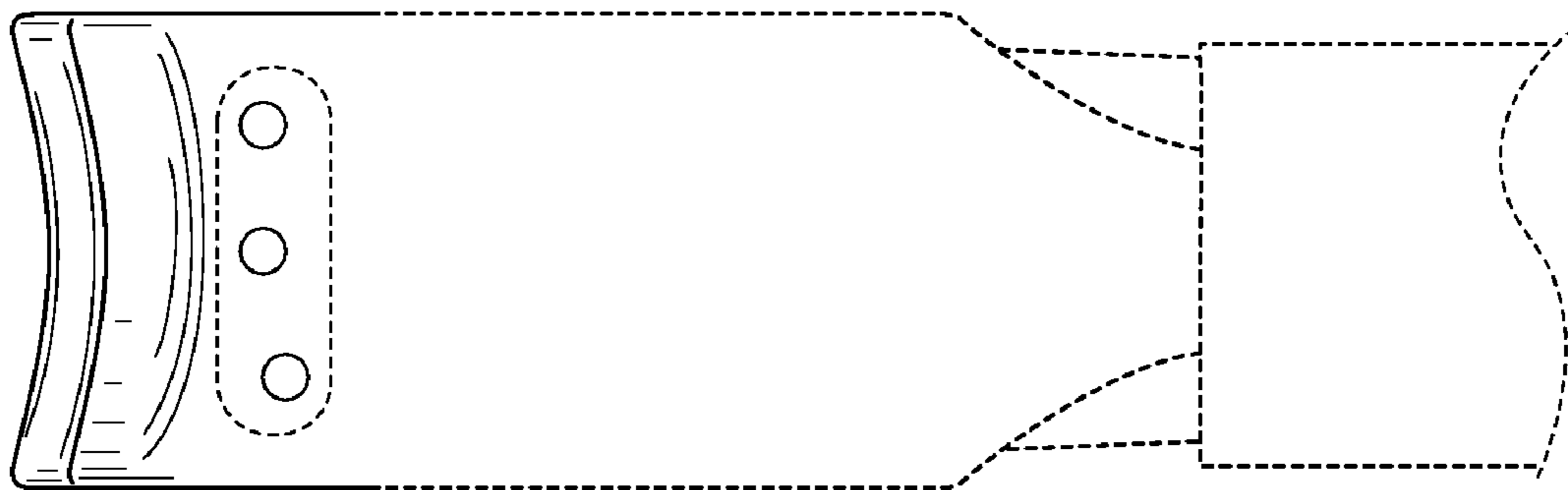

FIG. 55

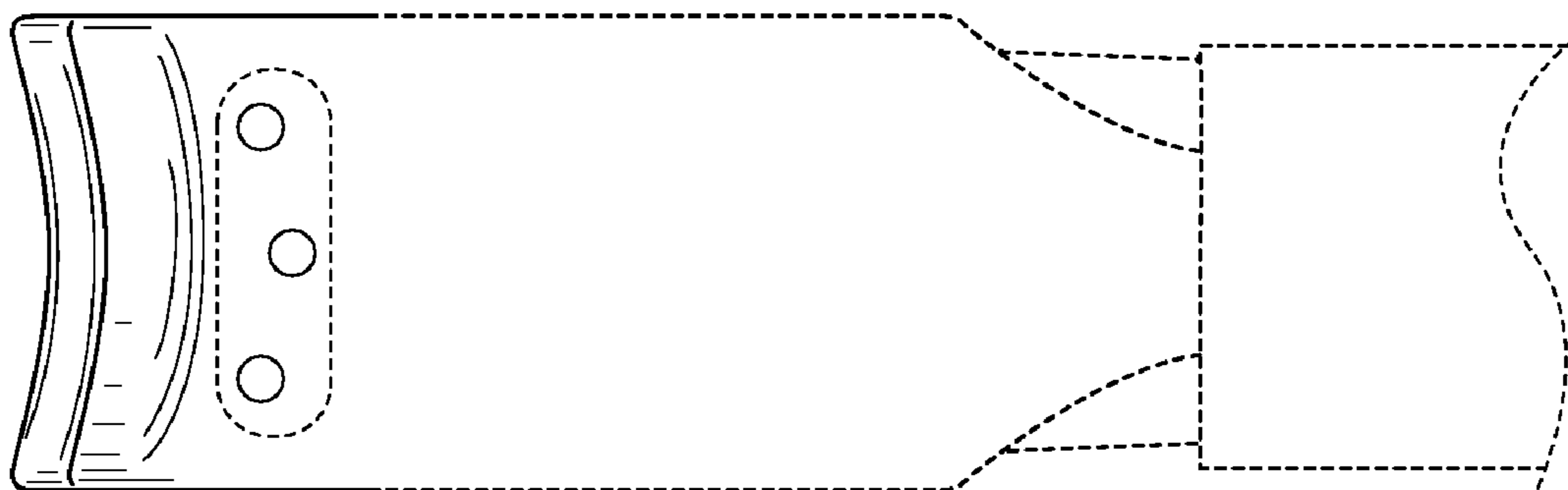
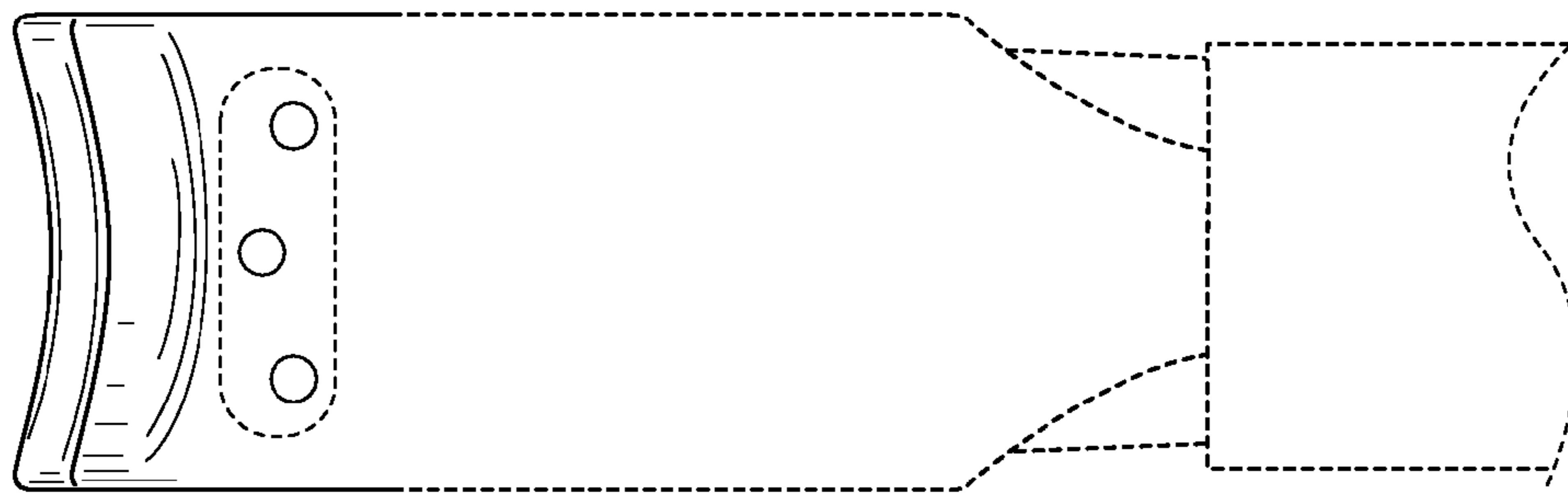
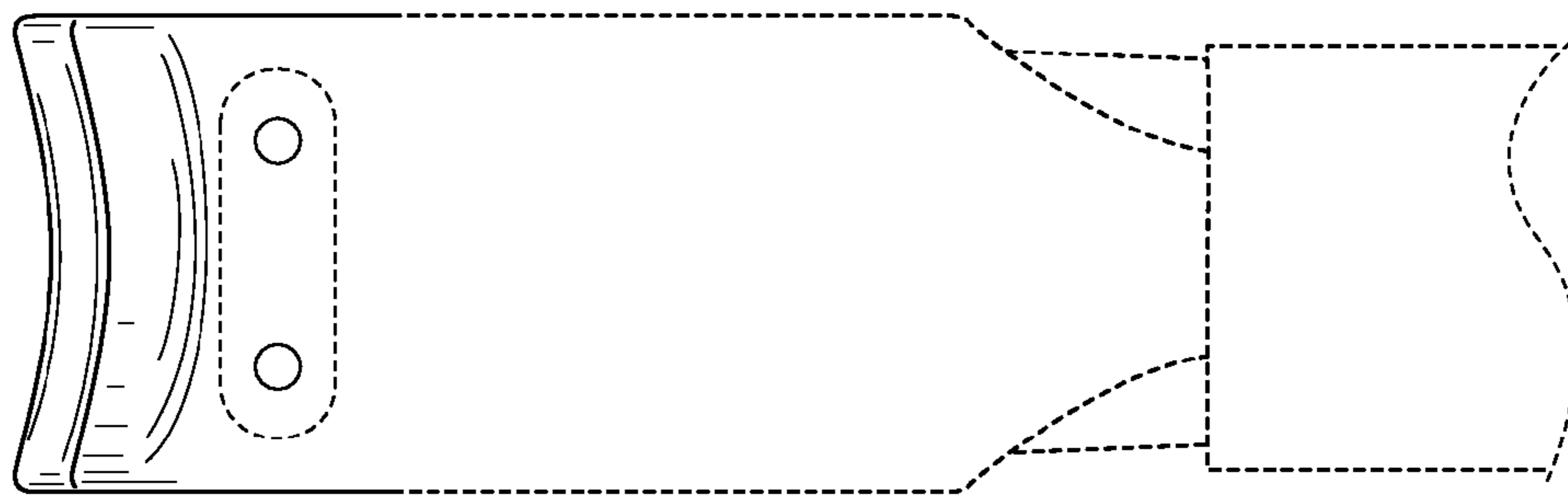

FIG. 56



**FIG. 57**



**FIG. 58**

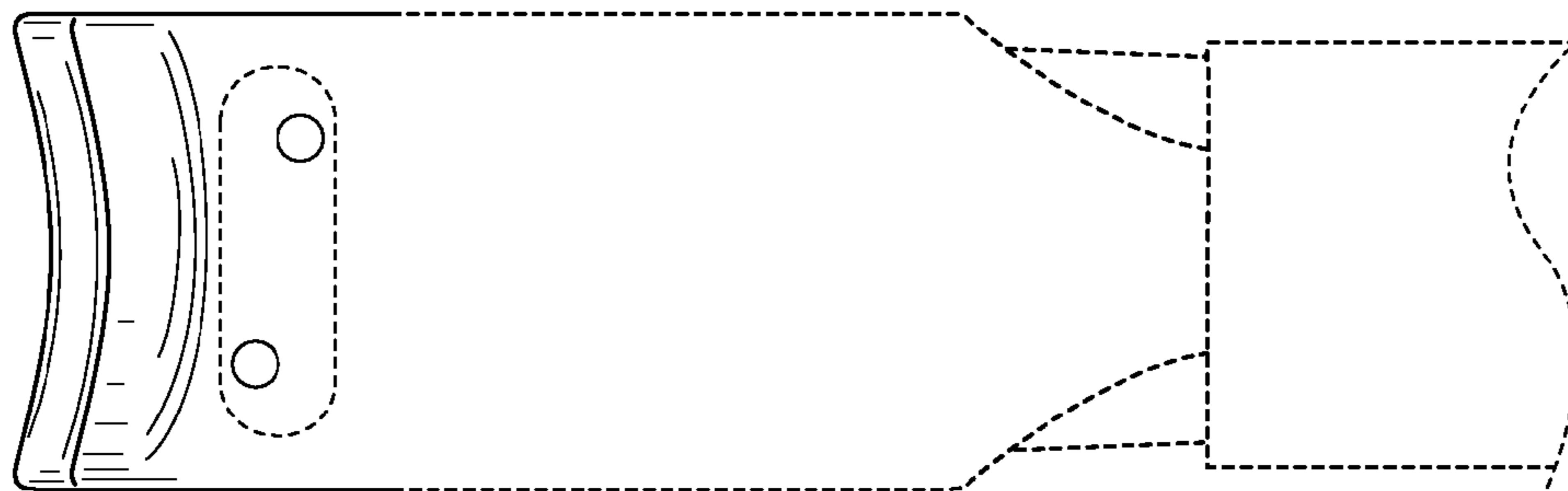

**FIG. 59**

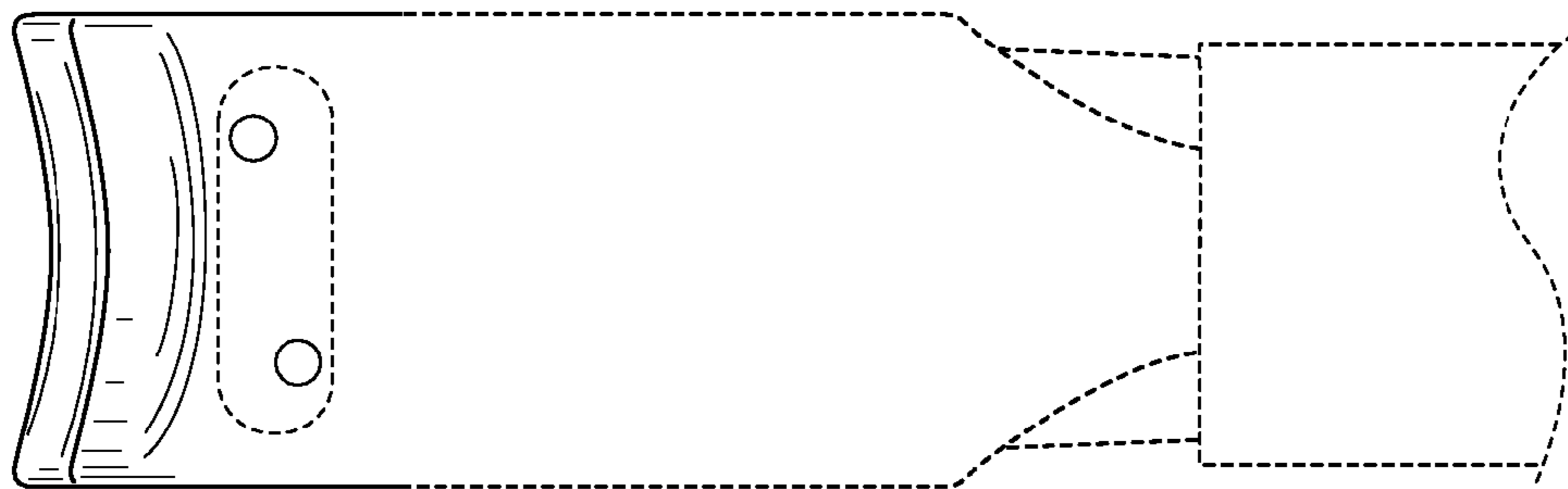

**FIG. 60**