



US00D574768S

(12) **United States Design Patent**  
**Witte**

(10) **Patent No.:** **US D574,768 S**

(45) **Date of Patent:** **\*\* Aug. 12, 2008**

(54) **RECHARGEABLE BATTERY PACK**

(75) Inventor: **Waldemar Witte**, Mainz (DE)

(73) Assignee: **Witte + Sutor GmbH**, Murrhardt (DE)

(\*\*) Term: **14 Years**

(21) Appl. No.: **29/224,192**

(22) Filed: **Feb. 28, 2005**

(30) **Foreign Application Priority Data**

Sep. 2, 2004 (EM) ..... 000240874

(51) **LOC (8) Cl.** ..... **13-02**

(52) **U.S. Cl.** ..... **D13/103**

(58) **Field of Classification Search** ..... D13/102–106,  
D13/110, 118–119, 184; 429/96–100, 163,  
429/176

See application file for complete search history.

(56) **References Cited**

**U.S. PATENT DOCUMENTS**

2,123,713	A	*	7/1938	Clark et al.	.....	361/539
D376,579	S	*	12/1996	Bunyea et al.	.....	D13/103
D388,051	S	*	12/1997	Harada et al.	.....	D13/103
D392,249	S	*	3/1998	Nakazawa et al.	.....	D13/103
D393,829	S	*	4/1998	Shimizu	.....	D13/103
D413,565	S	*	9/1999	Nakayama	.....	D13/103
D413,858	S	*	9/1999	Murakami et al.	.....	D13/103
D427,140	S	*	6/2000	Luh et al.	.....	D13/103
D427,141	S	*	6/2000	Luh et al.	.....	D13/103
D427,142	S	*	6/2000	Luh et al.	.....	D13/103
D428,385	S	*	7/2000	Luh et al.	.....	D13/103
D457,131	S	*	5/2002	Kitoh et al.	.....	D13/103

D459,297 S \* 6/2002 Searle ..... D13/103

\* cited by examiner

*Primary Examiner*—Jennifer Rivard

*Assistant Examiner*—Rosemary K Tarcza

(74) *Attorney, Agent, or Firm*—Paul Vincent

(57) **CLAIM**

The ornamental design for a rechargeable battery pack, as shown and described.

**DESCRIPTION**

FIG. 1 shows a first top view of the rechargeable battery pack in accordance with the invention in a closed state;

FIG. 2 shows a first perspective end view of the rechargeable battery pack in accordance with the invention in the closed state;

FIG. 3 shows a second perspective end view of the rechargeable battery pack in accordance with the invention in the closed state;

FIG. 4 shows a second substantially top view of the rechargeable battery pack in accordance with the invention in a partially opened state;

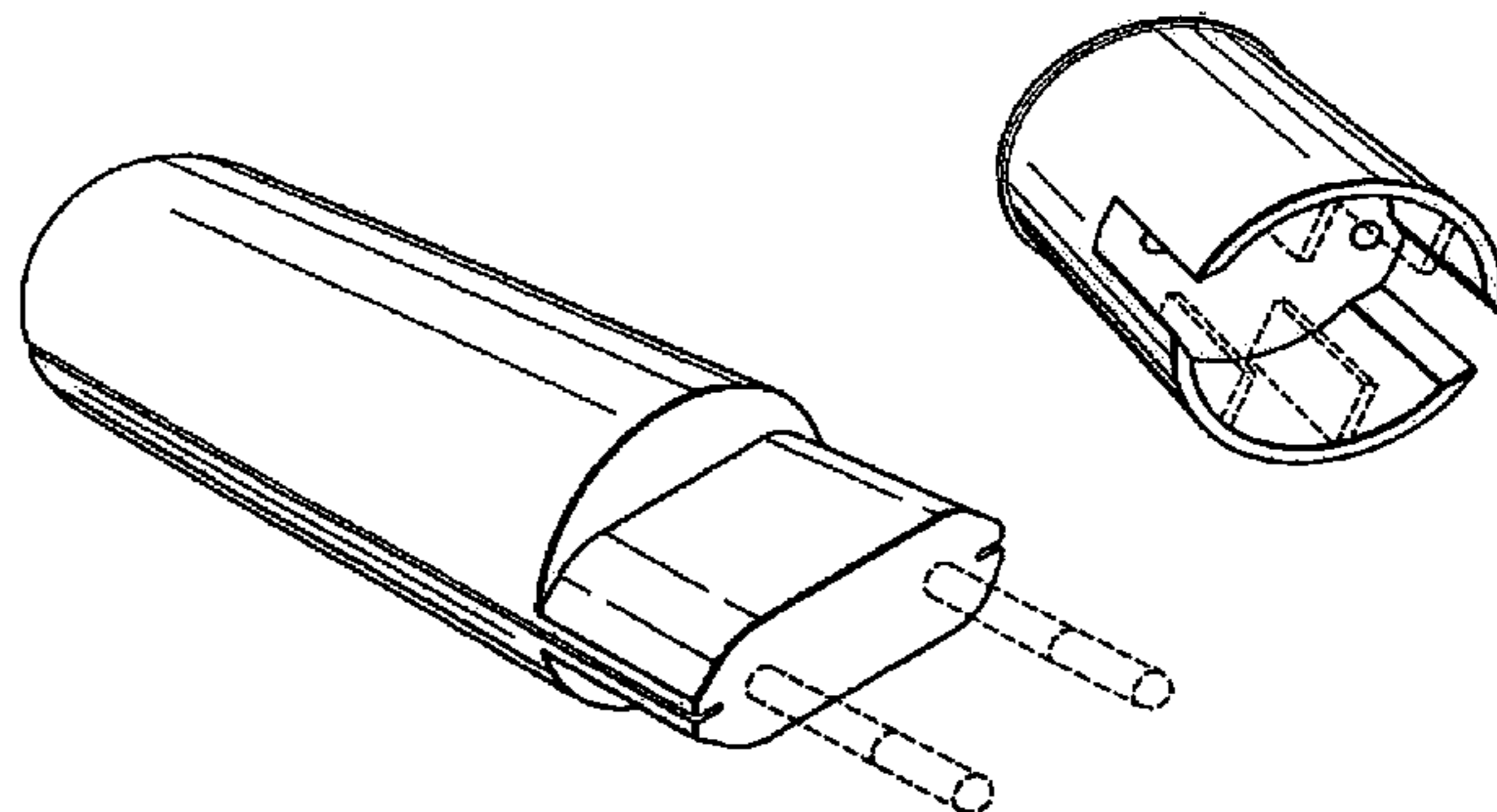
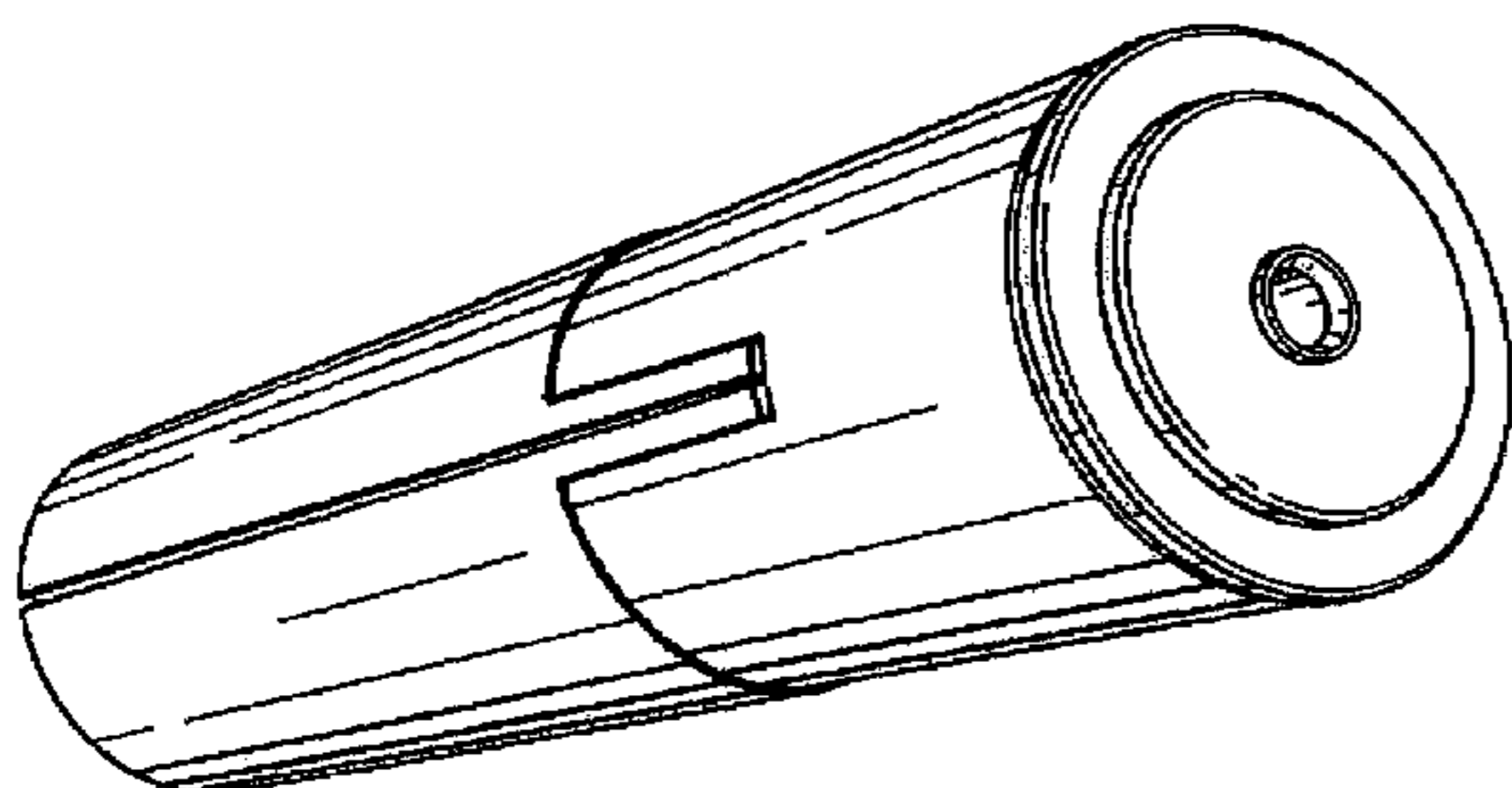
FIG. 5 shows a third top view of the rechargeable battery pack in accordance with the invention in an opened state;

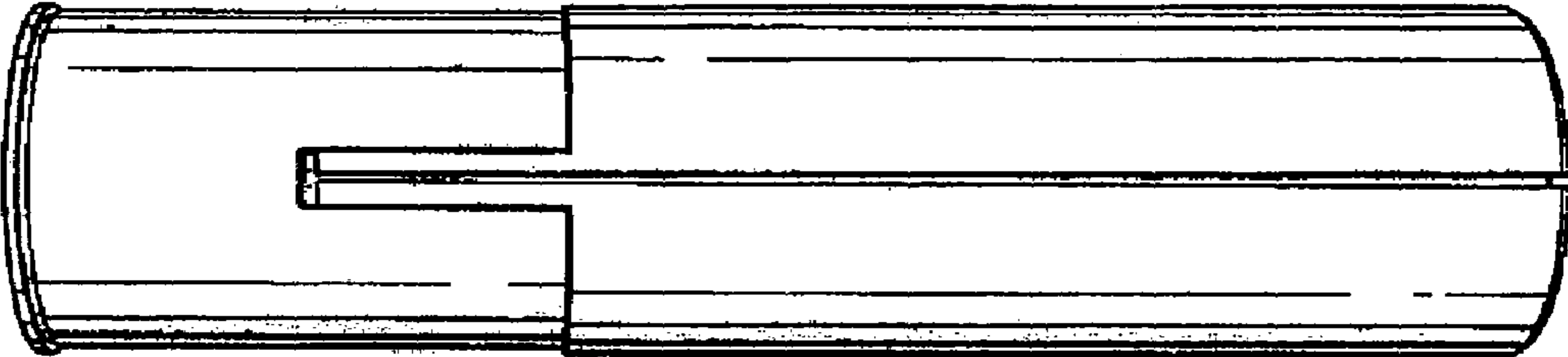
FIG. 6 shows a first side view of the rechargeable battery pack in accordance with the invention in the opened state; and,

FIG. 7 shows a third perspective end view of the rechargeable battery pack in accordance with the invention in the opened state.

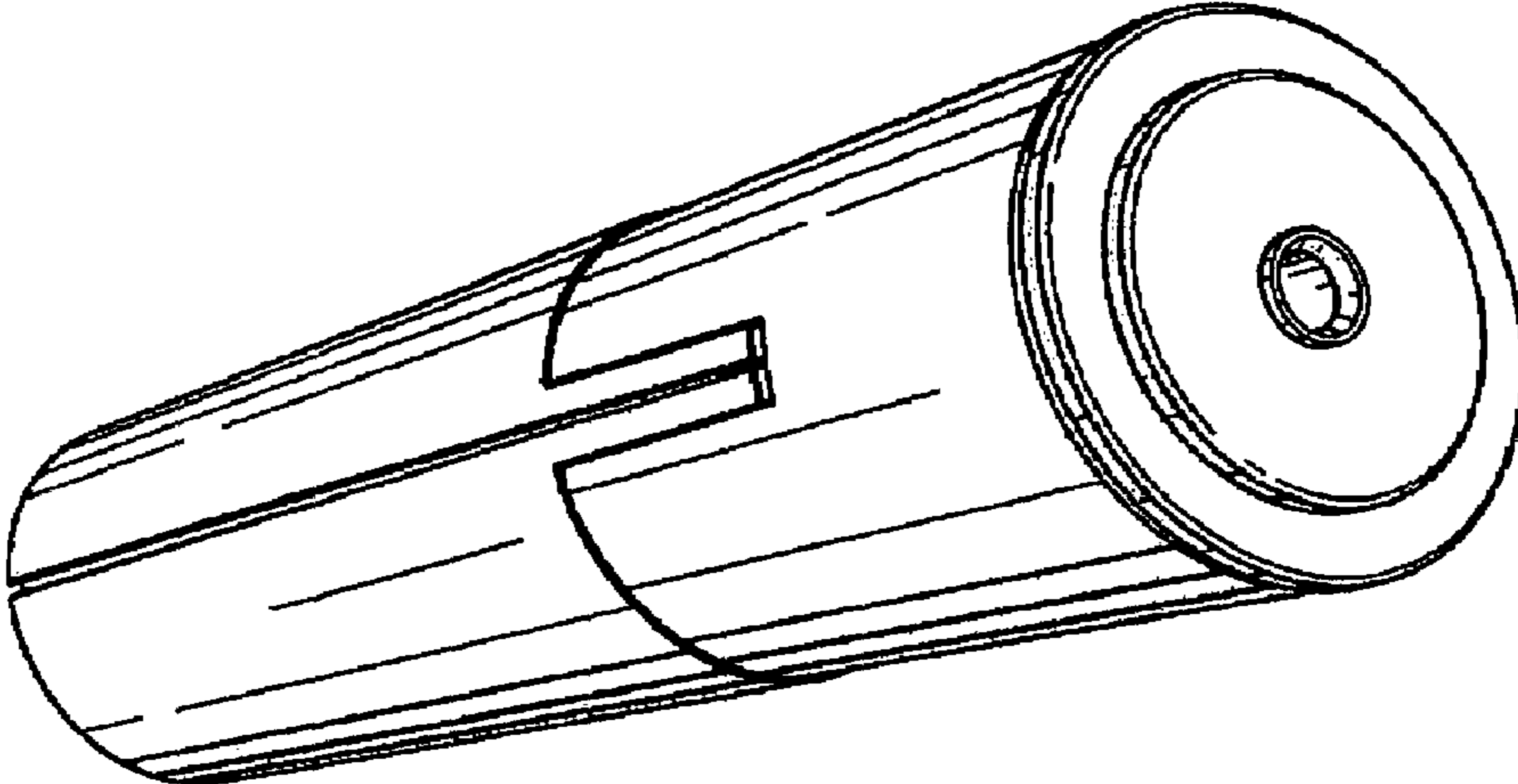
The portions of the design shown in broken lines form no part of the claimed design.

**1 Claim, 4 Drawing Sheets**

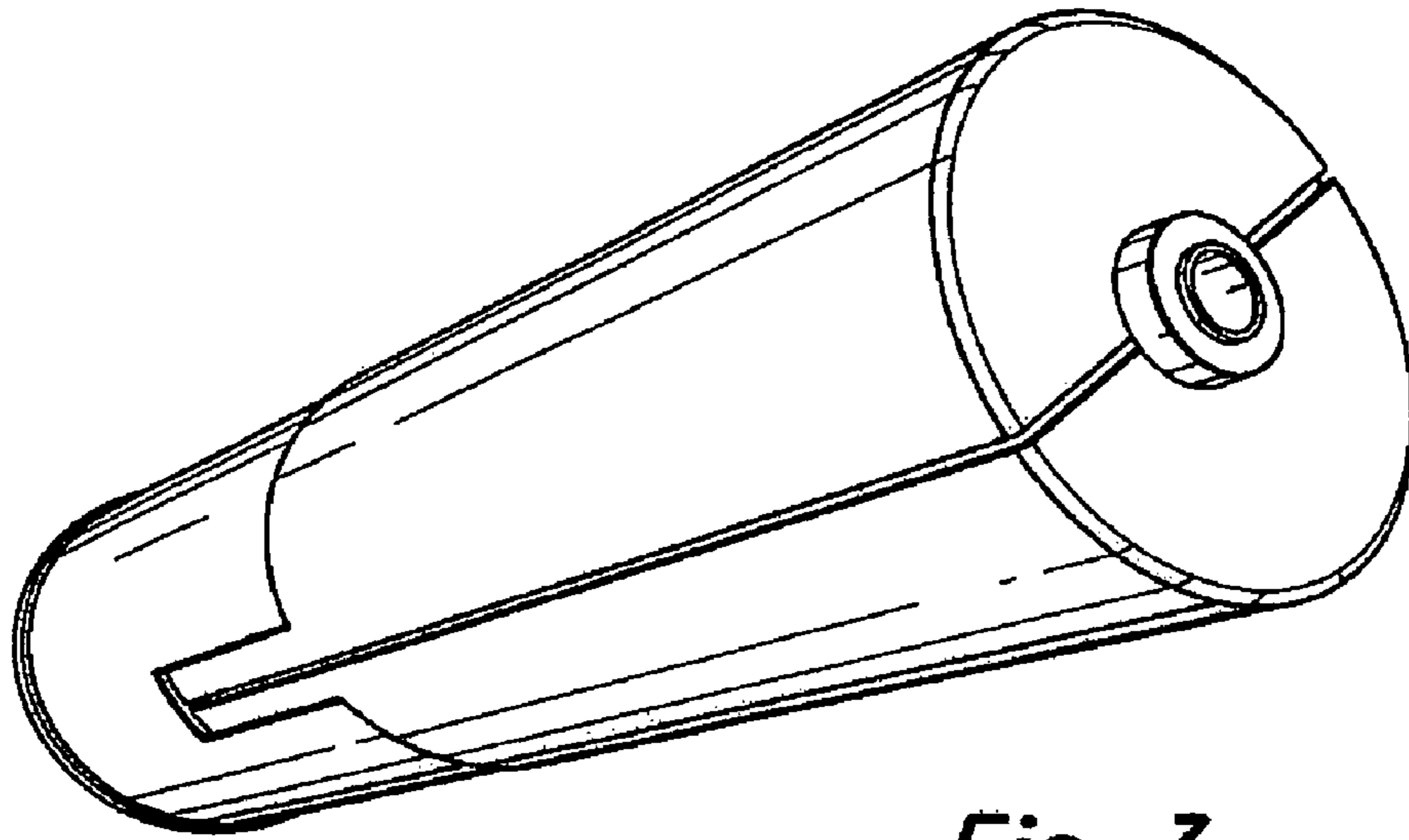




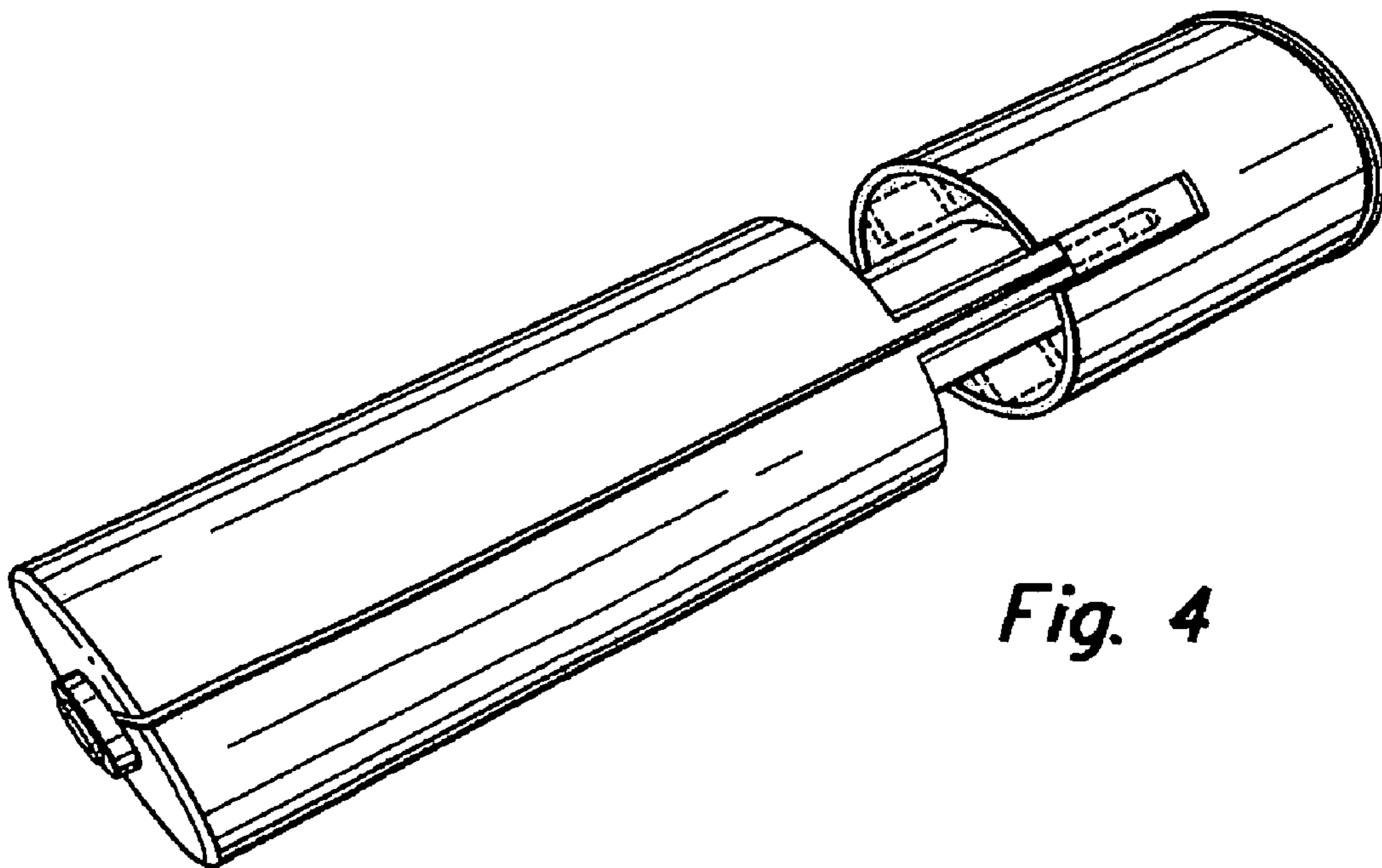
*Fig. 1*



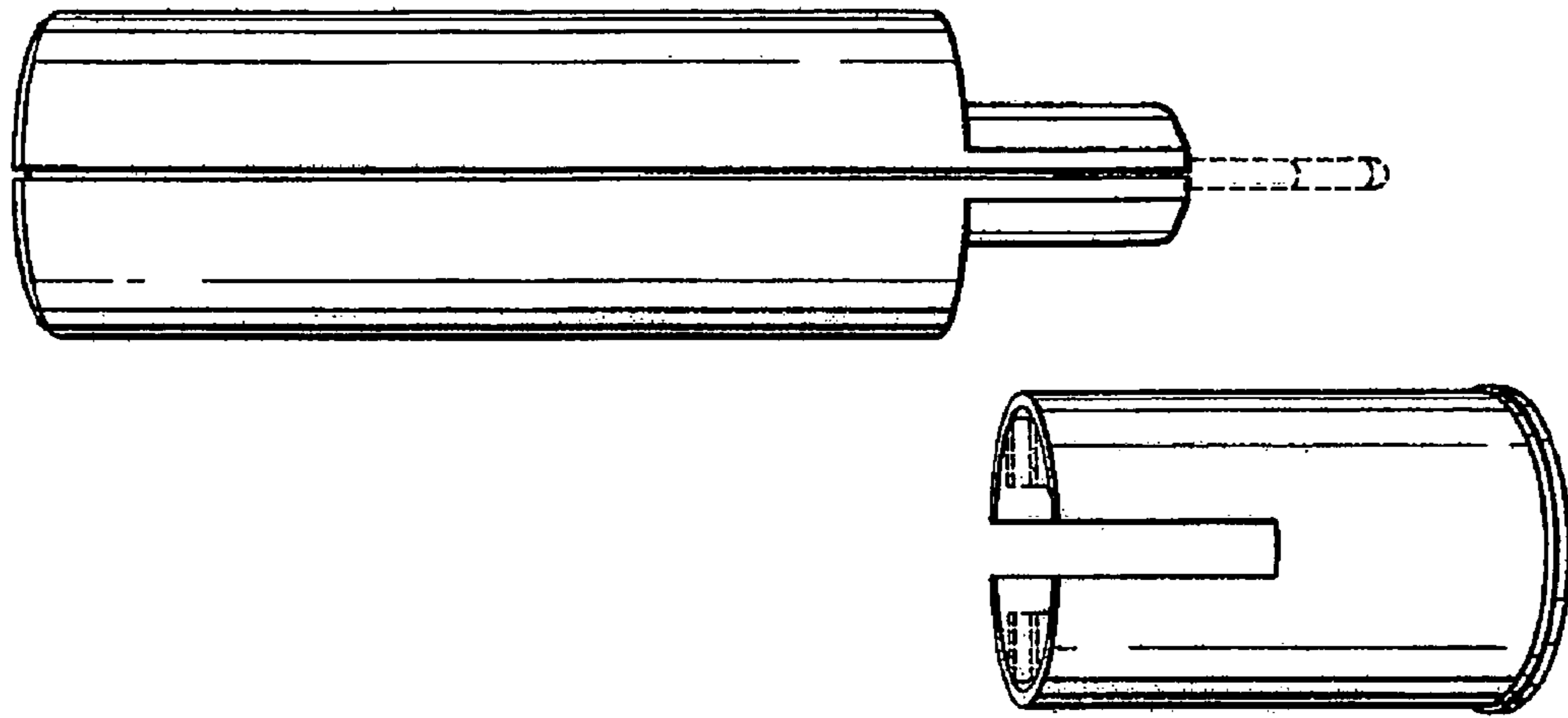
*Fig. 2*



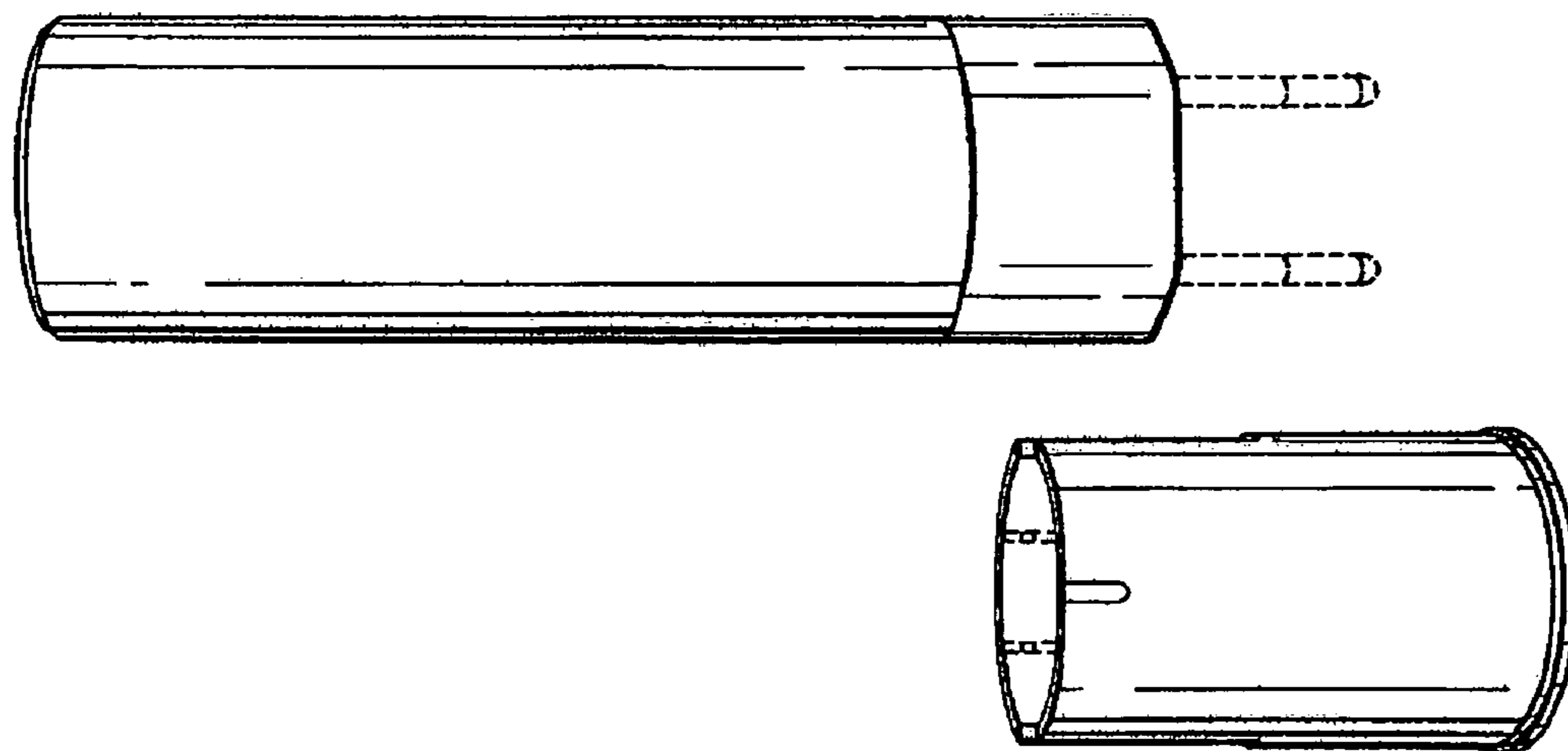
*Fig. 3*



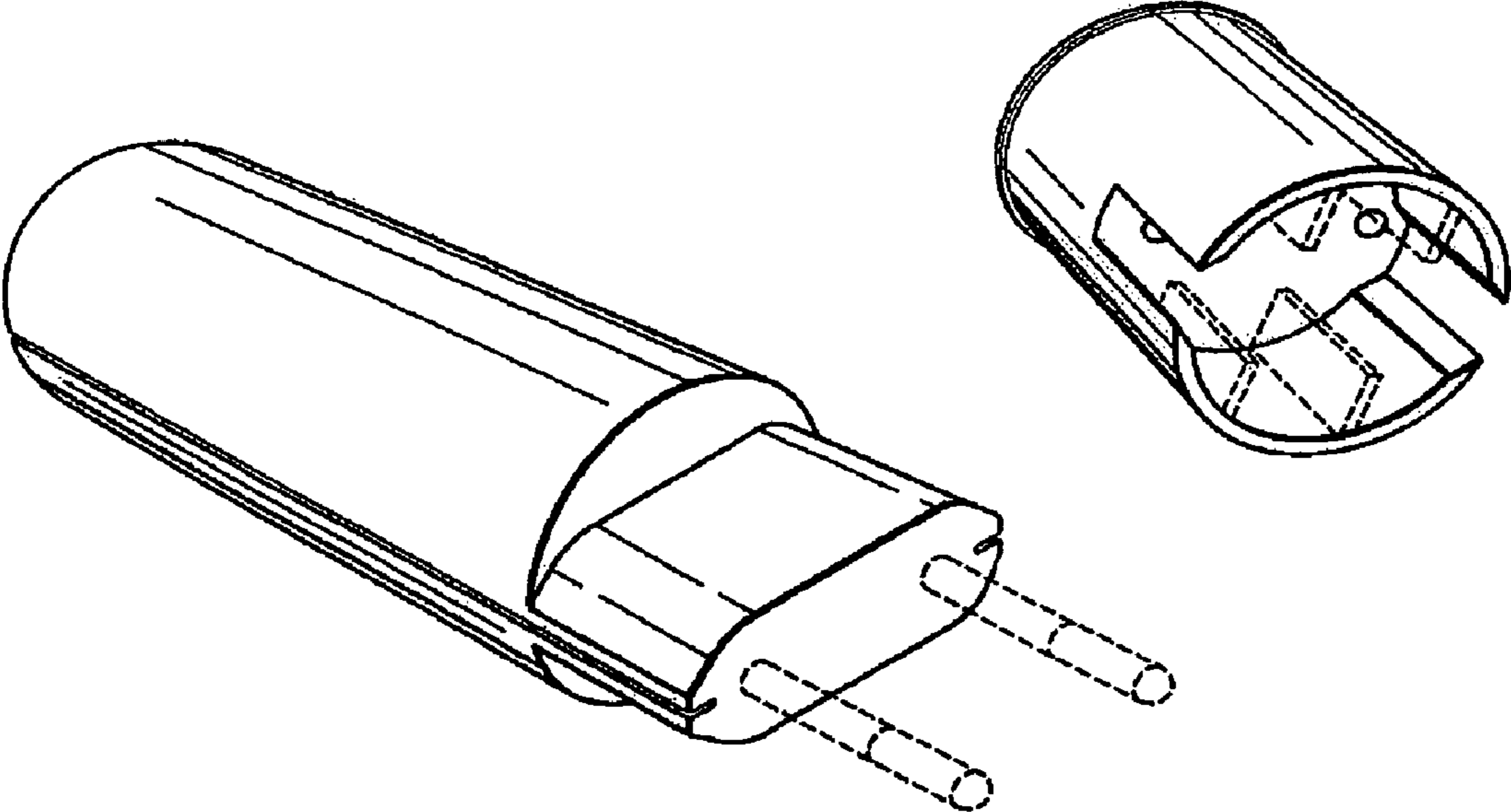
*Fig. 4*



*Fig. 5*



*Fig. 6*



*Fig. 7*