



US00D574763S

(12) **United States Design Patent**
Smith et al.

(10) **Patent No.:** **US D574,763 S**
(45) **Date of Patent:** **** Aug. 12, 2008**

(54) **TONNEAU COVER**

2005/0140177 A1 6/2005 Montagna et al.

(75) Inventors: **Leslie E. Smith**, Knoxville, TN (US);
John C. Montagna, Metamora, MI (US);
Thomas G. Sierakowski, Metamora, MI (US);
Vincent B. Rocheleau, Metamora, MI (US);
William Matthew McCreedy, Leonard, MI (US)

FOREIGN PATENT DOCUMENTS

WO WO/2005/065123 A2 7/2005

(73) Assignee: **Durakon Industries, Inc.**, Lapeer, MI (US)

OTHER PUBLICATIONS

Montagna et al., U.S. Appl. No. 60/716,270, filed Sep. 12, 2005.

(**) Term: **14 Years**

* cited by examiner

Primary Examiner—Robert M. Spear

Assistant Examiner—Katrina A Kile

(74) *Attorney, Agent, or Firm*—Christopher John Rudy

(21) Appl. No.: **29/238,298**

(57) **CLAIM**

(22) Filed: **Sep. 13, 2005**

The ornamental design for a tonneau cover, as shown and described.

(51) **LOC (8) Cl.** **12-16**

(52) **U.S. Cl.** **D12/401**

(58) **Field of Classification Search** D12/400–401;
296/98–100, 136, 100.1, 39.1, 39.2; 160/26,
160/33, 133; 150/154, 166; 280/770, 847
See application file for complete search history.

DESCRIPTION

FIG. 1 is a top view of a tonneau cover showing our new design, depicted as having a generally indeterminate length from front to rear, noting that frequently the cover is embodied in lengths about from four and one half to six and one half feet;

(56) **References Cited**

U.S. PATENT DOCUMENTS

D343,602 S *	1/1994	Brown	D12/401
D350,108 S *	8/1994	Blanchard	D12/401
5,743,586 A	4/1998	Nett	296/100
5,951,095 A *	9/1999	Herndon	296/165
D421,736 S *	3/2000	Bogard	D12/401
D424,509 S *	5/2000	Meyers	D12/401
D438,507 S *	3/2001	Herndon	D12/401
D444,762 S *	7/2001	Werle et al.	D12/401
6,588,826 B1	7/2003	Muirhead		
6,627,018 B1	9/2003	O'Neill et al.	156/78
6,857,683 B2 *	2/2005	Myers	296/100.02
D513,226 S *	12/2005	Sancer	D12/401
7,140,673 B2	11/2006	Ito et al.		
7,147,273 B2	12/2006	Ikeda et al.		
7,163,253 B2	1/2007	Montagna et al.		
D547,310 S *	7/2007	Yoon	D14/315
7,318,618 B1 *	1/2008	Yue	296/100.06

FIG. 2 is a front, elevational view of the tonneau cover of FIG. 1, i.e., a view looking at the cover from what would be the cab of a pickup truck onto which the cover could be attached;

FIG. 3 is rear, elevational view of the tonneau cover of FIG. 1;

FIG. 4 is a left side, elevational view of the tonneau cover of FIG. 1, the right side being a mirror image whereof; and

FIG. 5 is a bottom view of the tonneau cover of FIG. 1, with the feature in dashed lines not part of our invention.

FIG. 6 is a bottom view of the tonneau cover as of FIG. 1, embodied to have an approximately six and one half foot length from front to rear, with the feature in dashed lines not part of our invention;

FIG. 7 is a cross-sectional view of the tonneau cover of FIG. 6, taken along 7—7 in FIG. 6, with the features in dashed lines not part of our design;

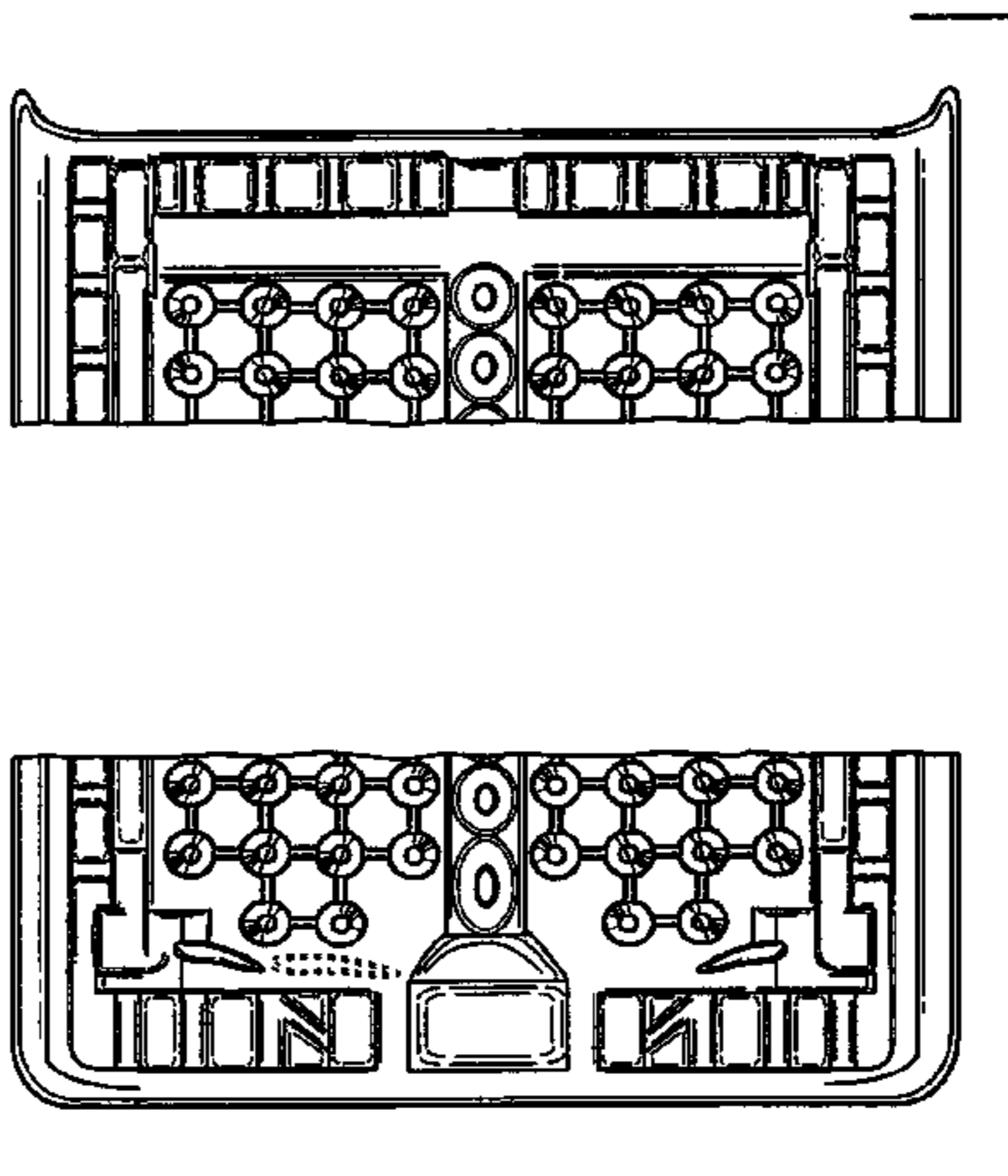
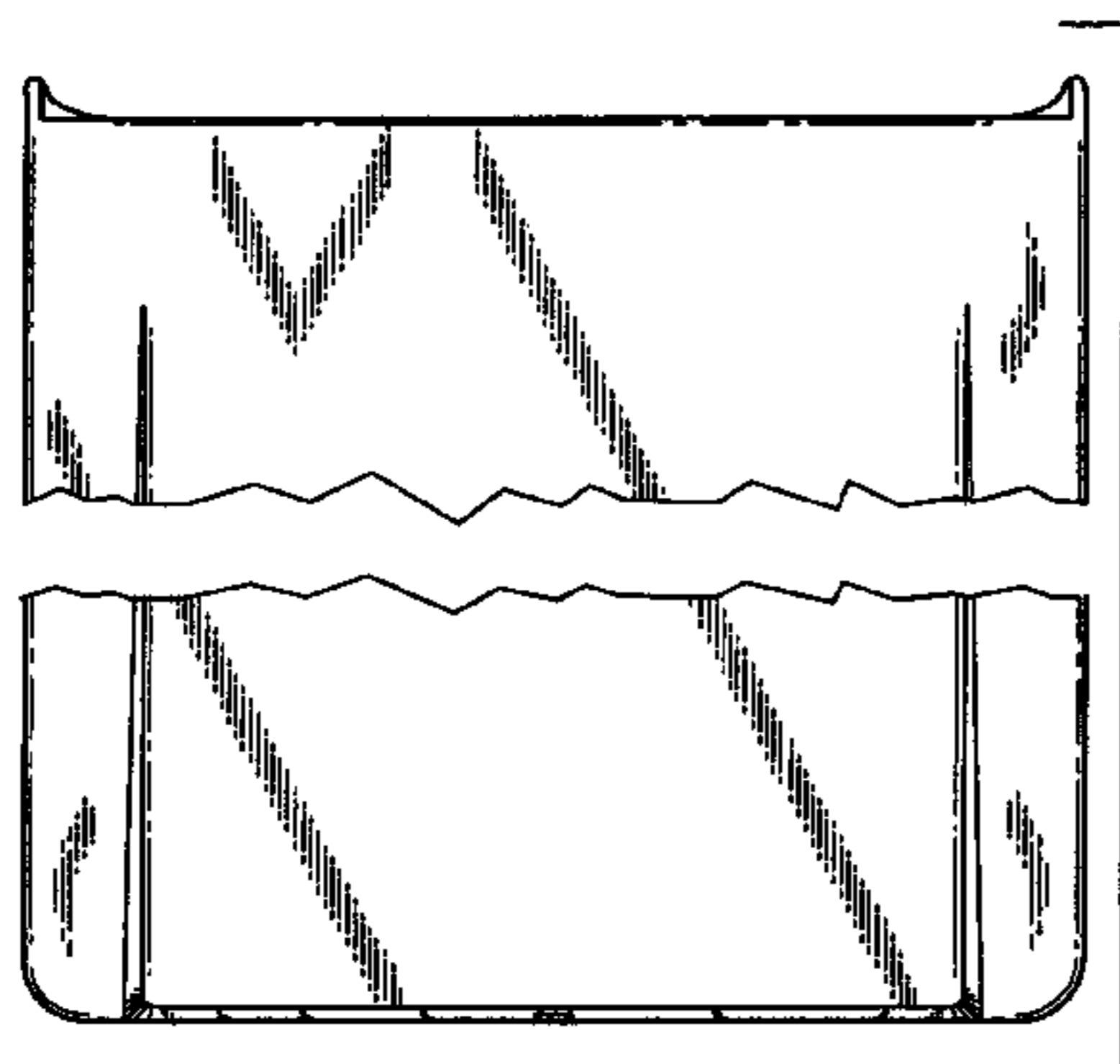

FIG. 8 is a cross-sectional view of the tonneau cover of FIG. 6, taken along 8—8 in FIG. 6, with the features in dashed lines not part of our design;

FIG. 9 is a cross-sectional view of the tonneau cover of FIG. 6, taken along 9—9 in FIG. 6, with the features in dashed lines not part of our design; and

FIG. 10 is a top view of the tonneau cover of FIG. 6.

FIG. 11 is a bottom view of the tonneau cover as of FIG. 1, embodied to have an approximately five and one half foot length from front to rear, with the feature in dashed lines not part of our invention;

FIG. 12 is a bottom, rear perspective view of the tonneau cover of FIG. 11, also viewing slightly from what would be the left side as determined from a top orientation, with the feature in dashed lines not part of our invention;

FIG. 13 is a bottom, front perspective view of the tonneau cover of FIG. 11, with the feature in dashed lines not part of our invention;

FIG. 14 is a top, rear perspective view of the tonneau cover of FIG. 11;

FIG. 15 is a top, front perspective view of the tonneau cover of FIG. 11; and

FIG. 16 is a top, left side perspective view of the tonneau cover of FIG. 11, with the features in dashed lines not part of our design; and,

FIG. 17 is a rear view of the tonneau cover of FIG. 11, in an environment mounted to a pickup truck bed and lifted to show its bottom, with the features in dashed lines not part of our design.

In the drawings, again, the broken lines depict environmental subject matter and form no part of the claimed design.

1 Claim, 8 Drawing Sheets

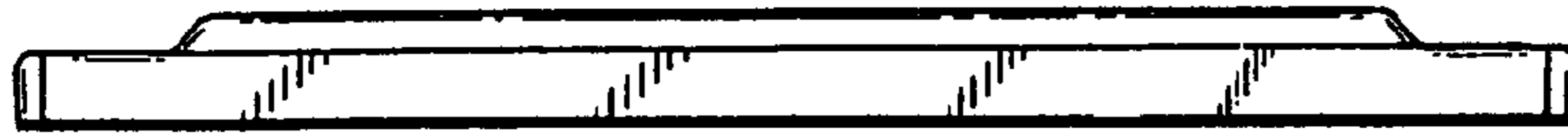

Fig. 2

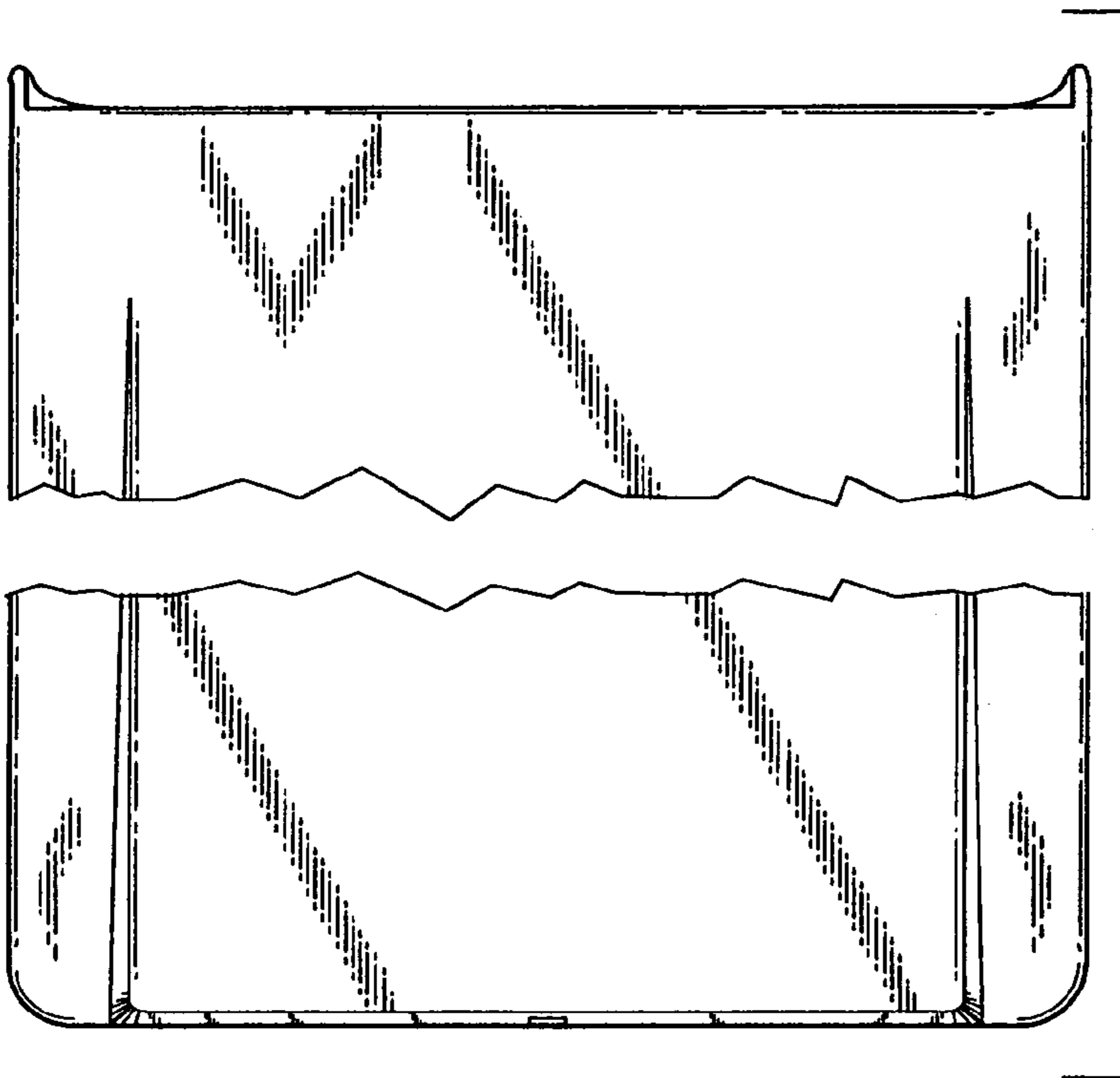

Fig. 1

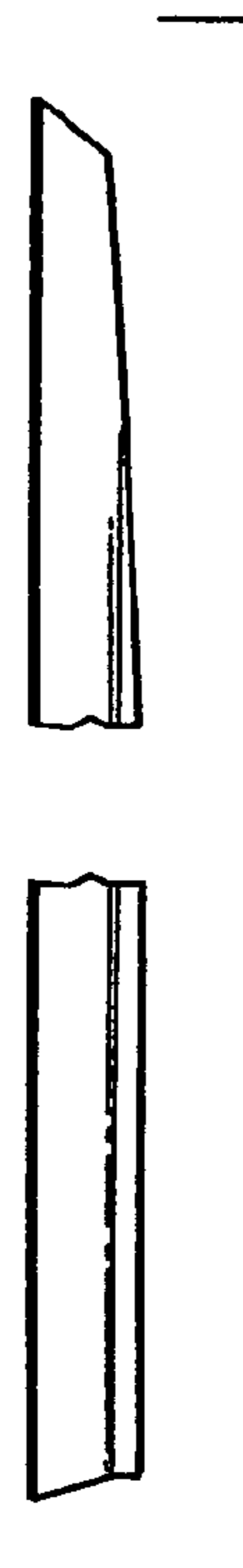

Fig. 4



Fig. 3

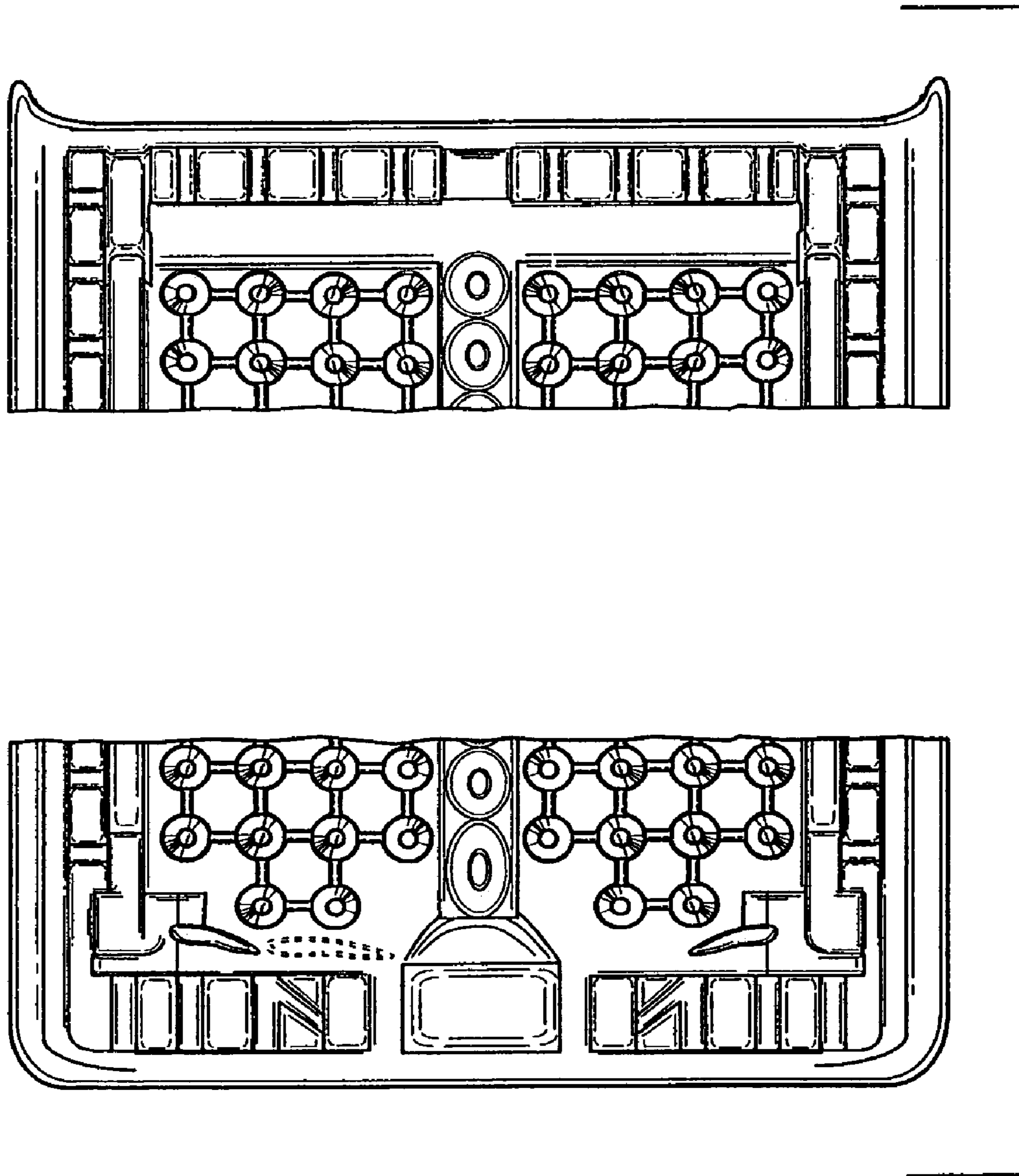

Fig. 5

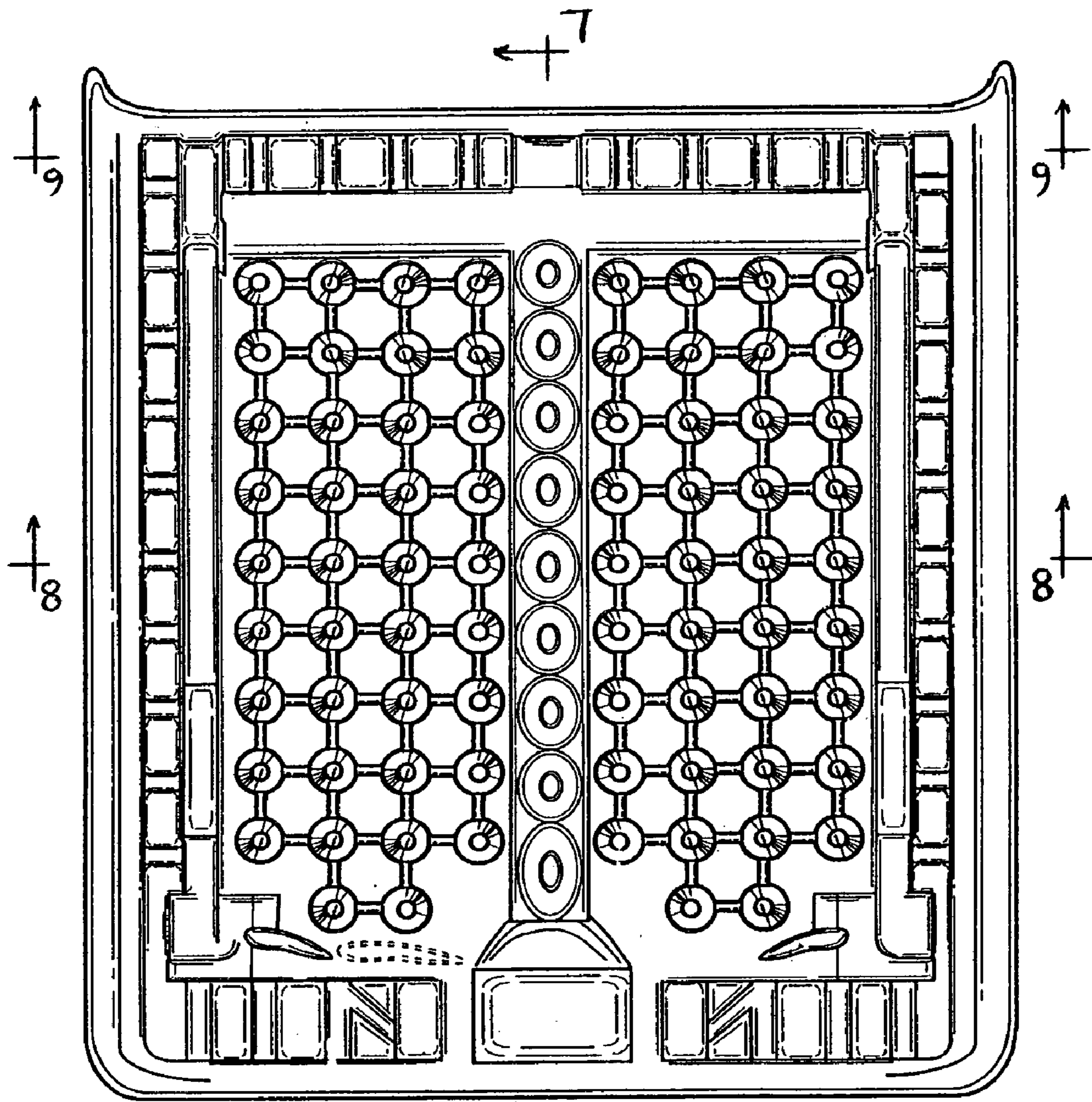

Fig. 6



Fig. 7



Fig. 8

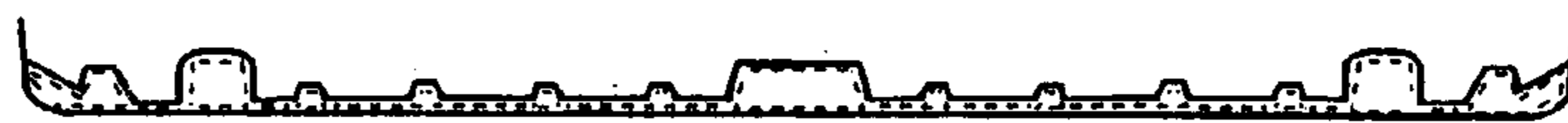

Fig. 9

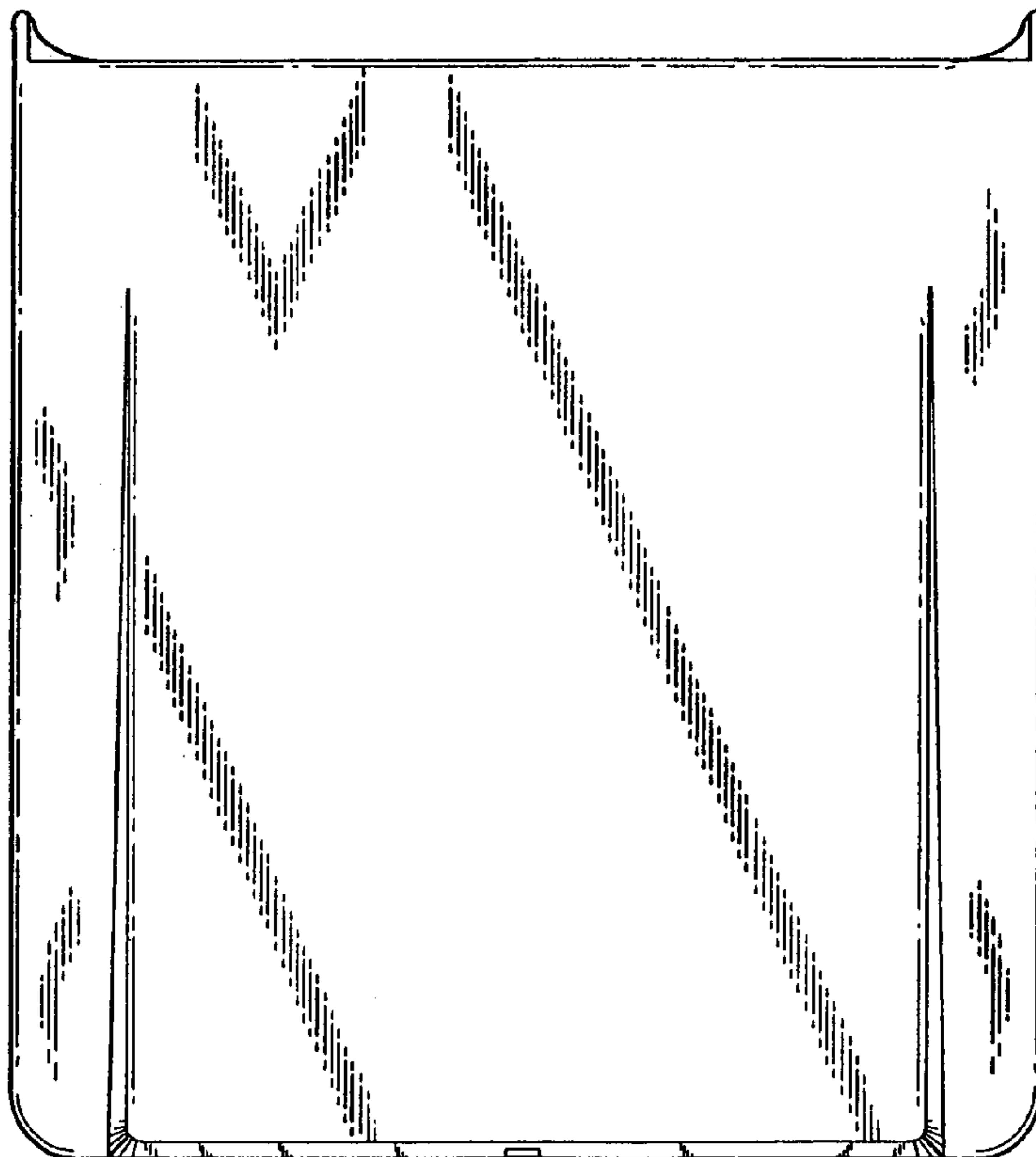

Fig. 10

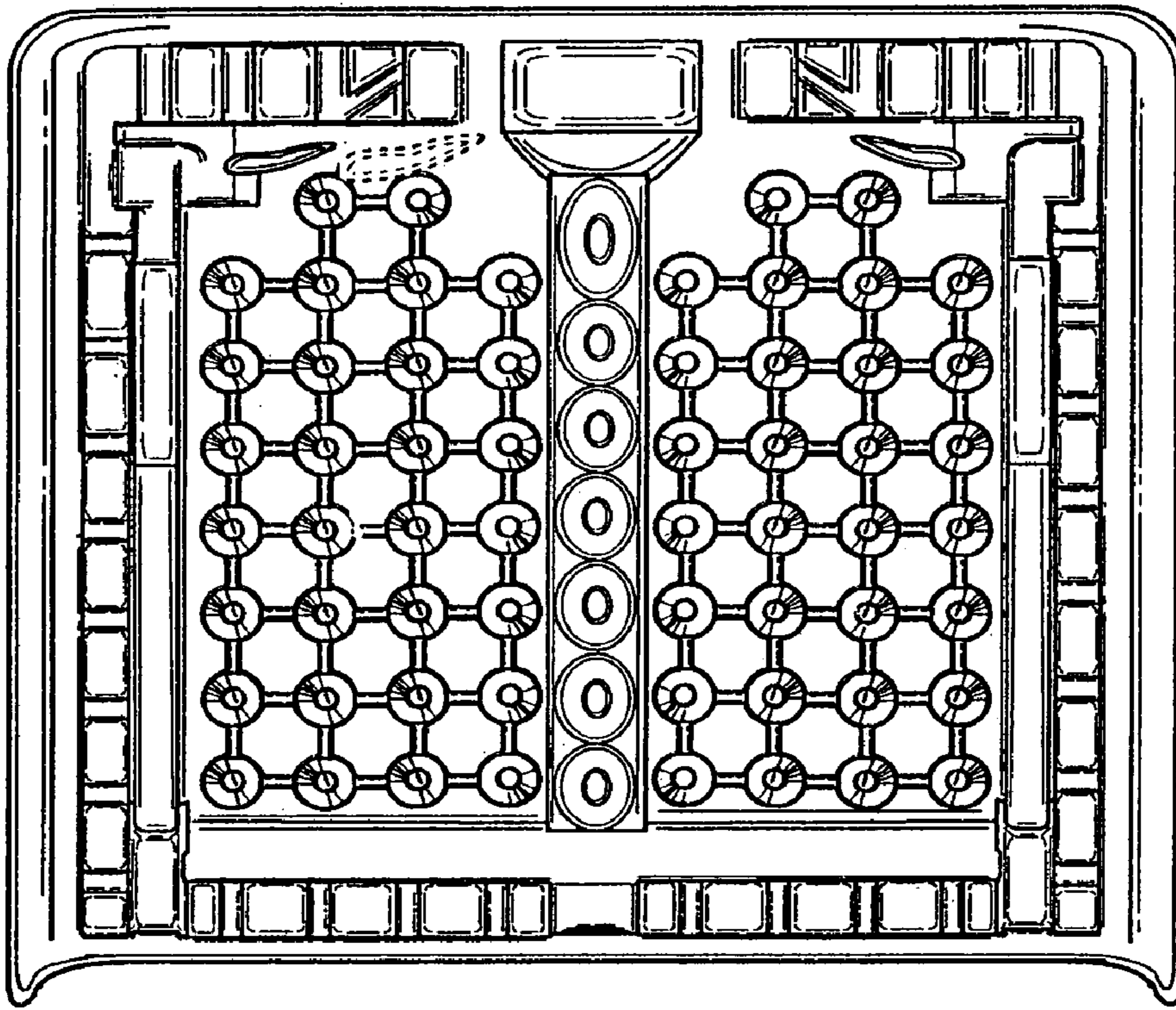

Fig. 11

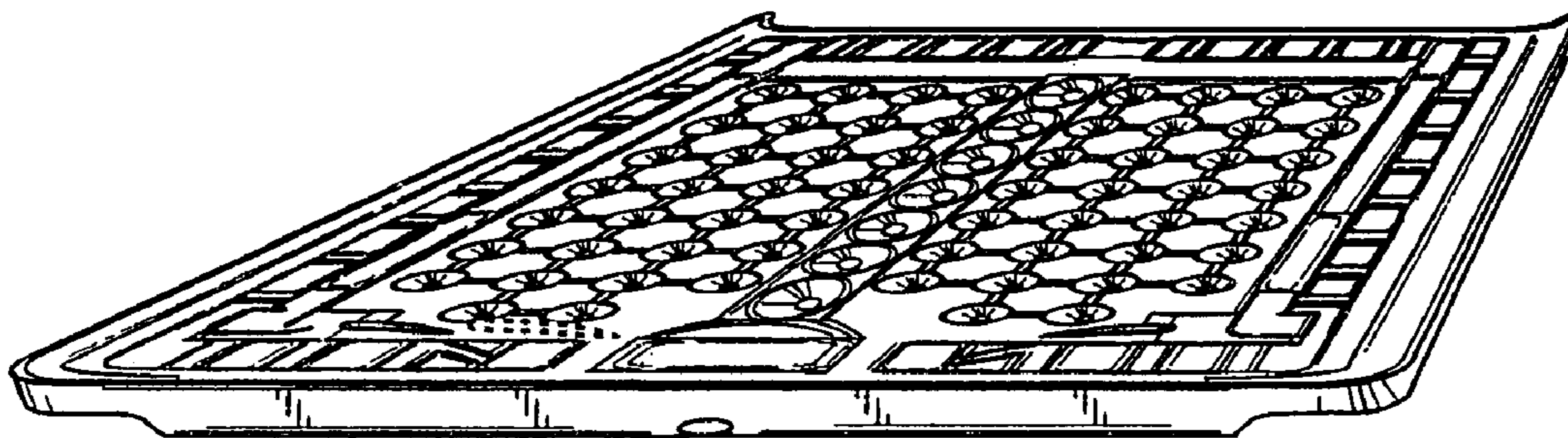

Fig. 12

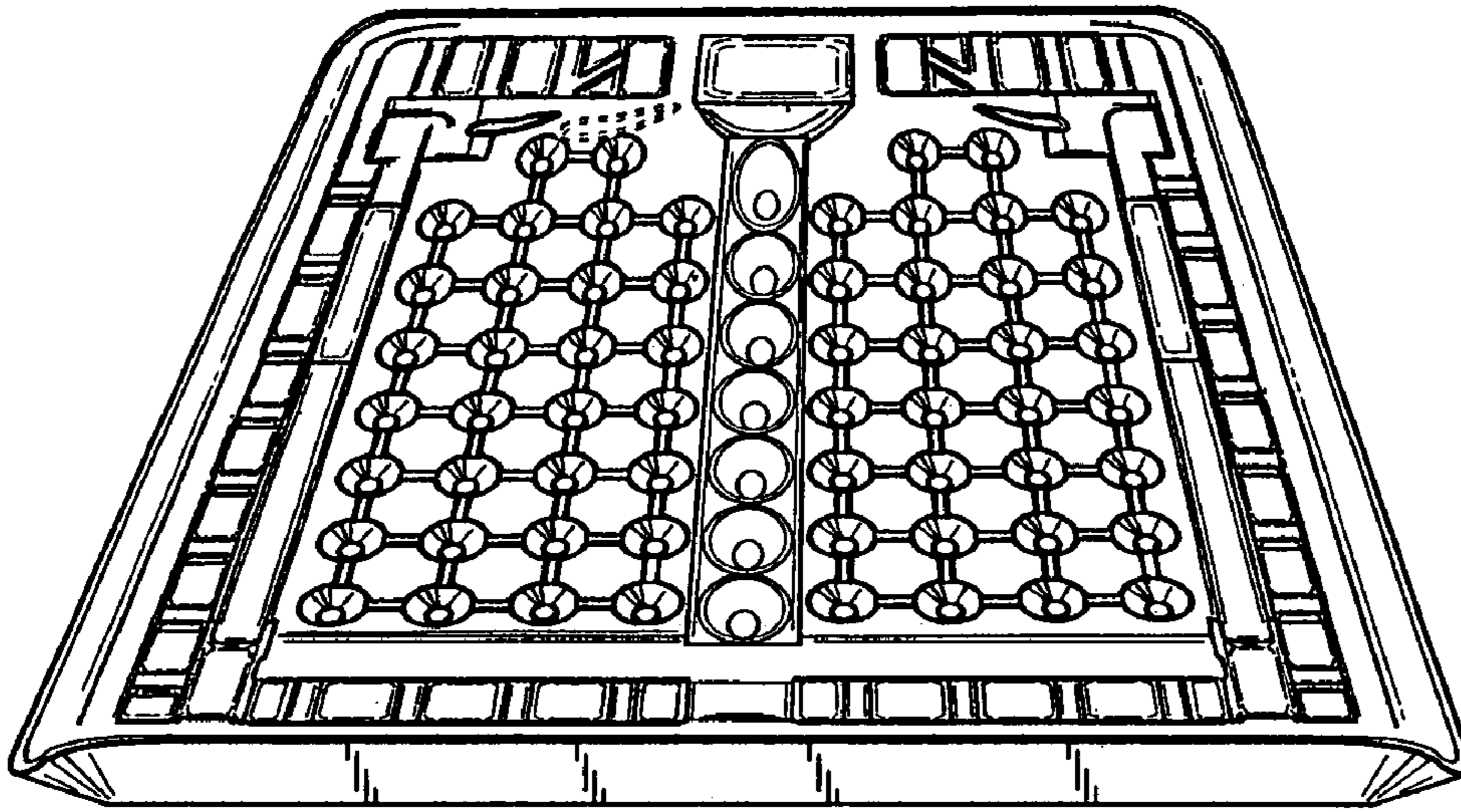

Fig. 13

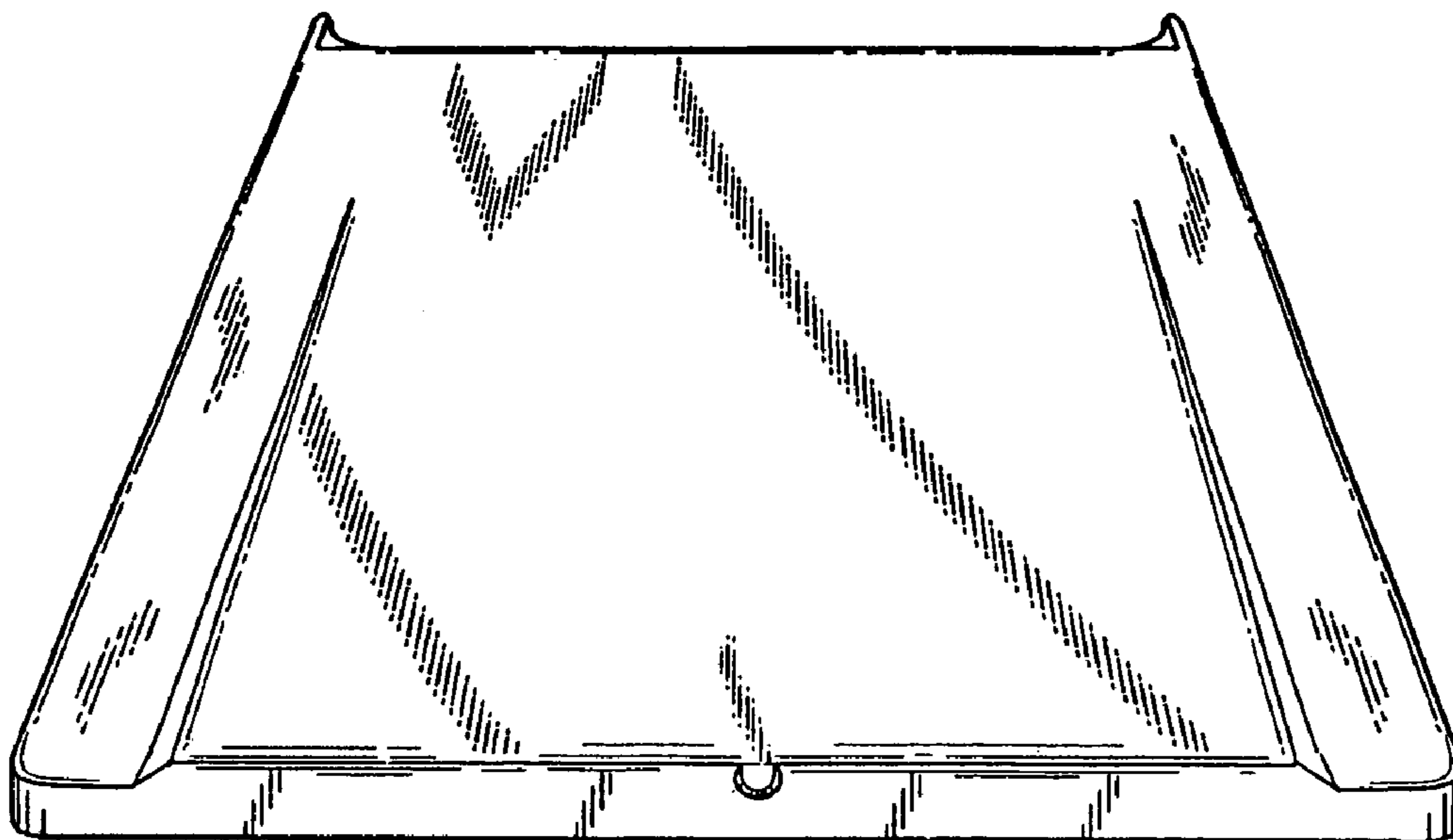

Fig. 14

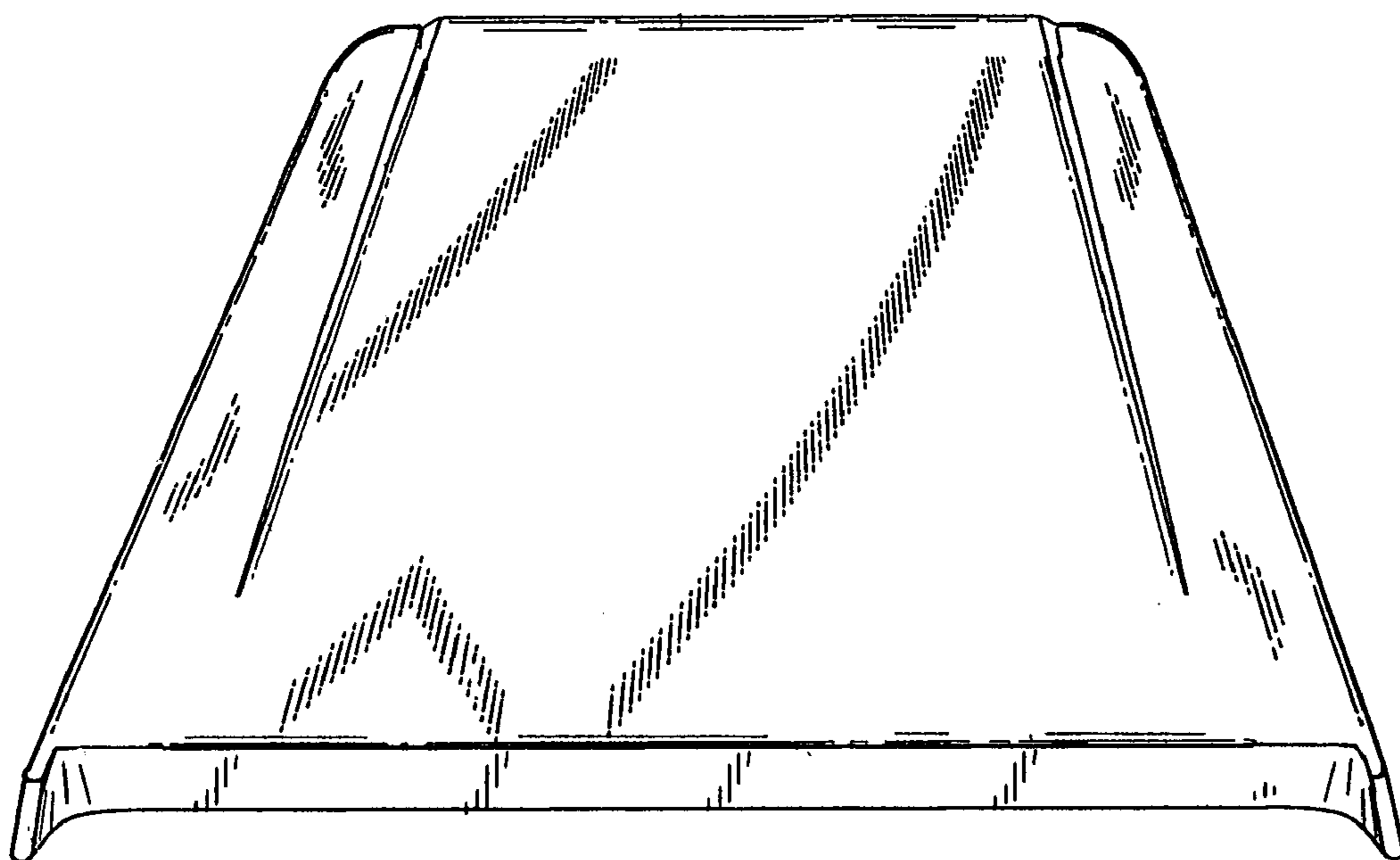

Fig. 15

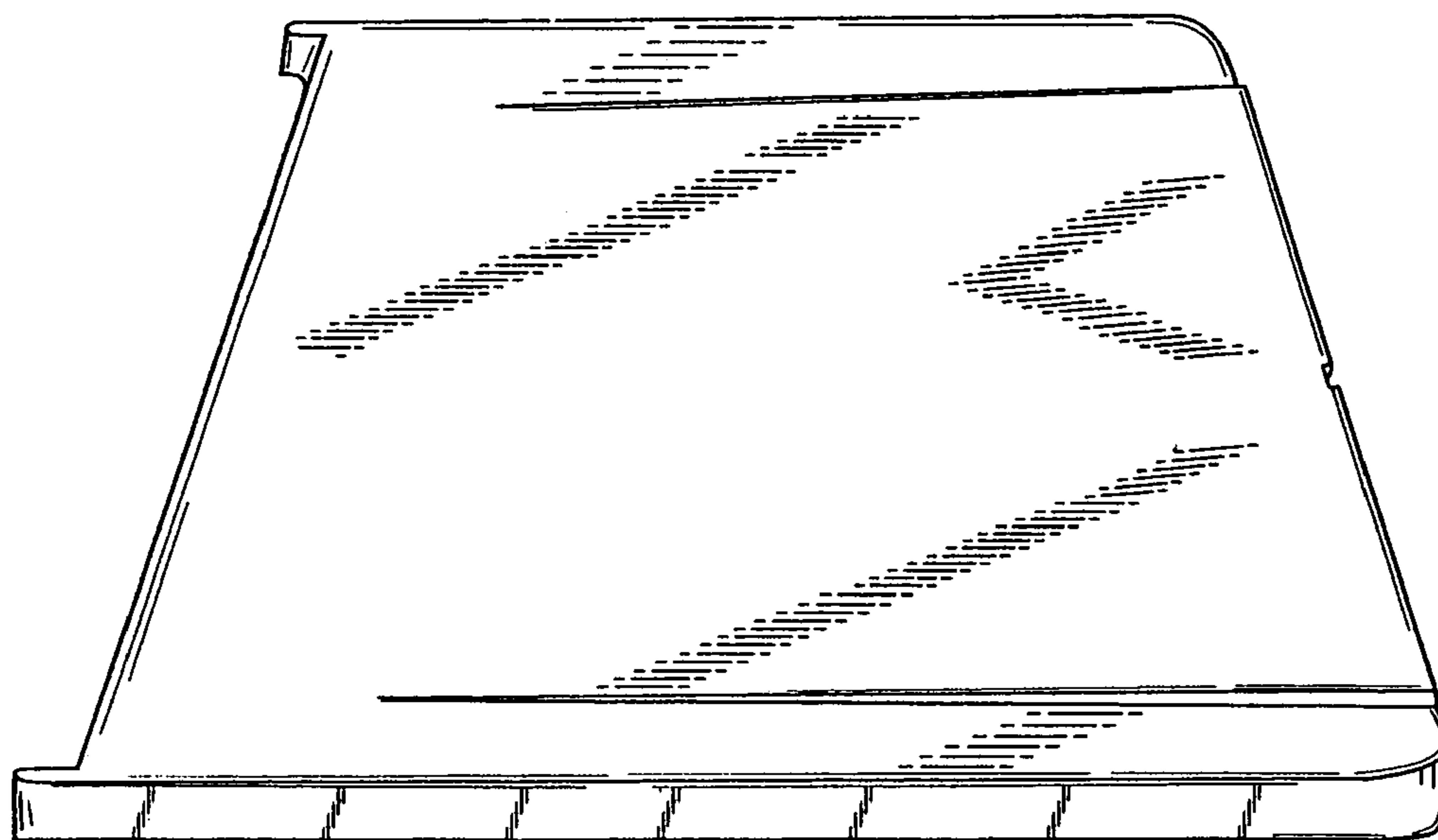

Fig. 16

Fig. 17

