

US00D574759S

(12) **United States Design Patent**  
**Thigpen**

(10) **Patent No.:** **US D574,759 S**

(45) **Date of Patent:** **\*\* Aug. 12, 2008**

(54) **HITCH COVER**

(76) Inventor: **James Thigpen**, 515 N. Fawn Ct.,  
Murfreesboro, TN (US) 37128

(\*\*) Term: **14 Years**

(21) Appl. No.: **29/287,174**

(22) Filed: **Jul. 6, 2007**

(51) **LOC (8) Cl.** ..... **12-16**

(52) **U.S. Cl.** ..... **D12/162**

(58) **Field of Classification Search** ..... D12/106,  
D12/115, 116, 161, 162, 199; 280/402, 403,  
280/404, 405.1, 405.2, 407, 407.1, 416.2,  
280/455.1, 491.5, 186, 433, 434, 438 R; D29/102,  
D29/104, 105, 115, 315, 356, 780; D26/31,  
D26/36

See application file for complete search history.

(56) **References Cited**

**U.S. PATENT DOCUMENTS**

D359,018 S	6/1995	Thigpen	
D385,662 S *	10/1997	Paglucci et al. ....	D29/105
D401,193 S *	11/1998	Julian .....	D12/162
D519,424 S *	4/2006	Fisher .....	D12/162
D519,801 S *	5/2006	Lee .....	D8/38

\* cited by examiner

*Primary Examiner*—Louis S Zarfaz

*Assistant Examiner*—Michael A Pratt

(74) *Attorney, Agent, or Firm*—Richard C. Litman

(57) **CLAIM**

The ornamental design for a hitch cover, as shown and described.

**DESCRIPTION**

FIG. 1 is a perspective view of a hitch cover showing my new design;

FIG. 2 is a front elevational view thereof;

FIG. 3 is a rear elevational view thereof;

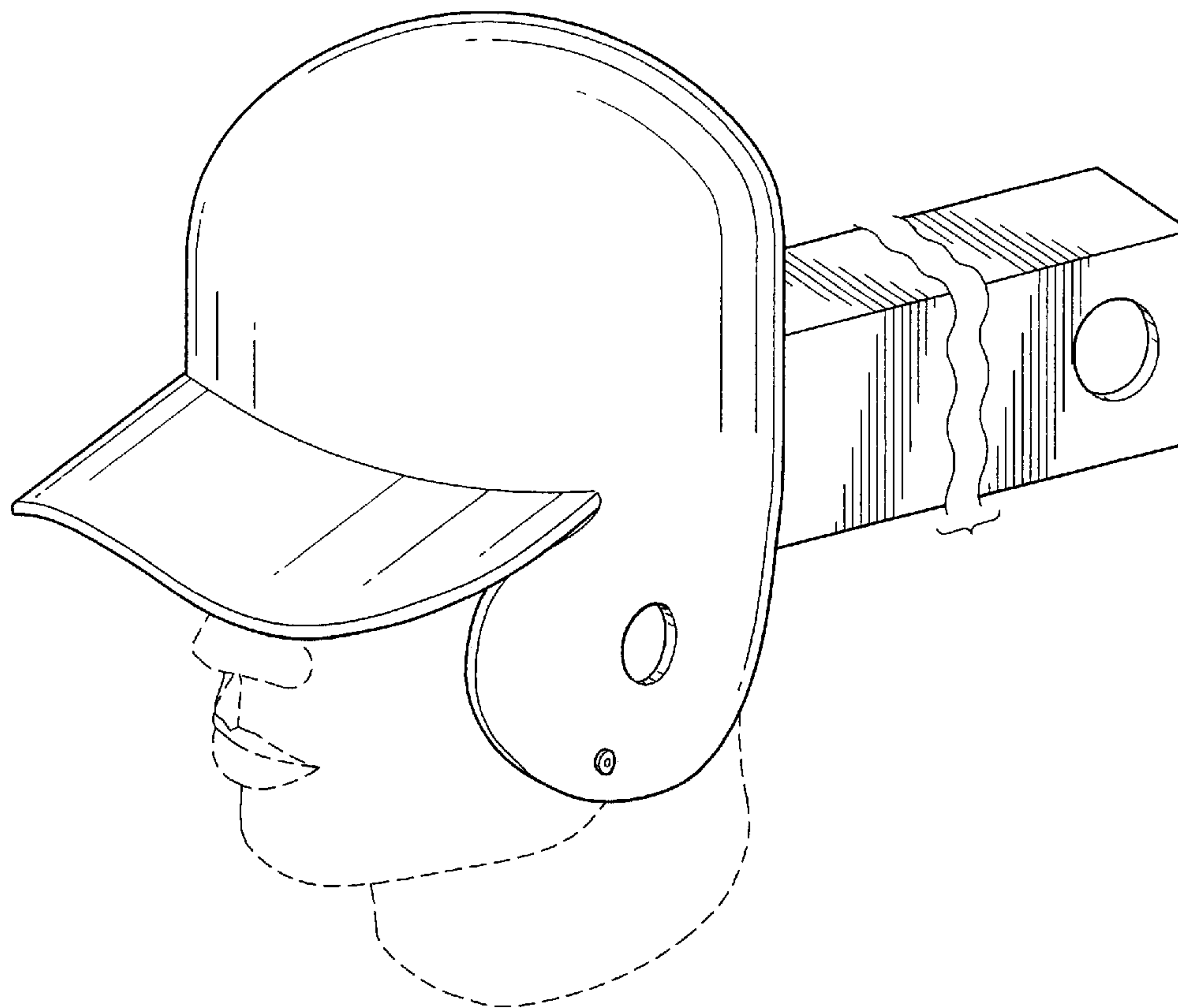
FIG. 4 is a right side elevational view with the left side being a mirror image thereof;

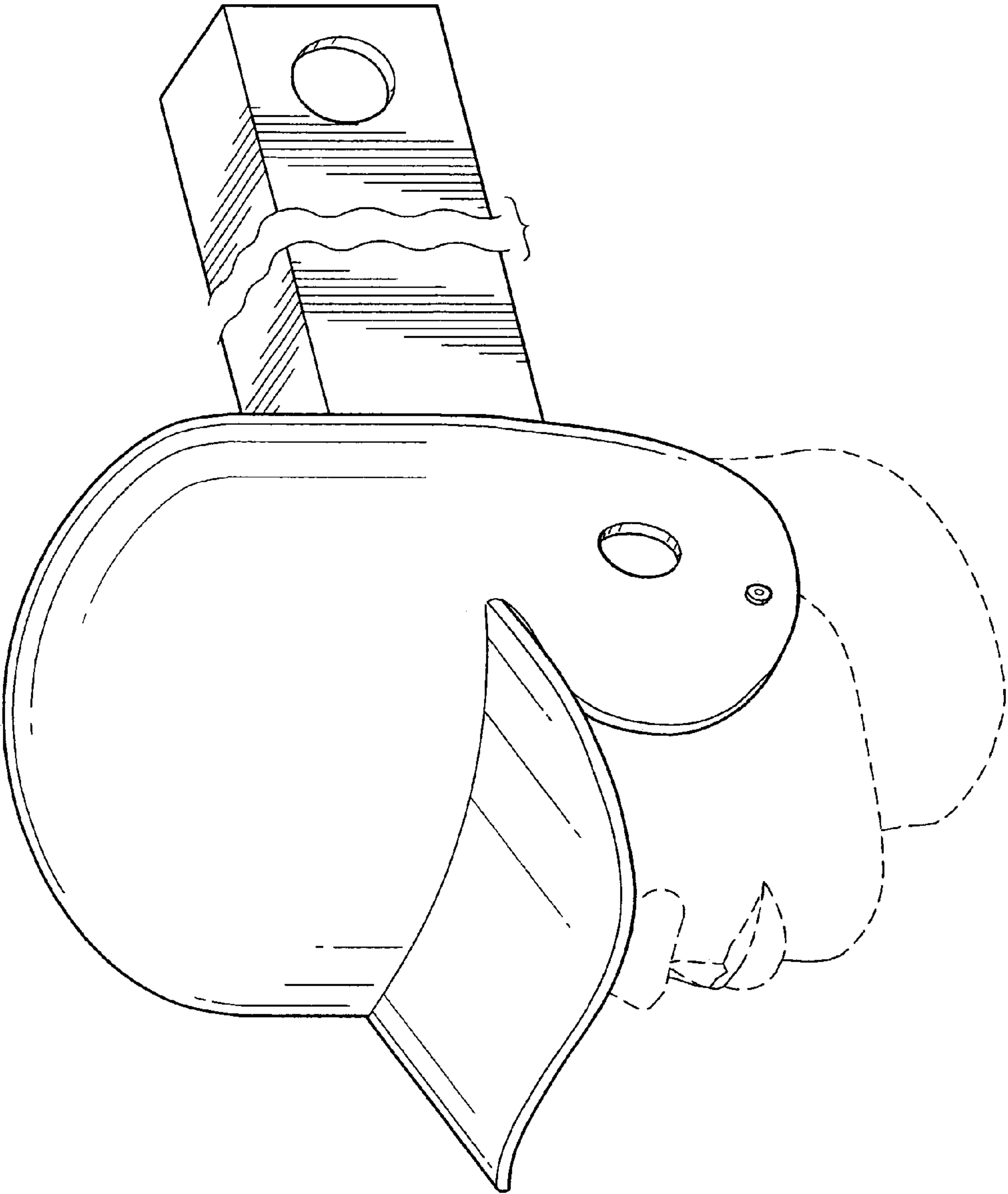
FIG. 5 is a top view thereof; and,

FIG. 6 is a bottom view thereof.

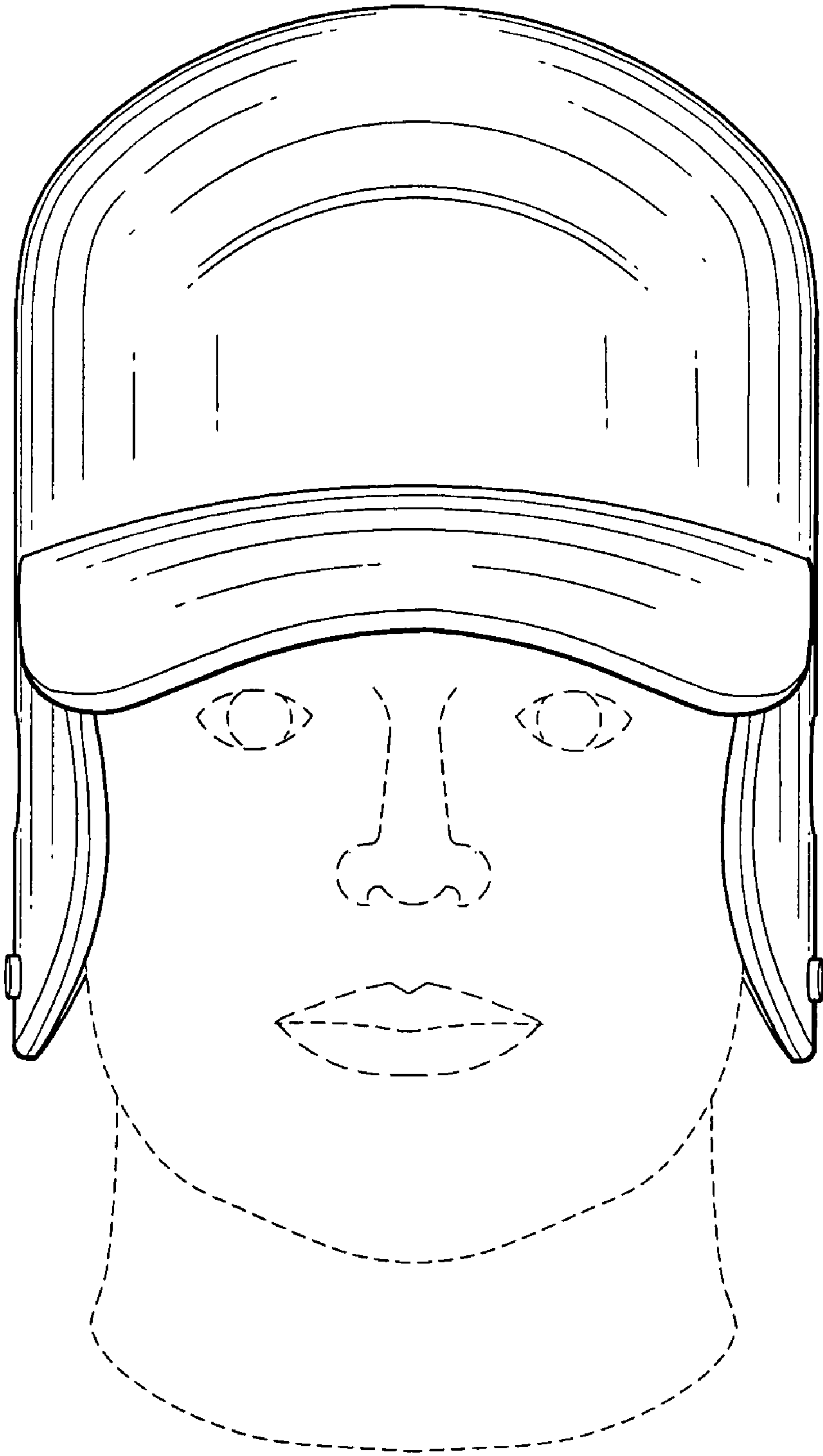
The broken line showing of the human face and neck in FIGS. 1–4 and 6 represents environmental structure and forms no part of the claimed design. The broken line showing of the helmet padding in FIG. 6 represents environmental structure and forms no part of the claimed design. The break lines in FIGS. 1 and 4–6 indicate indeterminate length.

**1 Claim, 6 Drawing Sheets**

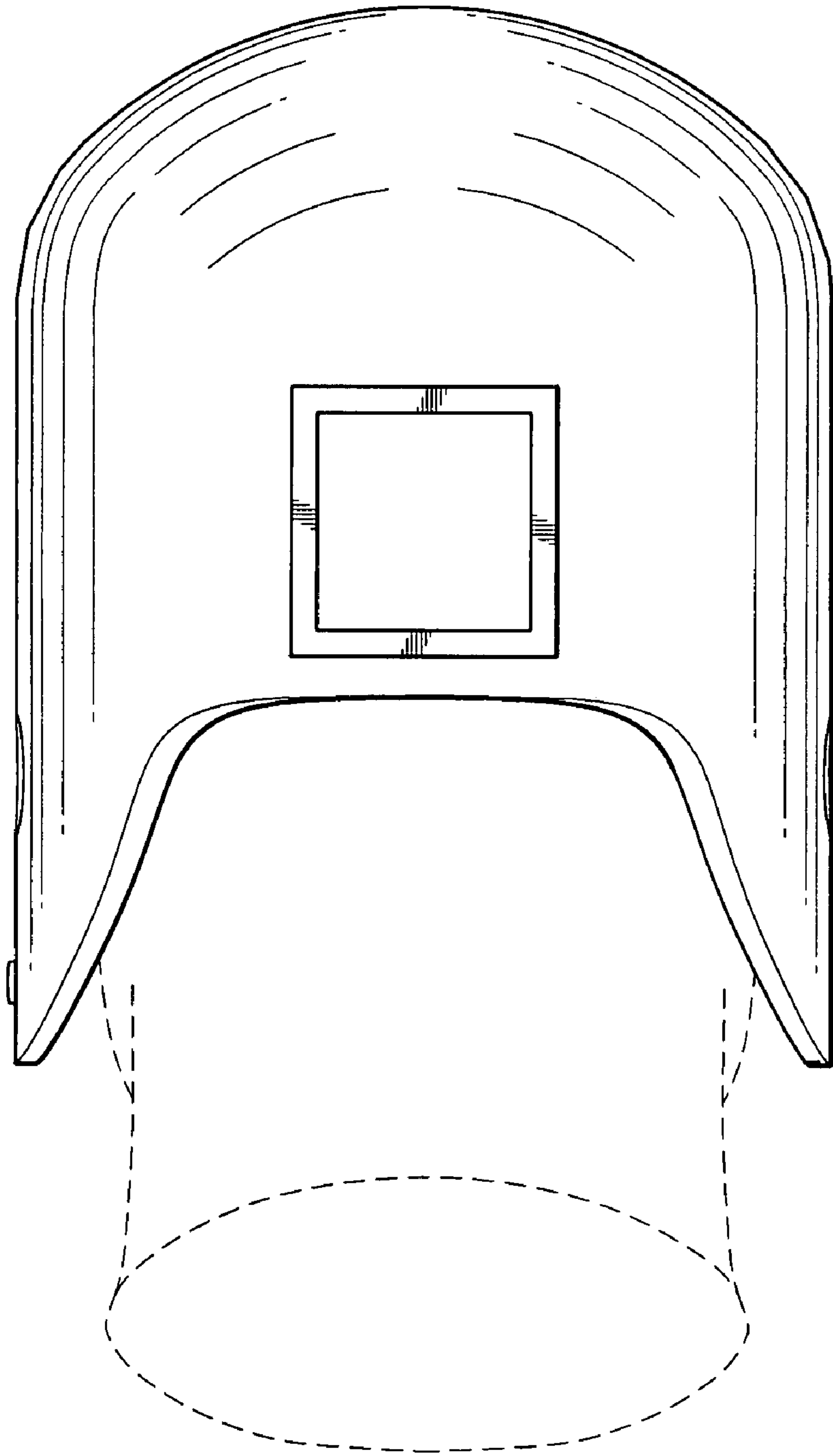




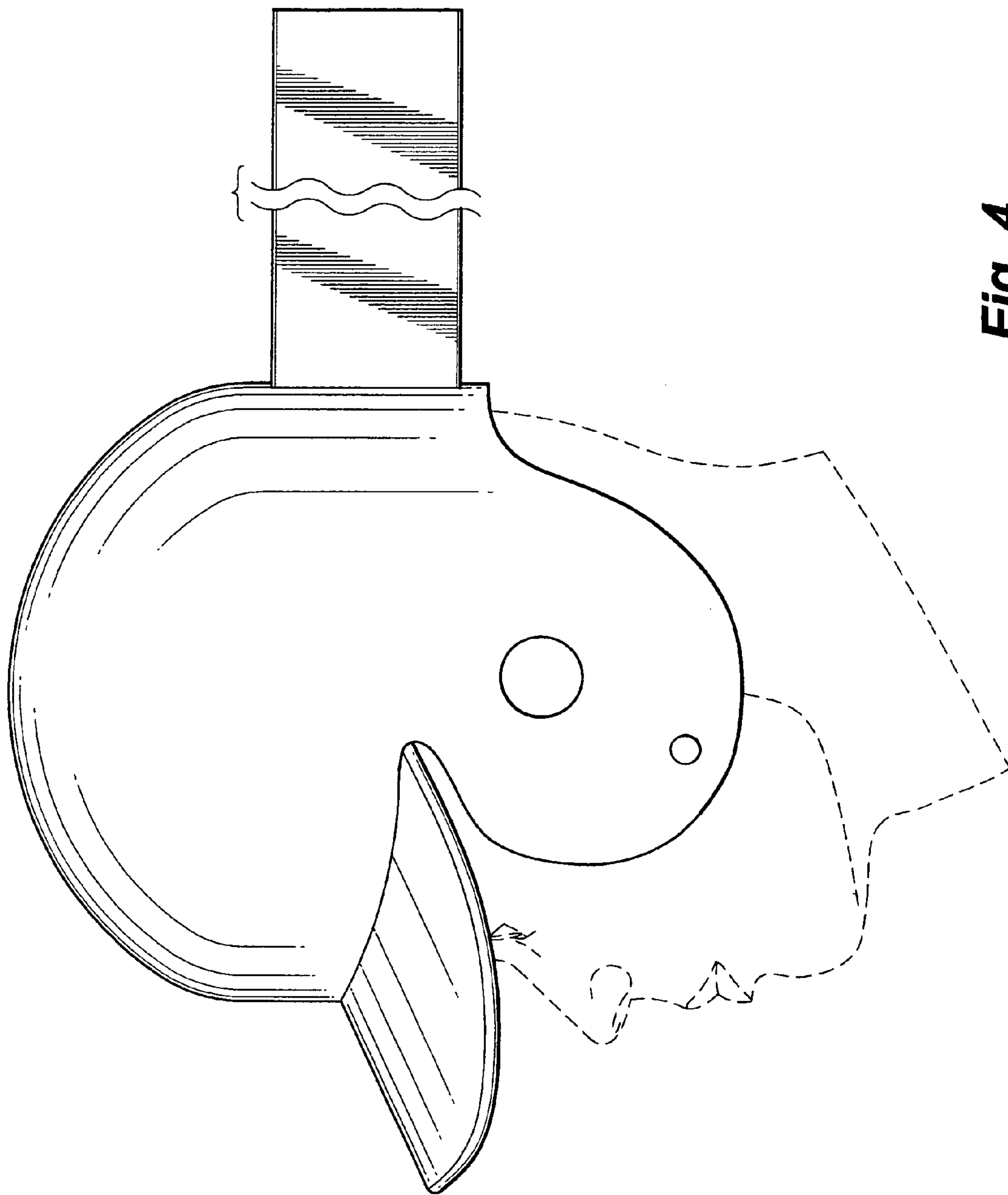
**Fig. 1**



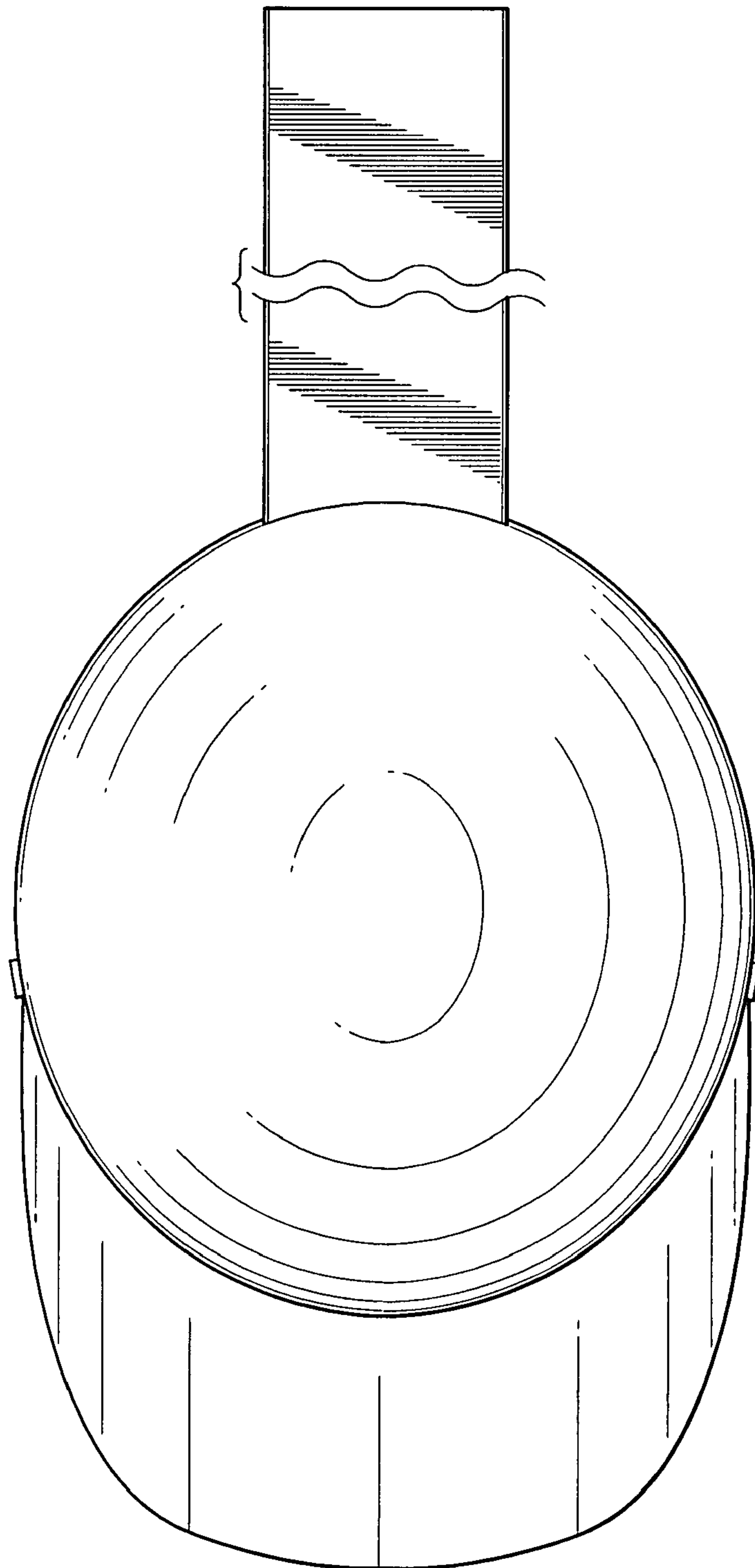
**Fig. 2**



**Fig. 3**

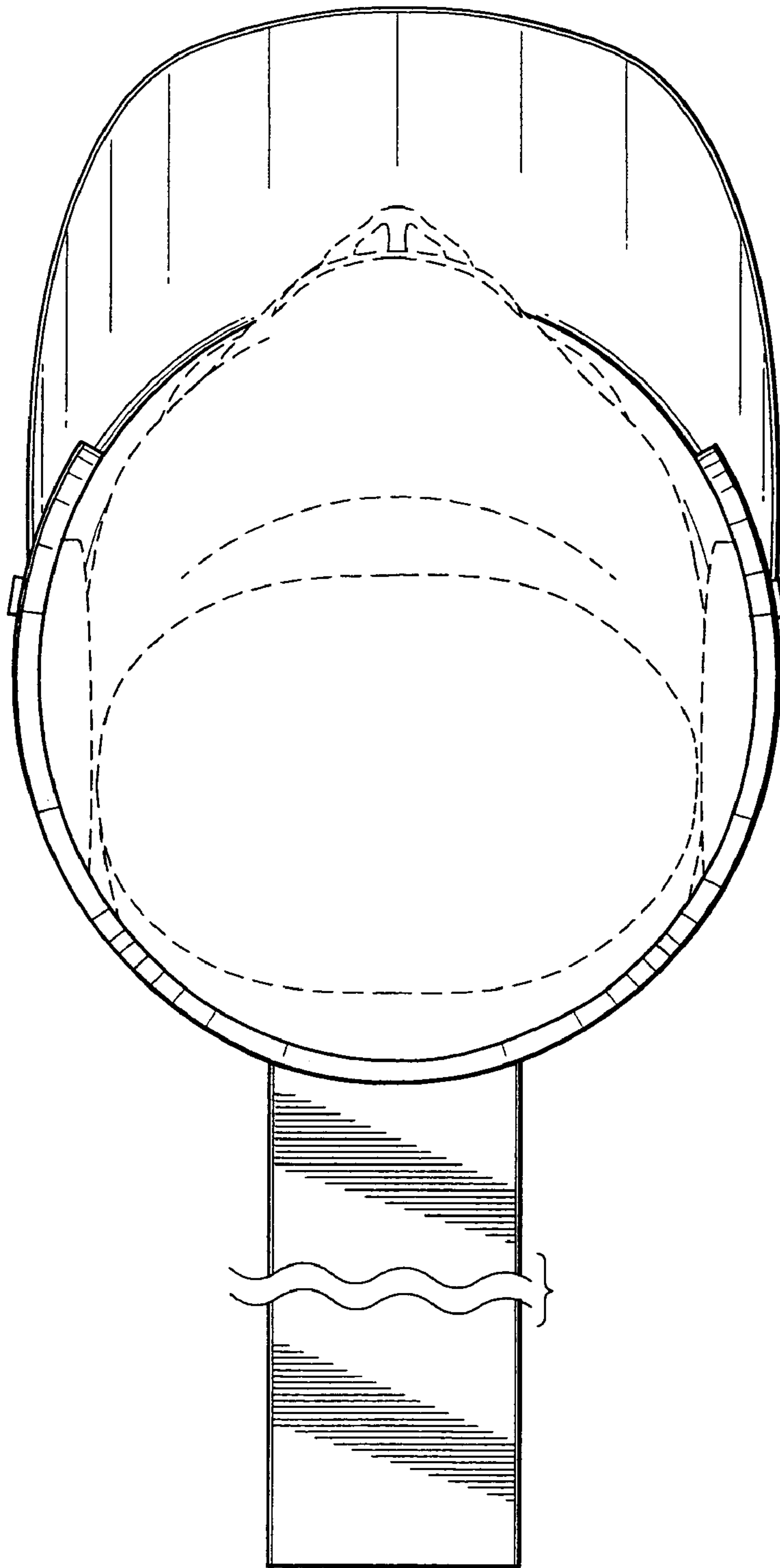


**Fig. 4**



**Fig. 5**





**Fig. 6**