



US00D574080S

(12) **United States Design Patent**  
**Segawa et al.**

(10) **Patent No.:** **US D574,080 S**  
(45) **Date of Patent:** **\*\* Jul. 29, 2008**

(54) **CAPSULE ENDOSCOPE STARTER**

(75) Inventors: **Hidetake Segawa**, Tokyo (JP);  
**Hirotooshi Amano**, Tokyo (JP)

(73) Assignees: **Olympus Medical Systems Corp.**,  
Tokyo (JP); **Olympus Imaging Corp.**,  
Tokyo (JP)

(\*\*) Term: **14 Years**

(21) Appl. No.: **29/255,741**

(22) Filed: **Mar. 9, 2006**

(30) **Foreign Application Priority Data**

Sep. 9, 2005 (JP) ..... 2005-026264

(51) **LOC (8) Cl.** ..... **24-02**

(52) **U.S. Cl.** ..... **D24/133; D24/138**

(58) **Field of Classification Search** ..... D24/133,  
D24/137, 138, 187, 186, 107, 108; 600/300,  
600/139, 302, 7, 109-112, 131, 103, 160  
See application file for complete search history.

(56) **References Cited**

**U.S. PATENT DOCUMENTS**

6,689,056	B1 *	2/2004	Kilcoyne et al.	600/300
2001/0051766	A1 *	12/2001	Gazdzinski	600/309
2003/0023150	A1 *	1/2003	Yokoi et al.	600/300
2007/0260175	A1 *	11/2007	Segawa et al.	604/79
2008/0027267	A1 *	1/2008	Segawa	600/7

2008/0033257	A1 *	2/2008	Yokoi et al.	600/300
2008/0039675	A1 *	2/2008	Segawa	600/7
2008/0045789	A1 *	2/2008	Sawachi	600/111

\* cited by examiner

*Primary Examiner*—Ian Simmons

*Assistant Examiner*—Carissa C Fitts

(74) *Attorney, Agent, or Firm*—Scully, Scott, Murphy & Presser, P.C.

(57) **CLAIM**

The ornamental design for a capsule endoscope starter, as shown and described.

**DESCRIPTION**

An article to which my new design is applied is a starter of a medical swallowable endoscope (the so-called capsule endoscope) used in a wireless in vivo information acquiring system for collecting in vivo information. The starter includes a permanent magnet. The capsule endoscope, when loaded into the starter, is applied with magnet force, thereby starting.

FIG. 1 is a front view of a capsule endoscope starter showing my new design;

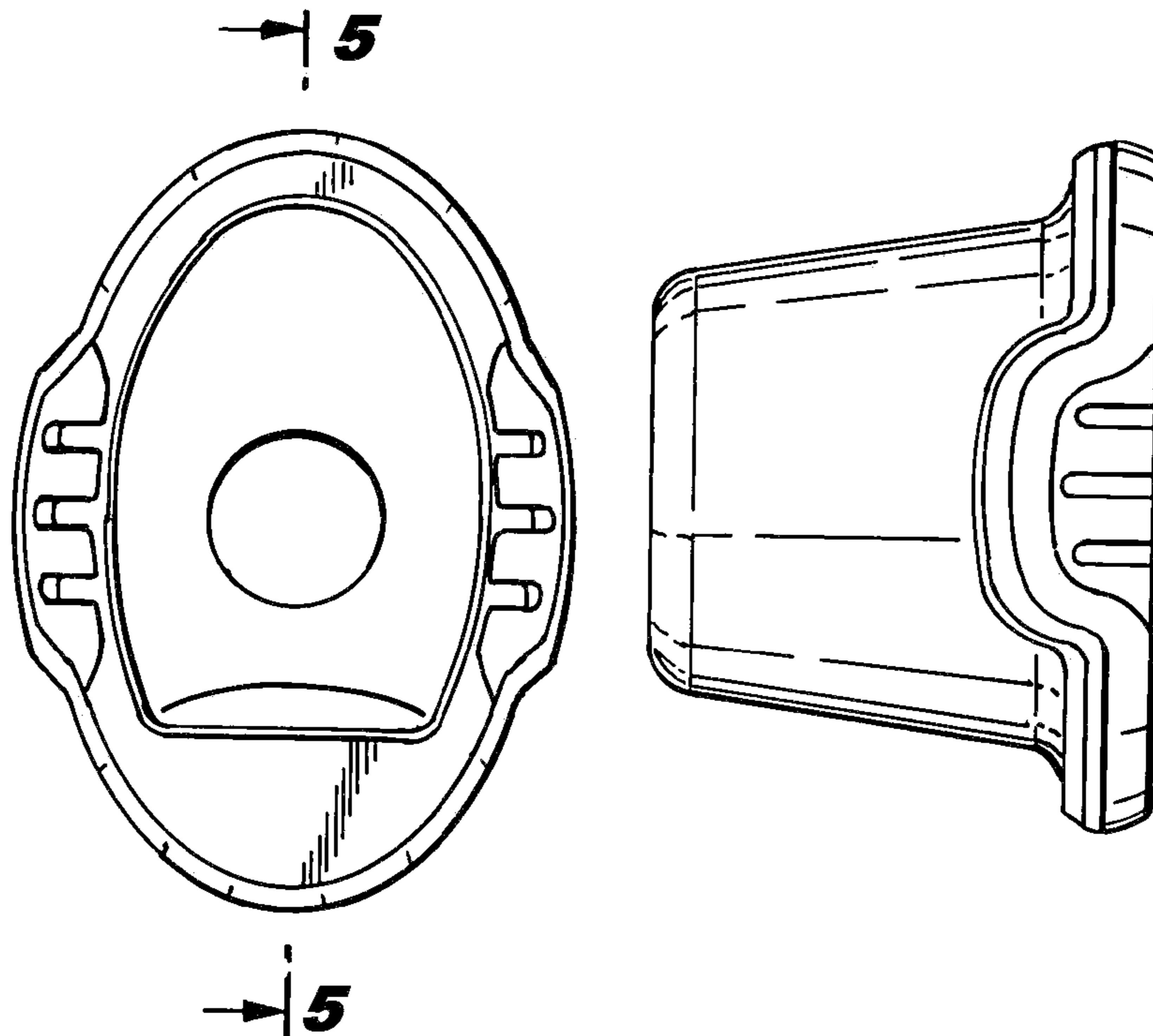
FIG. 2 is a rear view thereof;

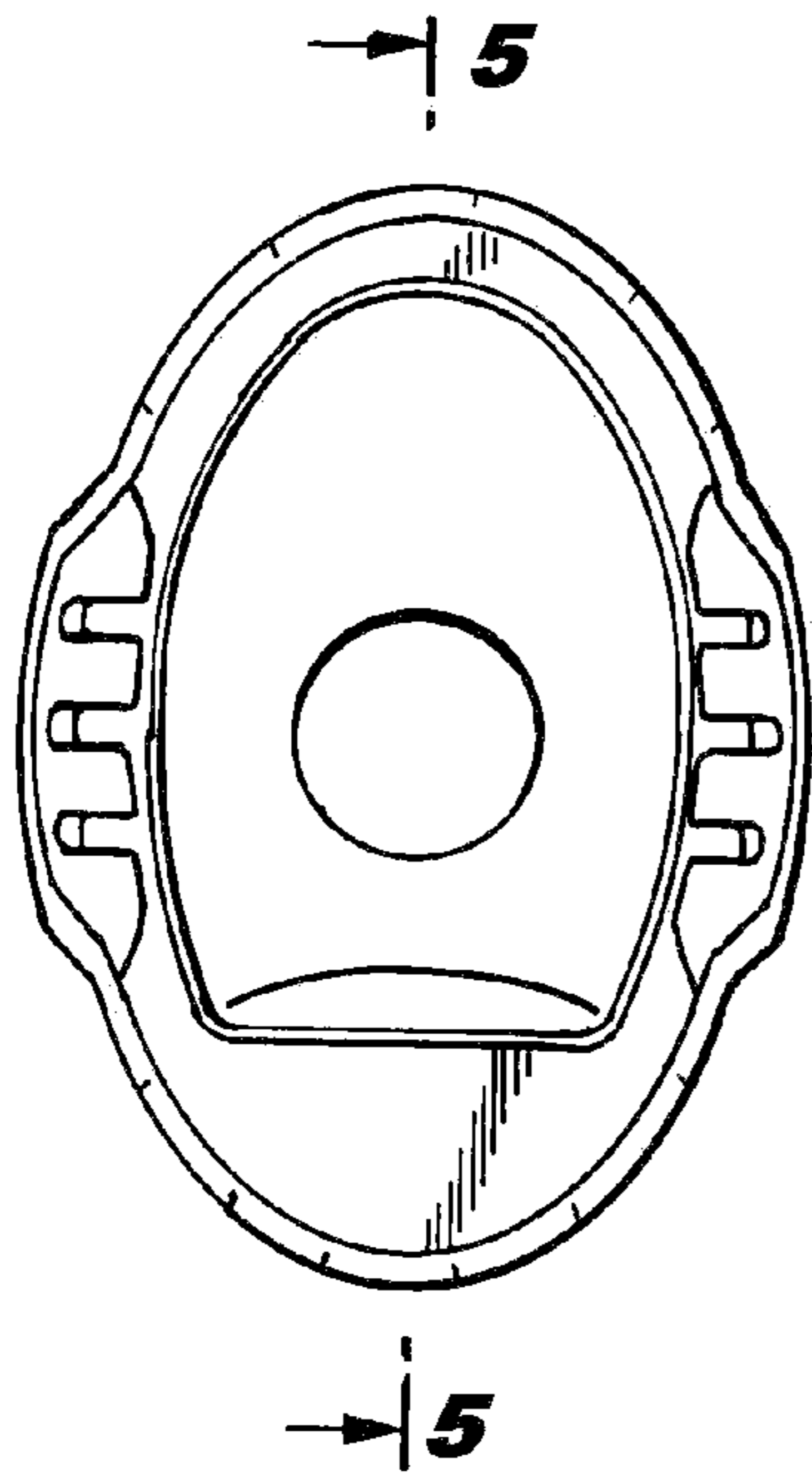
FIG. 3 is a plan view thereof;

FIG. 4 is a left side view thereof; and,

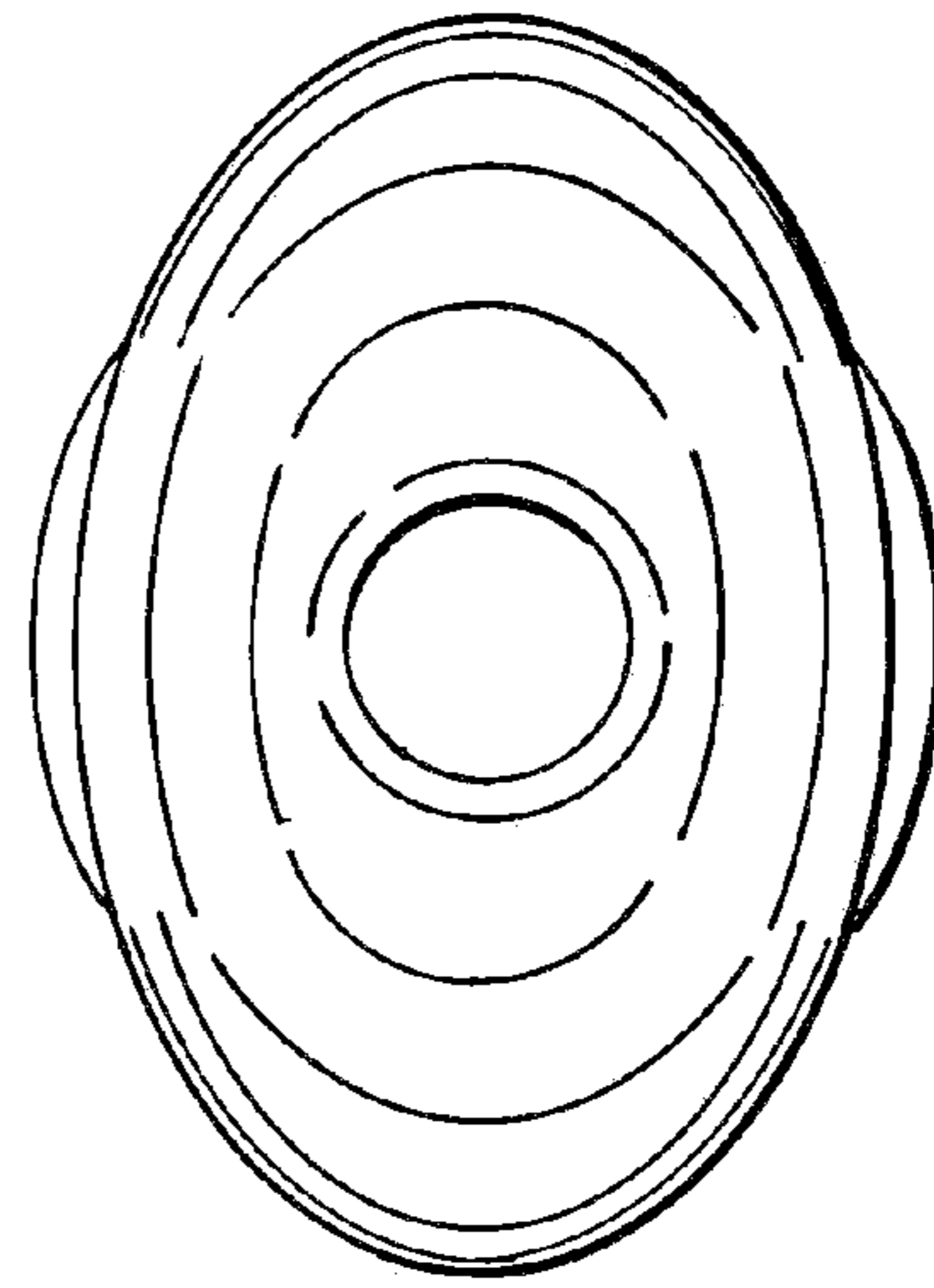
FIG. 5 is a cross sectional view taken along line A—A of FIG. 1.

**1 Claim, 1 Drawing Sheet**

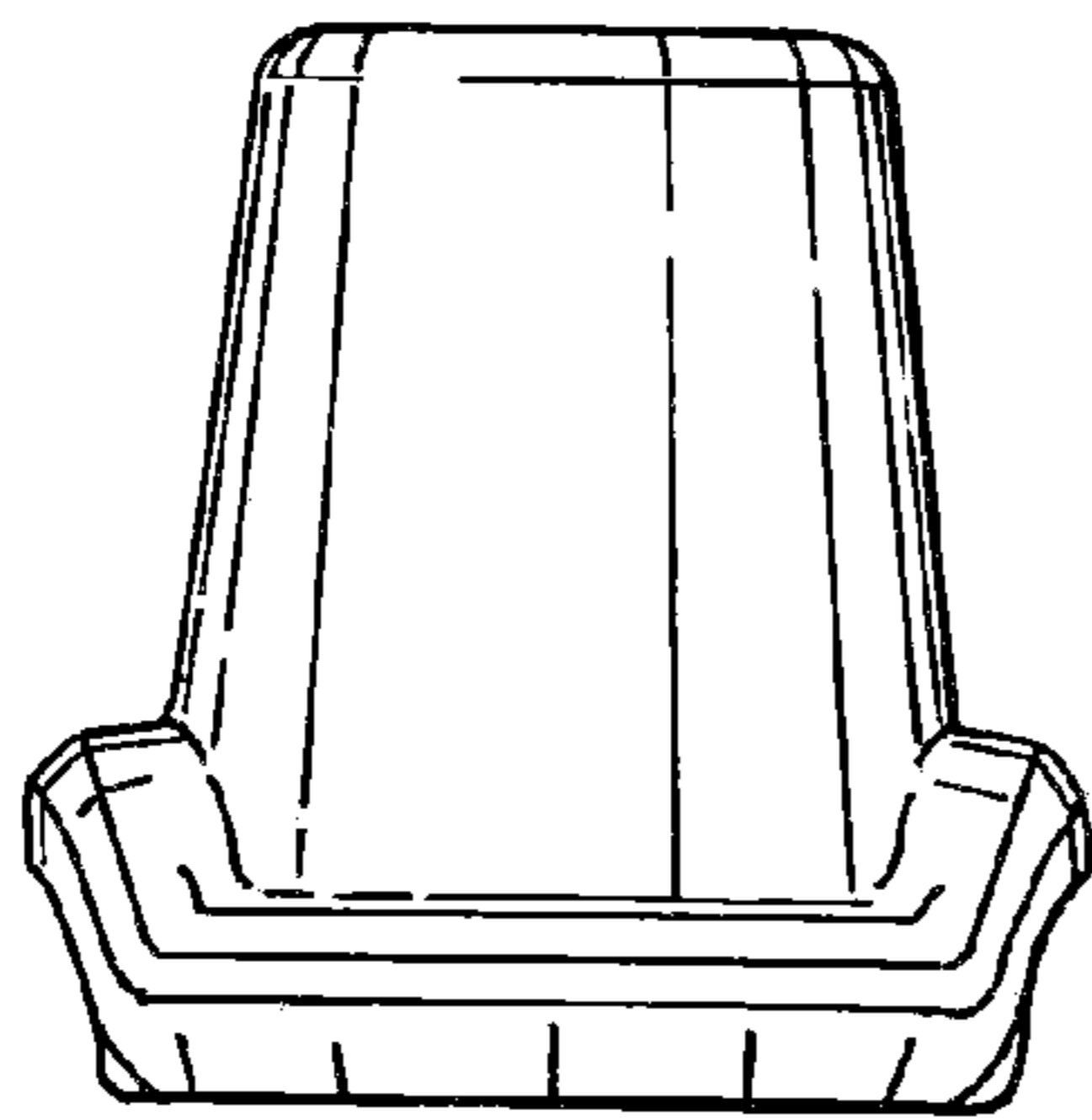




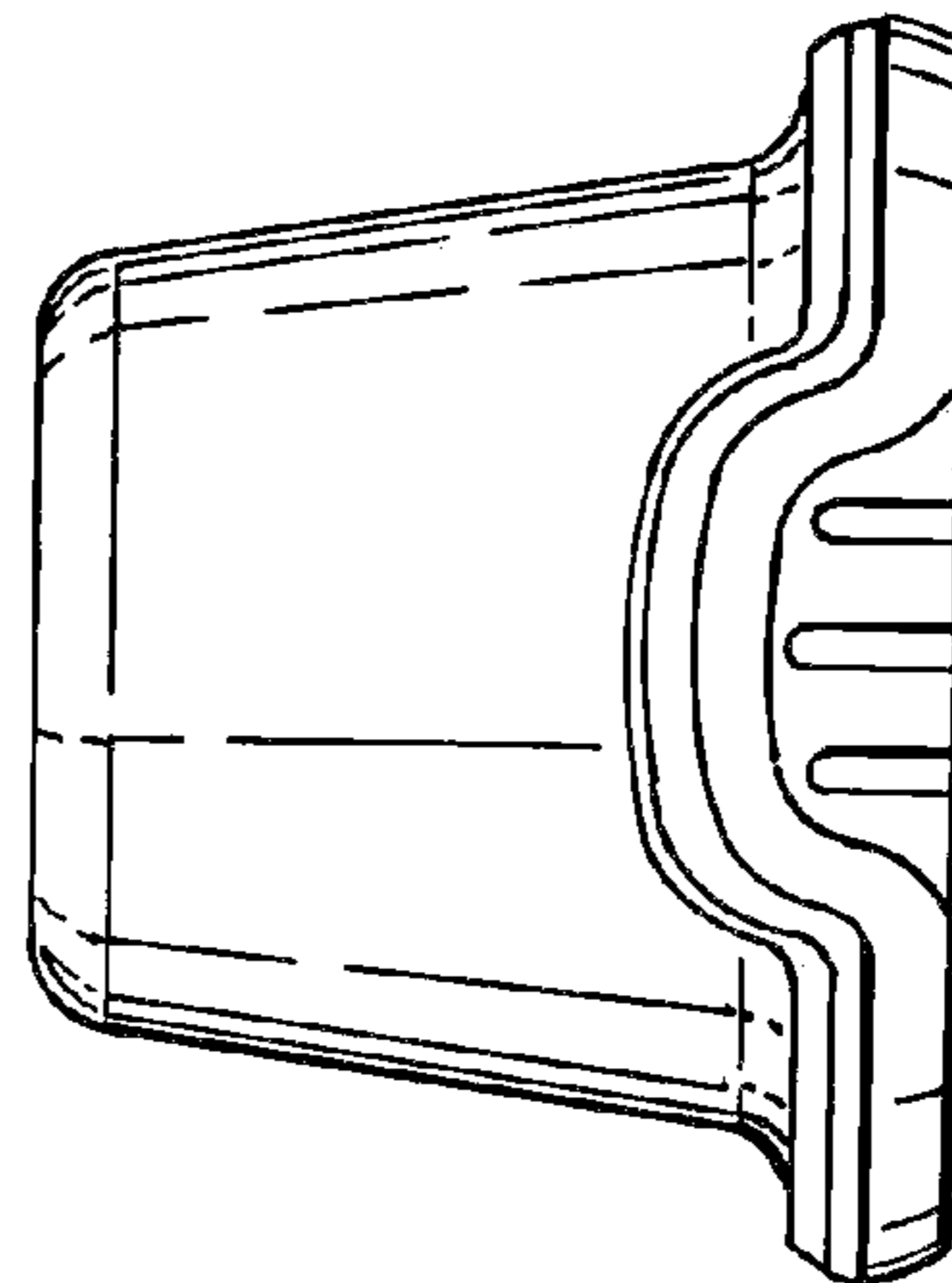
**Fig. 1**



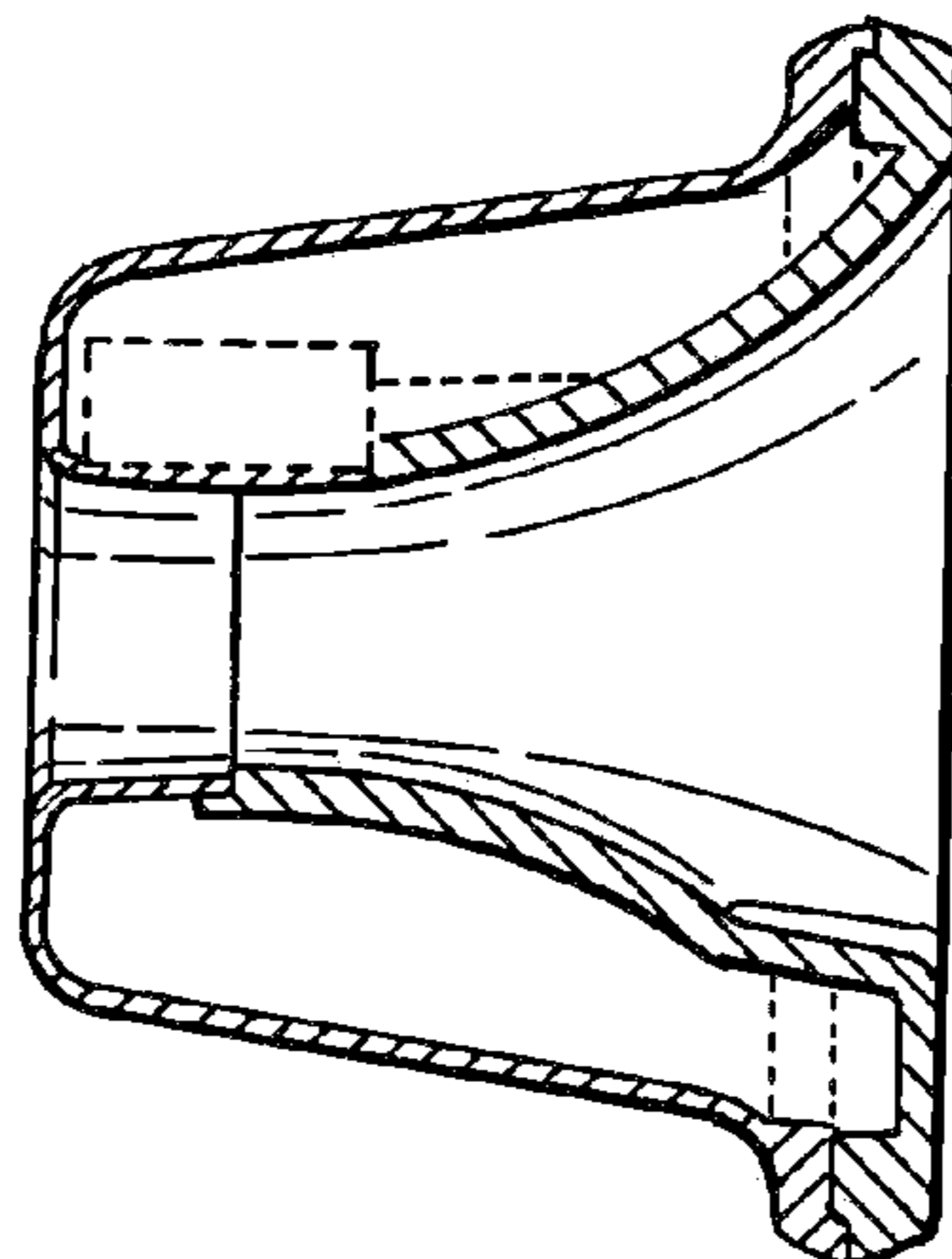
**Fig. 2**



**Fig. 3**



**Fig. 4**



**Fig. 5**