



US00D573802S

(12) **United States Design Patent**  
**Mills**

(10) **Patent No.:** **US D573,802 S**  
(45) **Date of Patent:** **\*\* Jul. 29, 2008**

(54) **MOTORCYCLE BACKREST**

(76) Inventor: **Clarence H. Mills**, 169 McGee St.,  
Russellville, AL (US) 35654

(\*\*) Term: **14 Years**

(21) Appl. No.: **29/277,745**

(22) Filed: **Mar. 8, 2007**

(51) **LOC (8) Cl.** ..... **12-11**

(52) **U.S. Cl.** ..... **D6/354**

(58) **Field of Classification Search** ..... D6/354,  
D6/596, 601, 606; D12/110, 114, 119; 180/219;  
297/195.1, 196-215, 215.1-215.16, 312,  
297/337, 230.1, 410, 230.11-230.14, 232,  
297/233, 243; D2/719; 5/630, 632, 633,  
5/635, 417-420, 652, 653, 656, 657.5; 280/288.4,  
280/304.4

See application file for complete search history.

(56) **References Cited**

**U.S. PATENT DOCUMENTS**

3,940,166 A \* 2/1976 Smithea ..... 297/215.11  
D341,509 S \* 11/1993 Evans ..... D6/502  
6,761,401 B1 \* 7/2004 McGlynn ..... 297/215.12

\* cited by examiner

*Primary Examiner*—Cathron Brooks

*Assistant Examiner*—Linda Brooks

(74) *Attorney, Agent, or Firm*—Lanier Ford Shaver & Payne  
P.C.; J. Mark Bledsoe

(57) **CLAIM**

I claim the ornamental design for a motorcycle backrest, as  
shown and described.

**DESCRIPTION**

FIG. 1 is a front perspective view of a motorcycle backrest,  
showing my new design.

FIG. 2 is a back perspective view thereof.

FIG. 3 is a top view thereof.

FIG. 4 is a left side view thereof.

FIG. 5 is a bottom view thereof.

FIG. 6 is a right side view thereof

FIG. 7 is a front view thereof; and,

FIG. 8 is a back view thereof.

The fastening elements on the left and right sides of the  
motorcycle backrest are shown in different positions due to  
their flexible nature.

The broken lines shown in the drawing illustrate stitching.

**1 Claim, 4 Drawing Sheets**

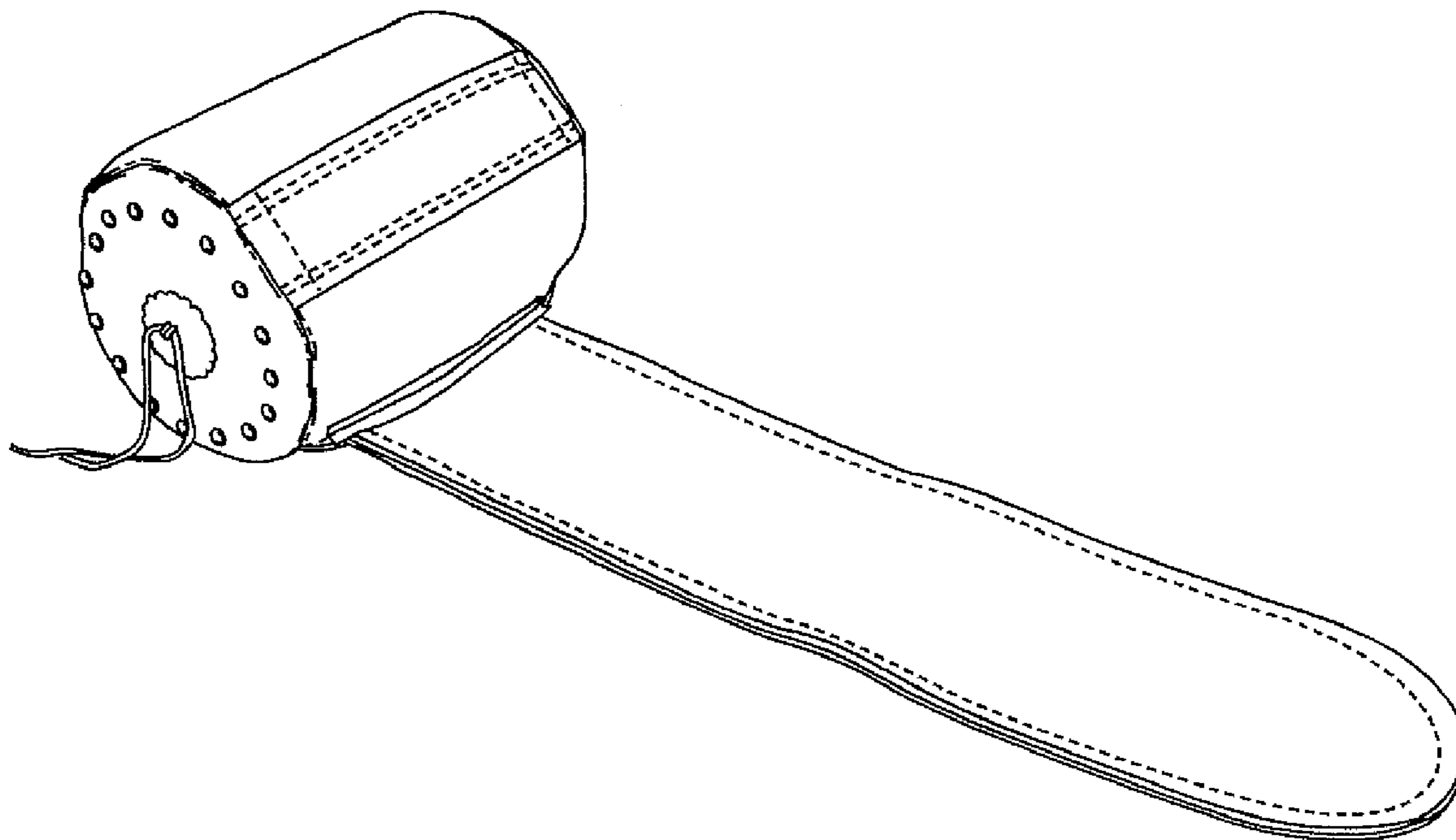

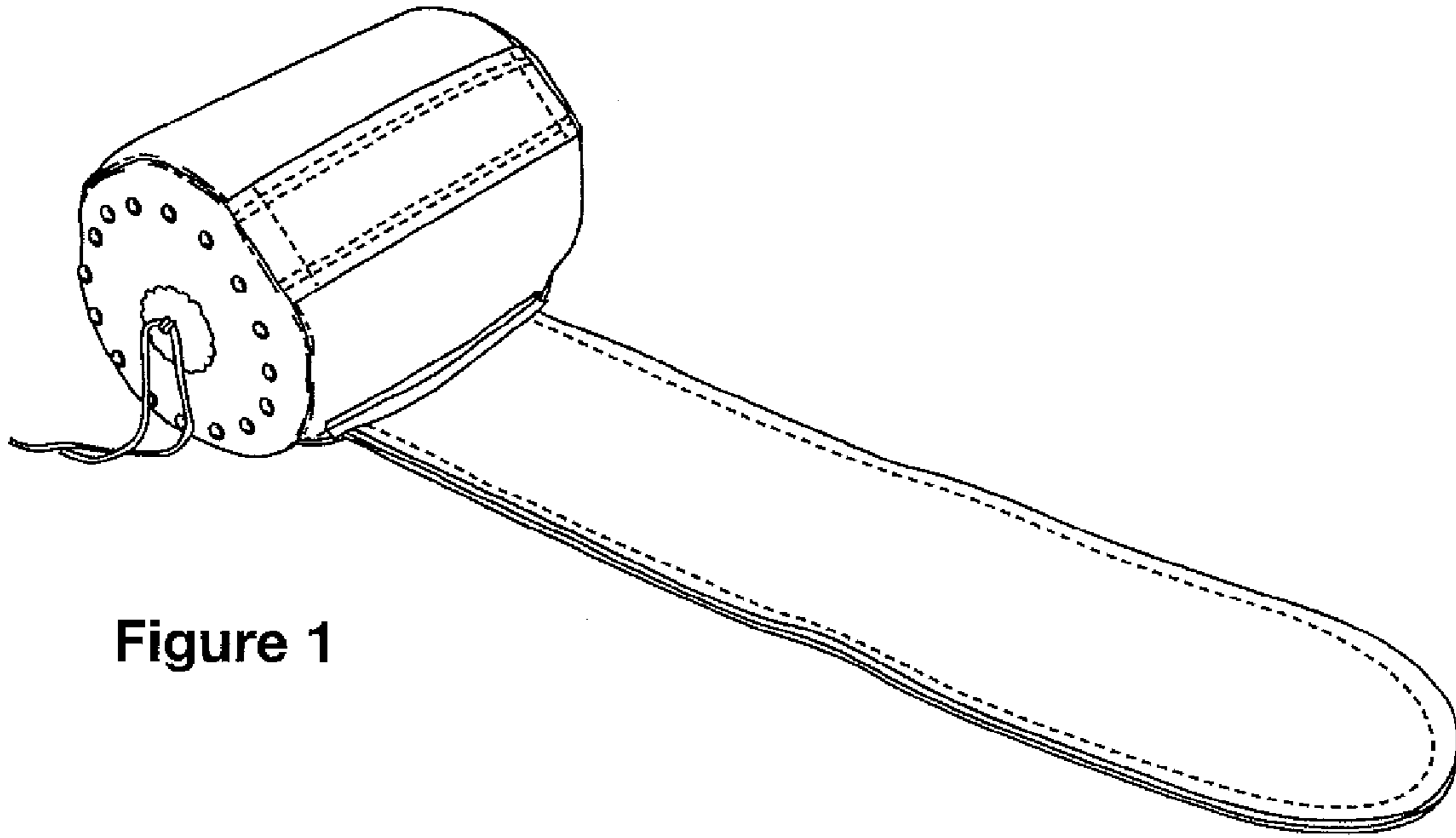

Figure 1

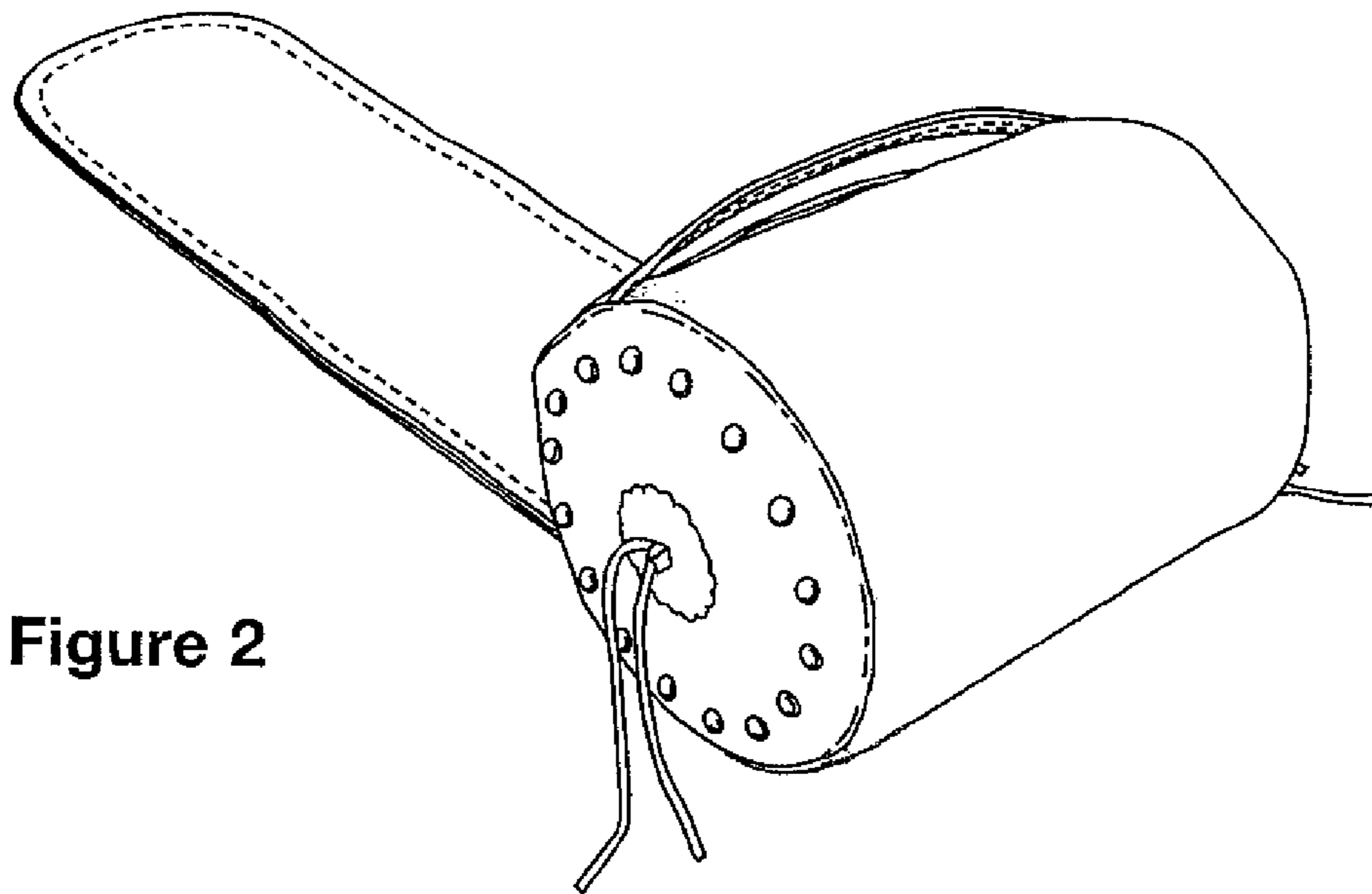

Figure 2

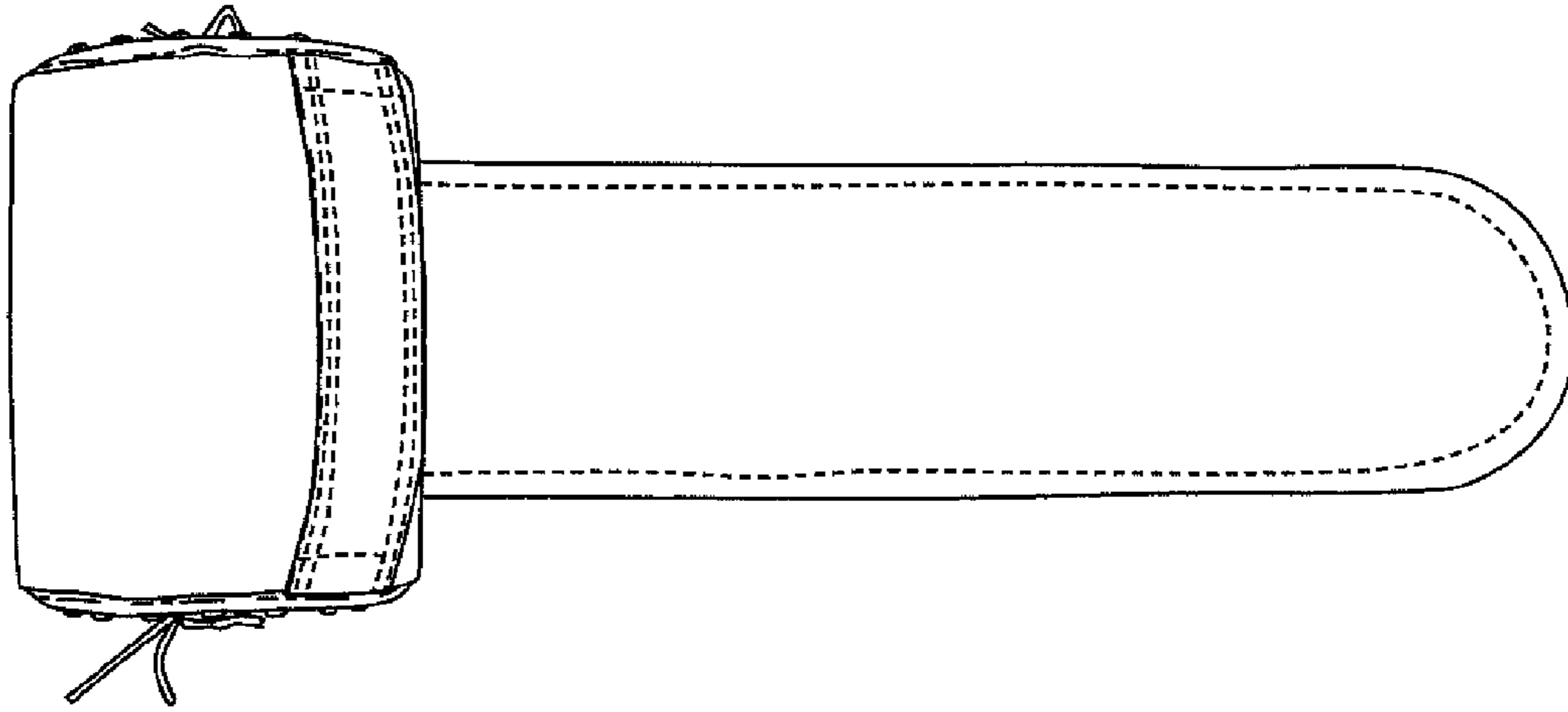

Figure 3

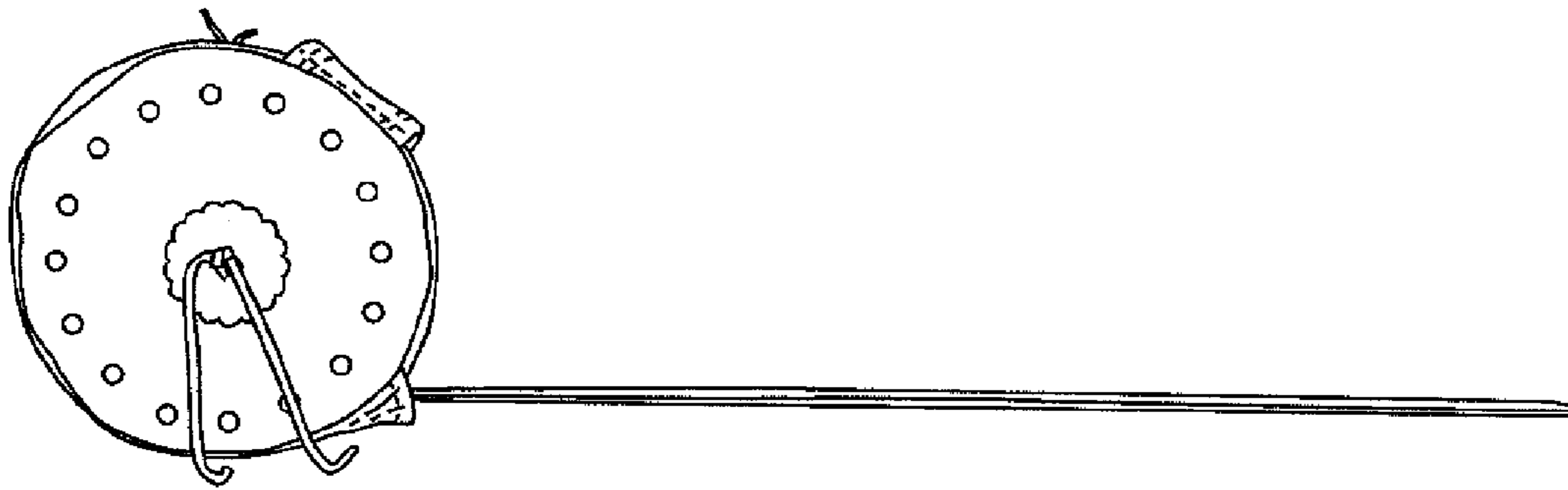

Figure 4

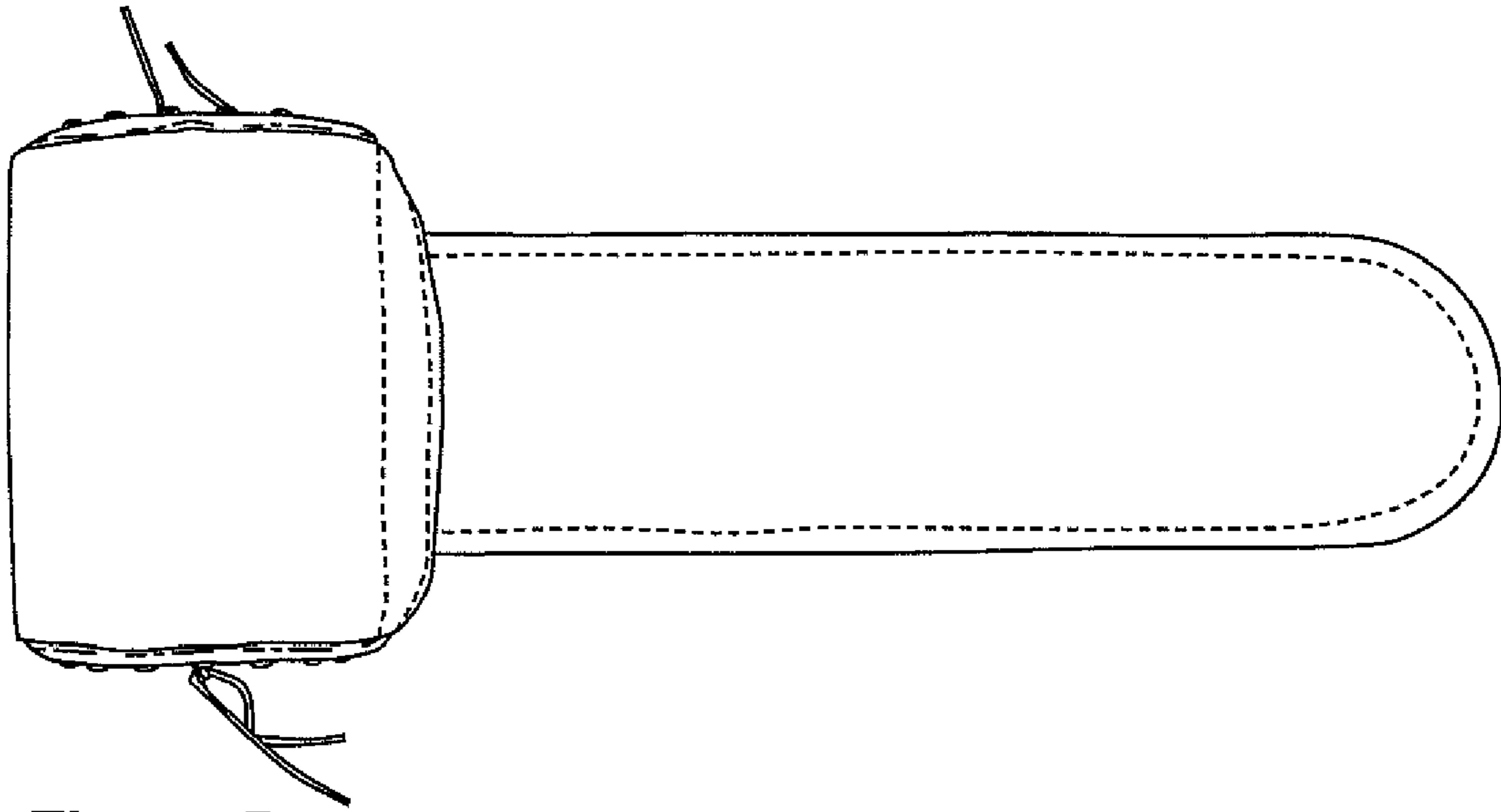

Figure 5



Figure 6

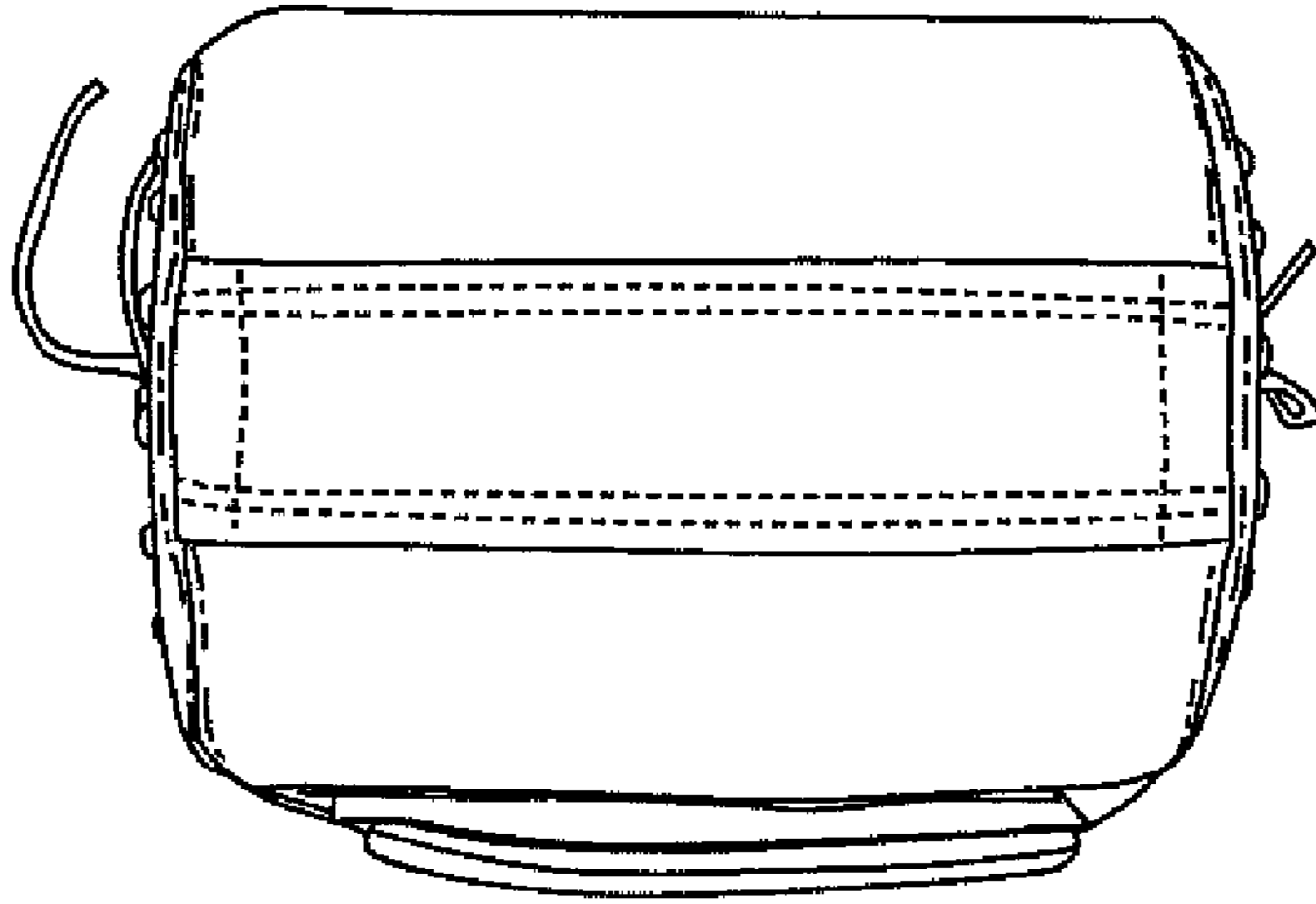

Figure 7

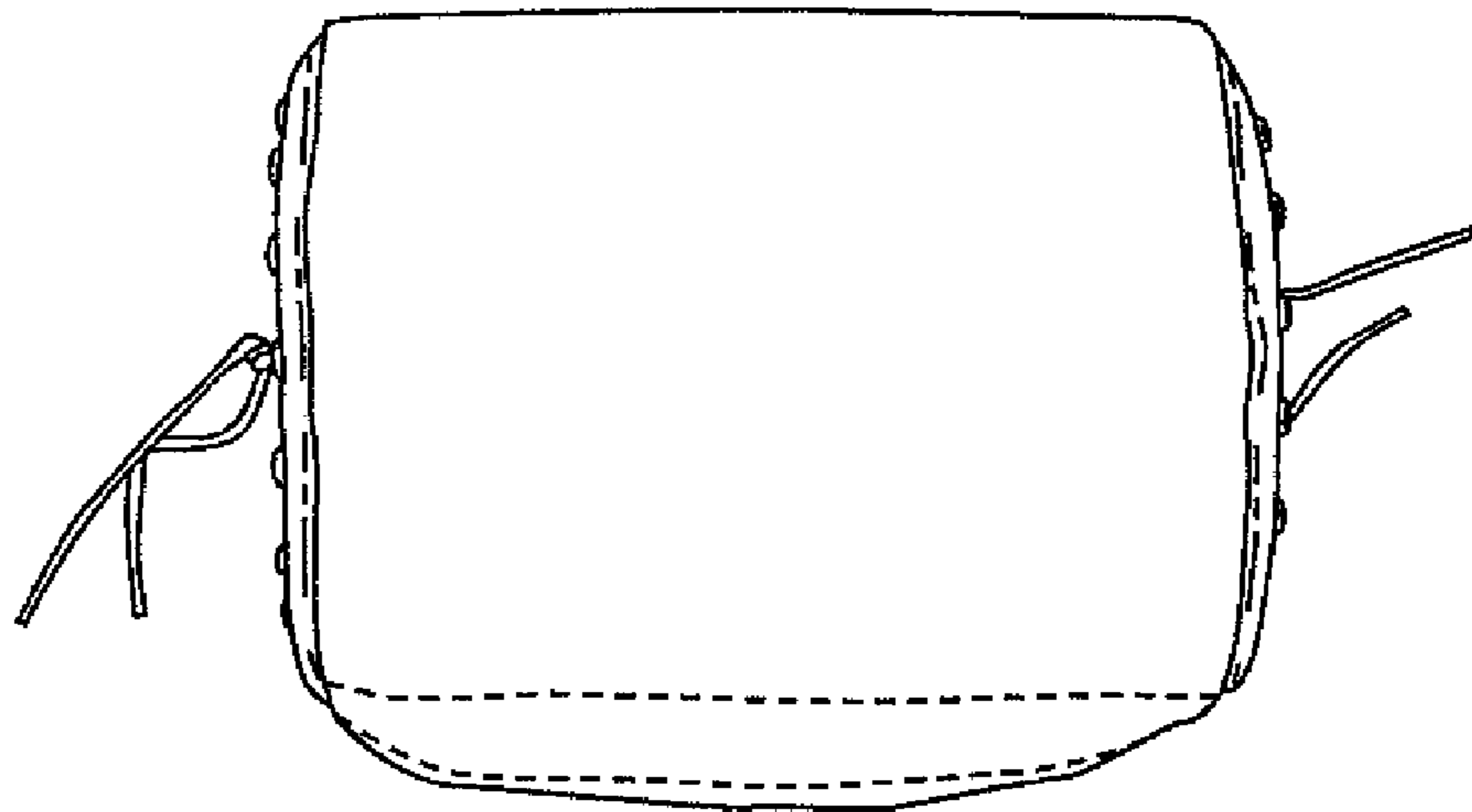

Figure 8