

US00D573613S

(12) **United States Design Patent**  
**Braun et al.**

(10) **Patent No.:** **US D573,613 S**  
(45) **Date of Patent:** **\*\* Jul. 22, 2008**

- (54) **GRILLE**
- (75) Inventors: **Joseph E. Braun**, Milwaukee, WI (US);  
**Jack L. Vaughn**, Muskego, WI (US)
- (73) Assignee: **U-Line Corporation**, Milwaukee, WI (US)
- (\*\*) Term: **14 Years**
- (21) Appl. No.: **29/295,554**
- (22) Filed: **Oct. 1, 2007**

- D439,914 S 4/2001 Trulaske, Sr.
- D518,836 S 4/2006 Reese et al.
- D520,030 S 5/2006 Reese et al.
- D520,532 S 5/2006 Reese et al.
- D520,533 S 5/2006 Reese et al.

\* cited by examiner

*Primary Examiner*—Stella M. Reid  
*Assistant Examiner*—Shanda C. Hill  
(74) *Attorney, Agent, or Firm*—Quarles & Brady LLP

**Related U.S. Application Data**

- (62) Division of application No. 29/248,706, filed on Aug. 29, 2006, now Pat. No. Des. 556,793.
- (51) **LOC (8) Cl.** ..... **15-07**
- (52) **U.S. Cl.** ..... **D15/89**
- (58) **Field of Classification Search** ..... D15/31,  
D15/79-89, 91; D14/219; D6/470, 472,  
D6/509; D7/163, 216; D23/335, 381, 382;  
62/246-255, 331, 337, 440-449; 312/114-117,  
312/128, 236, 401, 406, 407  
See application file for complete search history.

**References Cited**

**U.S. PATENT DOCUMENTS**

- D117,375 S \* 10/1939 Knight ..... D15/88
- D164,829 S \* 10/1951 Walter ..... D15/88
- 4,932,224 A 6/1990 Katterhenry et al.
- D334,201 S 3/1993 Purkapile
- D341,598 S 11/1993 Purkapile
- D379,467 S 5/1997 Martin et al.

(57) **CLAIM**

The ornamental design for a grille, as shown and described.

**DESCRIPTION**

In a preferred embodiment, the nature of this product is as grille for a cooling unit, such as a compact refrigerator, freezer, beverage cooler, ice maker, combinations thereof and the like.

FIG. 1 is a right, top, front perspective view of a grille embodying our new design;

FIG. 2 front elevational view thereof;

FIG. 3 is a top plan view thereof;

FIG. 4 is a right side elevational view thereof;

FIG. 5 is a left side elevational view thereof;

FIG. 6 is a bottom plan view thereof; and,

FIG. 7 is a rear elevational view thereof.

The broken lines shown in the drawing disclosure are for illustrative purposes only and form no part of the claimed design.

**1 Claim, 2 Drawing Sheets**

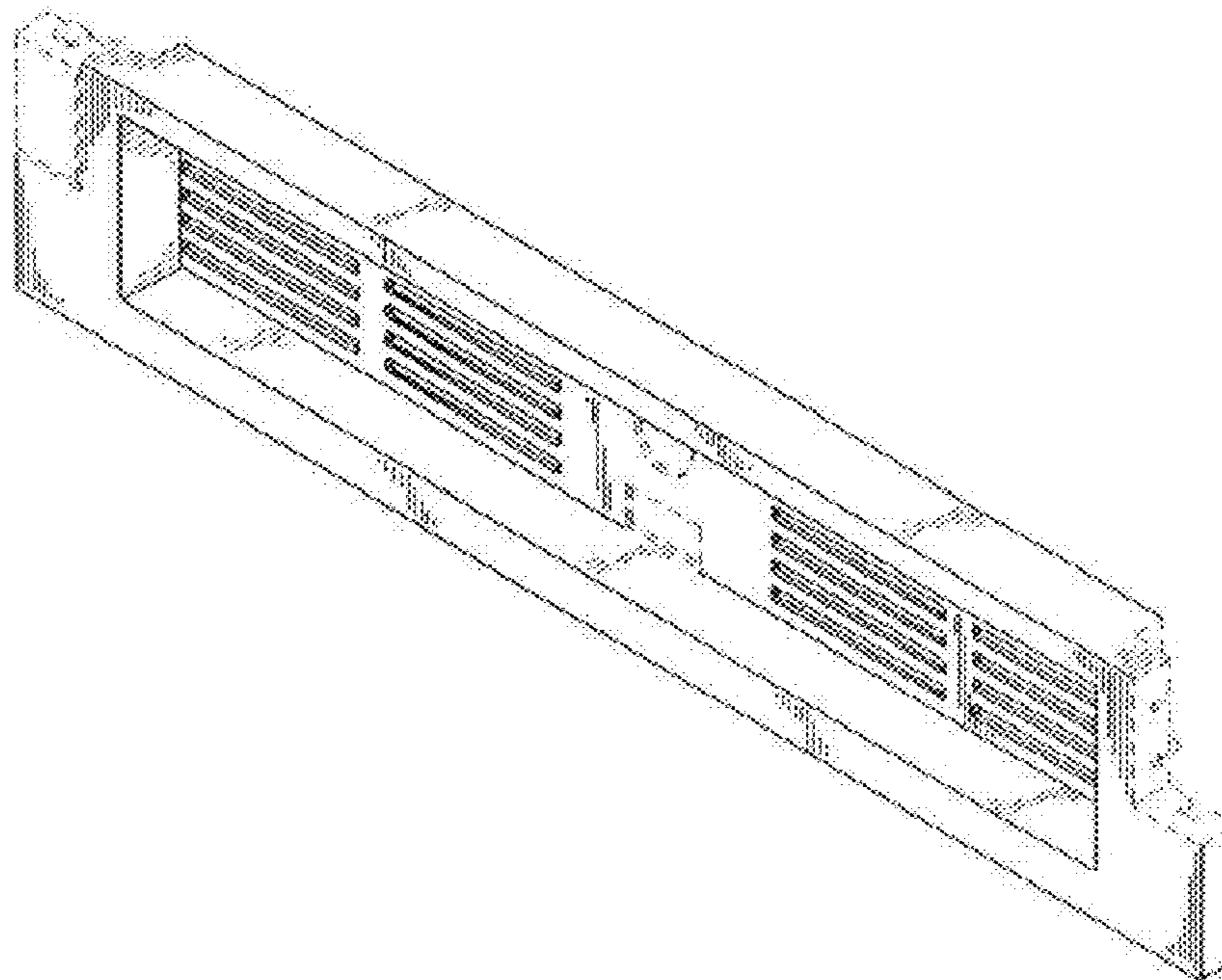

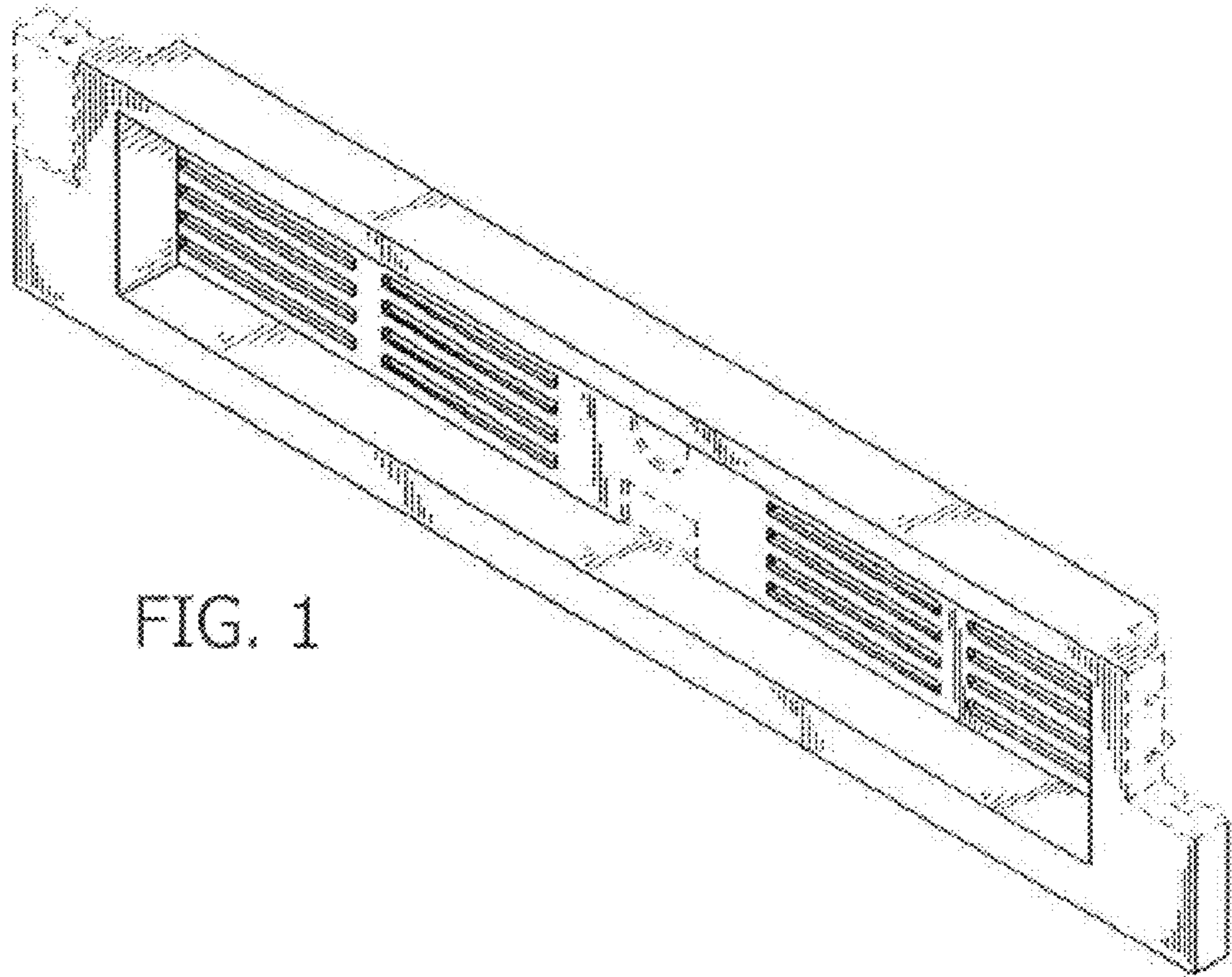

FIG. 1

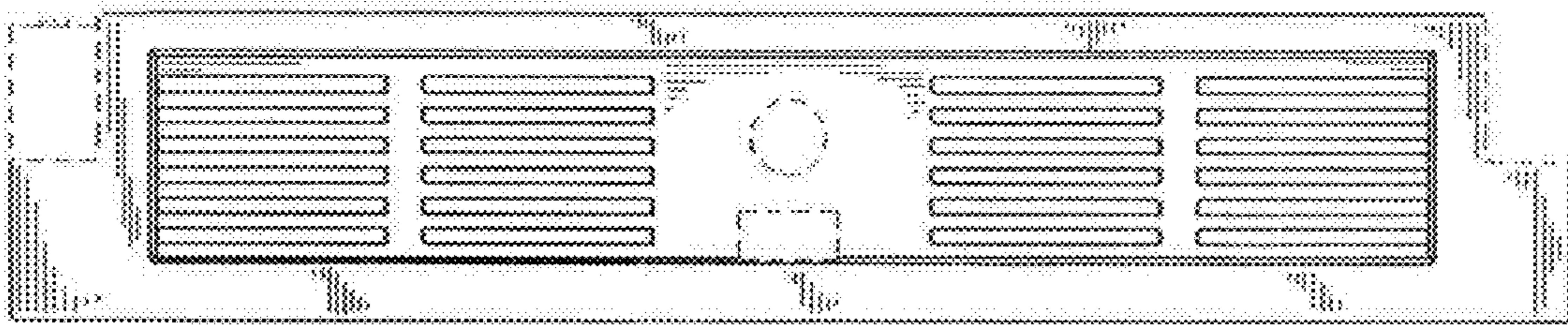

FIG. 2



FIG. 3





FIG. 4



FIG. 5

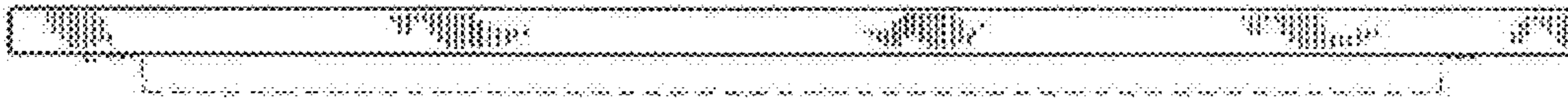

FIG. 6

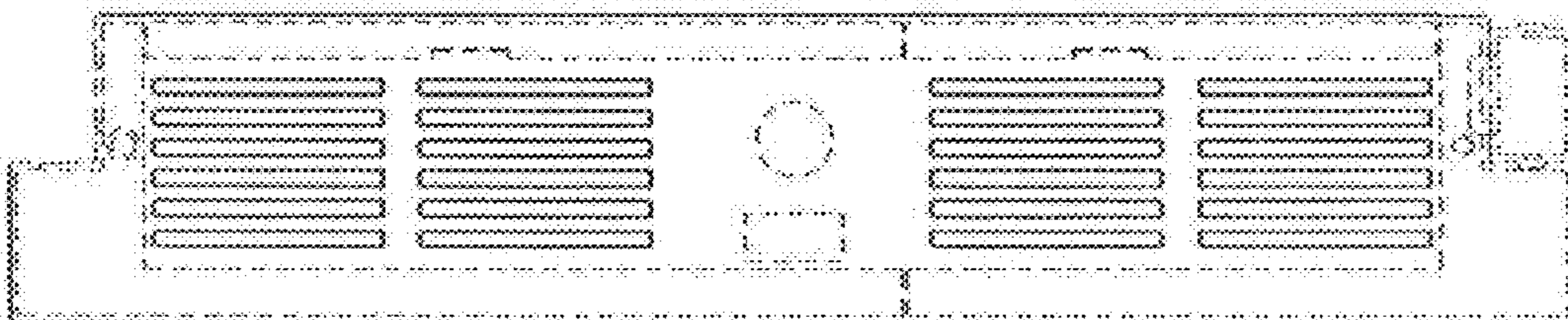

FIG. 7