



US00D573528S

(12) **United States Design Patent**  
**Roche**

(10) **Patent No.:** **US D573,528 S**  
(45) **Date of Patent:** **\*\* Jul. 22, 2008**

(54) **ELONGATED IMPLEMENT RETAINING APPARATUS**

(76) Inventor: **Phillip J. Roche**, 5301 Brooklyn Blvd., Minneapolis, MN (US) 55429

(\*\*) Term: **14 Years**

(21) Appl. No.: **29/249,454**

(22) Filed: **Oct. 6, 2006**

(51) **LOC (8) Cl.** ..... **12-16**

(52) **U.S. Cl.** ..... **D12/406; D22/147**

(58) **Field of Classification Search** ..... D12/406,  
D12/157, 190, 412, 415, 418; 296/37.8;  
297/188.14; 224/539, 553, 922, 929, 311;  
D22/147; 43/21.2; 211/70.8; 294/159; D6/552;  
312/245

See application file for complete search history.

(56) **References Cited**

**U.S. PATENT DOCUMENTS**

3,421,632	A *	1/1969	Wood	.....	211/70.8
D272,787	S *	2/1984	Rumbaugh	.....	D6/552
4,582,203	A *	4/1986	Davis	.....	211/70.8
D299,017	S *	12/1988	Renn et al.	.....	D12/414
D307,253	S *	4/1990	Roberts et al.	.....	D12/406
4,961,505	A *	10/1990	Moeller	.....	211/70.8
5,632,427	A *	5/1997	Gattuso et al.	.....	224/309
5,678,700	A *	10/1997	Crosson, Jr.	.....	211/70.8
D437,578	S *	2/2001	Stannard-Warne	.....	D12/406
D446,280	S *	8/2001	Marriott	.....	D22/147

6,360,902	B1 *	3/2002	Searles	.....	211/70.8
D463,999	S *	10/2002	Beck et al.	.....	D12/16
6,510,953	B2 *	1/2003	Daniels	.....	211/60.1
D484,453	S *	12/2003	Harris	.....	D12/406
D486,779	S *	2/2004	Alberti	.....	D12/406
6,910,592	B1 *	6/2005	Lindenmeyer	.....	211/70.8
D537,771	S *	3/2007	Pflieger	.....	D12/406
D551,420	S *	9/2007	Ezra	.....	D34/32

\* cited by examiner

*Primary Examiner*—Robert M. Spear

*Assistant Examiner*—Katrina A Kile

(74) *Attorney, Agent, or Firm*—Nawrocki, Rooney & Sivertson, P.A.

(57) **CLAIM**

The ornamental design for an elongated implement retaining apparatus, as shown and described.

**DESCRIPTION**

FIG. 1 is a perspective view of an elongated implement retaining apparatus showing my new design;

FIG. 2 is a right side elevation thereof;

FIG. 3 is a top plan view thereof;

FIG. 4 is a bottom plan view thereof;

FIG. 5 is a front elevational view thereof; and,

FIG. 6 is a rear elevational view thereof.

In the drawings, the broken lines depict environmental subject matter only and form no part of the claimed design.

**1 Claim, 2 Drawing Sheets**

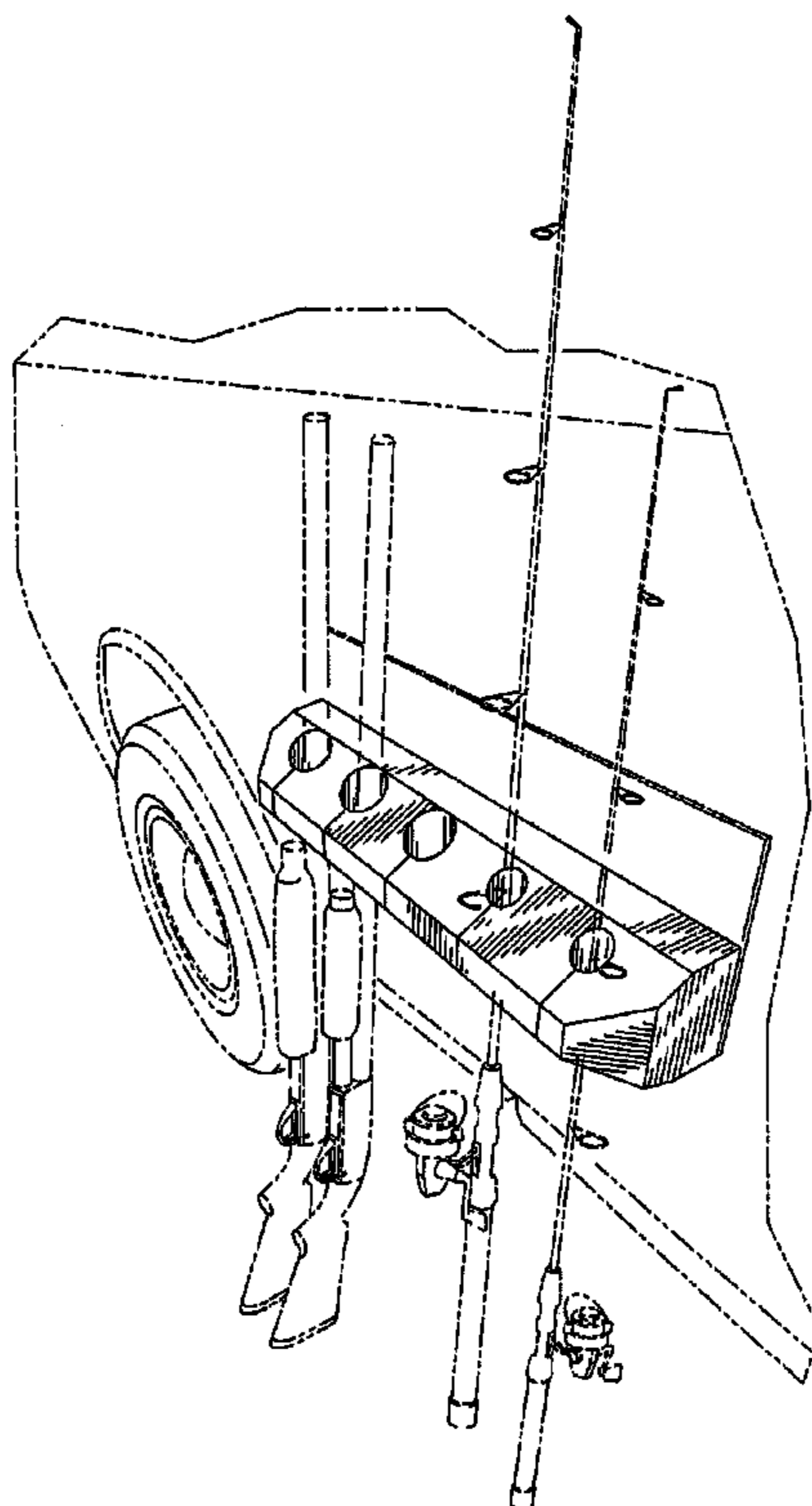

FIG. 1

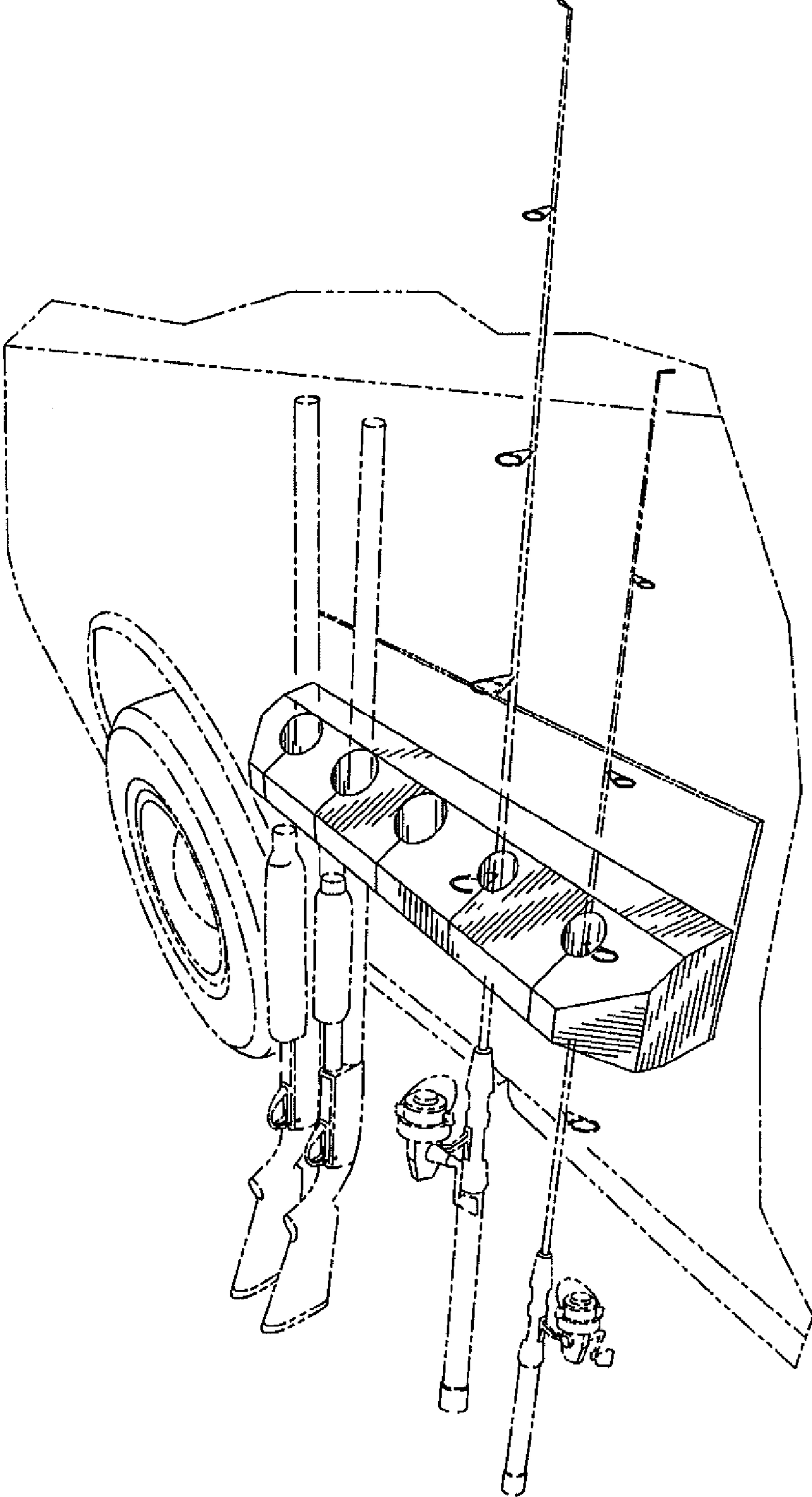

FIG. 2

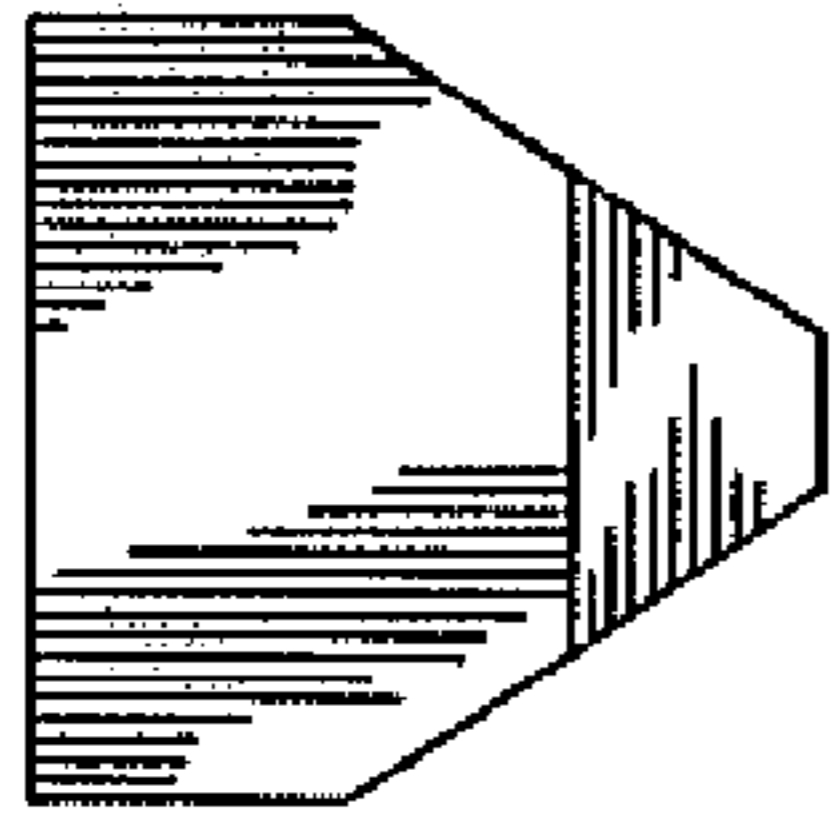

FIG. 3

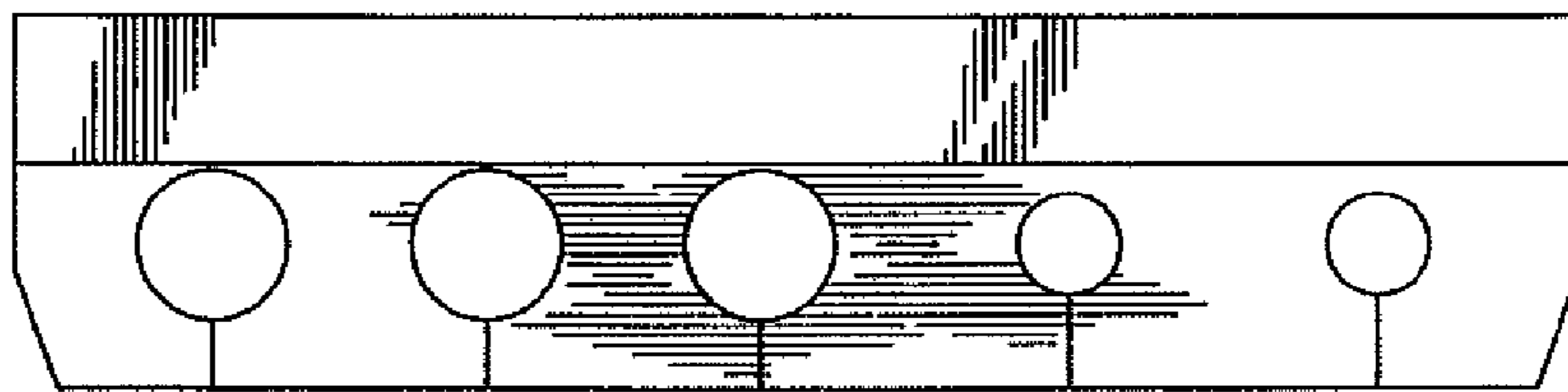

FIG. 4

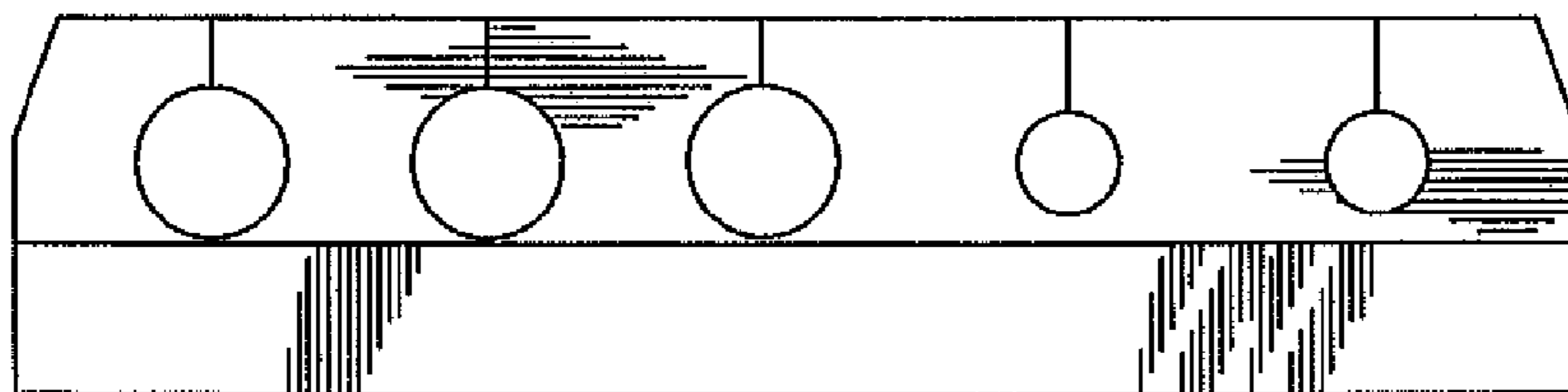

FIG. 5

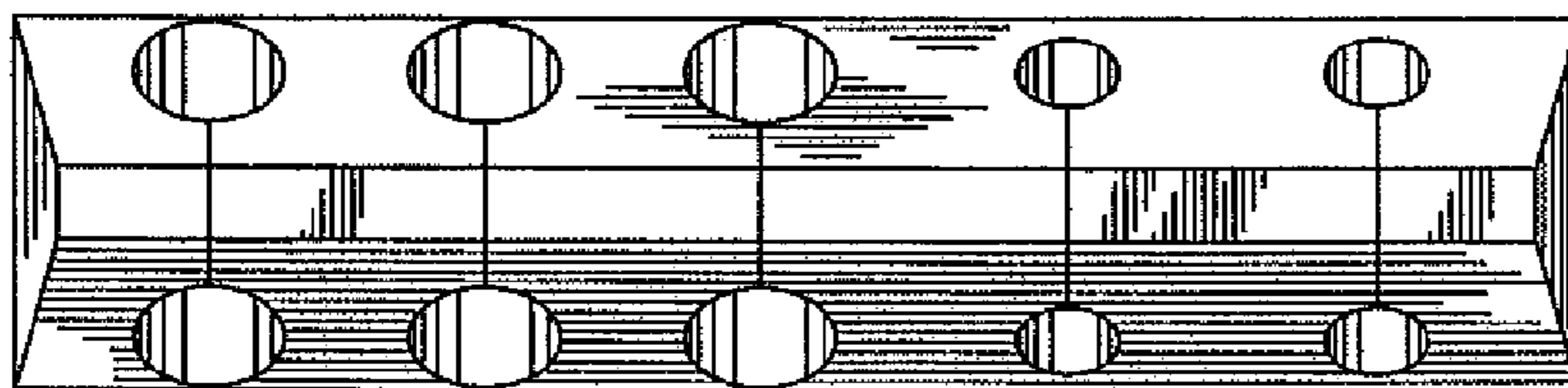

FIG. 6

