



US00D573507S

(12) **United States Design Patent**
Moushegian et al.

(10) **Patent No.:** **US D573,507 S**
(45) **Date of Patent:** **** Jul. 22, 2008**

(54) **AUTOMOBILE BODY**

(75) Inventors: **Mark T Moushegian**, San Diego, CA (US); **Clifford Wilkins**, Rochester Hills, MI (US); **Steven W Ferrerio**, Troy, MI (US)

(73) Assignee: **Chrysler LLC**, Auburn Hills, MI (US)

(**) Term: **14 Years**

(21) Appl. No.: **29/283,144**

(22) Filed: **Aug. 7, 2007**

Related U.S. Application Data

(60) Division of application No. 29/275,879, filed on Jan. 9, 2007, which is a continuation of application No. 29/244,908, filed on Dec. 15, 2005, now Pat. No. Des. 534,836.

(51) **LOC (8) Cl.** **12-08**

(52) **U.S. Cl.** **D12/91**

(58) **Field of Classification Search** D12/90-92, D12/86, 88; D21/424, 433; 296/181.1, 181.5
See application file for complete search history.

(56) **References Cited**

U.S. PATENT DOCUMENTS

D383,710 S 9/1997 Guichard et al.

D389,438 S 1/1998 Guichard et al.
D391,520 S 3/1998 Laster
D454,813 S * 3/2002 Boniface et al. D12/91
D466,444 S * 12/2002 Meadows D12/91
D497,572 S * 10/2004 Widmann et al. D12/91
D507,766 S 7/2005 McMahan et al.
D508,441 S * 8/2005 Moushegian et al. D12/91
D514,983 S * 2/2006 Renkert et al. D12/91
D534,836 S * 1/2007 Moushegian et al. D12/91
D535,585 S * 1/2007 Moushegian et al. D12/91

* cited by examiner

Primary Examiner—Melody N. Brown

(74) *Attorney, Agent, or Firm*—Ralph E. Smith

(57) **CLAIM**

The ornamental design for an automobile body, as shown and described.

DESCRIPTION

FIG. 1 is a front perspective view of an automobile body showing our new design;

FIG. 2 is a side view thereof;

FIG. 3 is a rear perspective view thereof; and,

FIG. 4 is a top plan view thereof.

It will be understood that the broken lines presented in the drawings are for illustration only, and do not form a part of the claimed design.

1 Claim, 4 Drawing Sheets

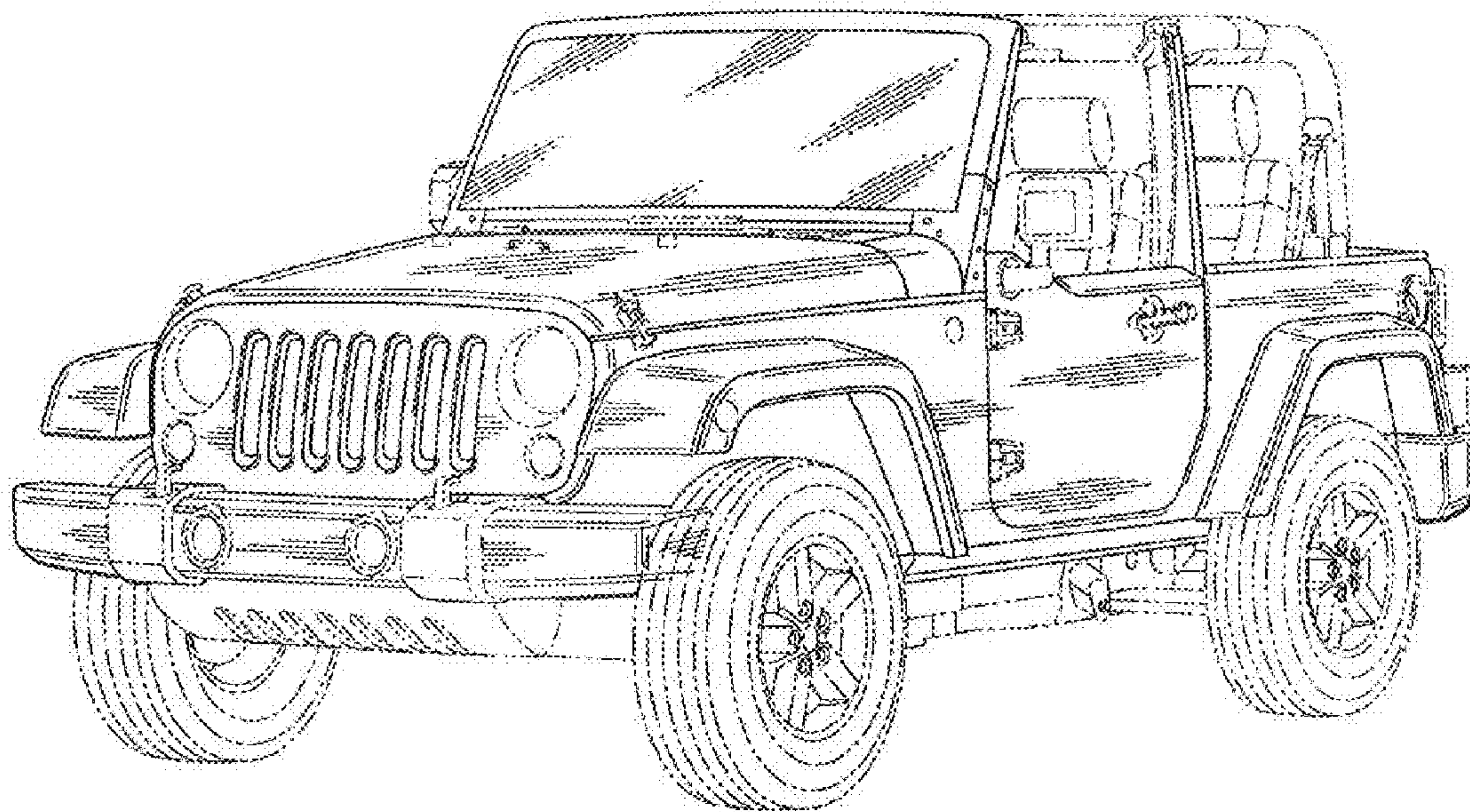

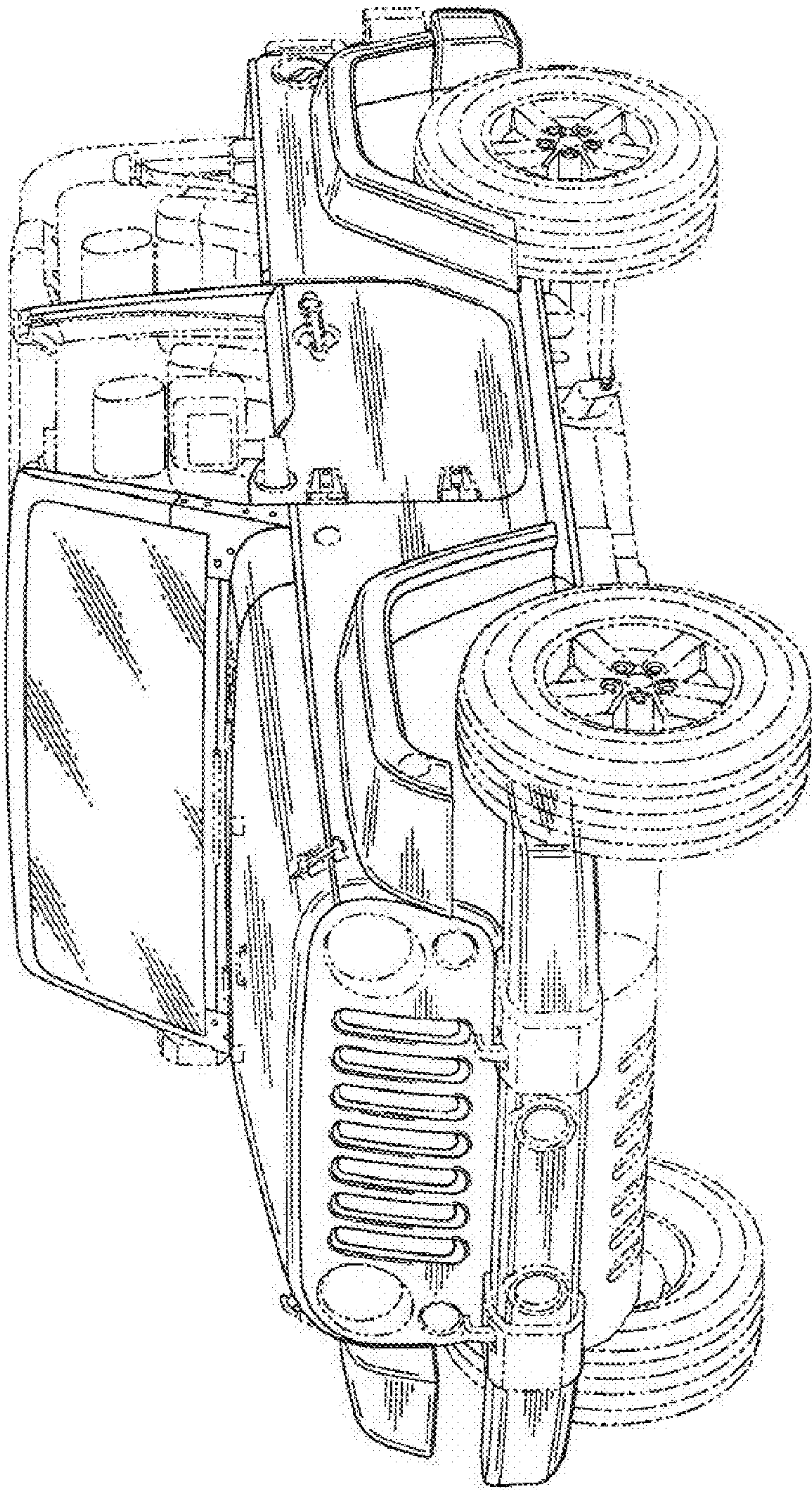

Fig. 1

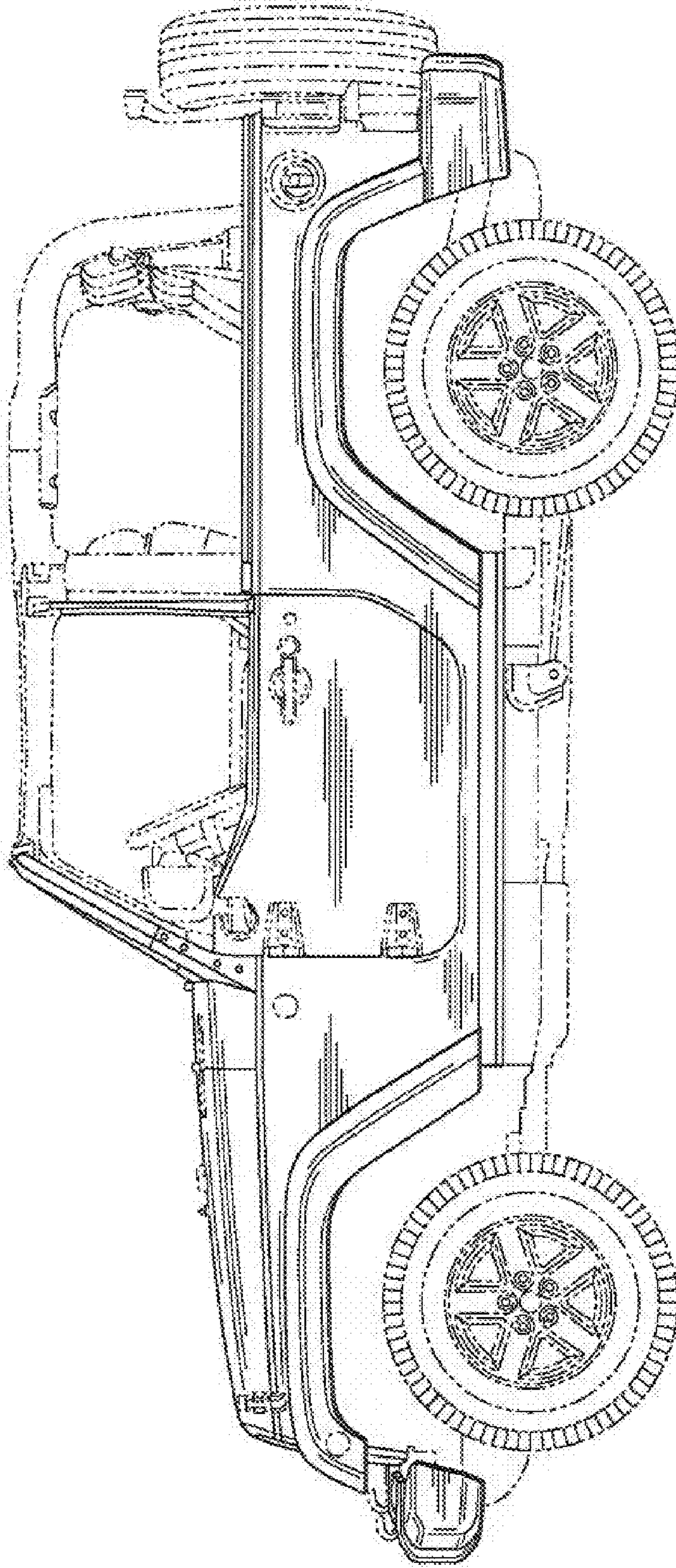

Fig. 2

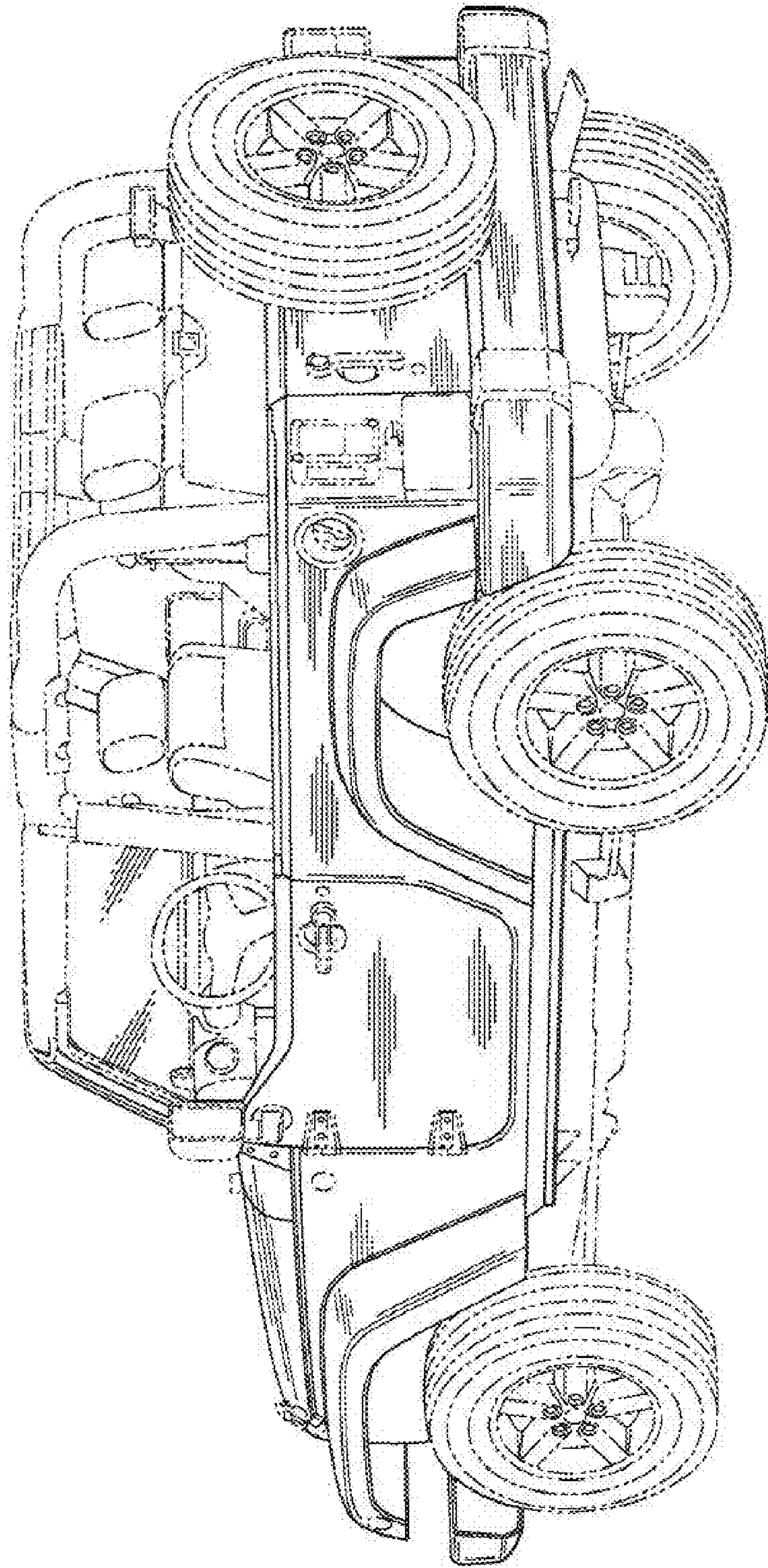

Fig. 3

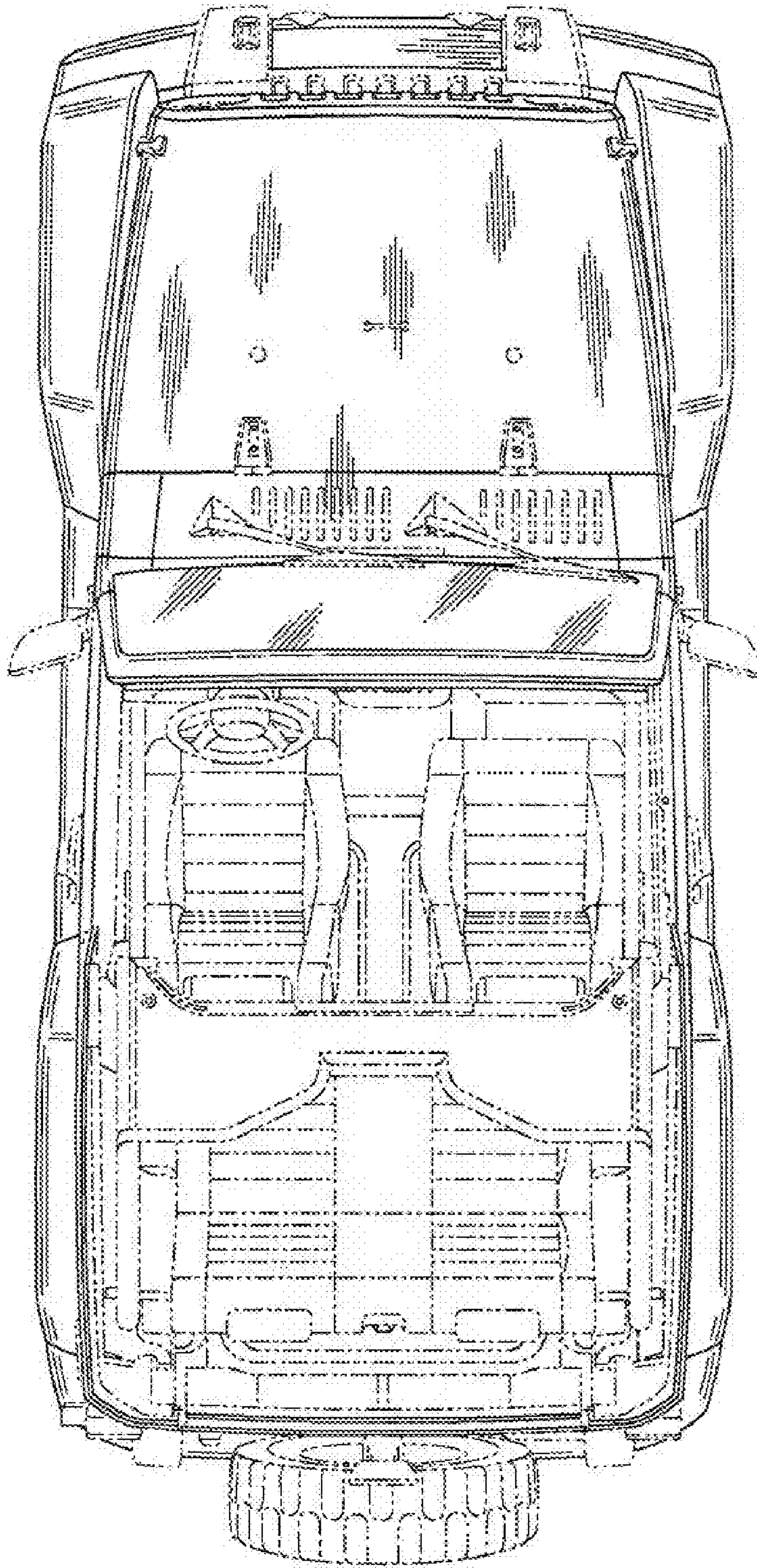

Fig. 4