



US00D573256S

(12) **United States Design Patent**  
**Mauch**

(10) **Patent No.:** **US D573,256 S**  
(45) **Date of Patent:** **\*\* Jul. 15, 2008**

(54) **INTRODUCER APPARATUS**

(75) Inventor: **Grant A Mauch**, Delano, MN (US)

(73) Assignee: **Enpath Medical, Inc.**, Plymouth, MN (US)

(\*\*) Term: **14 Years**

(21) Appl. No.: **29/278,565**

(22) Filed: **Apr. 2, 2007**

(51) **LOC (8) Cl.** ..... **24-02**

(52) **U.S. Cl.** ..... **D24/130**

(58) **Field of Classification Search** ..... D24/130,  
D24/112, 133; 604/164.01, 164.05, 165.3,  
604/167, 160, 161, 523, 264

See application file for complete search history.

(56) **References Cited**

**U.S. PATENT DOCUMENTS**

4,741,732	A *	5/1988	Crankshaw et al.	.....	604/503
5,098,392	A *	3/1992	Fleischhacker et al.		604/164.05
D363,543	S *	10/1995	Van Funderburk et al.	.	D24/130
6,013,057	A *	1/2000	Danby et al.	.....	604/131
D430,290	S *	8/2000	Cindrich et al.	.....	D24/112
D450,839	S *	11/2001	Junker	.....	D24/130
6,336,914	B1 *	1/2002	Gillespie, III	.....	604/165.01
6,692,464	B2 *	2/2004	Graf	.....	604/160
6,796,991	B2 *	9/2004	Nardeo	.....	606/191
D532,513	S *	11/2006	Eddings	.....	D24/127
2003/0120258	A1 *	6/2003	Ashby et al.	.....	604/523
2005/0010238	A1 *	1/2005	Potter et al.	.....	606/129
2005/0090779	A1 *	4/2005	Osypka	.....	604/160
2006/0041230	A1 *	2/2006	Davis	.....	604/160
2006/0106345	A1 *	5/2006	Flaker et al.	.....	604/131

2006/0149293	A1 *	7/2006	King et al.	.....	606/108
2007/0123825	A1 *	5/2007	King et al.	.....	604/160
2007/0135794	A1 *	6/2007	Raulerson et al.	.....	604/523

\* cited by examiner

*Primary Examiner*—Louis S Zarfaz

*Assistant Examiner*—Eric L Goodman

(74) *Attorney, Agent, or Firm*—Schwegman, Lundberg, & Woessner, P.A.

(57) **CLAIM**

The ornamental design for an introducer apparatus, as shown and described.

**DESCRIPTION**

FIG. 1 is a front isometric view of an introducer apparatus in accordance with one embodiment.

FIG. 2 is a front elevational view of the introducer apparatus of FIG. 1.

FIG. 3 is a rear elevational view of the introducer apparatus of FIG. 1.

FIG. 4 is a first side elevational view of the introducer apparatus of FIG. 1.

FIG. 5 is a second side elevational view of the introducer apparatus of FIG. 1.

FIG. 6 is a top plan view of the introducer apparatus of FIG. 1.

The bottom view does not form a part of the design.

The broken line showing is included for the purpose of illustrating portions of the article and forms no part of the claimed design.

**1 Claim, 5 Drawing Sheets**

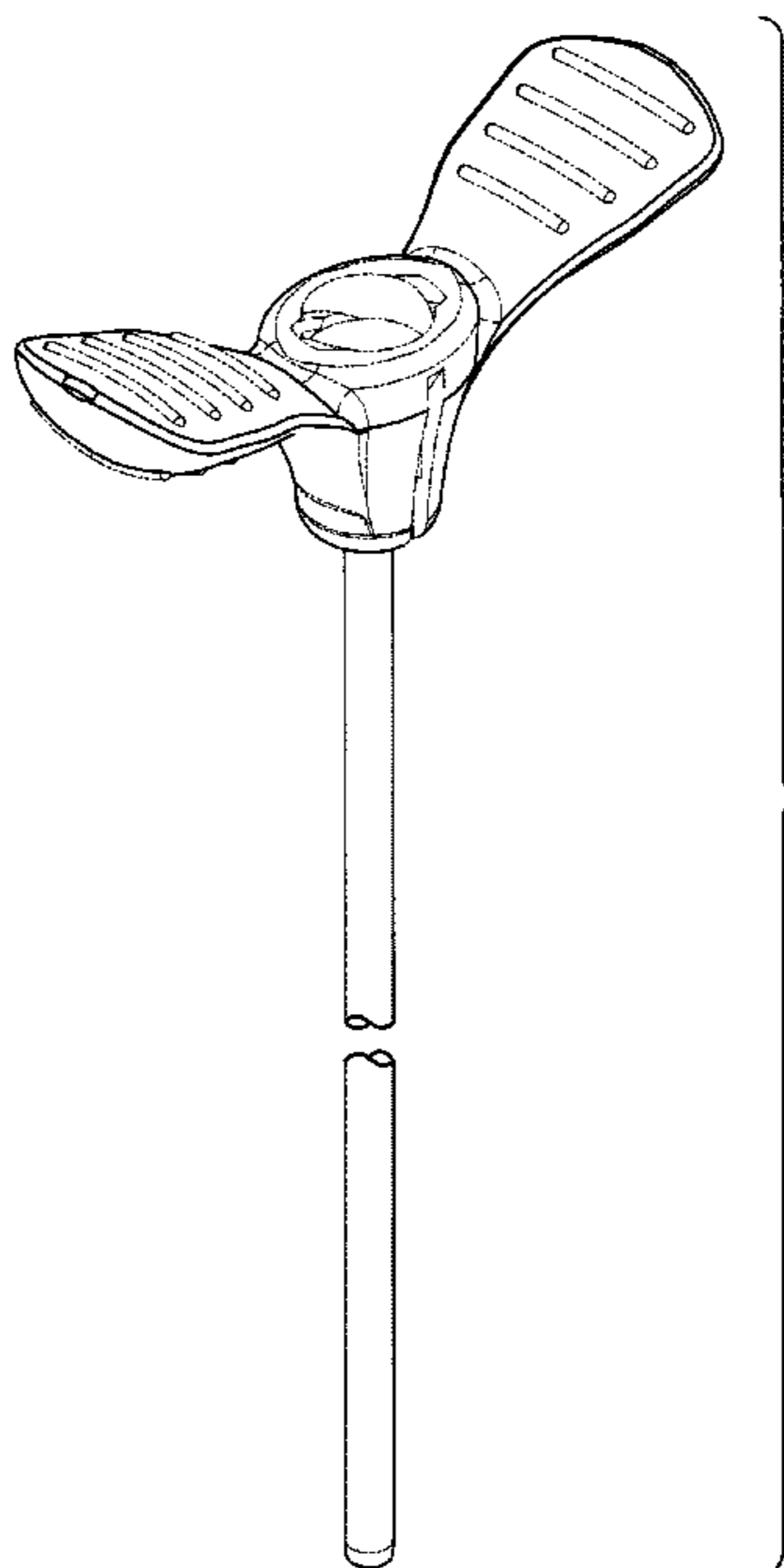

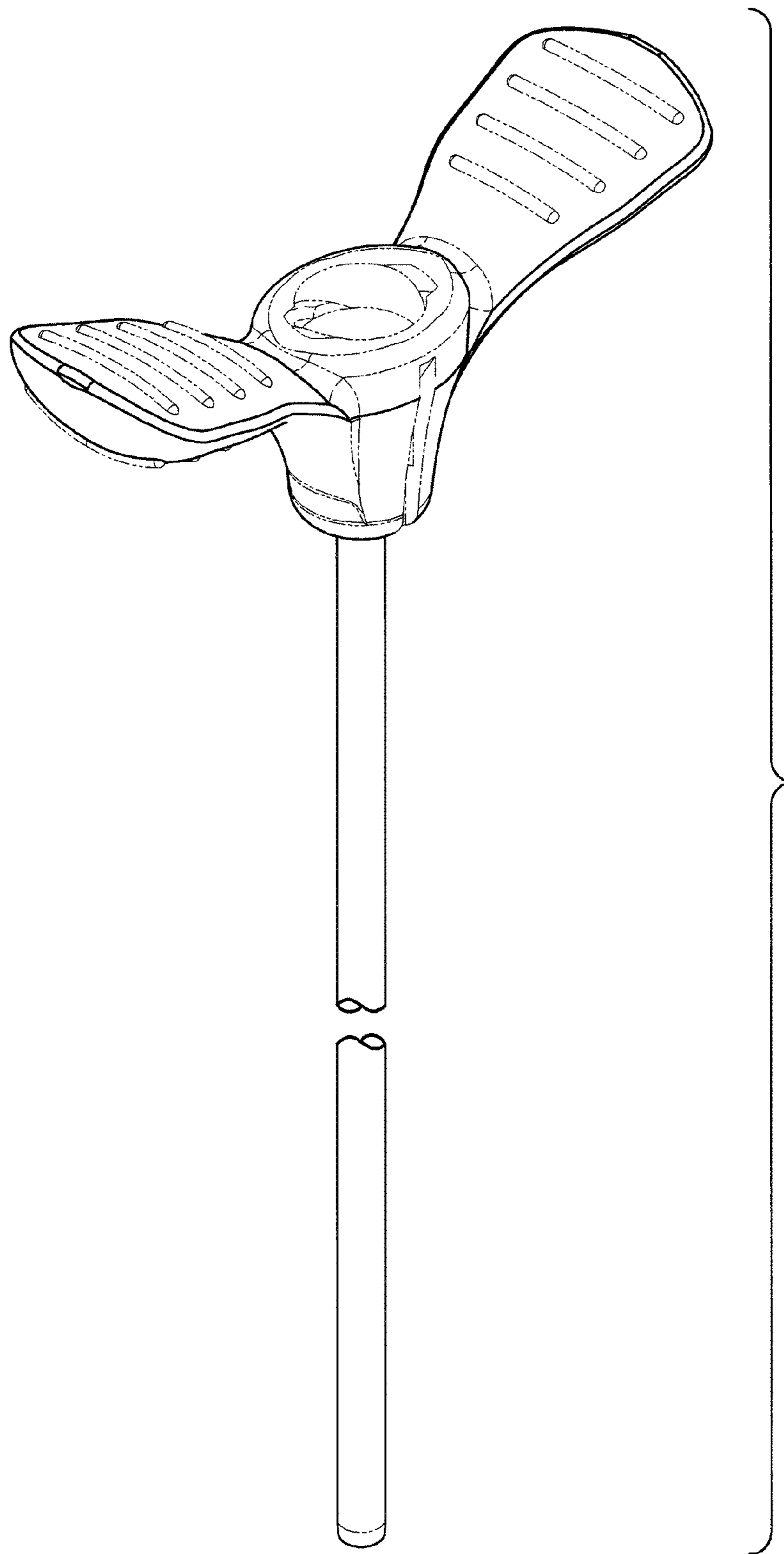

FIG. 1

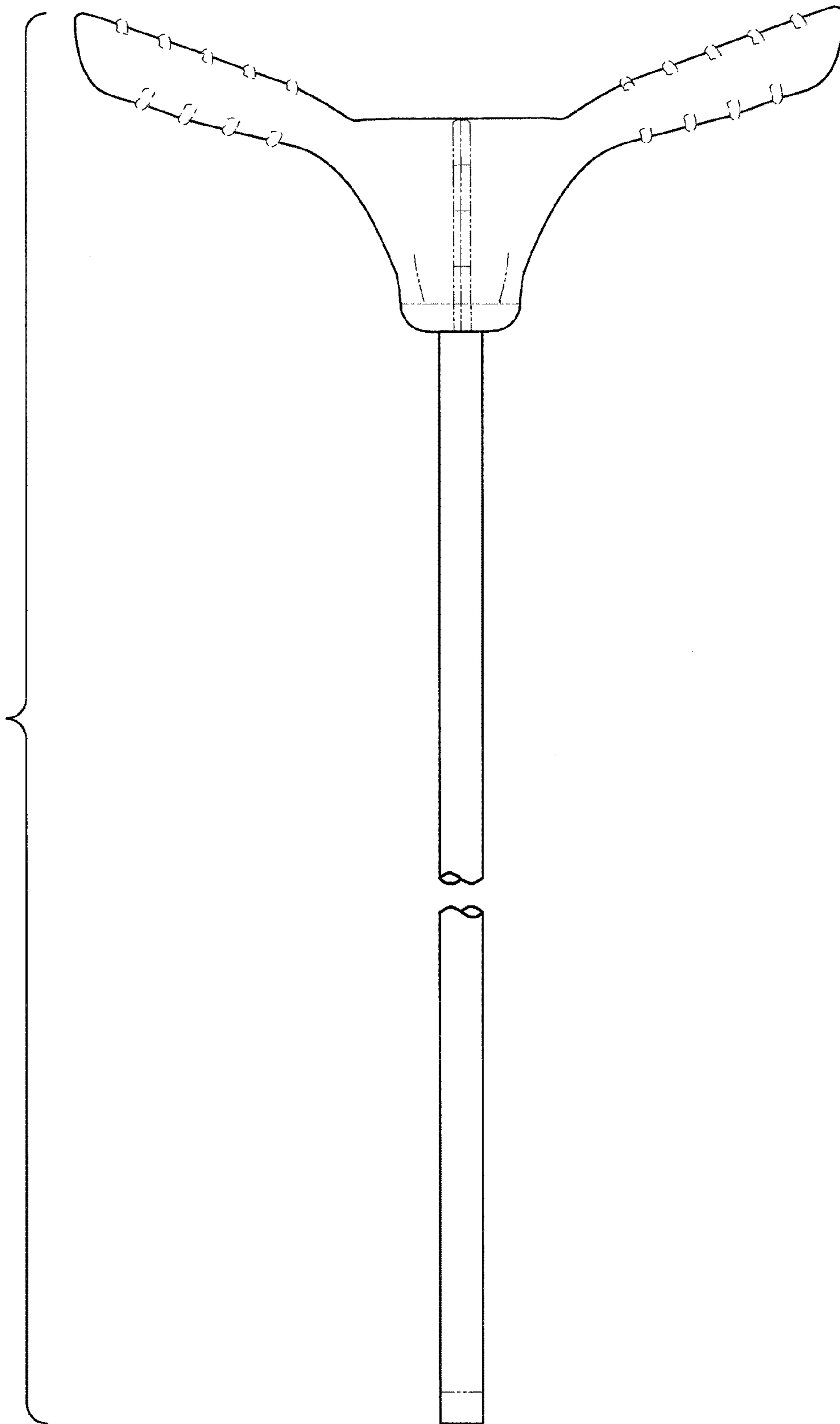

FIG. 2

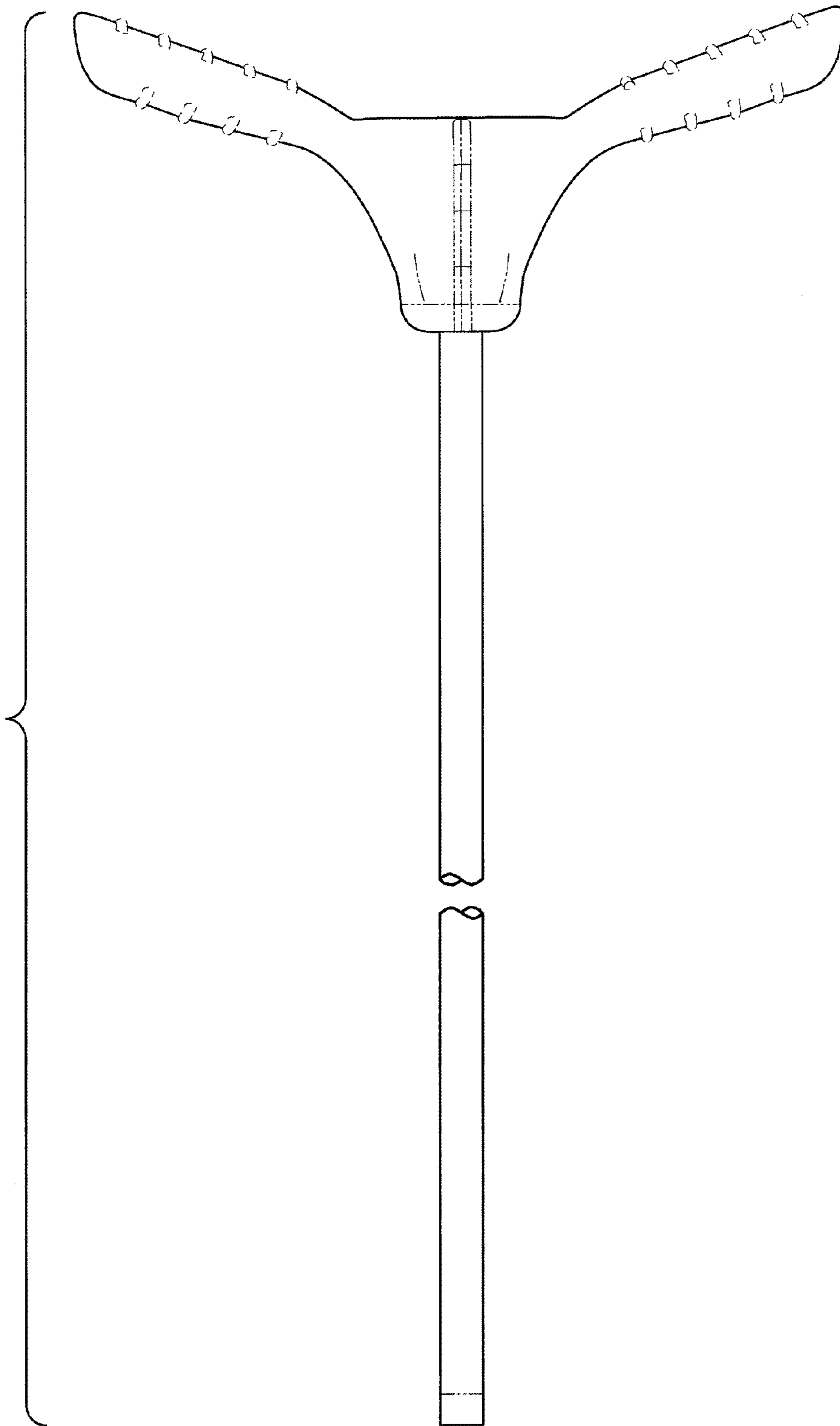
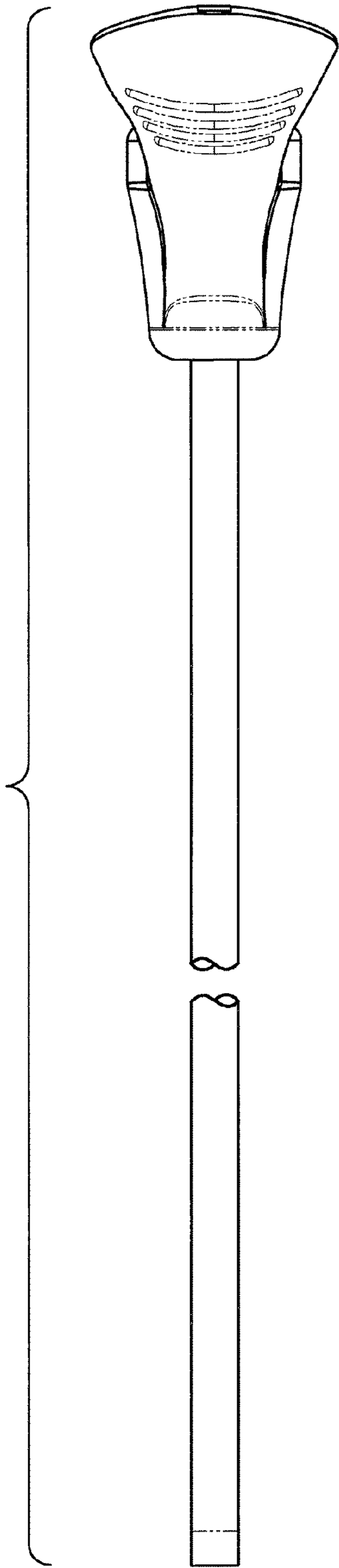
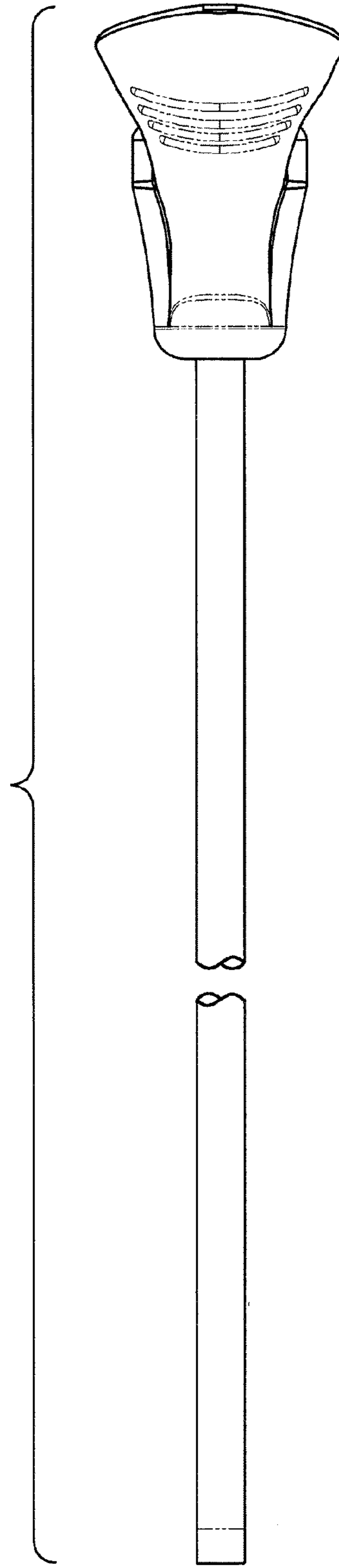

FIG. 3



*FIG. 4*



*FIG. 5*

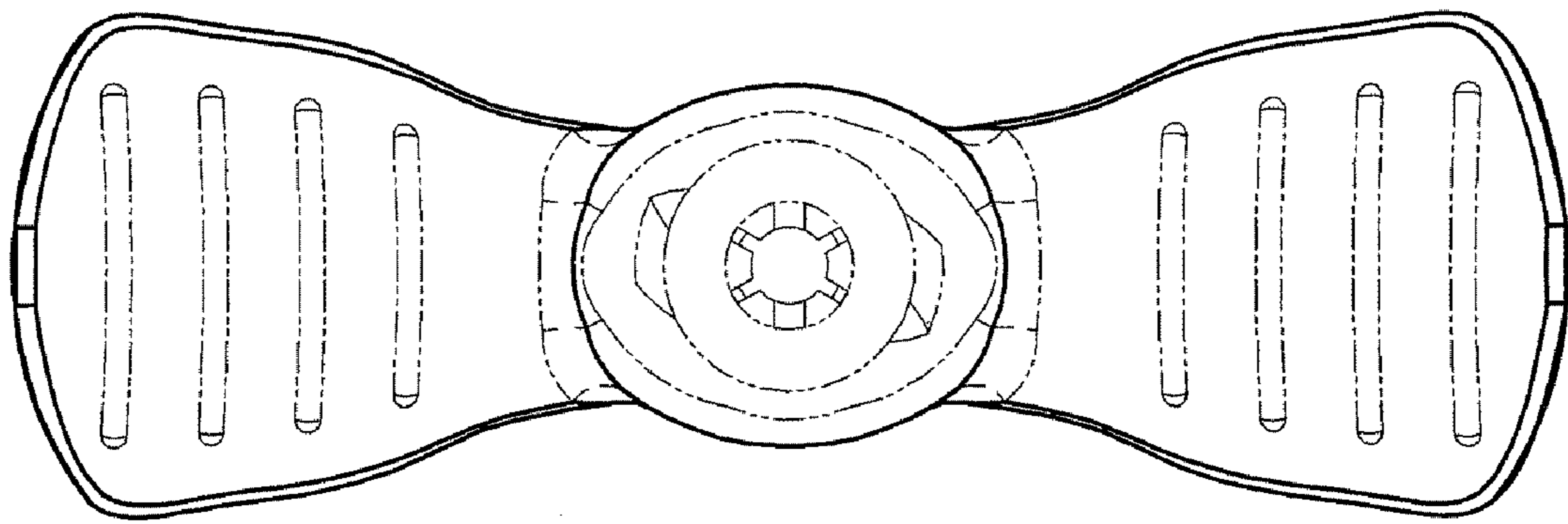

*FIG. 6*