



US00D573240S

(12) **United States Design Patent**
Quinn et al.

(10) **Patent No.:** **US D573,240 S**
(45) **Date of Patent:** **** Jul. 15, 2008**

(54) **AIR DRYER SYSTEM**

(75) Inventors: **Leonard A. Quinn**, Lagrange, OH (US);
Fred W. Hoffman, Columbia Station,
OH (US)

(73) Assignee: **Bendix Commercial Vehicle Systems**
LLC, Elyria, OH (US)

(**) Term: **14 Years**

(21) Appl. No.: **29/270,732**

(22) Filed: **Jan. 3, 2007**

Related U.S. Application Data

(62) Division of application No. 29/203,714, filed on Apr.
19, 2004, now Pat. No. Des. 546,431.

(51) **LOC (8) Cl.** **23-04**

(52) **U.S. Cl.** **D23/359**

(58) **Field of Classification Search** D23/355,
D23/364-5, 356, 359; 55/385.3, DIG. 17;
96/147; 34/80

See application file for complete search history.

(56) **References Cited**

U.S. PATENT DOCUMENTS

1,993,201 A 3/1935 **Yandell**
(Continued)

Primary Examiner—Robin V Webster

(74) *Attorney, Agent, or Firm*—Calfee Halter & Griswold,
LLP

(57) **CLAIM**

The ornamental design for an air dryer system, as shown and
described.

DESCRIPTION

FIG. 1 is a perspective view of an air dryer system of the
present invention;

FIG. 2 is a side view of the air dryer system shown in FIG. 1;

FIG. 3 is a front view of the air dryer system shown in FIG. 1;

FIG. 4 is a side view of the air dryer system shown in FIG. 1;

FIG. 5 is a back view of the air dryer system shown in FIG. 1;

FIG. 6 is a top view of the air dryer system shown in FIG. 1;

FIG. 7 is a bottom view of the air dryer system shown in FIG.
1;

FIG. 8 is a perspective view of a second embodiment of an air
dryer system of the present invention;

FIG. 9 is a side view of the air dryer system shown in FIG. 8;

FIG. 10 is a front view of the air dryer system shown in FIG.
8;

FIG. 11 is a side view of the air dryer system shown in FIG. 8;

FIG. 12 is a back view of the air dryer system shown in FIG.
8;

FIG. 13 is a top view of the air dryer system shown in FIG. 8;

FIG. 14 is a bottom view of the air dryer system shown in FIG.
8;

FIG. 15 is a perspective view of a third embodiment of an air
dryer system of the present invention;

FIG. 16 is a side view of the air dryer system shown in FIG.
15;

FIG. 17 is a front view of the air dryer system shown in FIG.
15;

FIG. 18 is a side view of the air dryer system shown in FIG. 15;

FIG. 19 is a back view of the air dryer system shown in FIG.
15;

FIG. 20 is a top view of the air dryer system shown in FIG. 15;

FIG. 21 is a bottom view of the air dryer system shown in FIG.
15;

FIG. 22 is a perspective view of a fourth embodiment of an air
dryer system of the present invention;

FIG. 23 is a side view of the air dryer system shown in FIG.
22;

FIG. 24 is a front view of the air dryer system shown in FIG.
22;

FIG. 25 is a side view of the air dryer system shown in FIG. 22;

FIG. 26 is a back view of the air dryer system shown in FIG.
22;

FIG. 27 is a top view of the air dryer system shown in FIG. 22;
and,

FIG. 28 is a bottom view of the air dryer system shown in FIG.
22.

The portions of the Figures shown in phantom lines are not
part of the claimed design but are for illustration only.

1 Claim, 16 Drawing Sheets

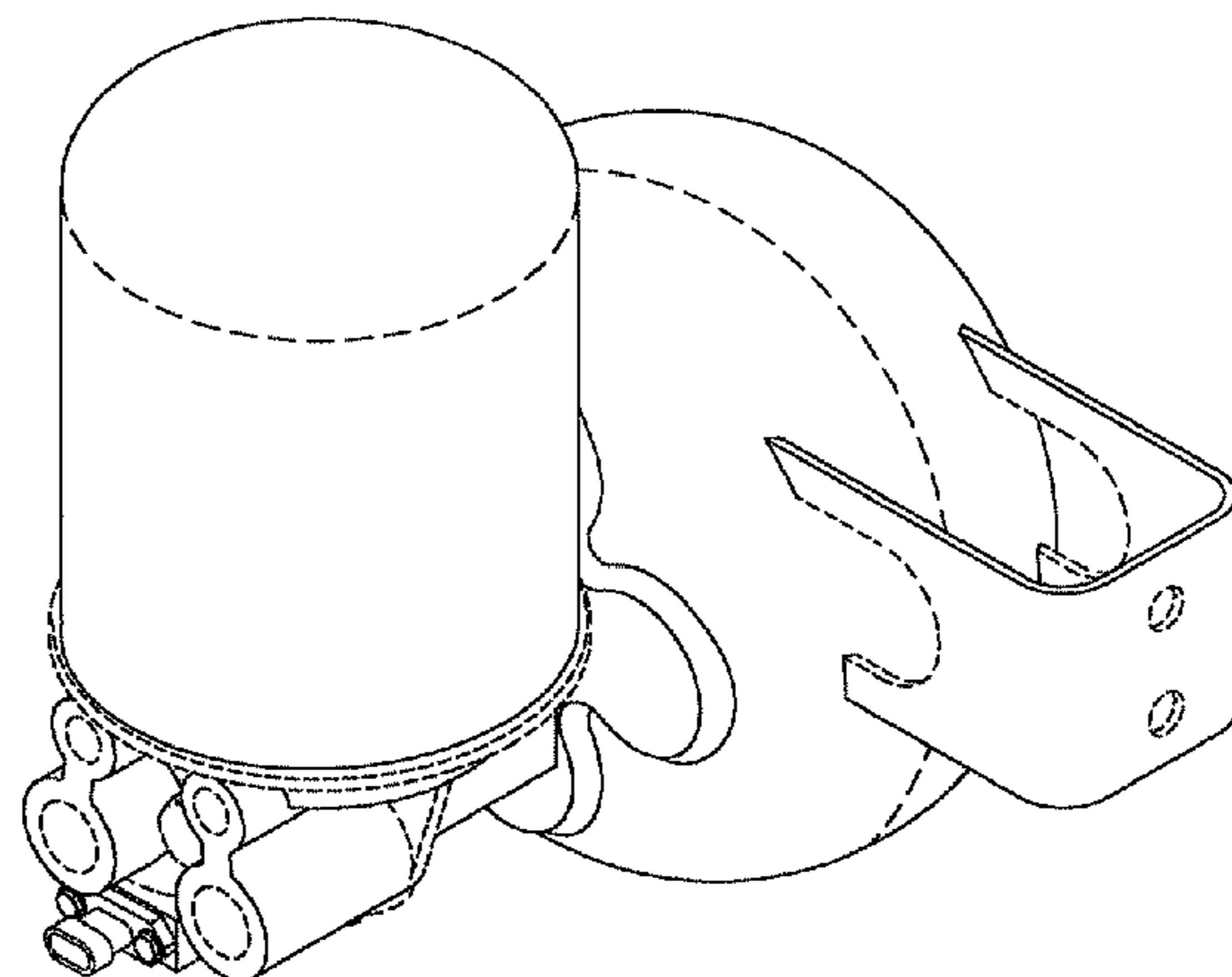
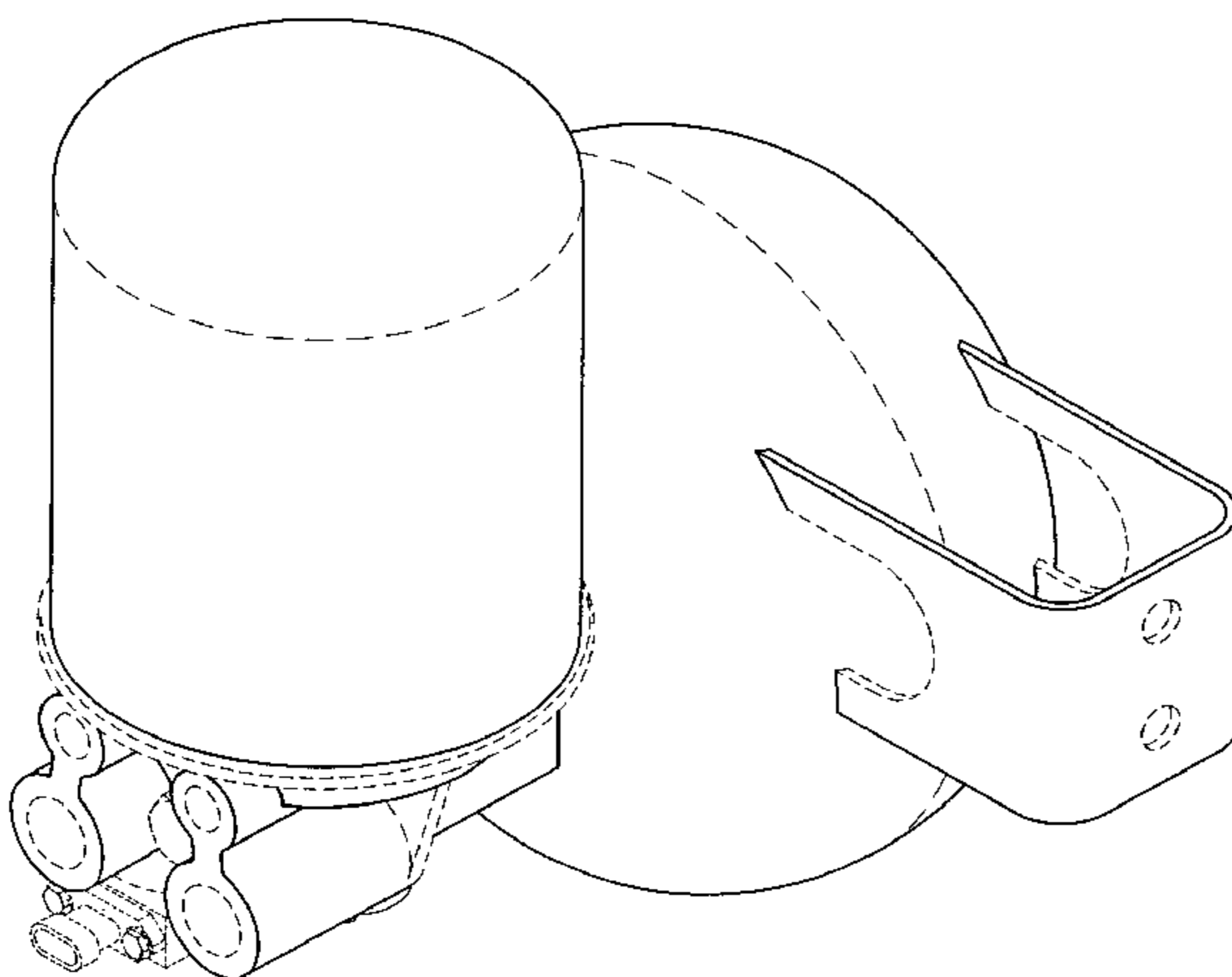

US D573,240 S

Page 2

U.S. PATENT DOCUMENTS					
2,606,628	A	8/1952 Hasselwander	5,595,588	A	1/1997 Blevins
3,353,339	A	11/1967 Walter	5,607,500	A	3/1997 Shamine et al.
4,052,178	A	10/1977 Frantz	5,622,544	A	4/1997 Shamine et al.
4,065,096	A	12/1977 Frantz et al.	5,792,245	A *	8/1998 Unger et al. 96/137
4,385,913	A	5/1983 Lane	5,851,269	A *	12/1998 Strobe 96/144
4,544,385	A	10/1985 Tanaka	5,961,698	A	10/1999 Dossaji et al.
4,572,725	A	2/1986 Kojima	6,076,272	A	6/2000 Conklin, III et al.
4,655,801	A	4/1987 Kojima et al.	6,094,836	A	8/2000 Mahoney et al.
4,673,419	A	6/1987 Kojima	6,322,159	B1	11/2001 Eberling
4,707,166	A	11/1987 Khosropour	6,322,161	B1	11/2001 Maslonka et al.
4,713,094	A *	12/1987 Yanagawa et al. 96/147	6,391,098	B1	5/2002 Thomas
4,764,189	A	8/1988 Yanagawa et al.	6,450,587	B1	9/2002 MacGregor et al.
5,110,327	A	5/1992 Smith	6,585,806	B2	7/2003 Quinn et al.
5,252,034	A	10/1993 Sweet	6,585,810	B1 *	7/2003 Gaita et al. 96/135
D341,224	S	11/1993 Drake et al.	6,730,143	B1	5/2004 Nichols et al.
5,286,283	A	2/1994 Goodell	6,824,594	B2 *	11/2004 Larsson 96/109
5,403,387	A	4/1995 Flynn et al.	6,878,194	B2	4/2005 Hoffman et al.
5,427,609	A	6/1995 Zoglman et al.	7,100,305	B2	9/2006 Hoffman et al.
			2002/0189456	A1	12/2002 Hoffman et al.

* cited by examiner

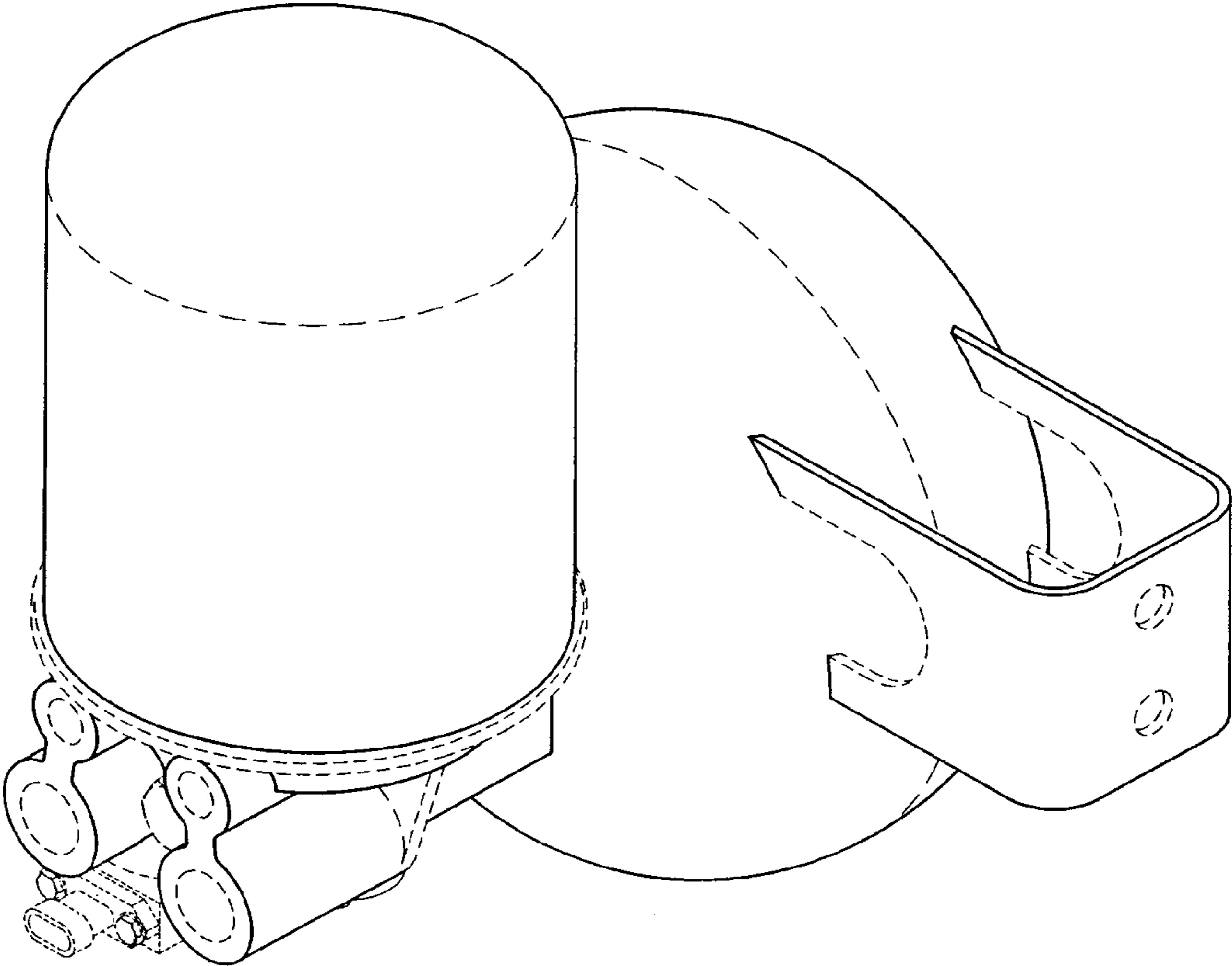

FIG. 1

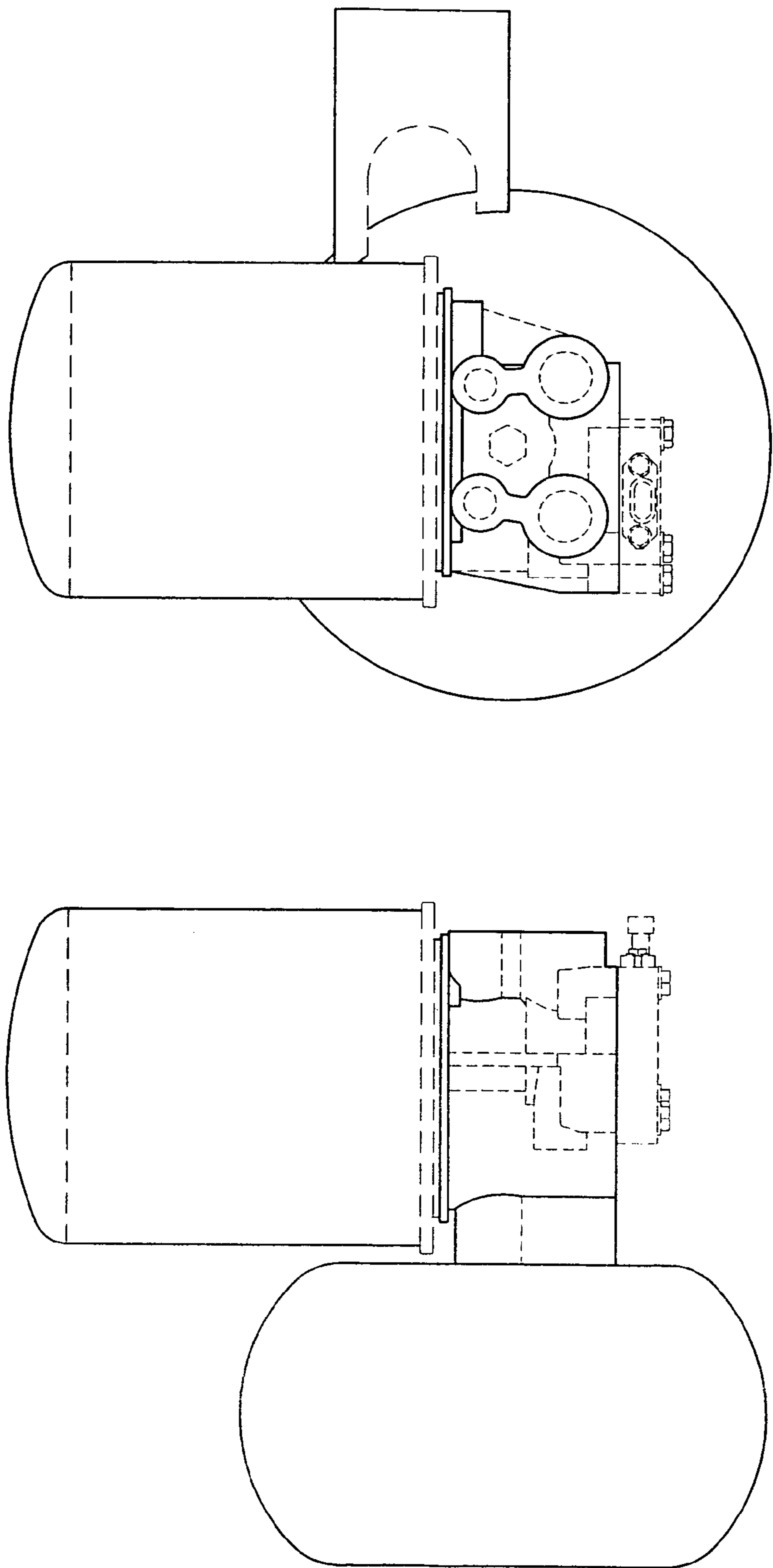

FIG. 3

FIG. 2

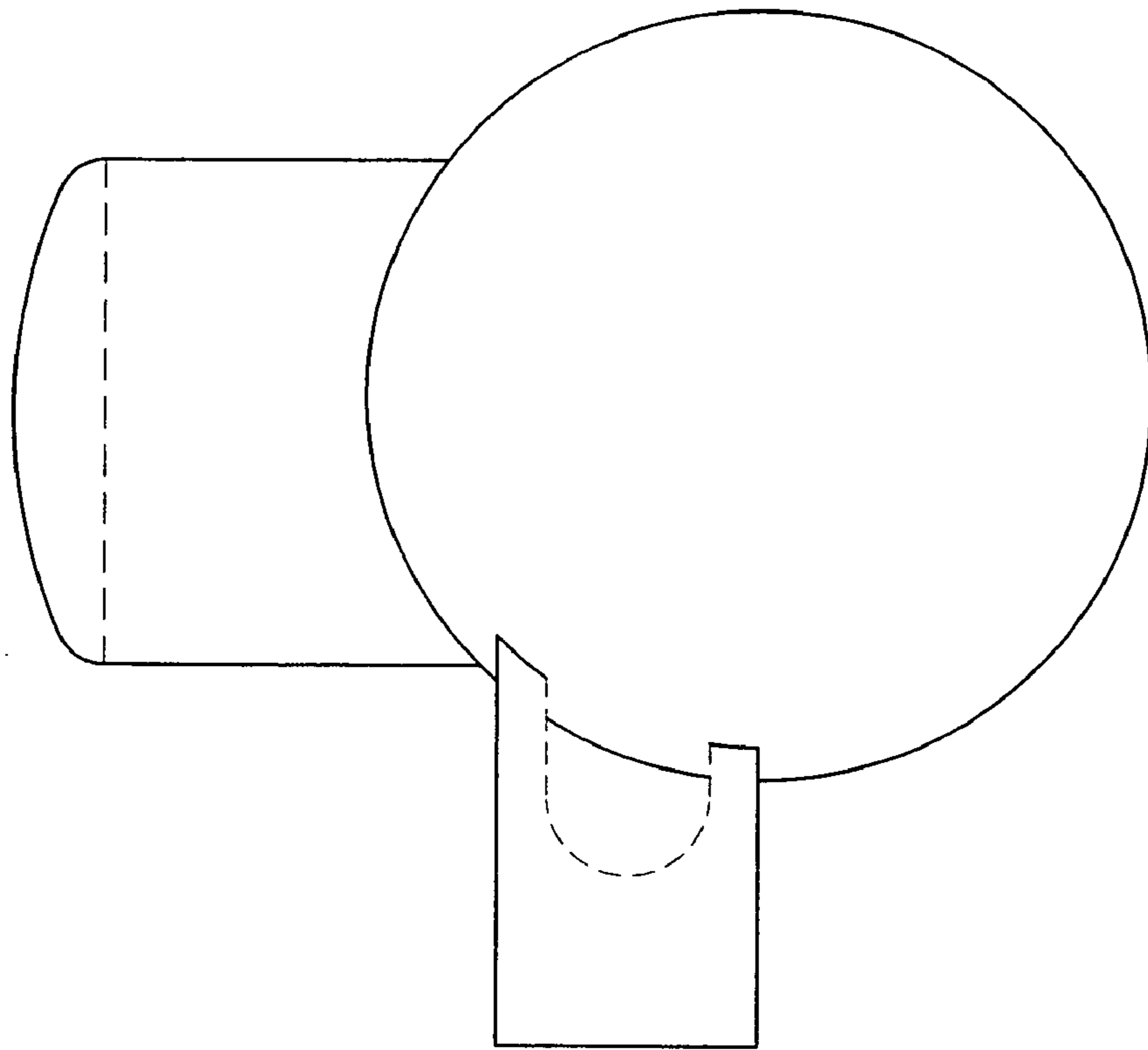

FIG. 5

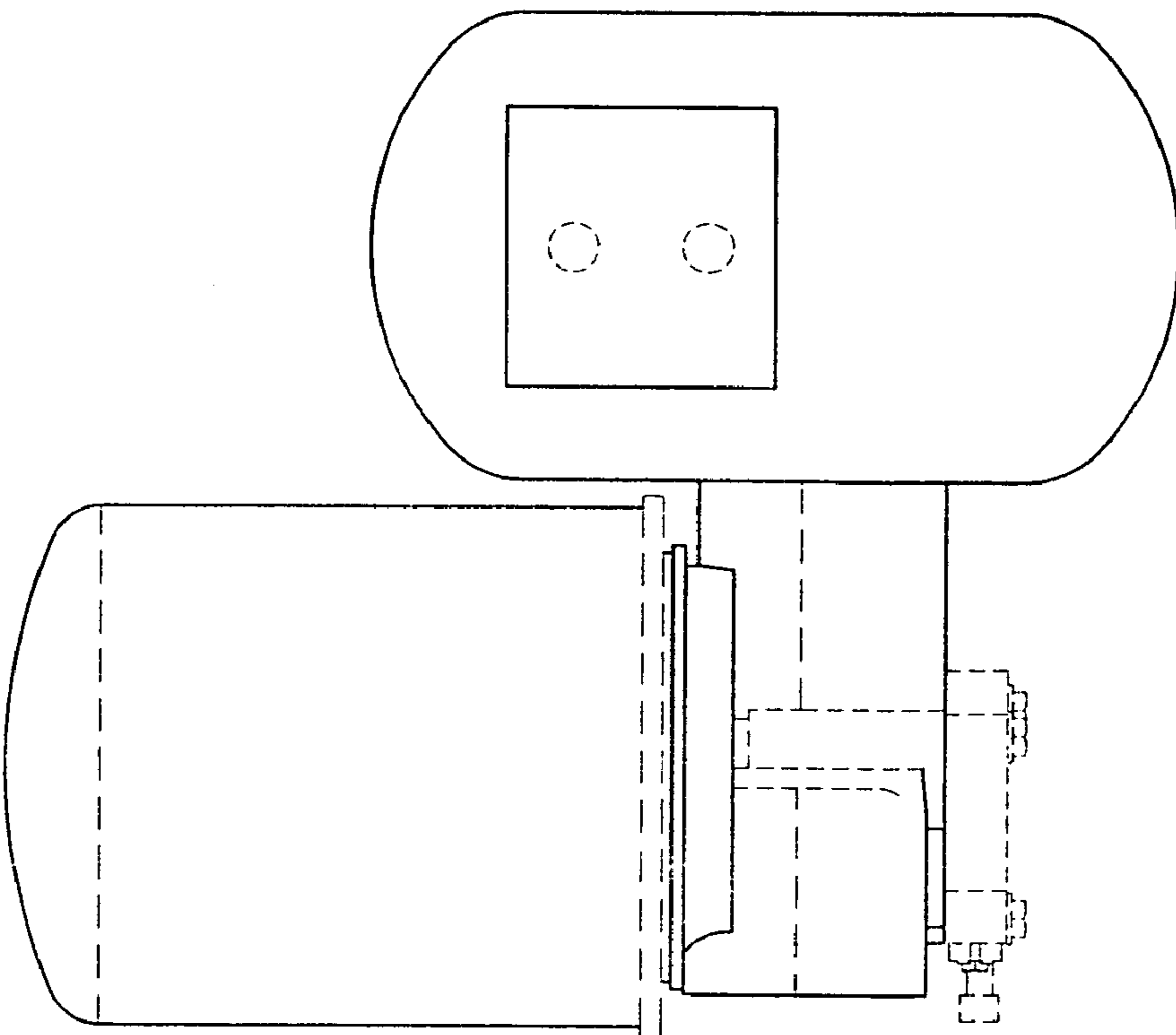

FIG. 4

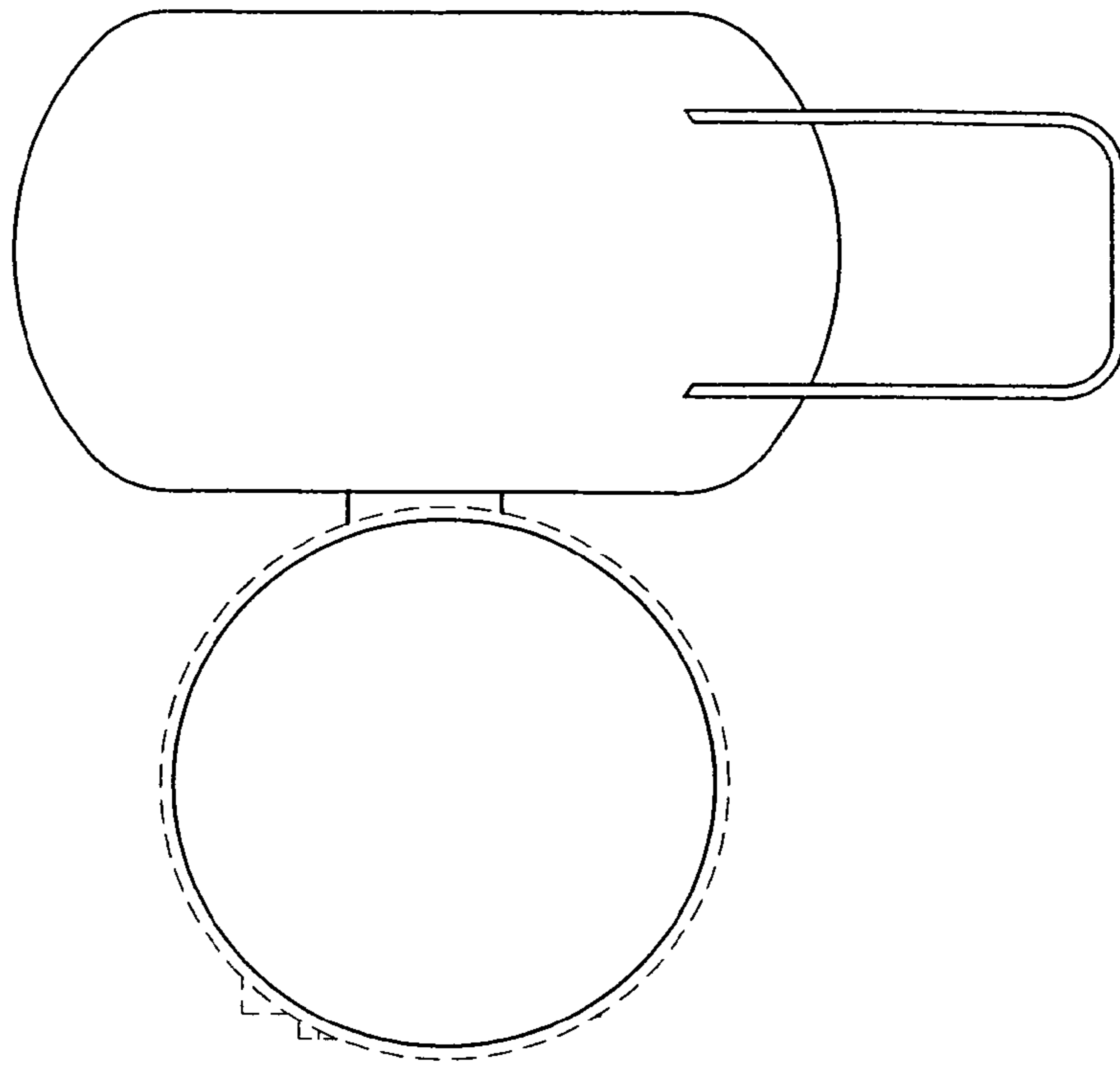

FIG. 6

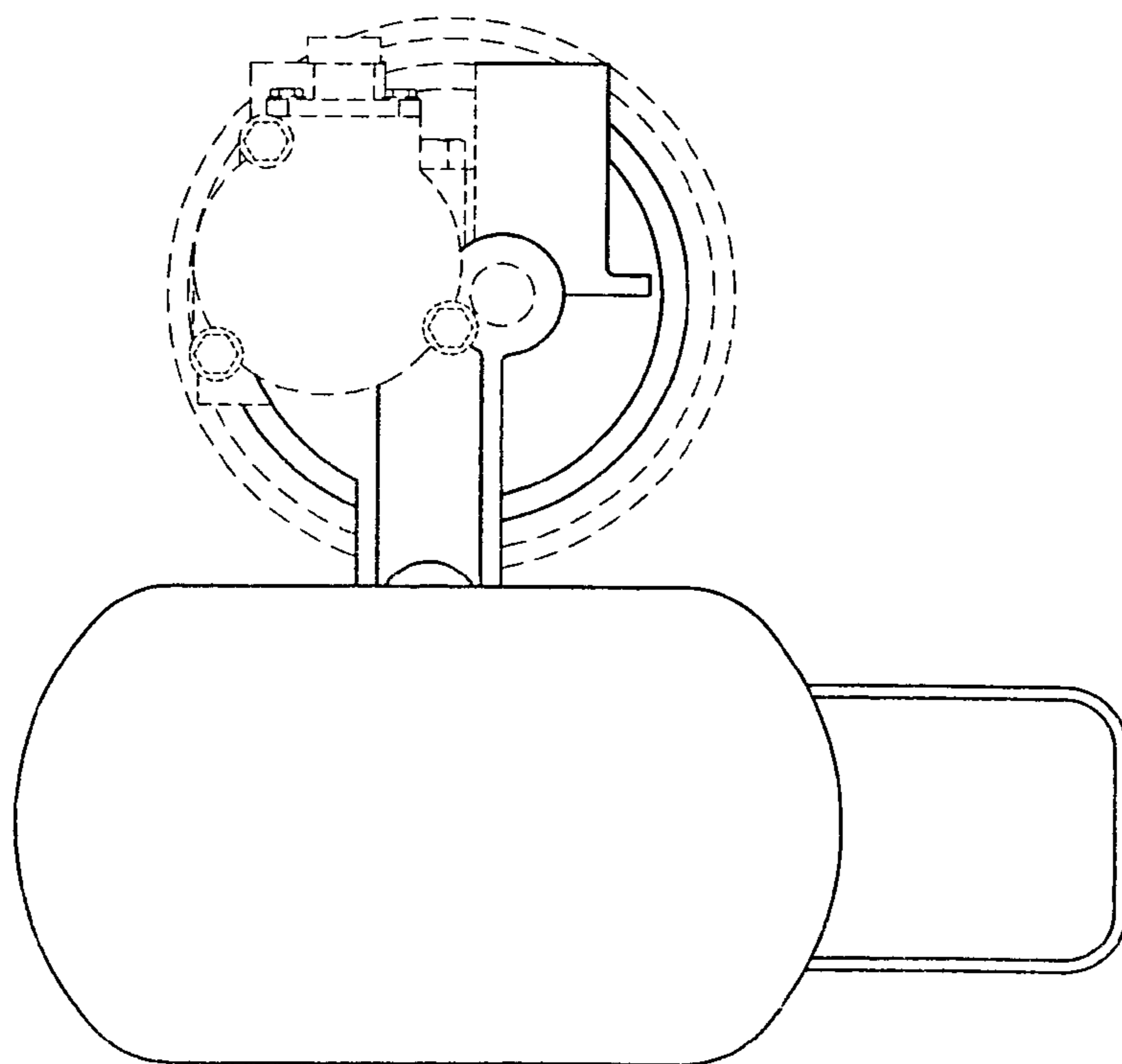

FIG. 7

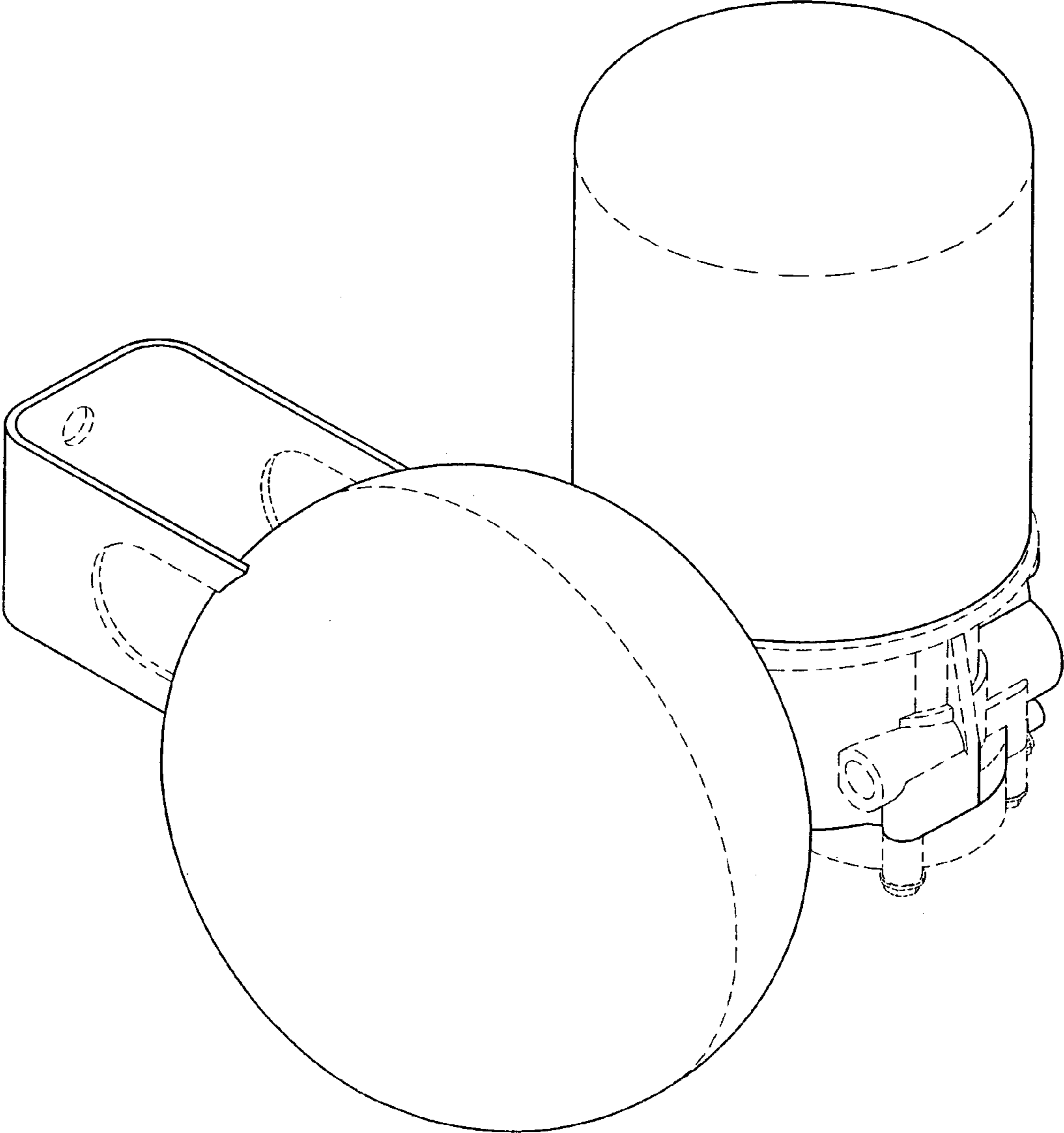

FIG. 8

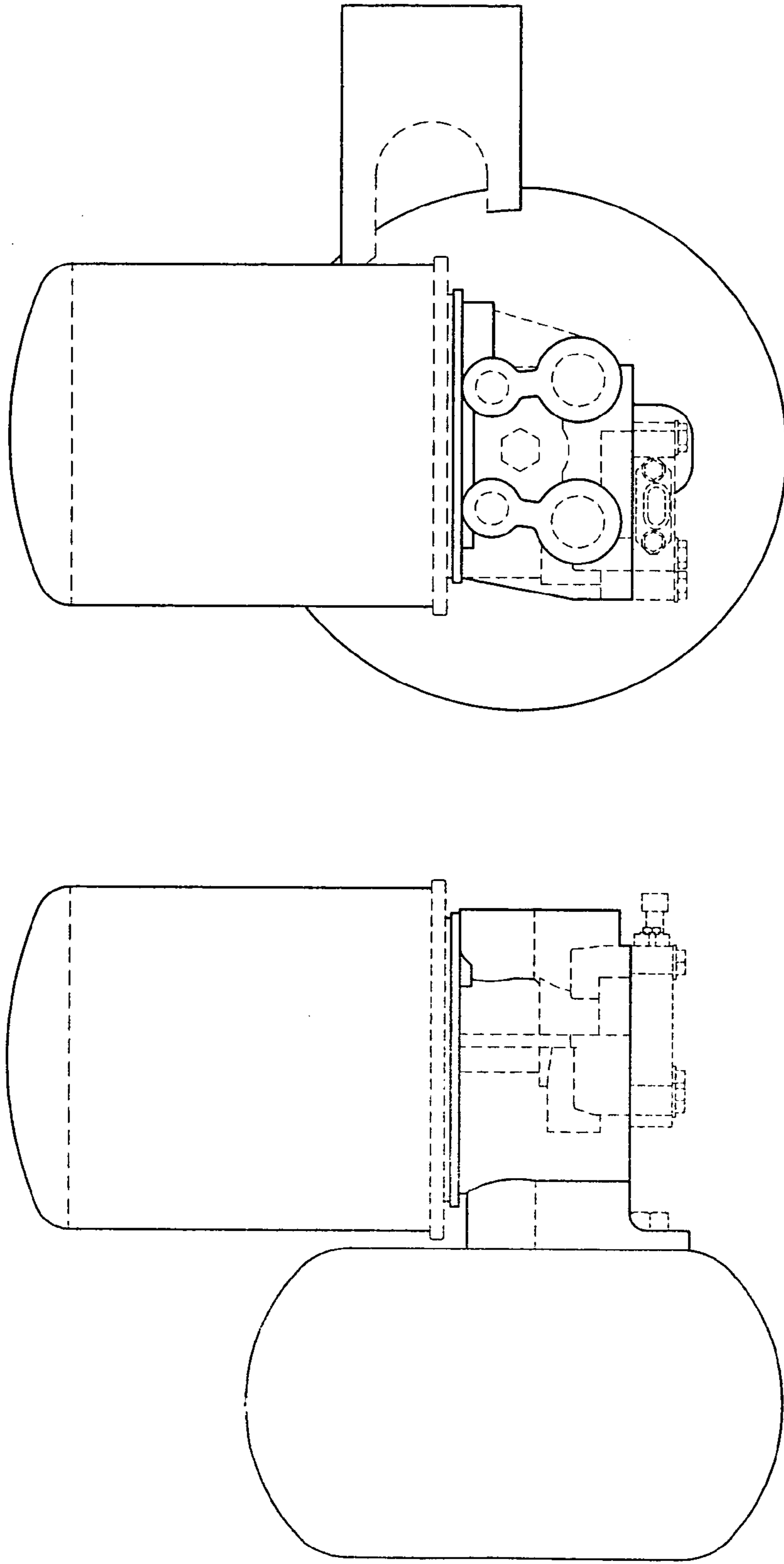

FIG. 9

FIG. 10

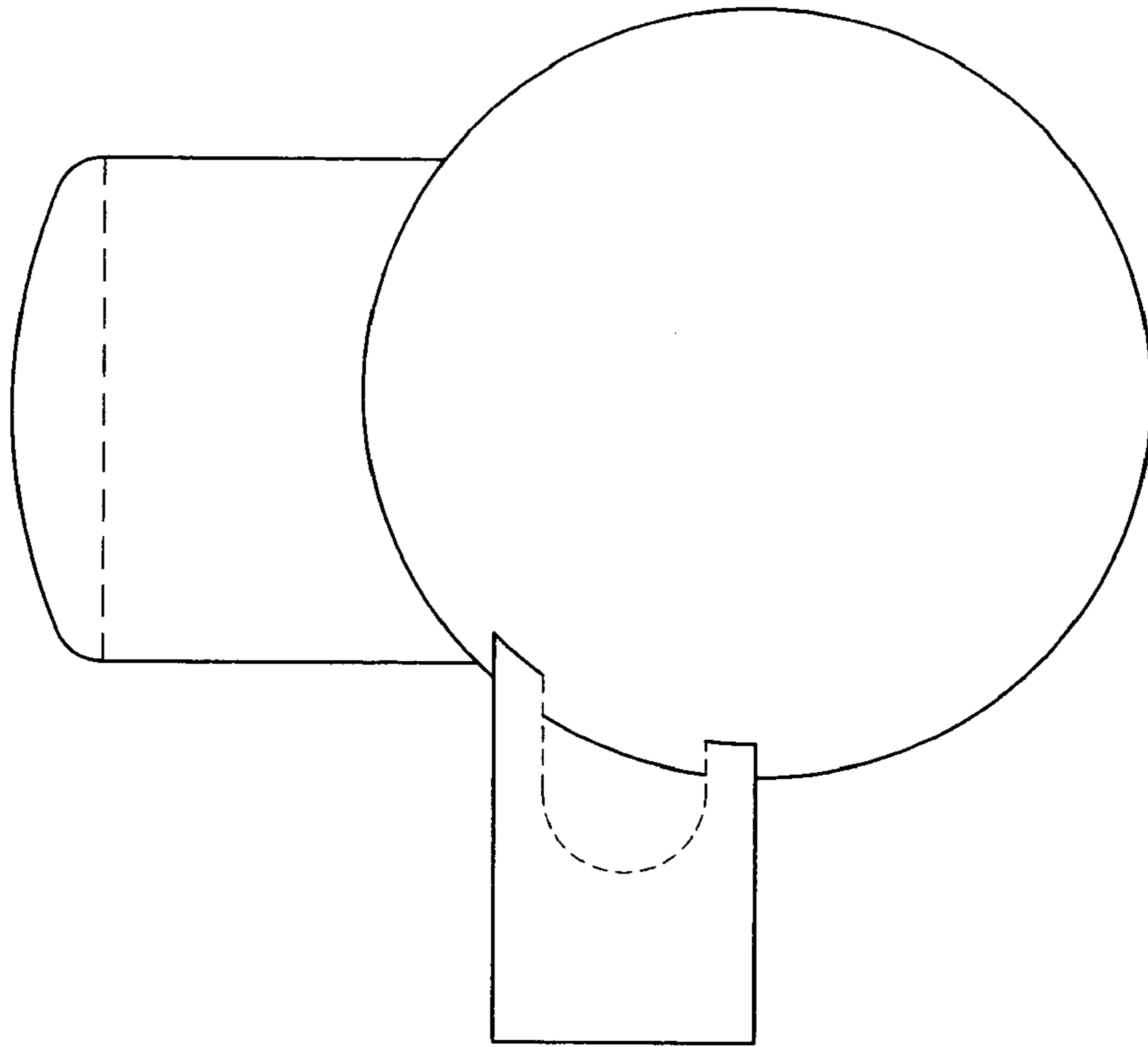

FIG. 12

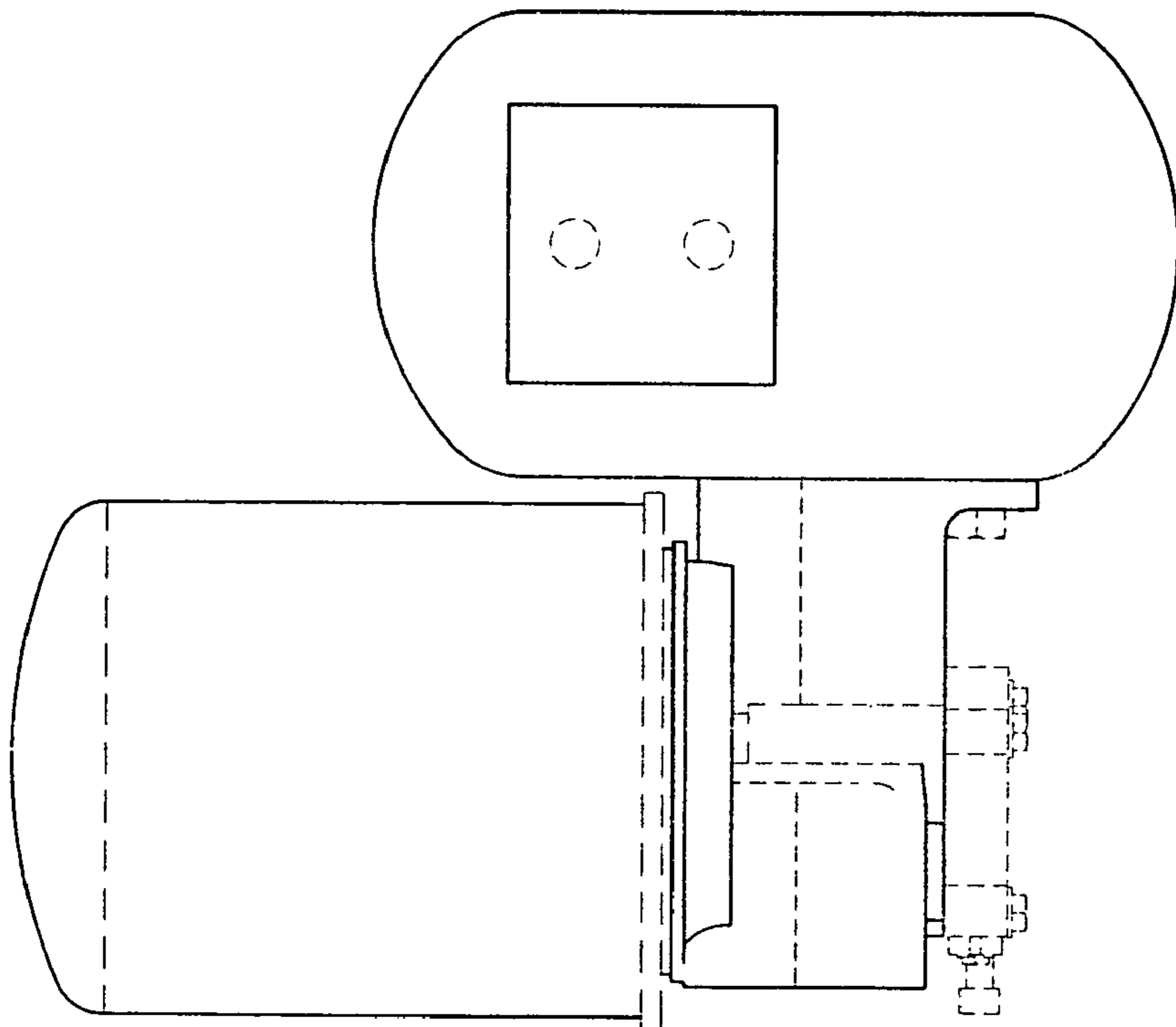

FIG. 11

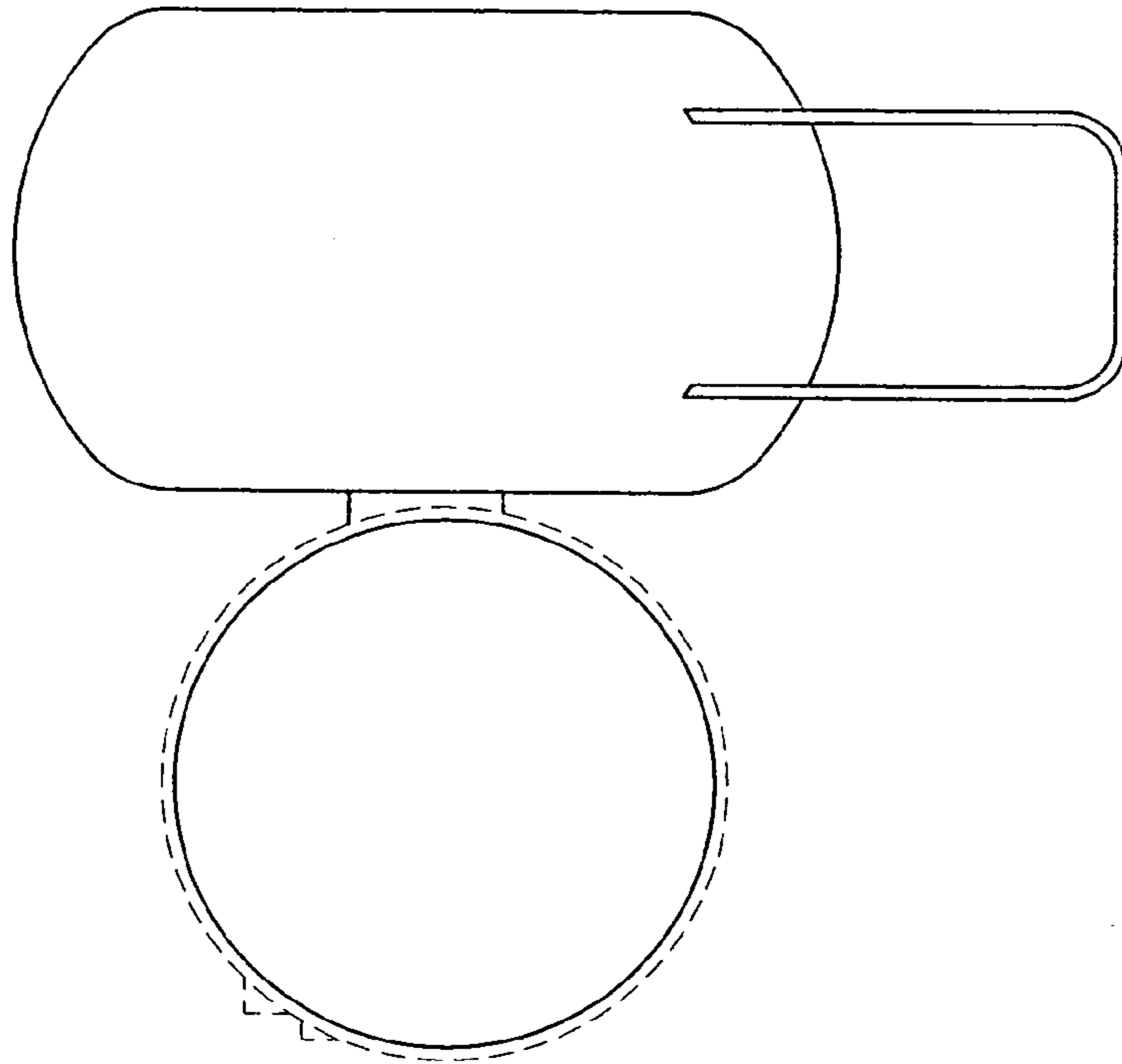

FIG. 13

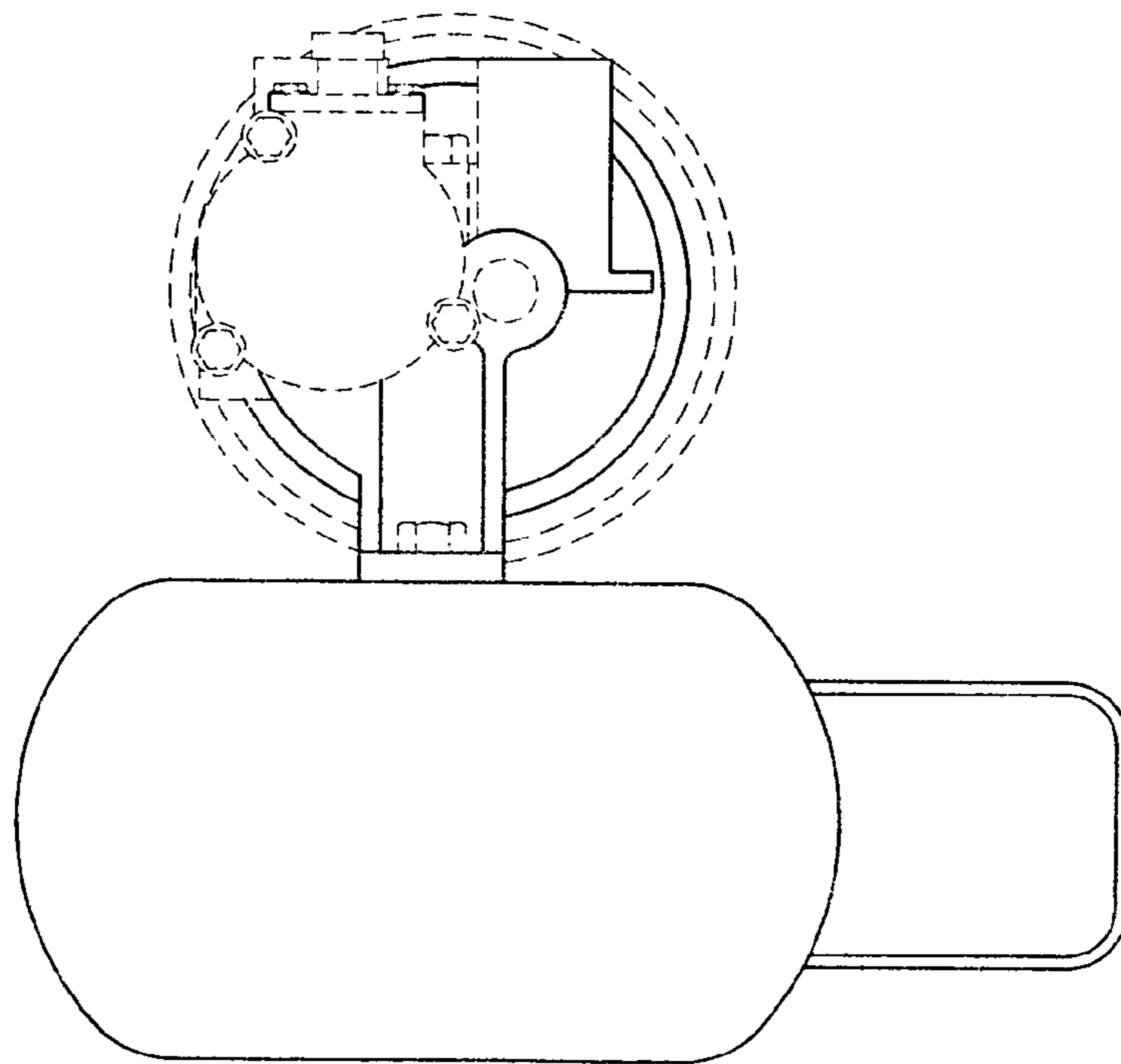

FIG. 14

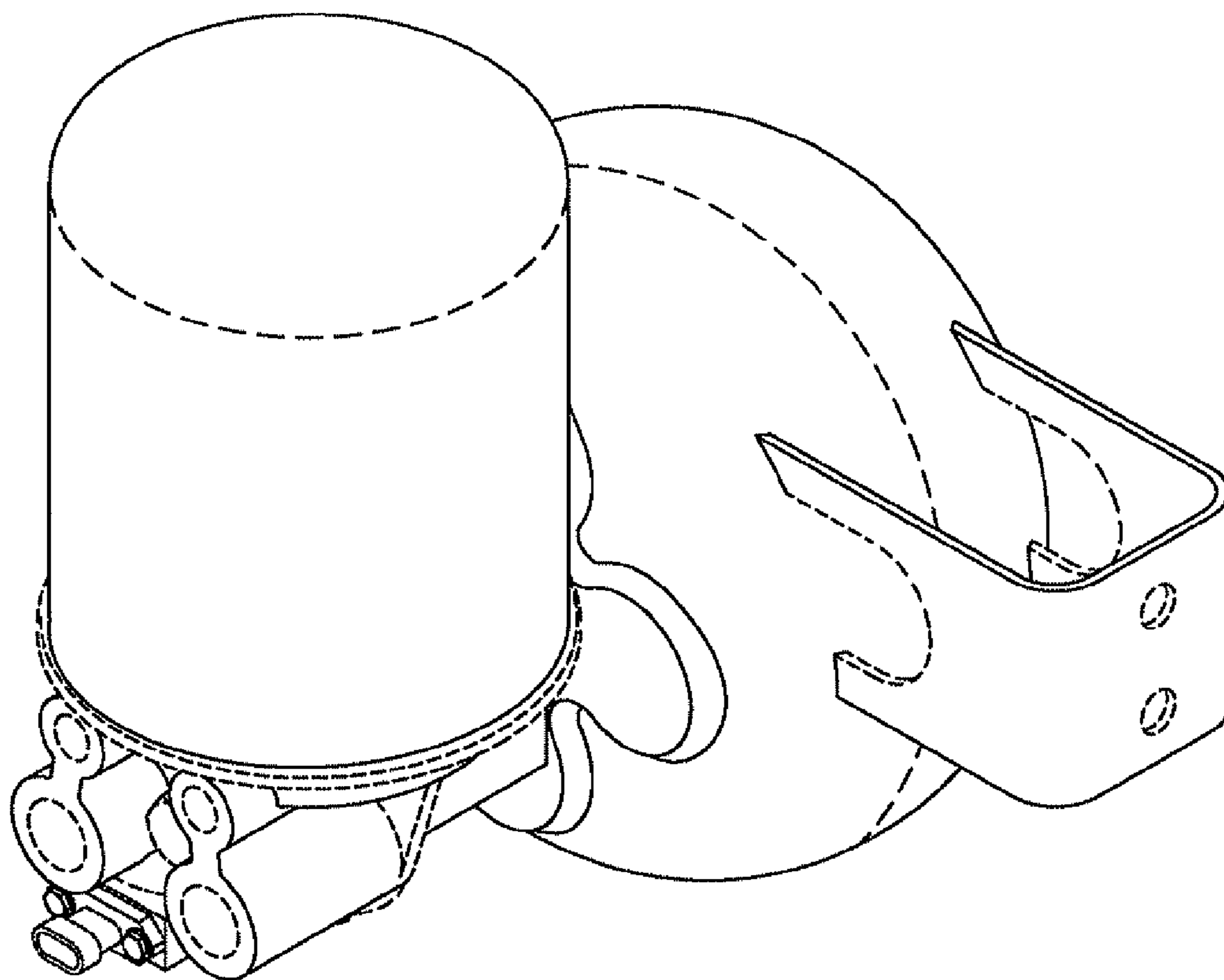

FIG. 15

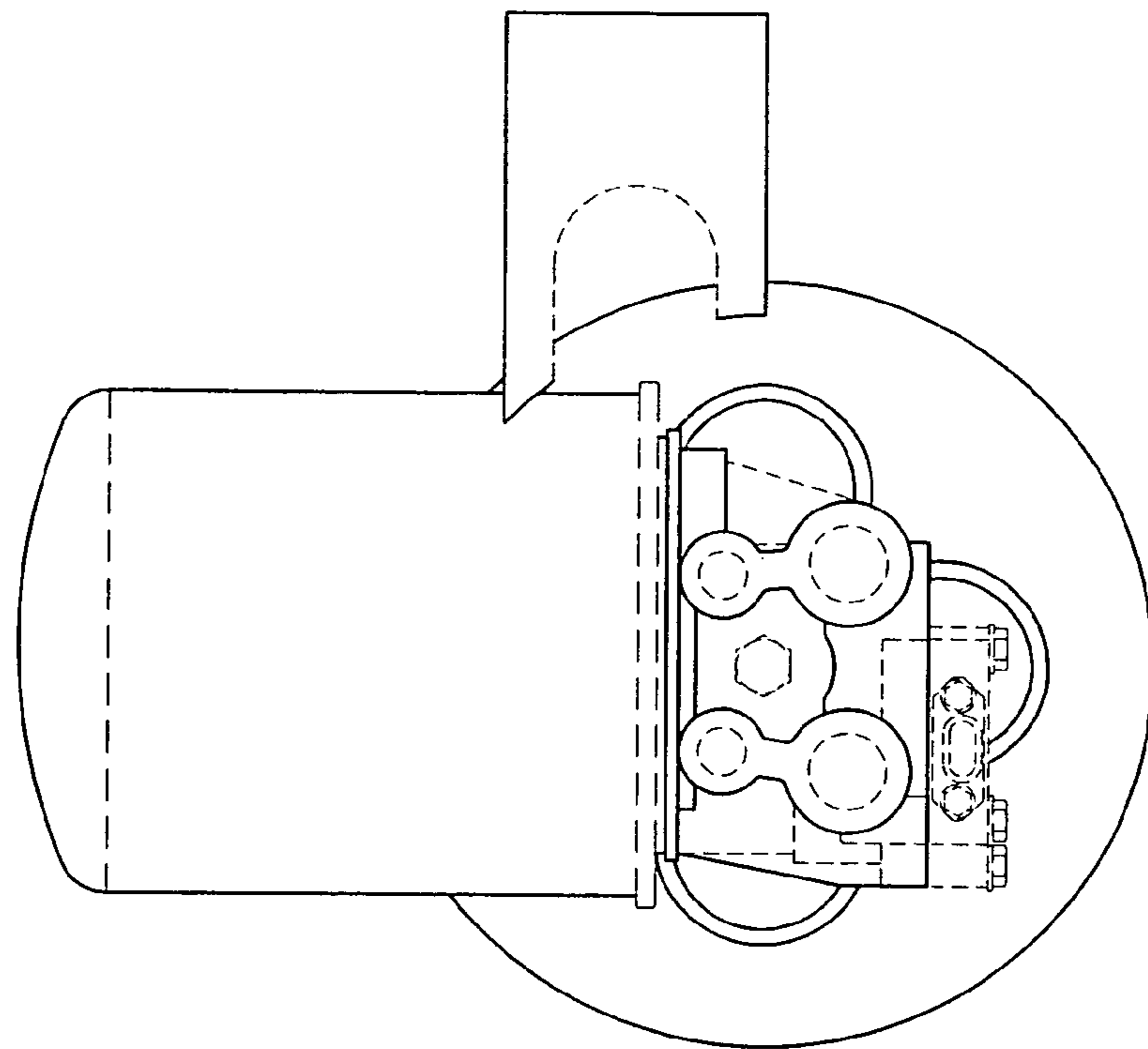

FIG. 16

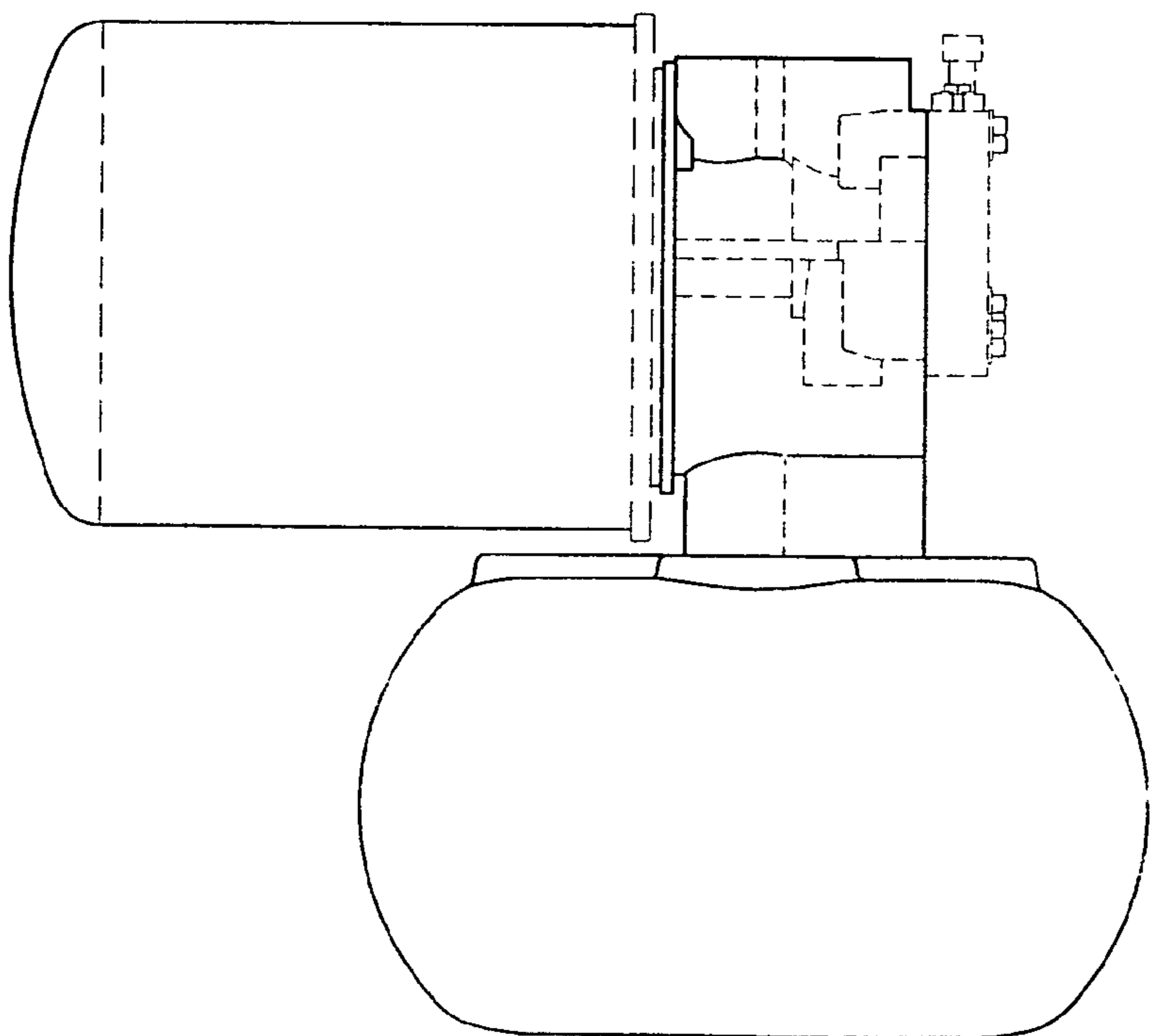

FIG. 17

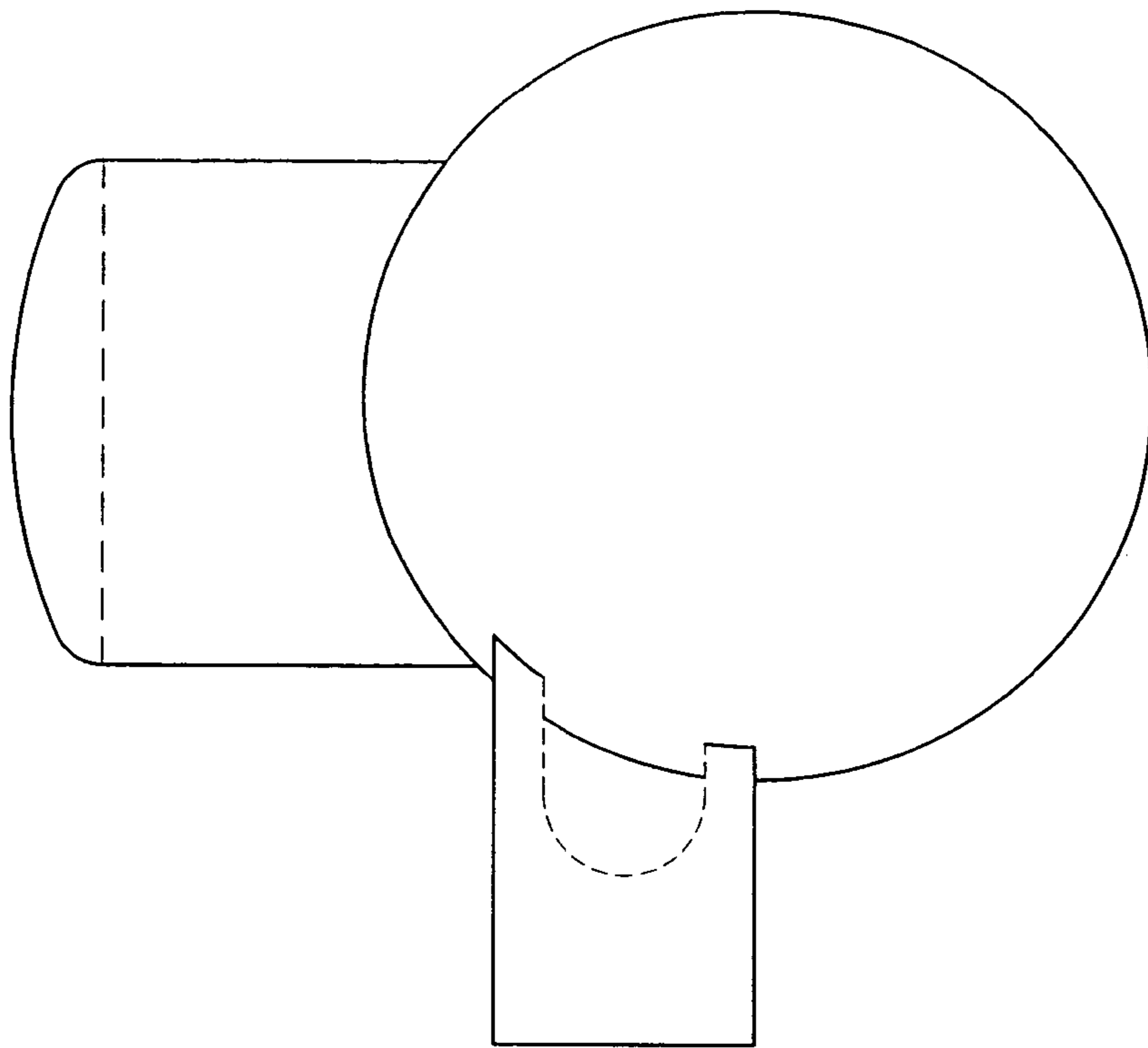

FIG. 18

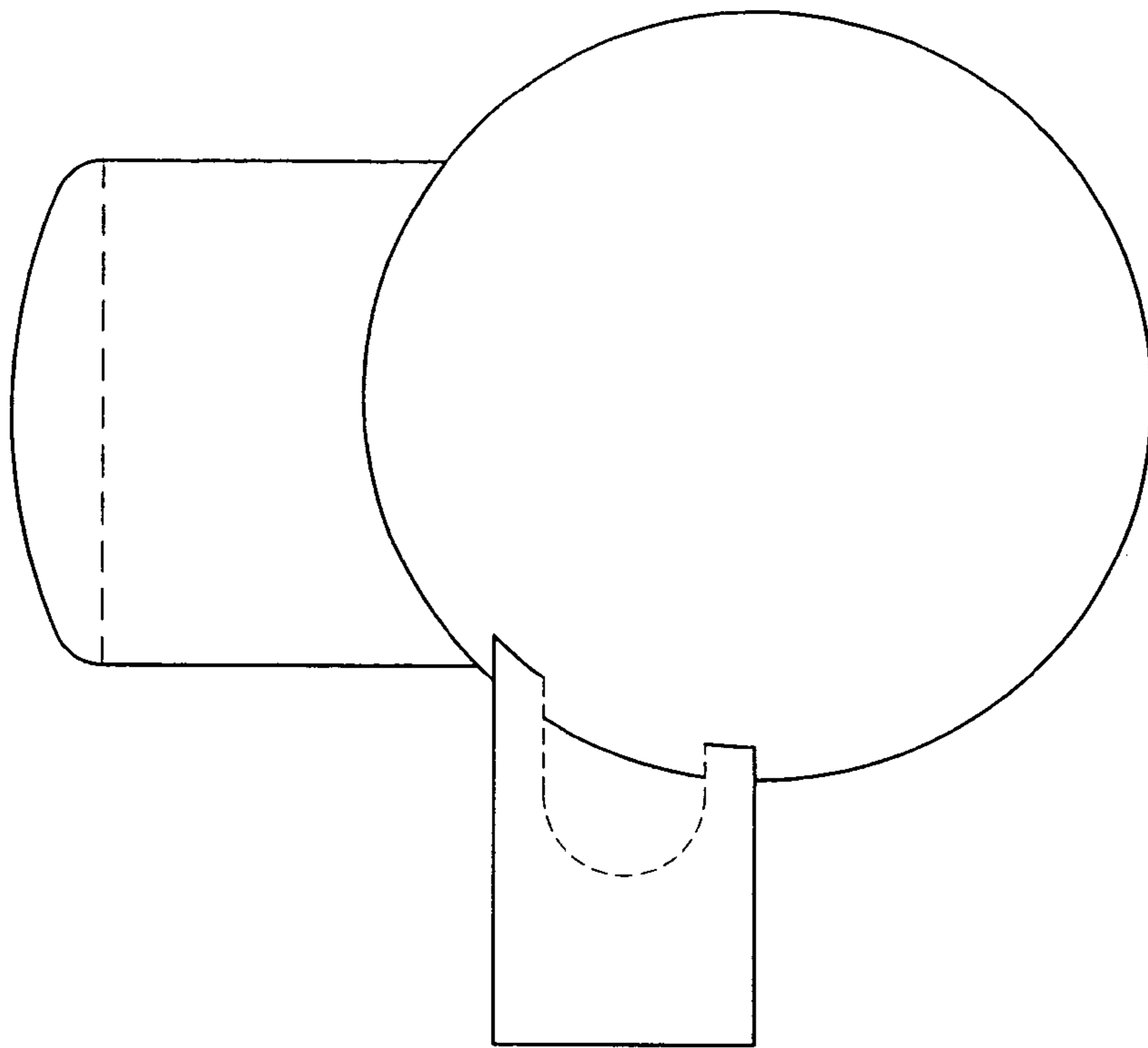

FIG. 19

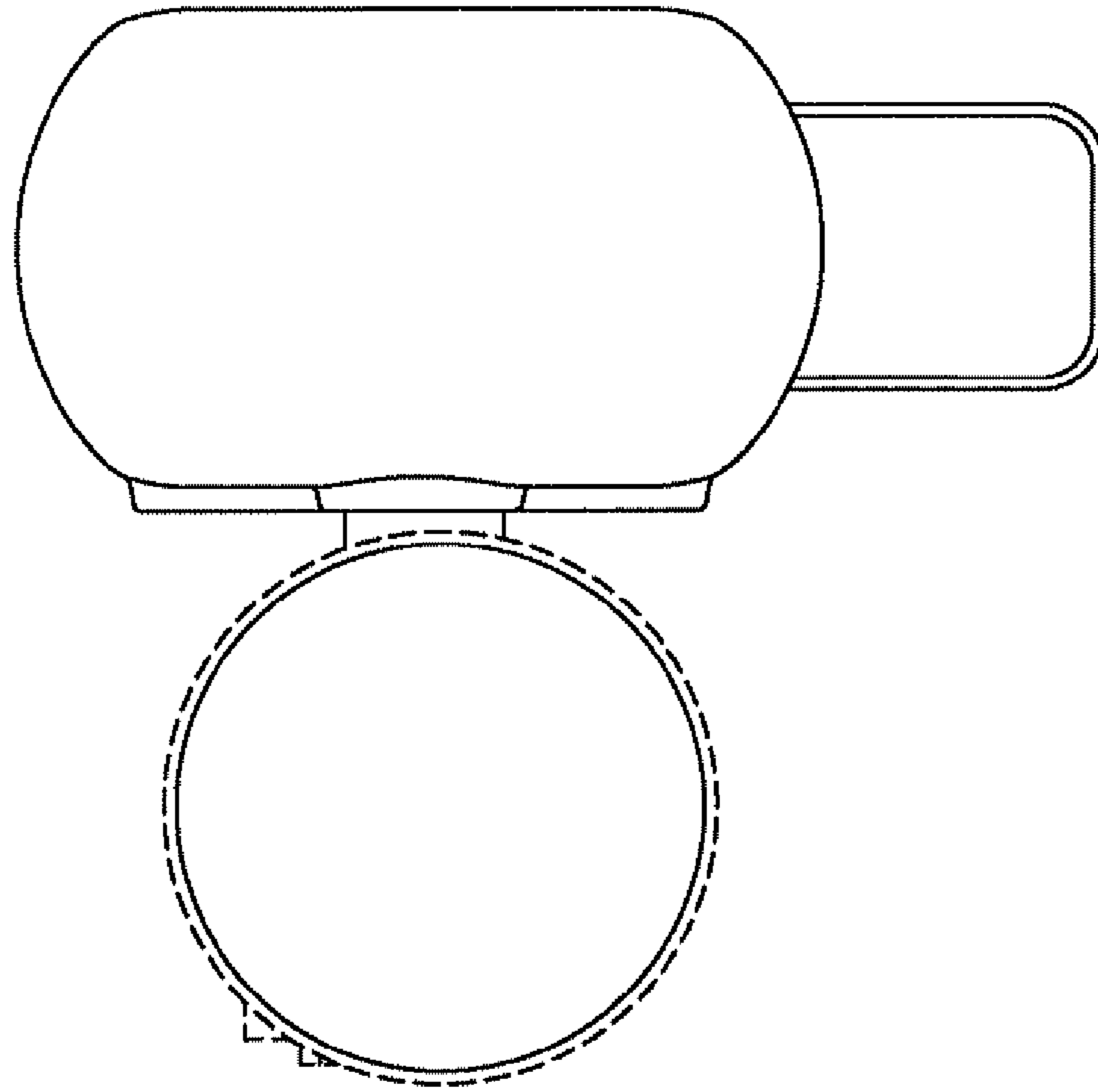

FIG. 20

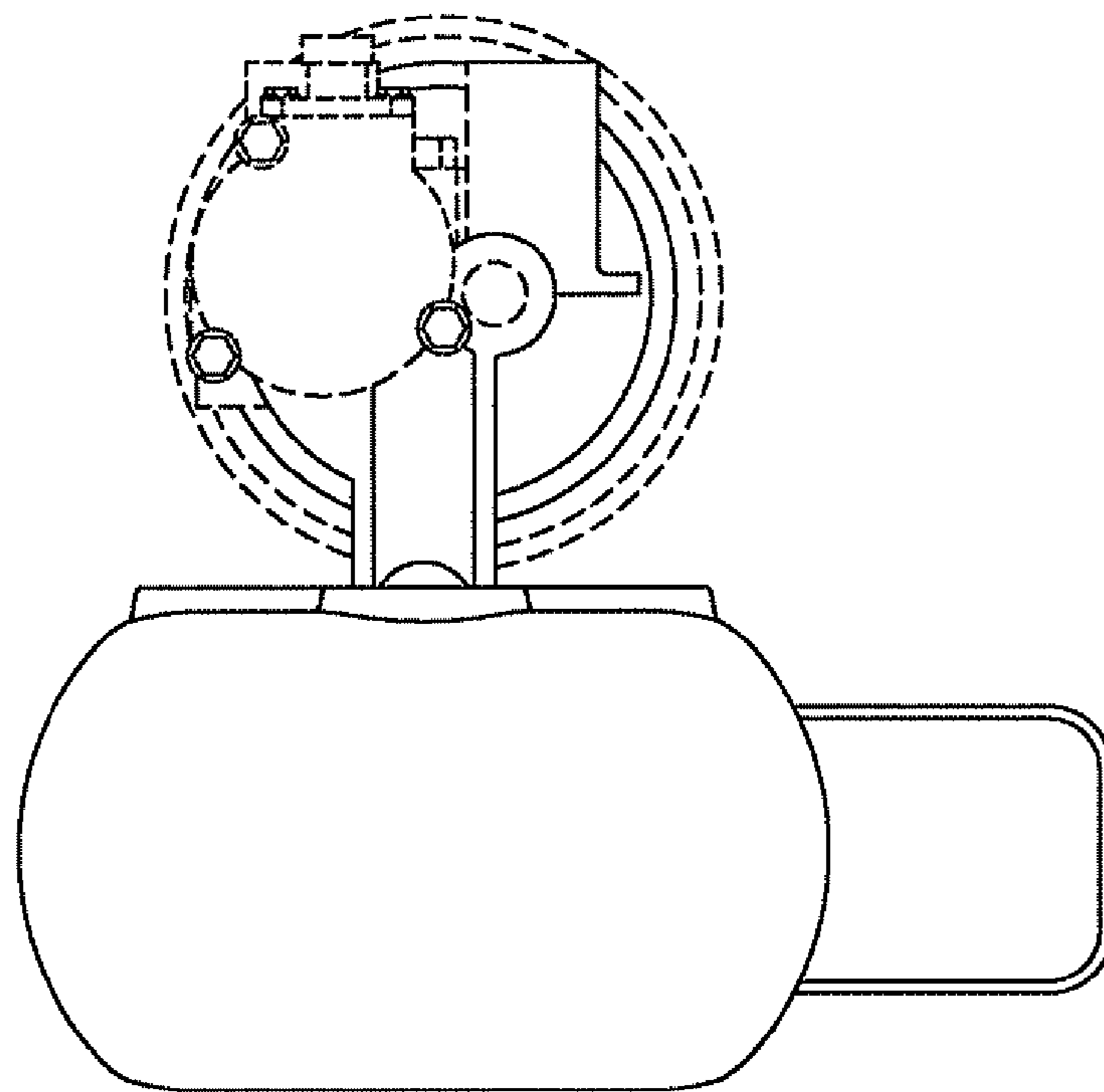

FIG. 21

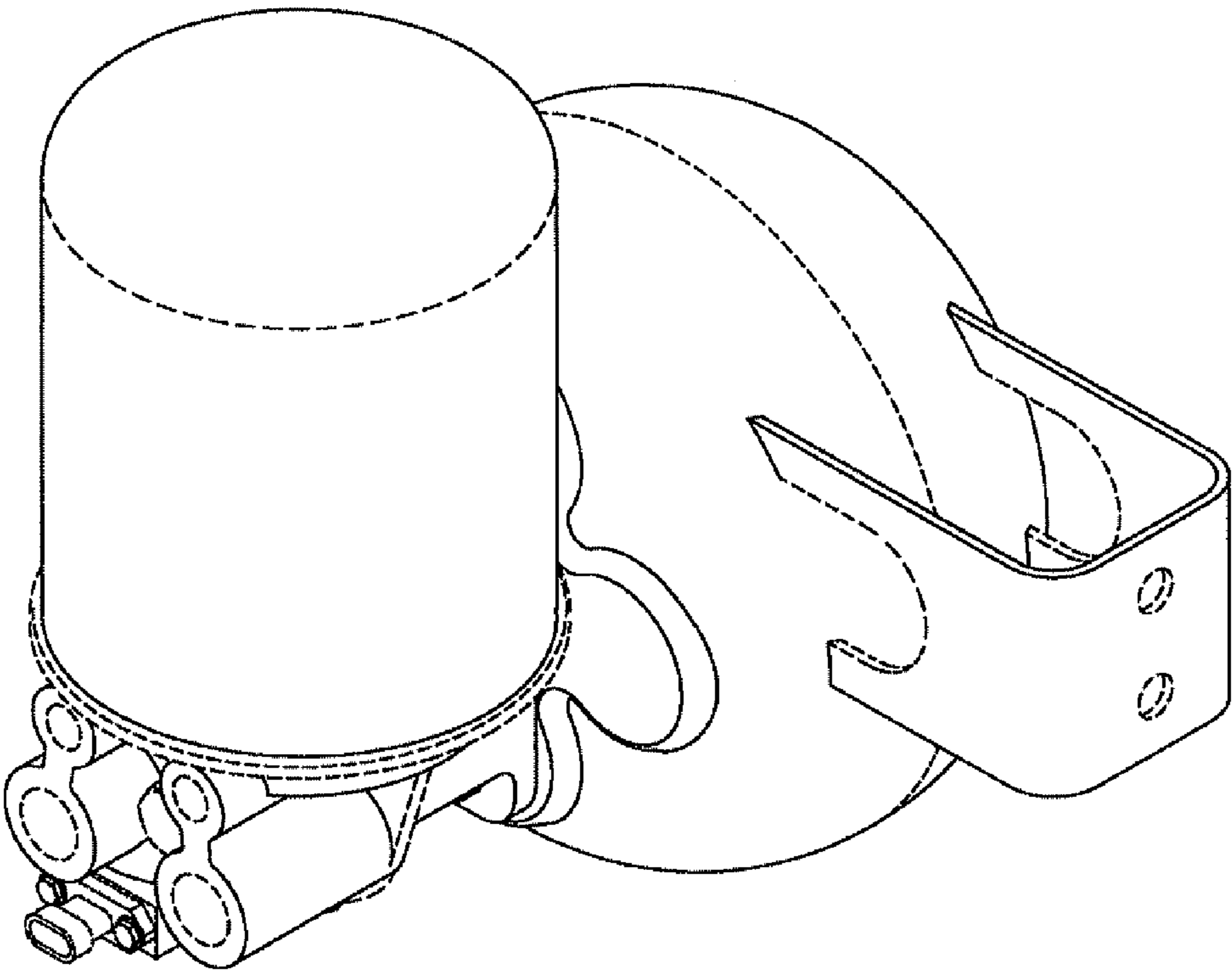

FIG. 22

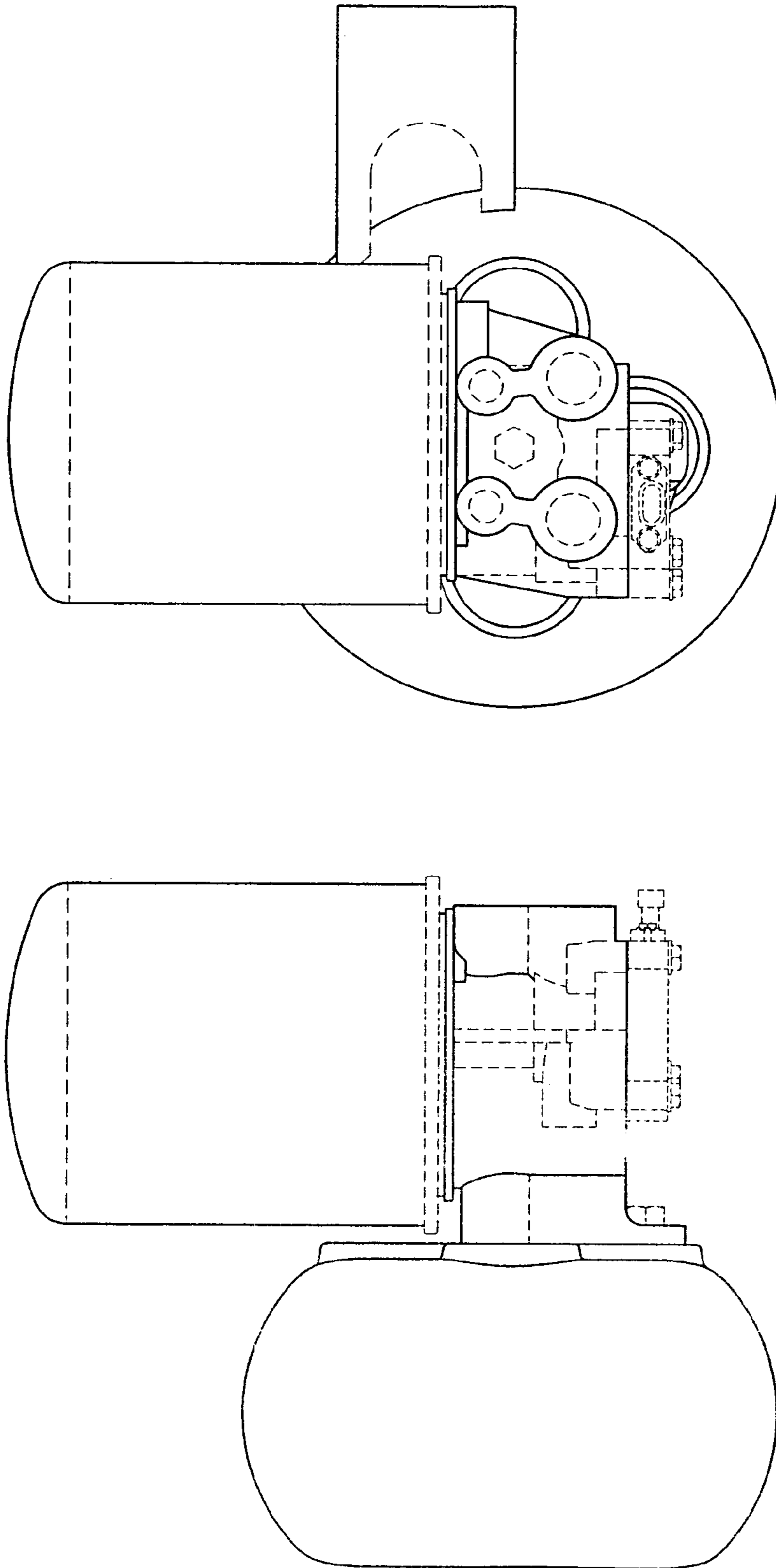

FIG. 24

FIG. 23

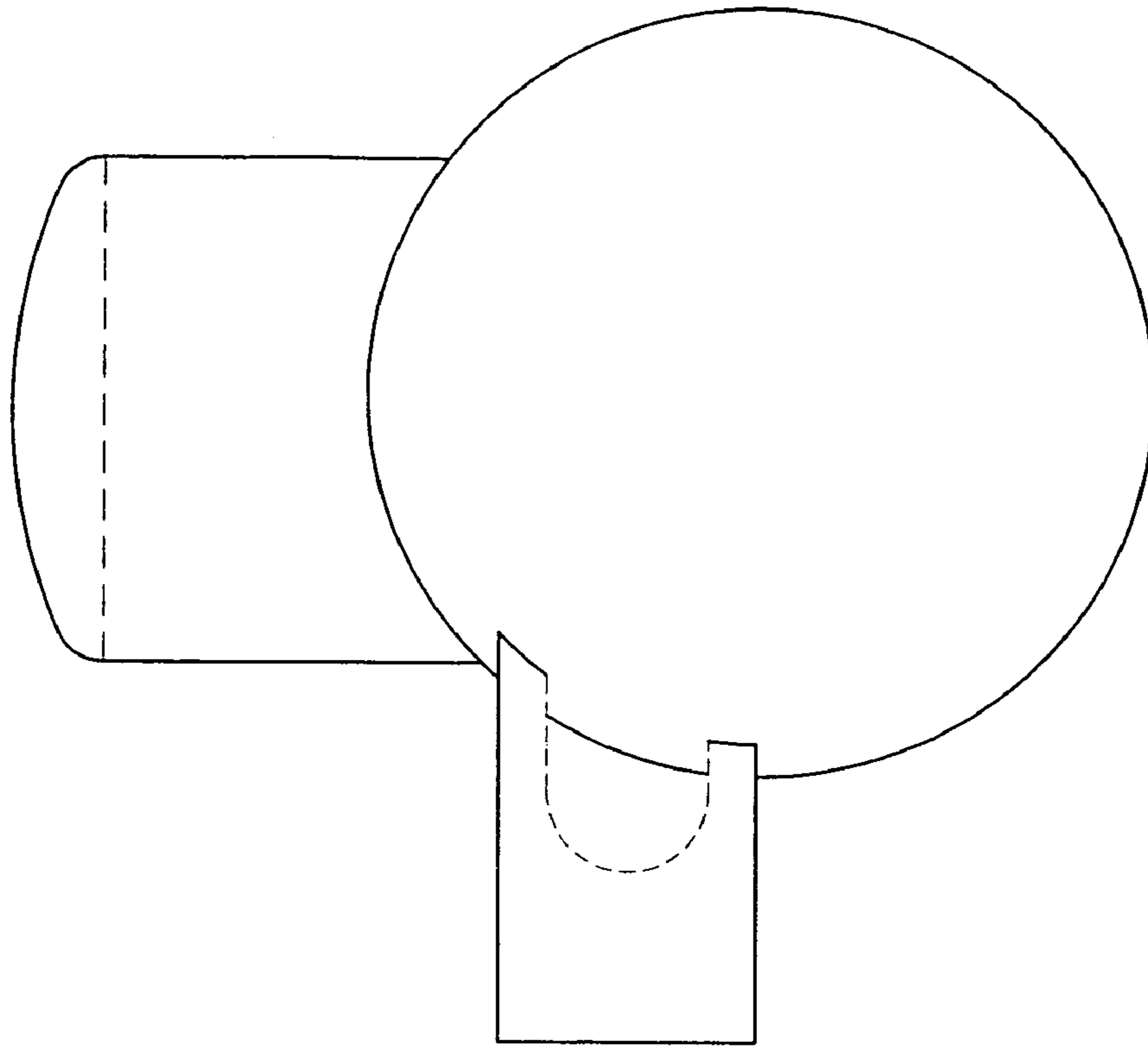

FIG. 26

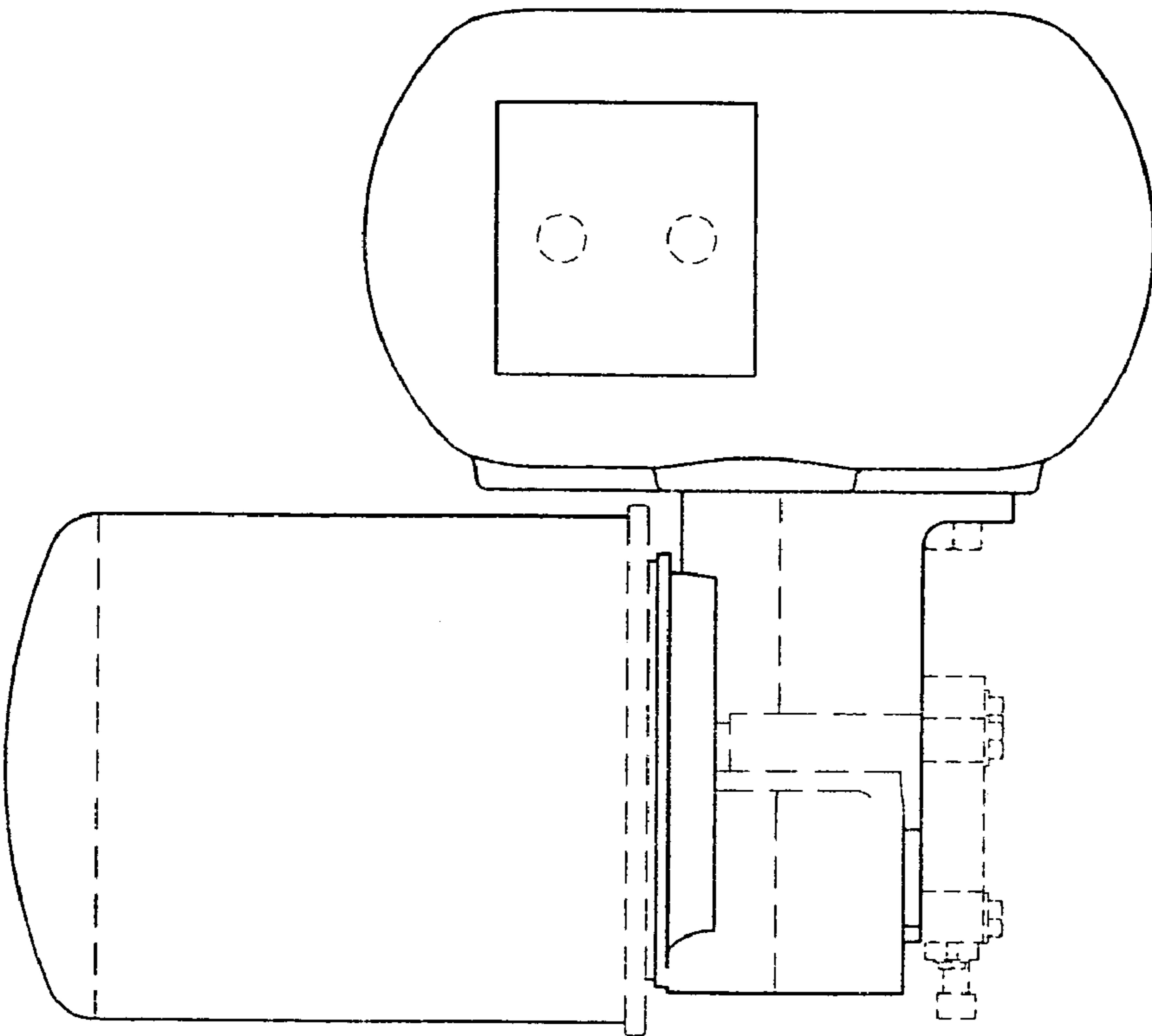

FIG. 25

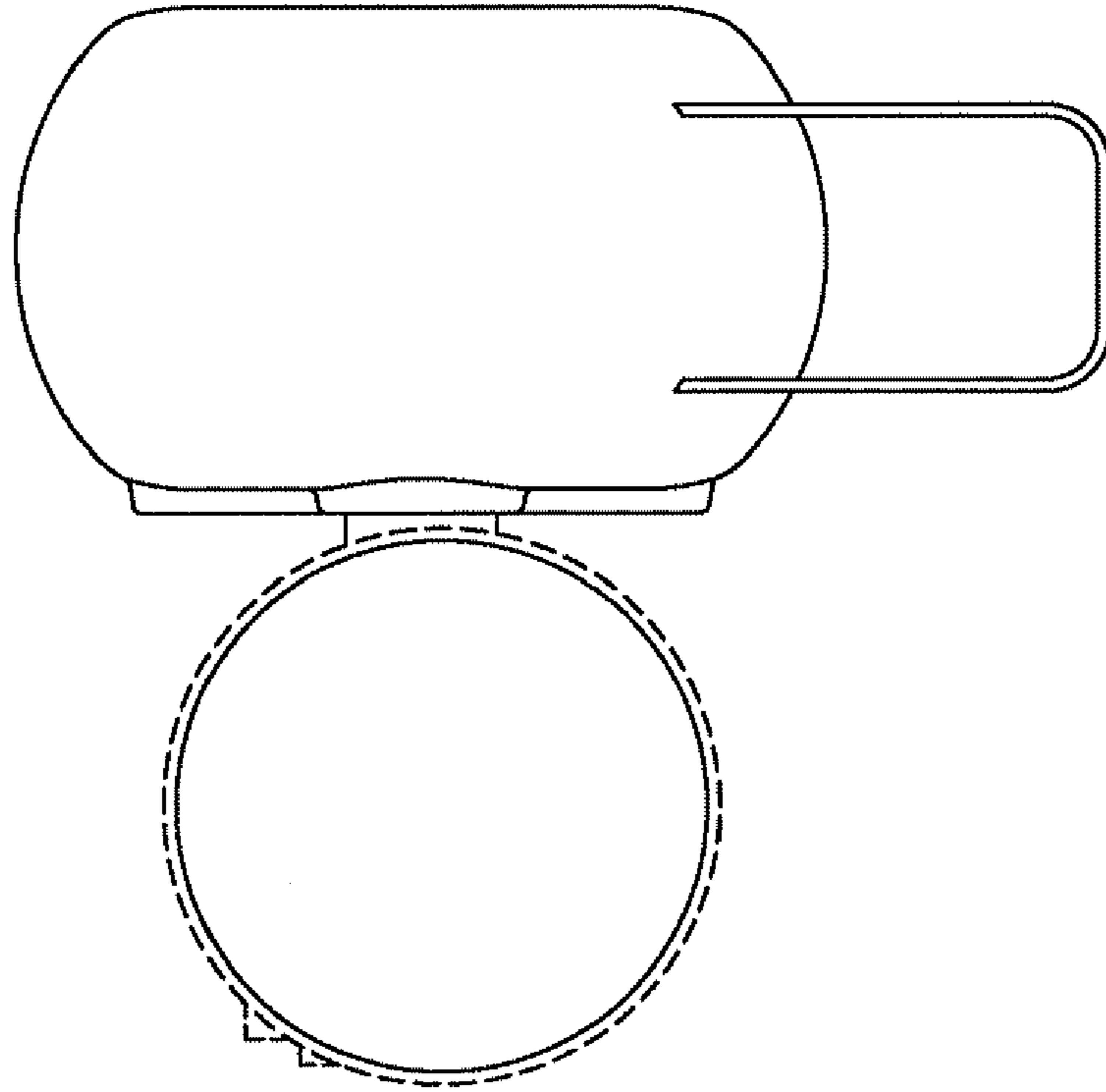

FIG. 27

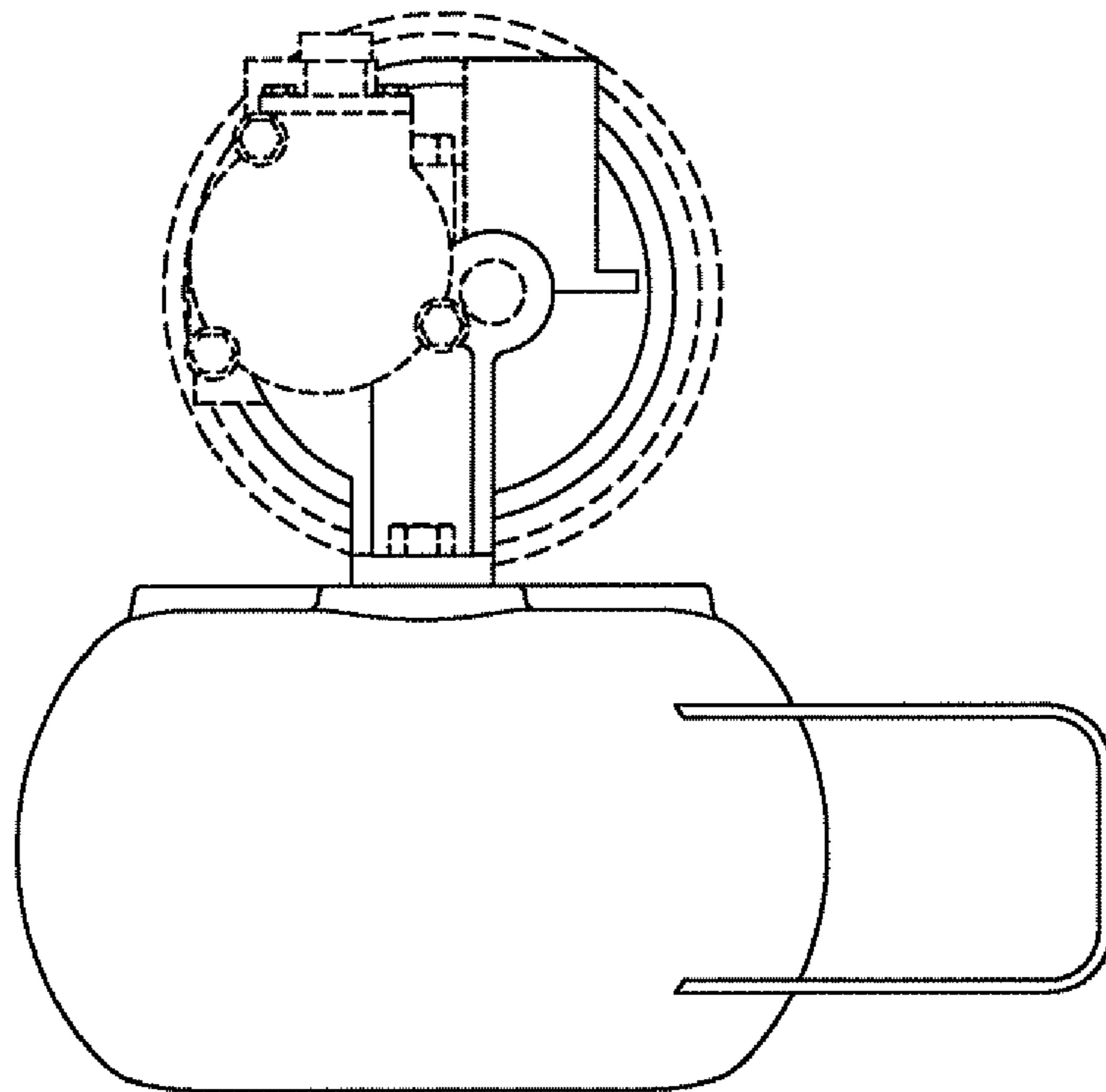

FIG. 28