



US00D573084S

(12) **United States Design Patent**
Aeberhard

(10) **Patent No.:** **US D573,084 S**
(45) **Date of Patent:** **** Jul. 15, 2008**

(54) **BOAT**
(75) Inventor: **Fabrice Aeberhard**, Affoltern am Albis
(CH)
(73) Assignee: **Code-X AG**, Meggen (CH)
(**) Term: **14 Years**
(21) Appl. No.: **29/284,905**
(22) Filed: **Sep. 18, 2007**

4,392,444 A * 7/1983 Andersson 114/126
D289,392 S * 4/1987 Gary et al. D12/304
D332,077 S * 12/1992 Parker D12/310
D474,730 S * 5/2003 Flaherty D12/300

* cited by examiner

Primary Examiner—Holly H. Baynham
Assistant Examiner—Cynthia M Chin
(74) *Attorney, Agent, or Firm*—Dennison, Schultz &
MacDonald

(30) **Foreign Application Priority Data**
Mar. 21, 2007 (EM) 000700430
(51) **LOC (8) Cl.** **12-06**
(52) **U.S. Cl.** **D12/300**
(58) **Field of Classification Search** D12/300,
D12/303, 304, 310–314, 316–318; 114/61.1,
114/61.12, 61.2, 61.32, 126, 288–291, 352,
114/355–357
See application file for complete search history.

(57) **CLAIM**

The ornamental design for a boat, as shown and described.

DESCRIPTION

FIG. 1 is a top, front right side perspective view of a boat showing my new design;
FIG. 2 is a bottom, rear right side perspective view thereof;
FIG. 3 is a right side view thereof;
FIG. 4 is a top plan view thereof;
FIG. 5 is a bottom plan view thereof;
FIG. 6 is a front view thereof; and,
FIG. 7 is a rear view thereof.

(56) **References Cited**
U.S. PATENT DOCUMENTS
3,139,058 A * 6/1964 Robinson 114/352

1 Claim, 2 Drawing Sheets

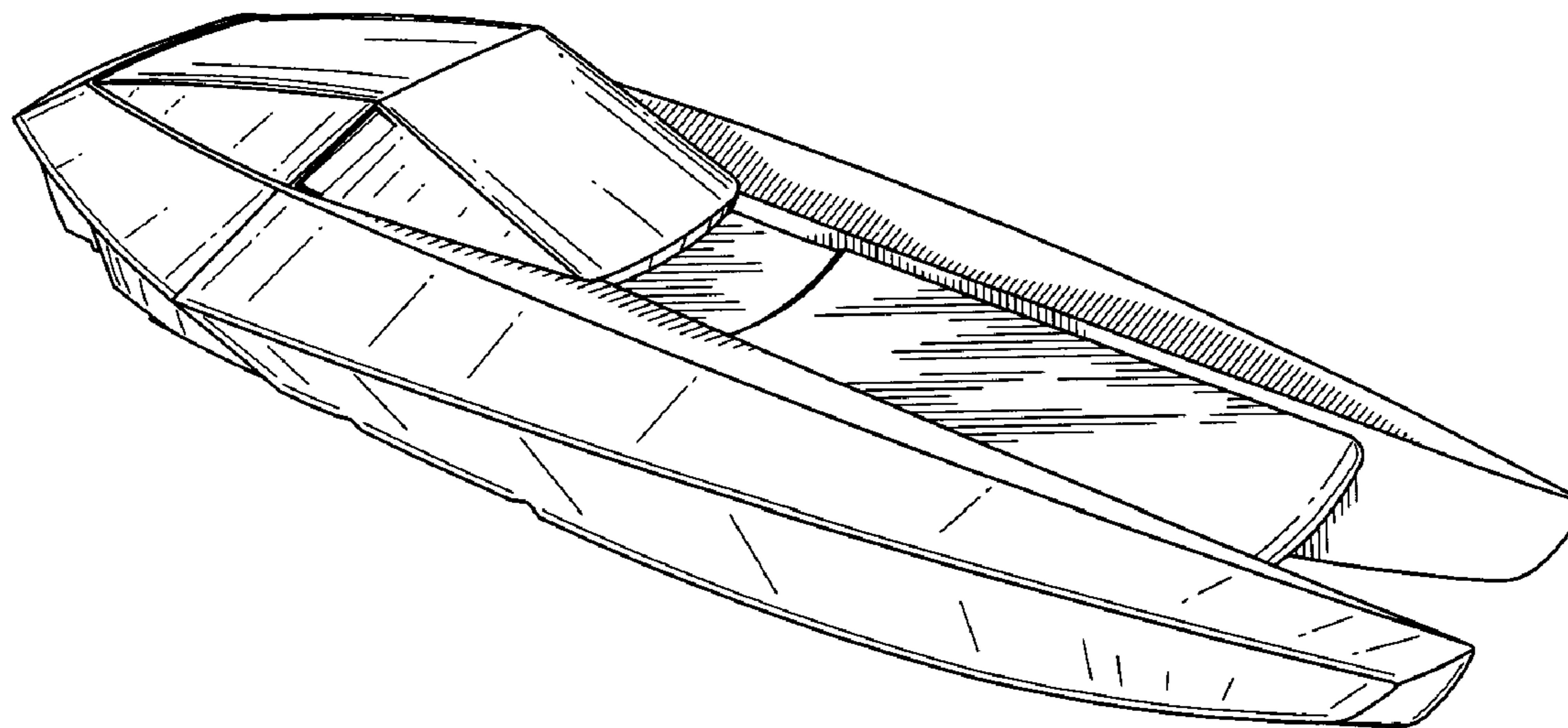

FIG. 1

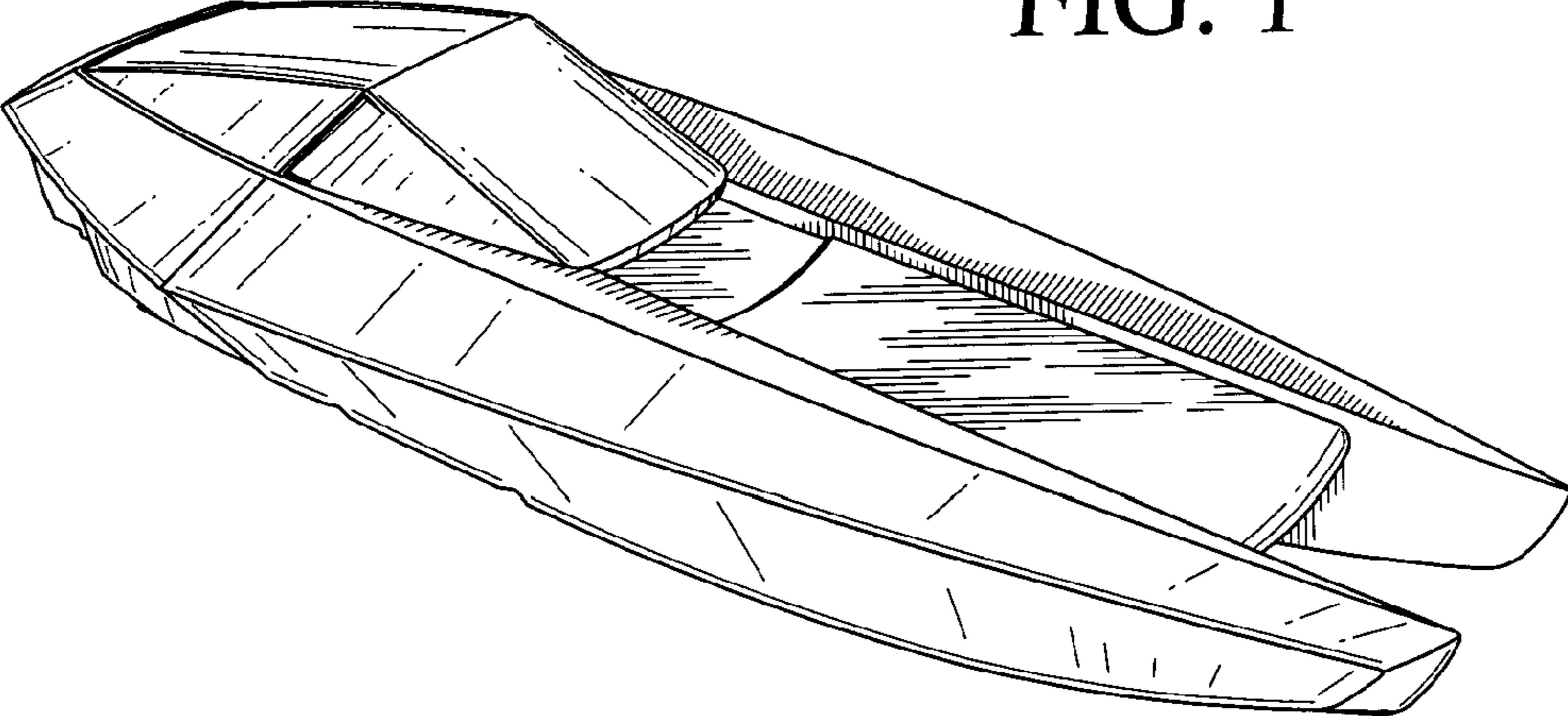

FIG. 2

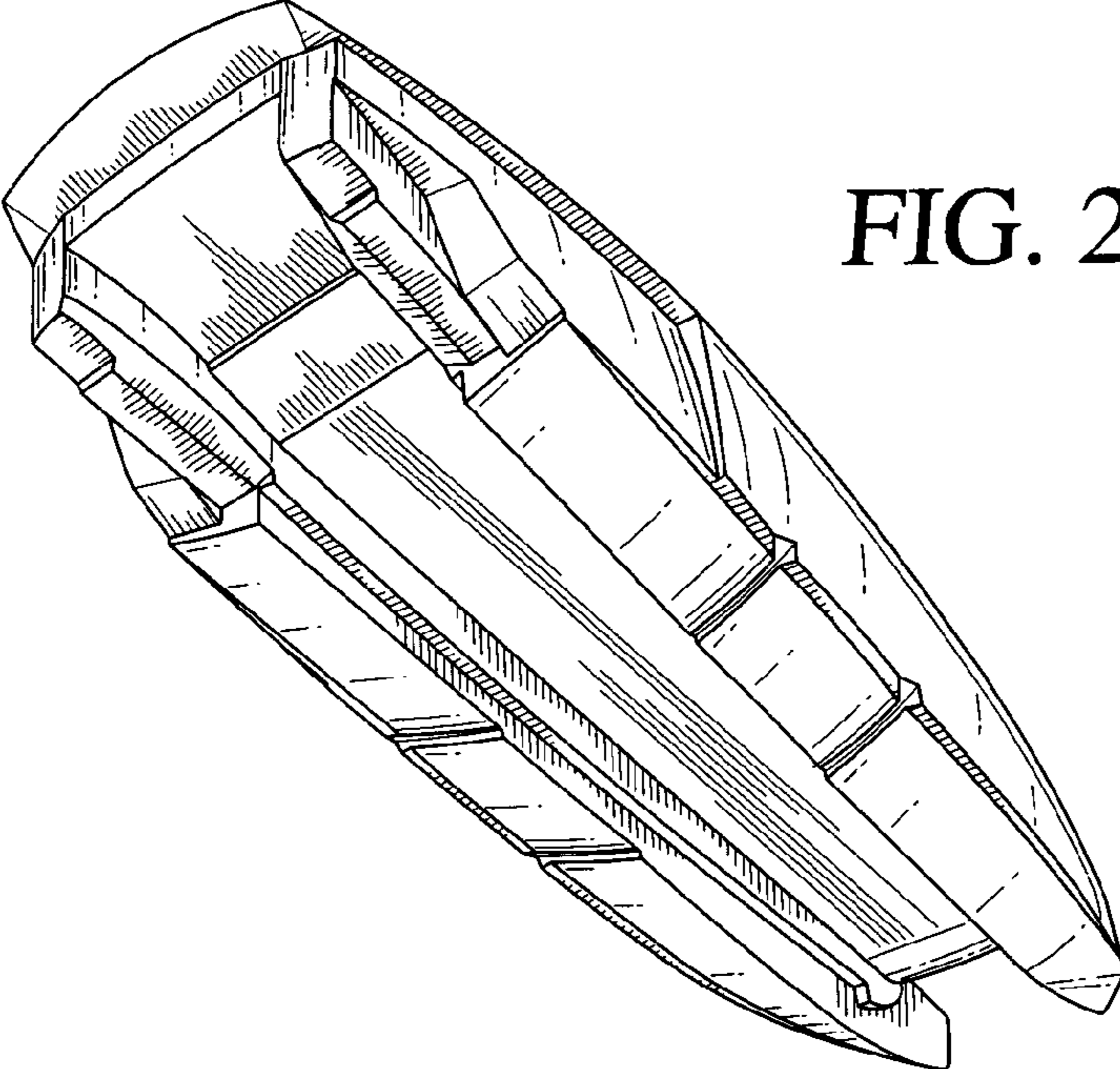
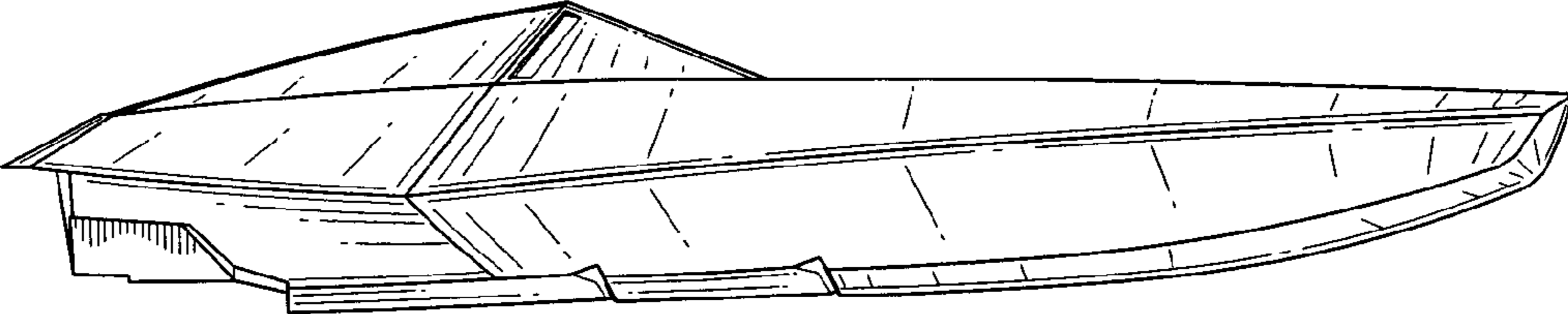

FIG. 3



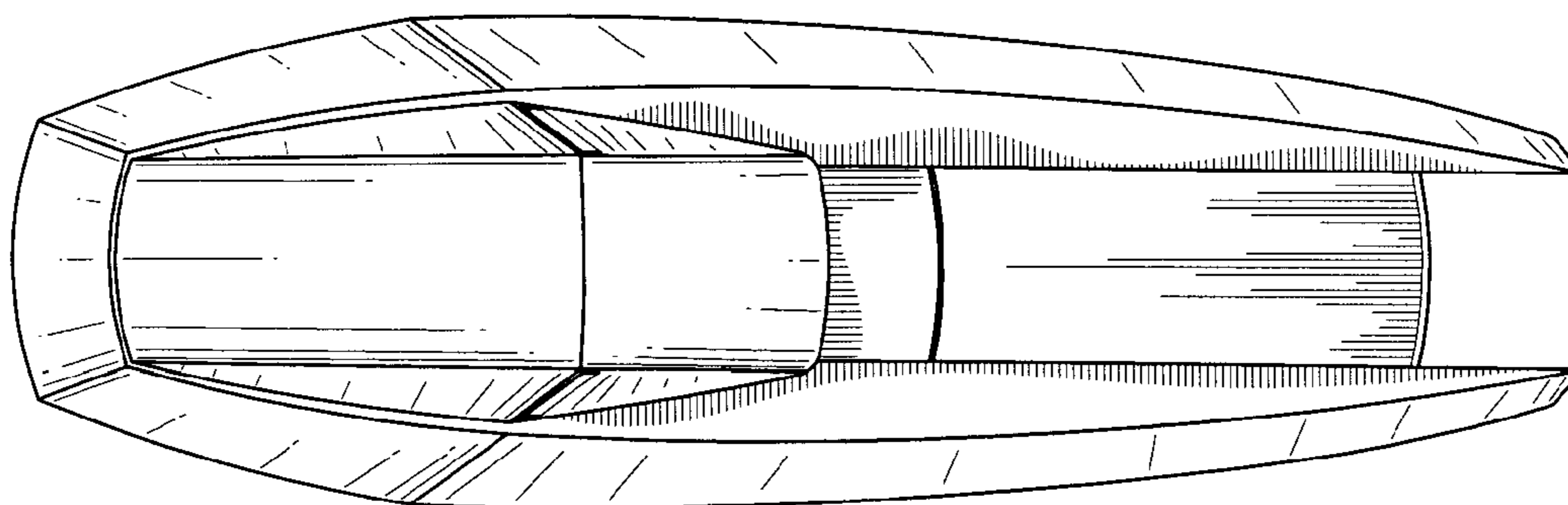

FIG. 4

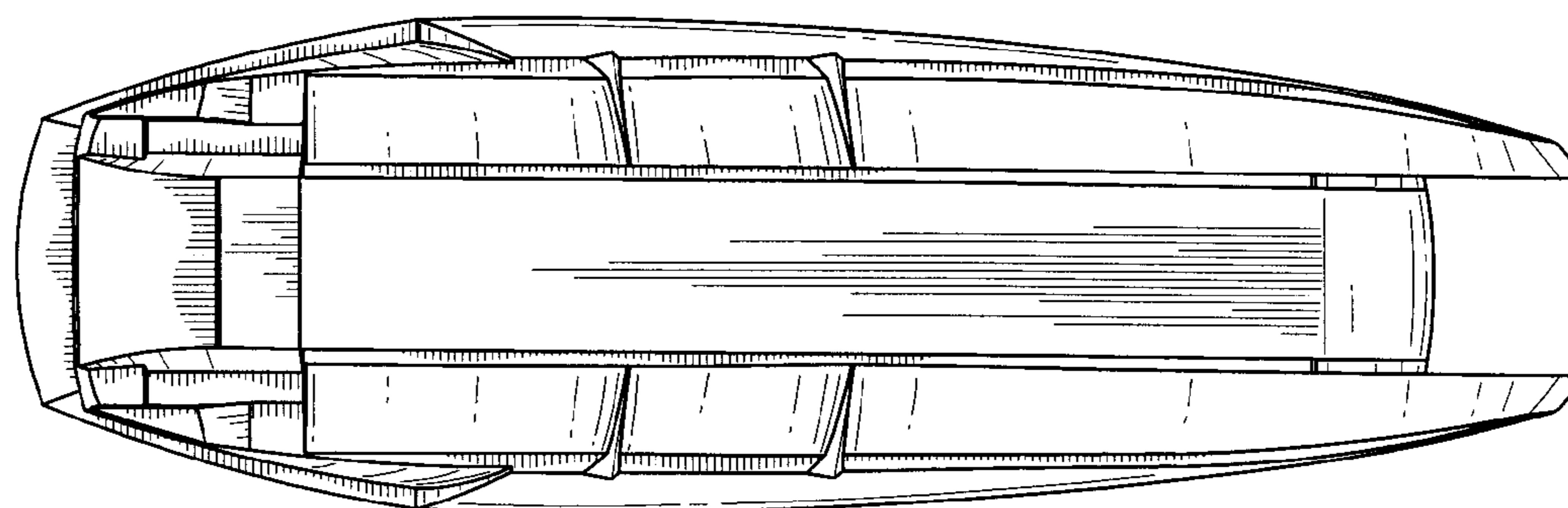

FIG. 5

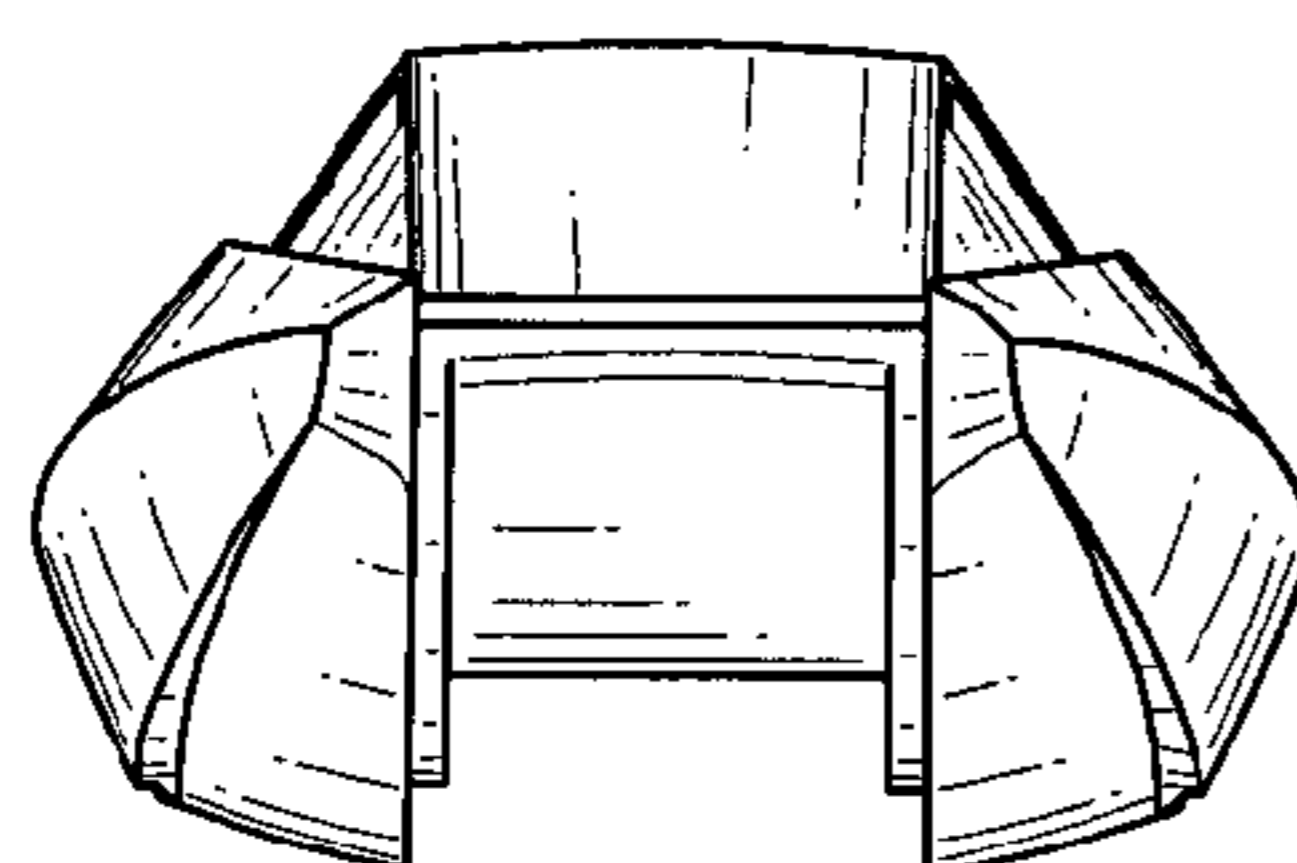

FIG. 6

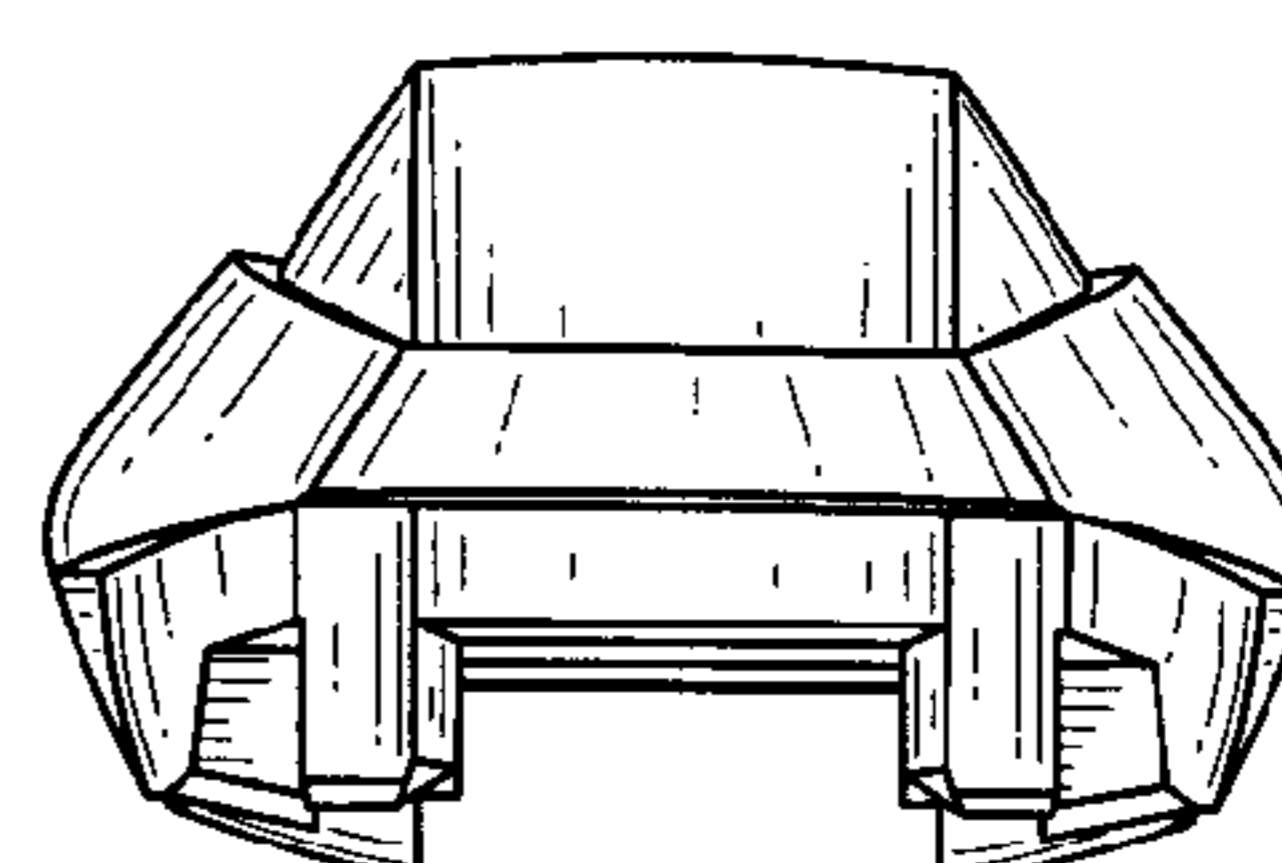

FIG. 7