



US00D572968S

(12) **United States Design Patent**  
**Doo**

(10) **Patent No.:** **US D572,968 S**  
(45) **Date of Patent:** **\*\* Jul. 15, 2008**

(54) **SANDWICH GRILL**

(75) Inventor: **Danny Doo**, Kowloon (CN)

(73) Assignee: **Milsource Ltd.**, Kowloon, Hong Kong (CN)

(\*\*) Term: **14 Years**

(21) Appl. No.: **29/293,474**

(22) Filed: **Nov. 27, 2007**

(51) **LOC (8) Cl.** ..... **07-02**

(52) **U.S. Cl.** ..... **D7/352**

(58) **Field of Classification Search** ..... D7/323,  
D7/328-332, 334-339, 352-363; 99/219,  
99/331, 339-341, 349, 357, 369, 372-375,  
99/385, 386, 446, 466, 601, 618, 620; 219/386,  
219/524, 525, 620-622, 732-734; 220/23.8  
See application file for complete search history.

(56) **References Cited**

**U.S. PATENT DOCUMENTS**

D436,794 S *	1/2001	McClean	.....	D7/352
D452,109 S *	12/2001	Hensel	.....	D7/352
D479,665 S *	9/2003	Barker	.....	D7/352
D509,703 S *	9/2005	Barker	.....	D7/352
D527,941 S *	9/2006	Serra	.....	D7/352
D528,350 S *	9/2006	McHutchison	.....	D7/352
D532,646 S *	11/2006	Moore	.....	D7/352
D539,074 S *	3/2007	Lubowicki	.....	D7/352
D541,581 S *	5/2007	Moore	.....	D7/352

D541,582 S *	5/2007	Chuang et al.	.....	D7/352
D546,619 S *	7/2007	McHutchison	.....	D7/352
D550,025 S *	9/2007	Chao	.....	D7/352
D550,026 S *	9/2007	Chao	.....	D7/352

**FOREIGN PATENT DOCUMENTS**

WO WO 2005002407 A1 \* 1/2005

**OTHER PUBLICATIONS**

NapaStyle, Late Sunner 2006, Item "B" Napa Style Panini Grill, p. 41.\*

Kitchen Kapers, Holiday 2006, Cuisinart 4 in 1 Griddler, p. 20.\*

\* cited by examiner

*Primary Examiner*—Caron D. Veynar

*Assistant Examiner*—Ricky Pham

(74) *Attorney, Agent, or Firm*—Alix, Yale & Ristas, LLP

(57) **CLAIM**

The ornamental design for a sandwich grill, as shown.

**DESCRIPTION**

FIG. 1 is a front view of a sandwich grill showing my new design;

FIG. 2 is a top plan view thereof;

FIG. 3 is a left side view thereof;

FIG. 4 is a right side view thereof;

FIG. 5 is a rear view thereof; and,

FIG. 6 is a bottom plan view thereof.

**1 Claim, 3 Drawing Sheets**

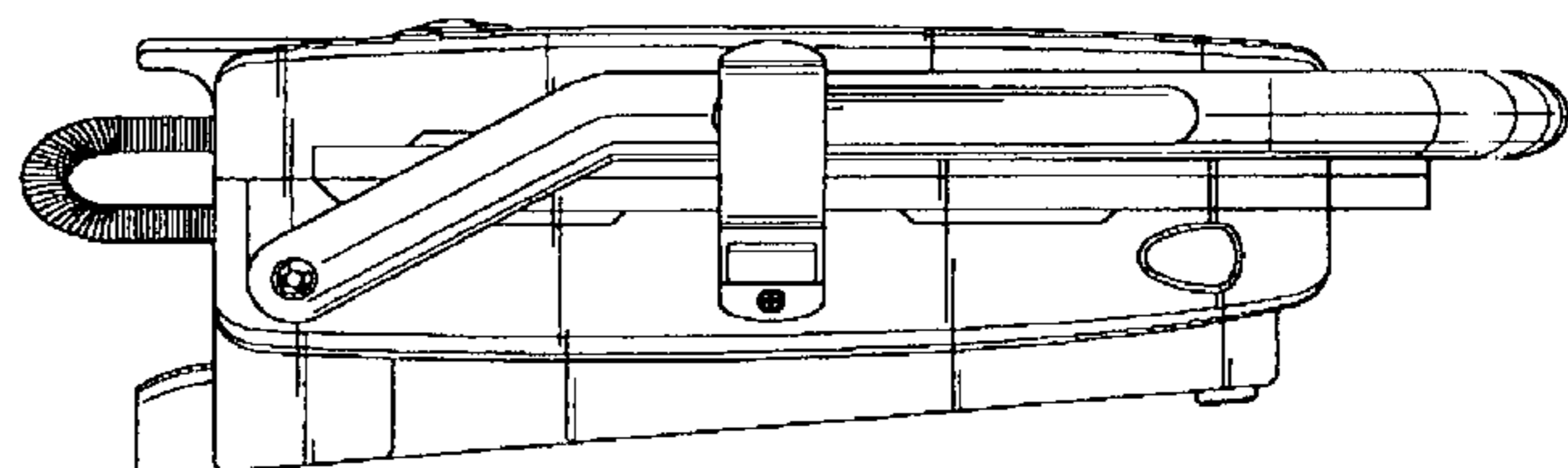
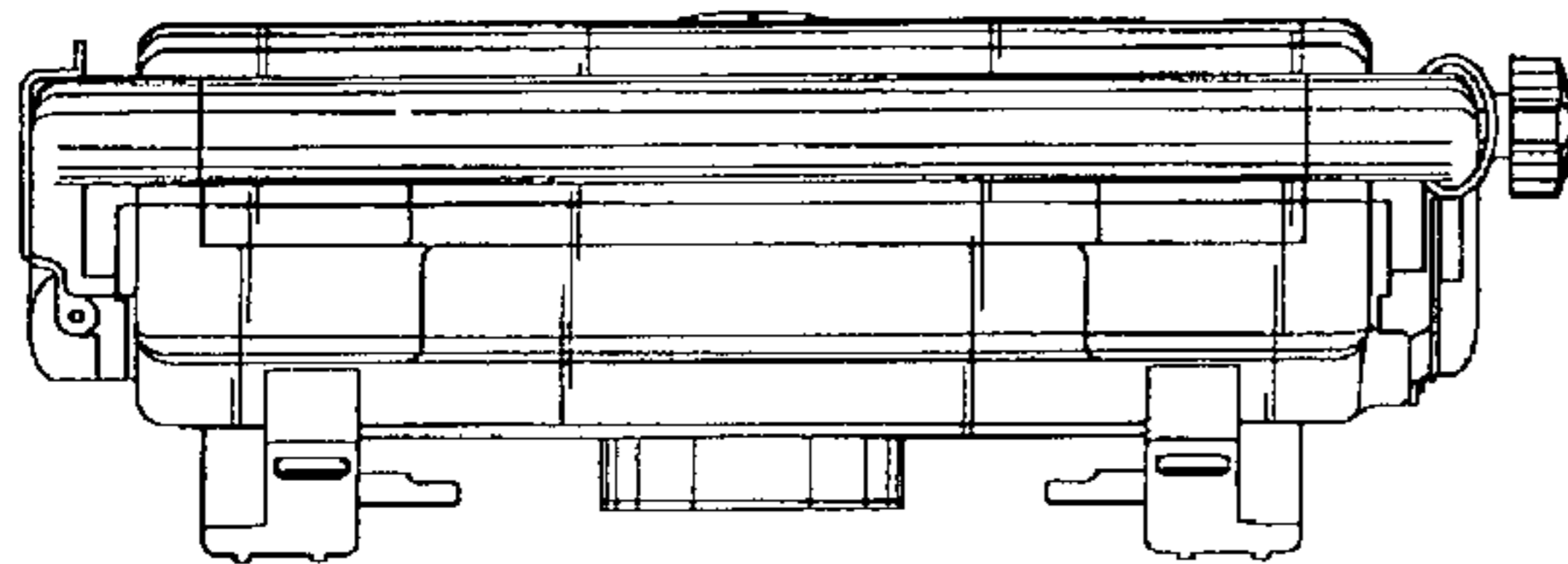

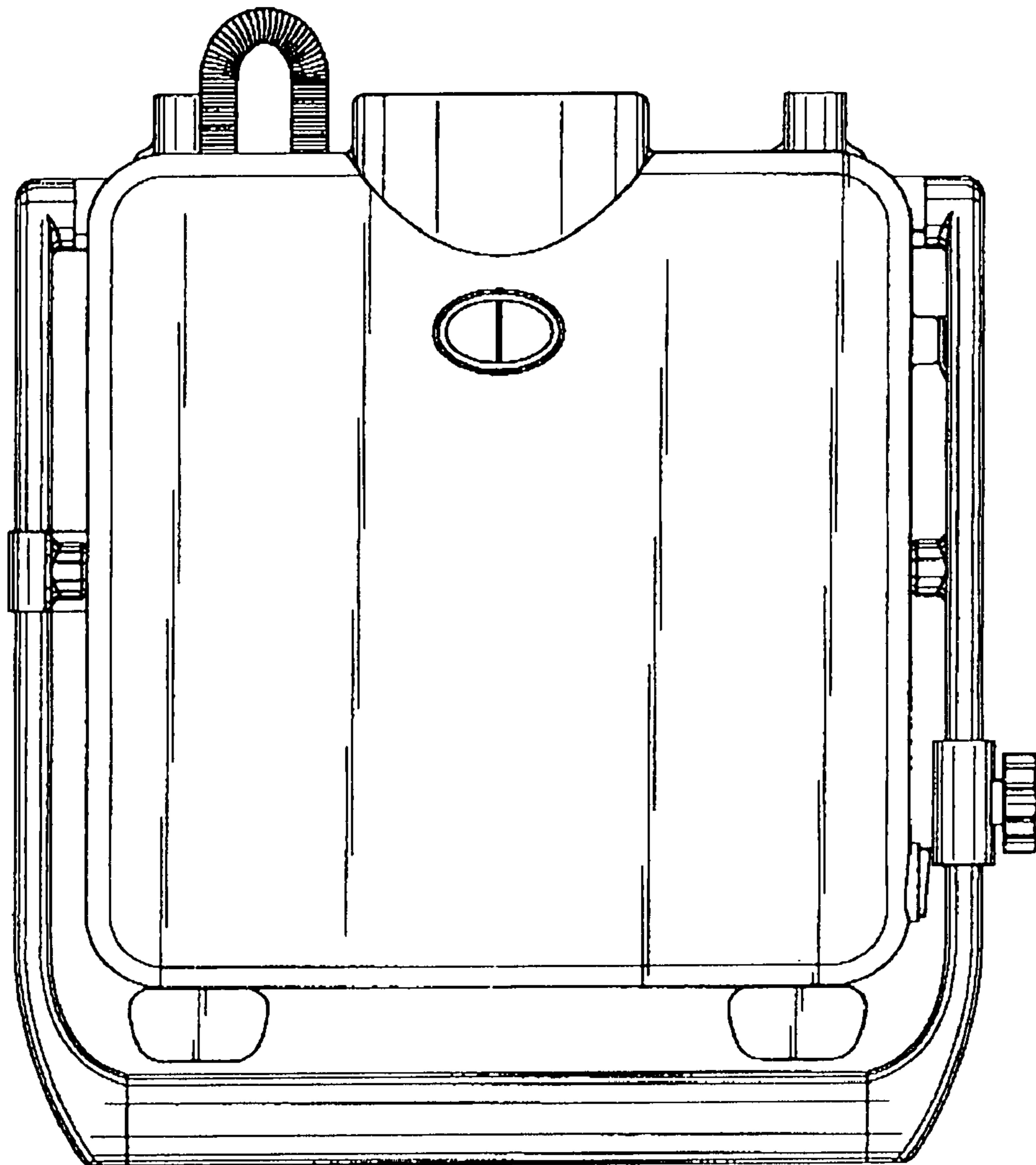

FIG. 2

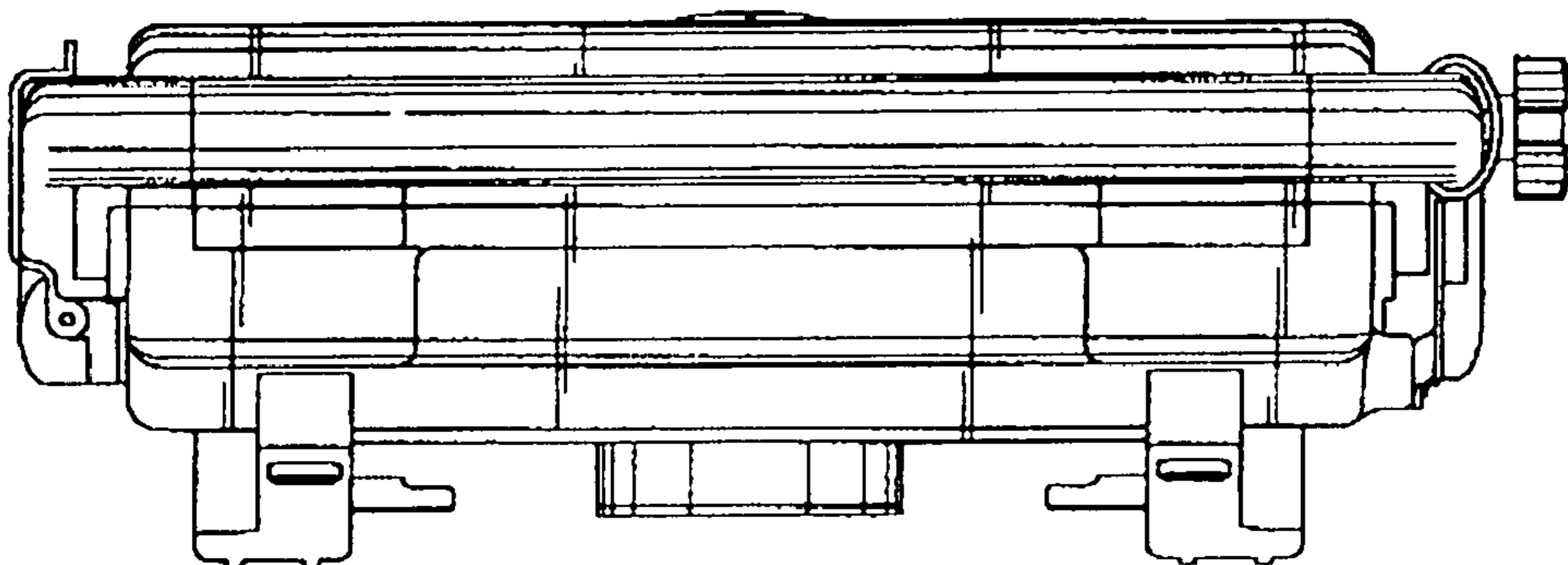

FIG. 1

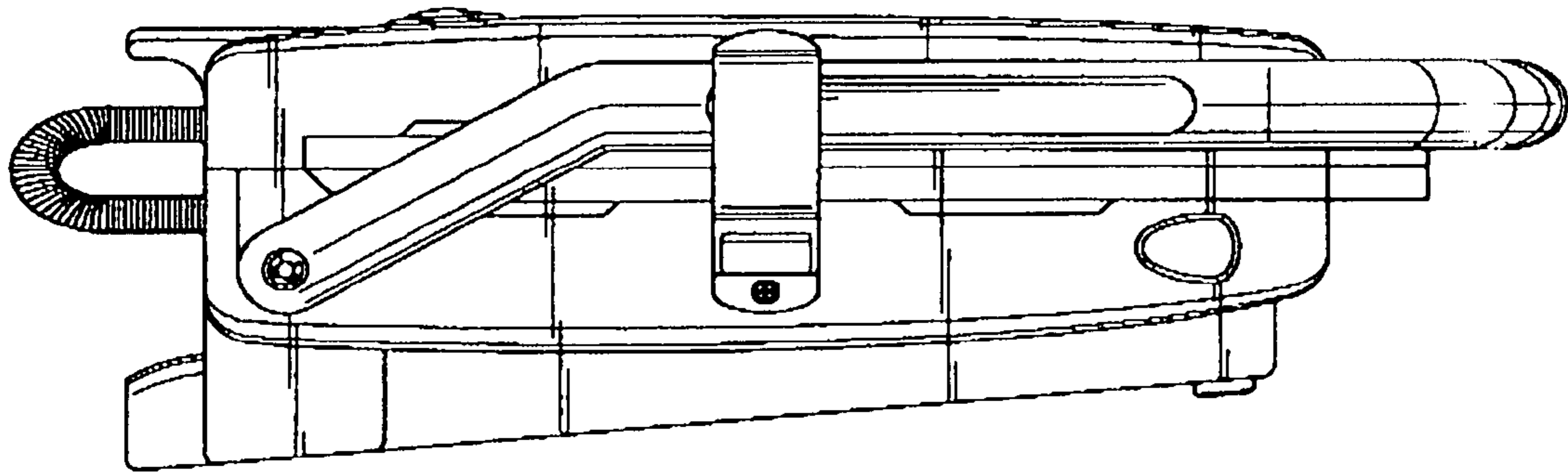

FIG. 3

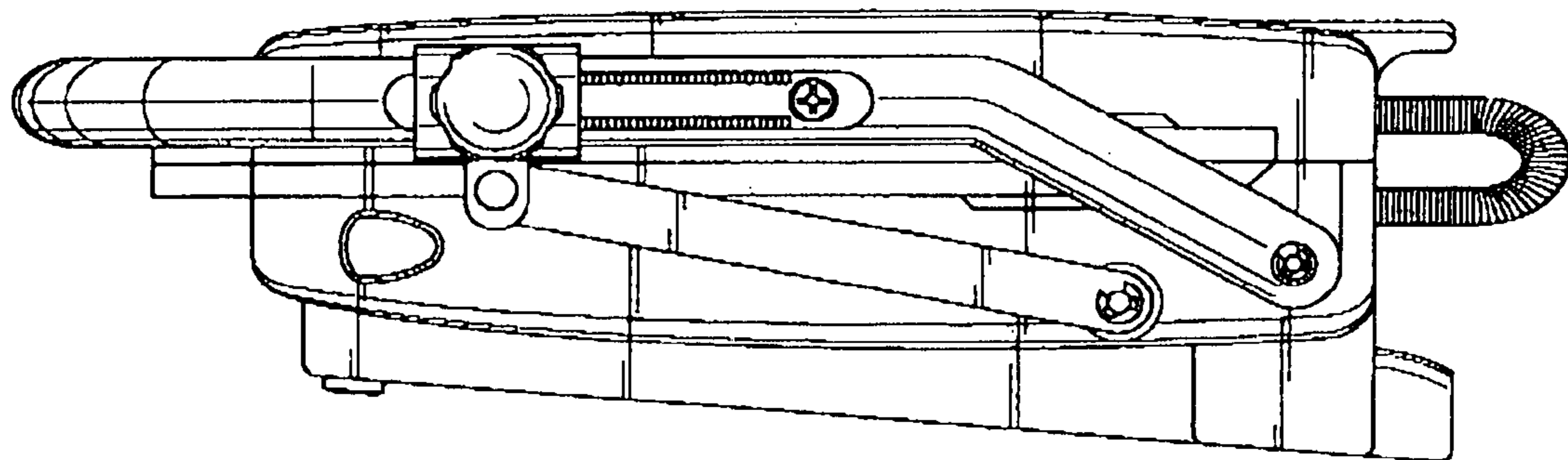

FIG. 4

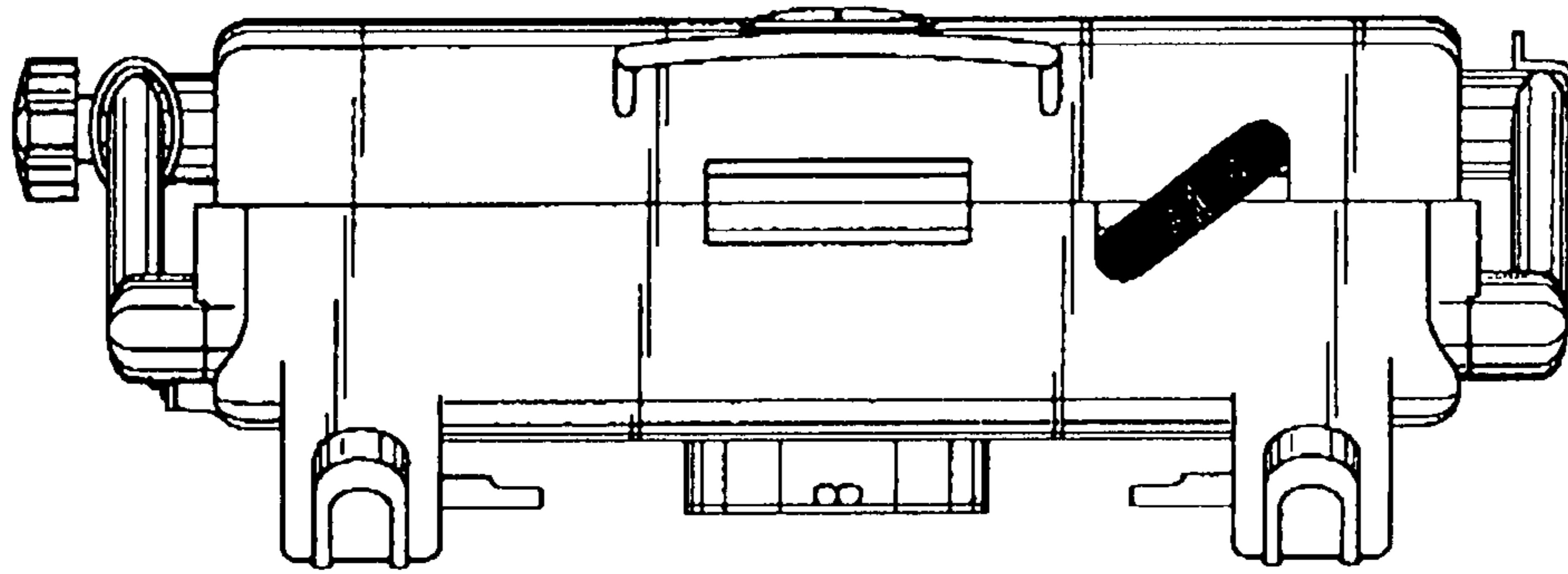

FIG. 5

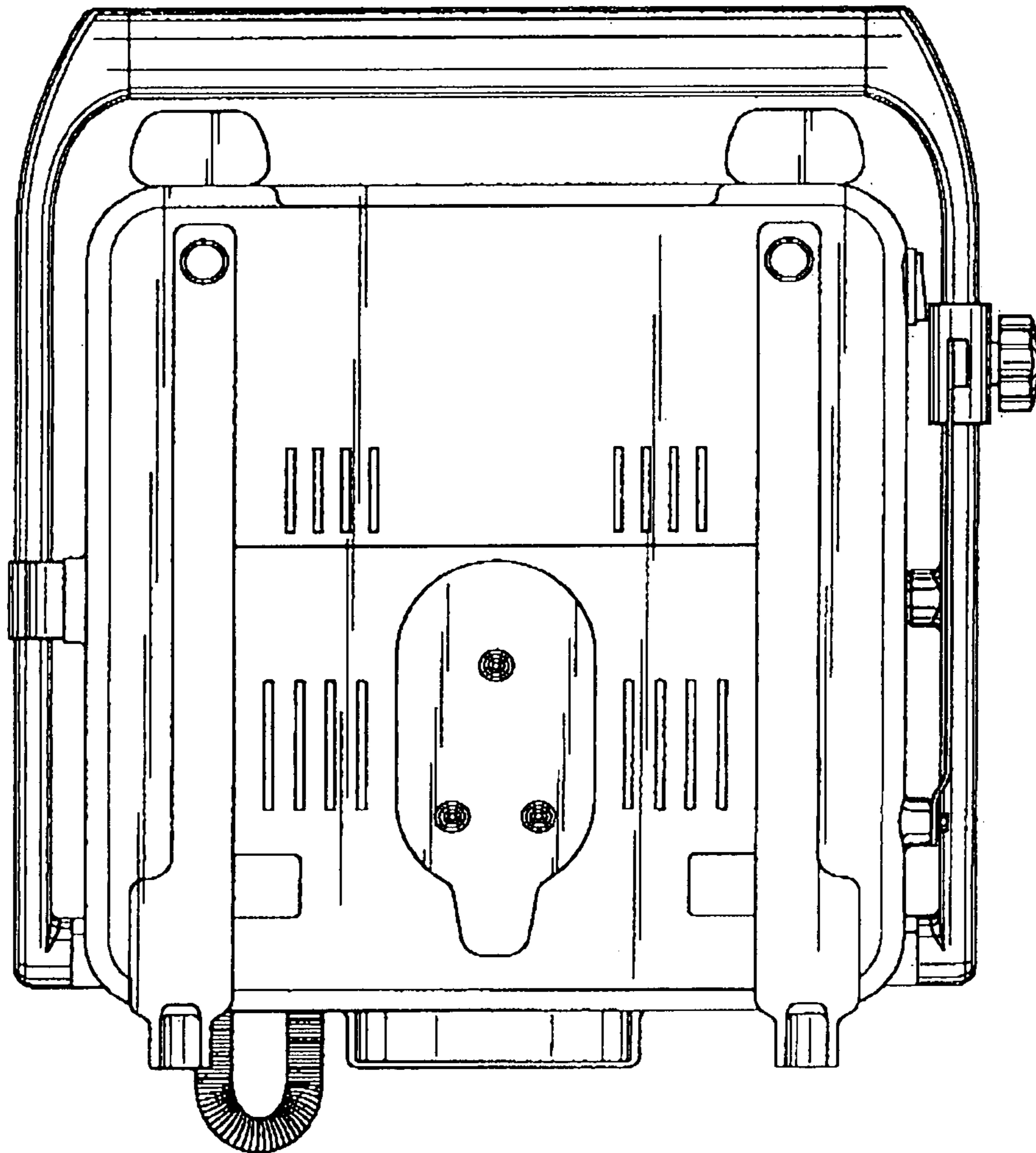

FIG. 6