



US00D572834S

(12) **United States Design Patent**  
**Wickland**

(10) **Patent No.:** **US D572,834 S**  
(45) **Date of Patent:** **\*\* Jul. 8, 2008**

(54) **WINDOW COMPONENT EXTRUSION 9552 AND 9553**

(75) Inventor: **Timothy Todd Wickland**, Auburn, WA (US)

(73) Assignee: **Mikron Industries, Inc.**, Kent, WA (US)

(\*\*) Term: **14 Years**

(21) Appl. No.: **29/288,405**

(22) Filed: **Jun. 8, 2007**

(51) **LOC (8) Cl.** ..... **25-01**

(52) **U.S. Cl.** ..... **D25/124**

(58) **Field of Classification Search** ..... D25/121, D25/122, 124, 125; 52/204.59, 204.1, 204.2, 52/204.5, 204.51, 656.5, 656.6, 213, 215, 52/208, 293.3, 204.97, 204.595, 204.71, 52/730.3, 656.2; 49/209, 501, 504, DIG. 2  
See application file for complete search history.

(56) **References Cited**

**U.S. PATENT DOCUMENTS**

4,974,364	A *	12/1990	Durham, Jr.	49/400
5,687,518	A *	11/1997	Endo et al.	52/204.1
5,687,519	A *	11/1997	Bruchu	52/213
6,055,782	A *	5/2000	Morton et al.	52/204.1
6,182,405	B1 *	2/2001	Lindahl	52/204.1
D443,702	S *	6/2001	Ballard et al.	D25/124
6,327,826	B1 *	12/2001	Mann	52/204.1
6,330,769	B1 *	12/2001	Manzella et al.	52/204.62
6,334,283	B1 *	1/2002	Edger	52/204.1
D453,381	S *	2/2002	Ballard et al.	D25/124
D461,255	S *	8/2002	Ballard et al.	D25/124
D465,583	S *	11/2002	Ballard et al.	D25/124
D466,621	S *	12/2002	Ballard et al.	D25/124

D466,623	S *	12/2002	Ballard et al.	D25/124
D467,011	S *	12/2002	Ballard et al.	D25/124
D467,355	S *	12/2002	Ballard et al.	D25/124
6,490,831	B1 *	12/2002	Candusso	52/204.1
D505,503	S	5/2005	Wickland	
7,246,466	B2 *	7/2007	Turner	49/504
2004/0226232	A1 *	11/2004	Engebretson	52/204.1

**OTHER PUBLICATIONS**

Mikron Part No. 7778 conceived of by Michael Fannan and first sold prior to 2004.

Mikron Part No. 7947 conceived of by Douglas Cole on Mar. 2, 1999 and first sold on Dec. 23, 1999.

\* cited by examiner

*Primary Examiner*—Doris Clark

(74) *Attorney, Agent, or Firm*—Black Lowe & Graham PLLC

(57) **CLAIM**

The ornamental design for a window component extrusion 9552 and 9553, as shown and described.

**DESCRIPTION**

FIG. 1 is a top left isometric perspective view of the window component extrusion which is broken in the center indicating indefinite length.

FIG. 2 is a bottom right isometric perspective view of the window component extrusion shown in FIG. 1.

FIG. 3 is a top left isometric perspective view of a second embodiment of the window component extrusion which is broken in the center indicating indefinite length; and,

FIG. 4 is a bottom right isometric perspective view of the window component extrusion shown in FIG. 3.

**1 Claim, 4 Drawing Sheets**

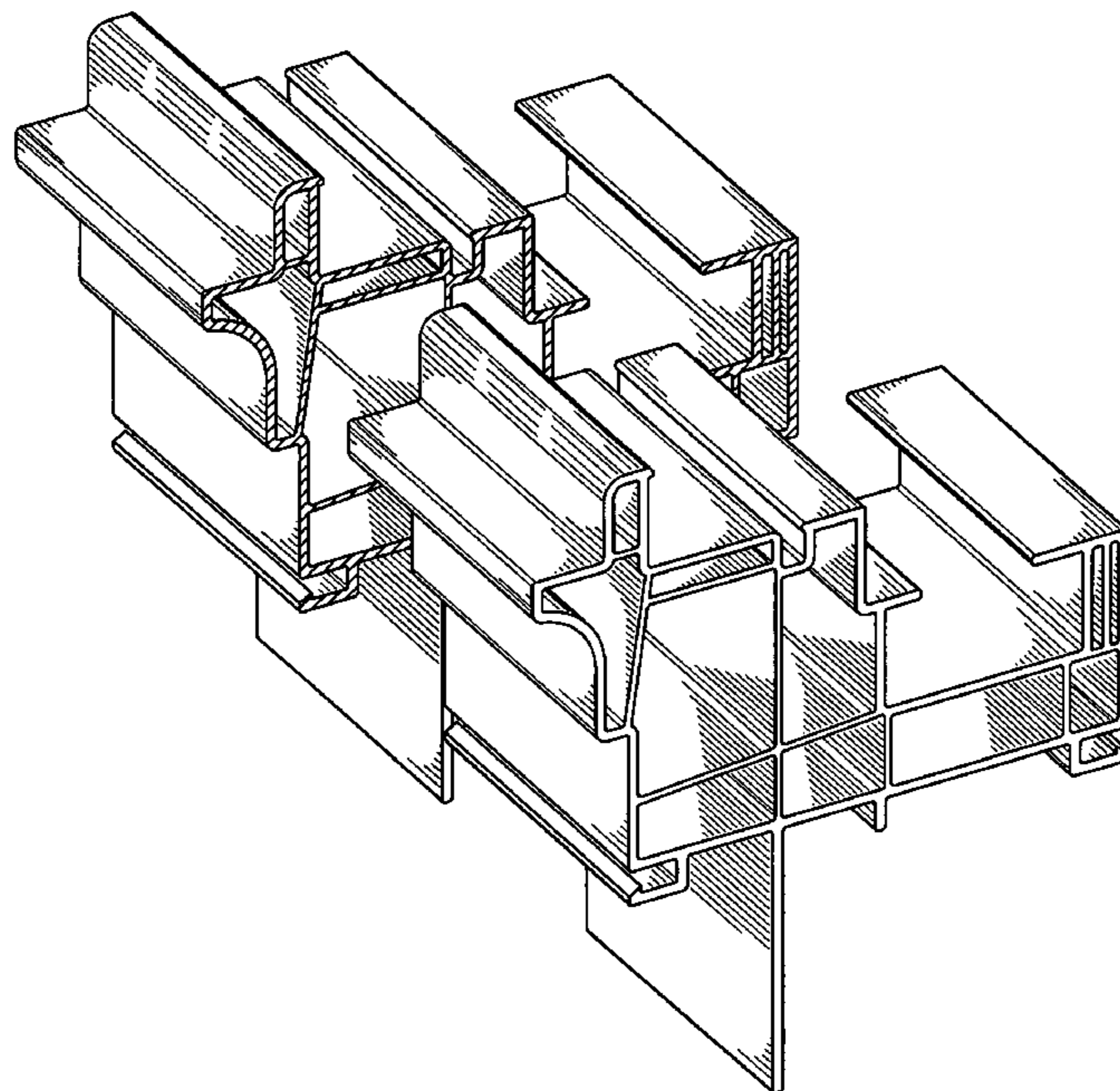

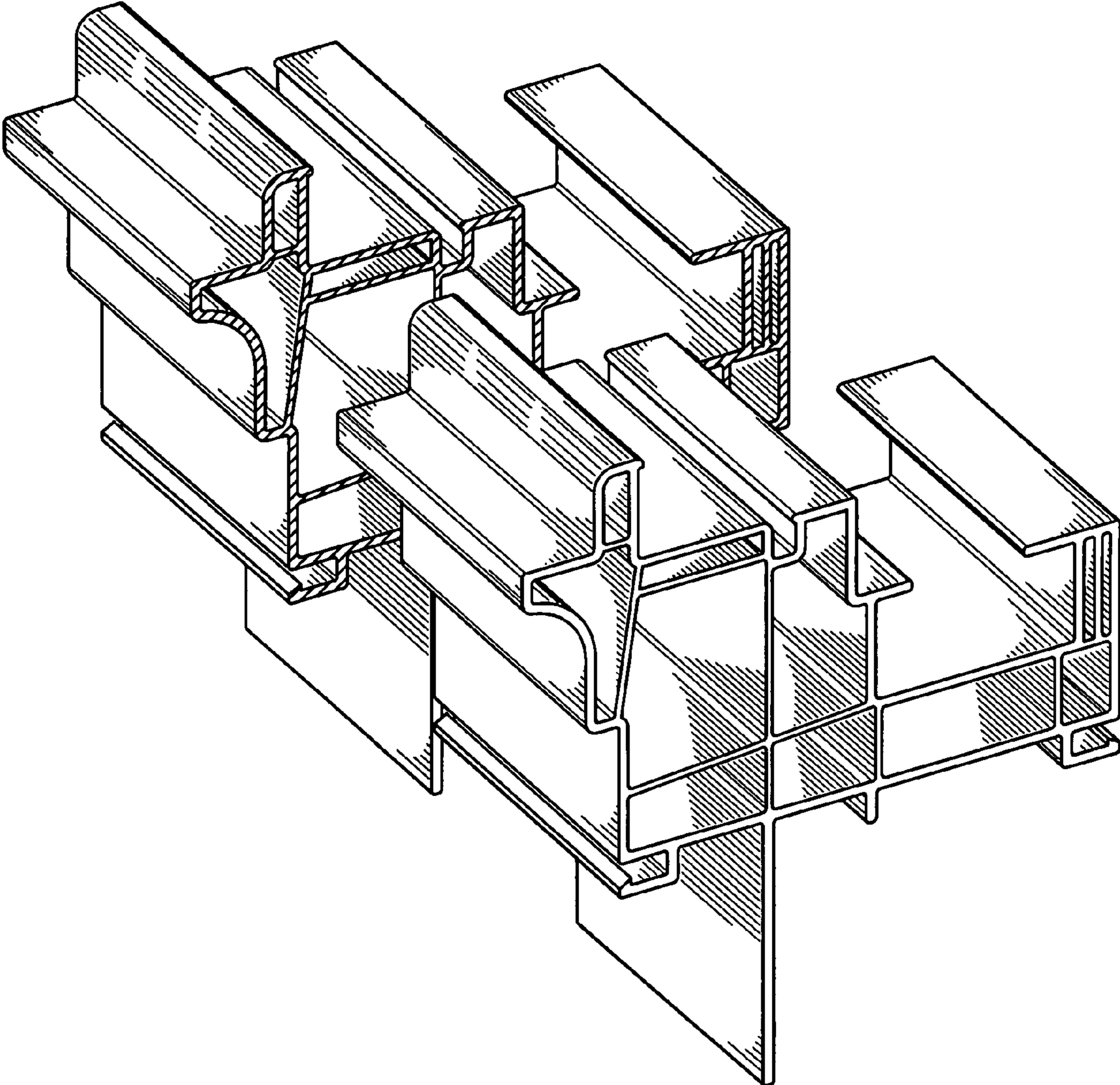

FIG.1

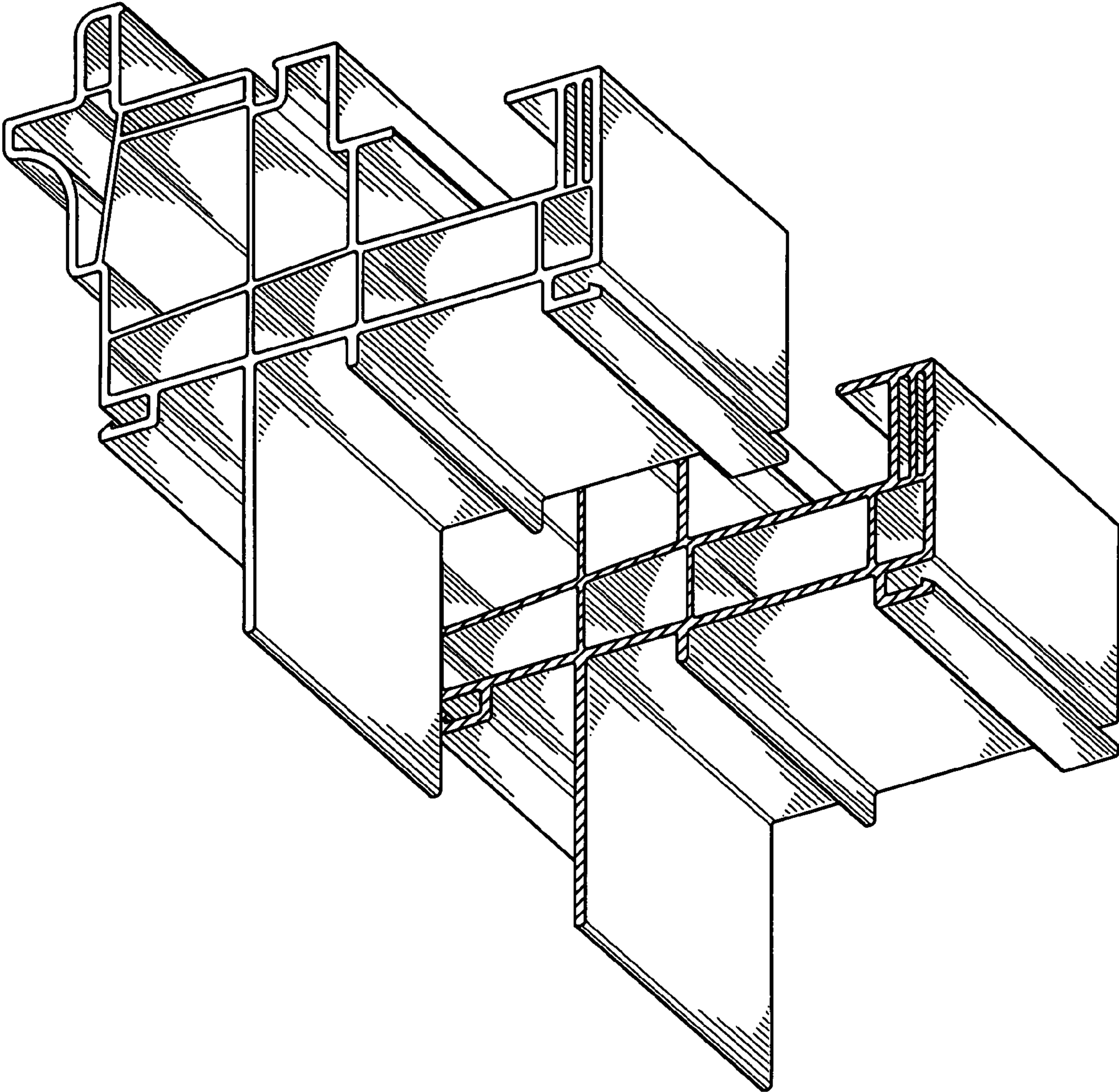

FIG.2

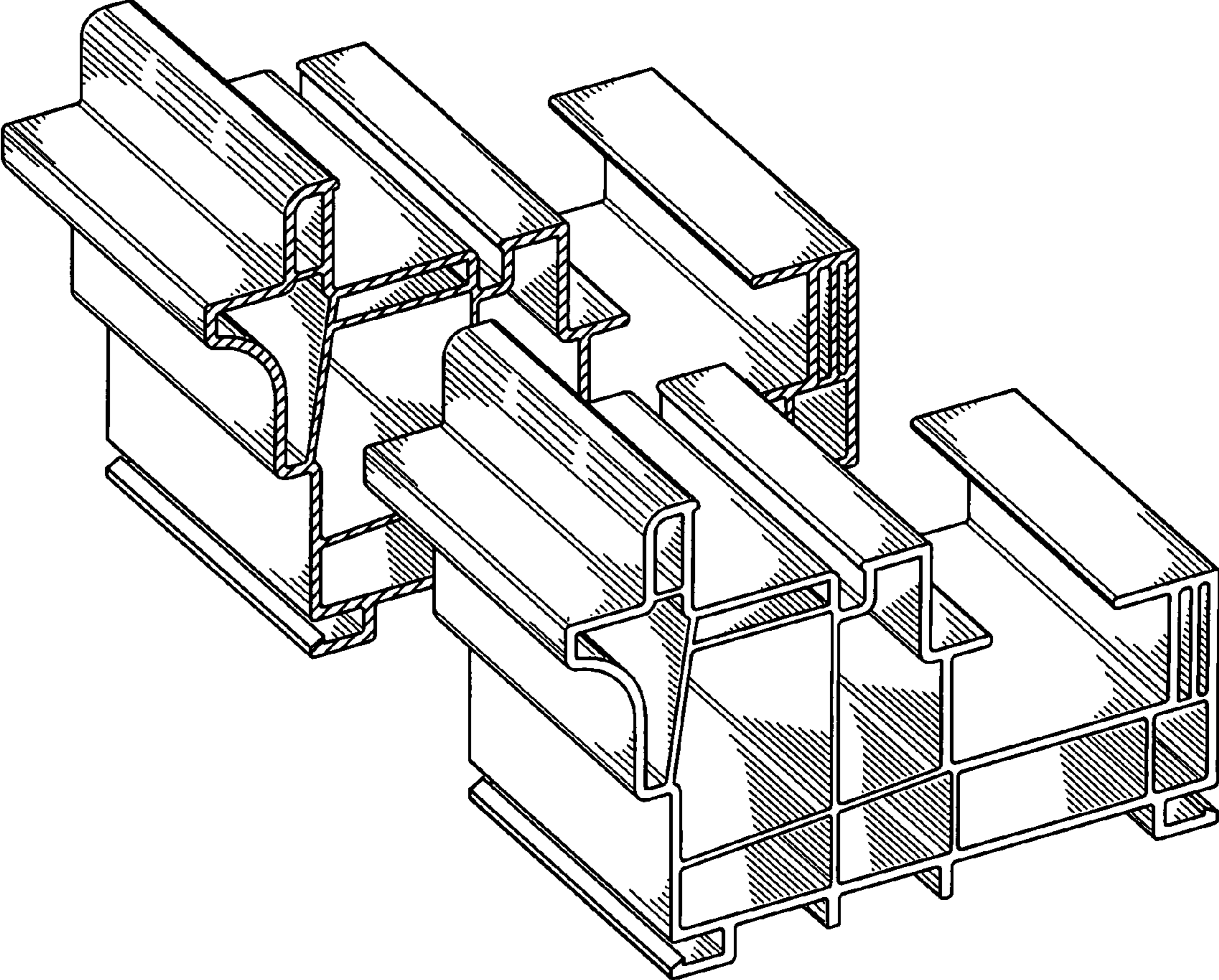

FIG. 3

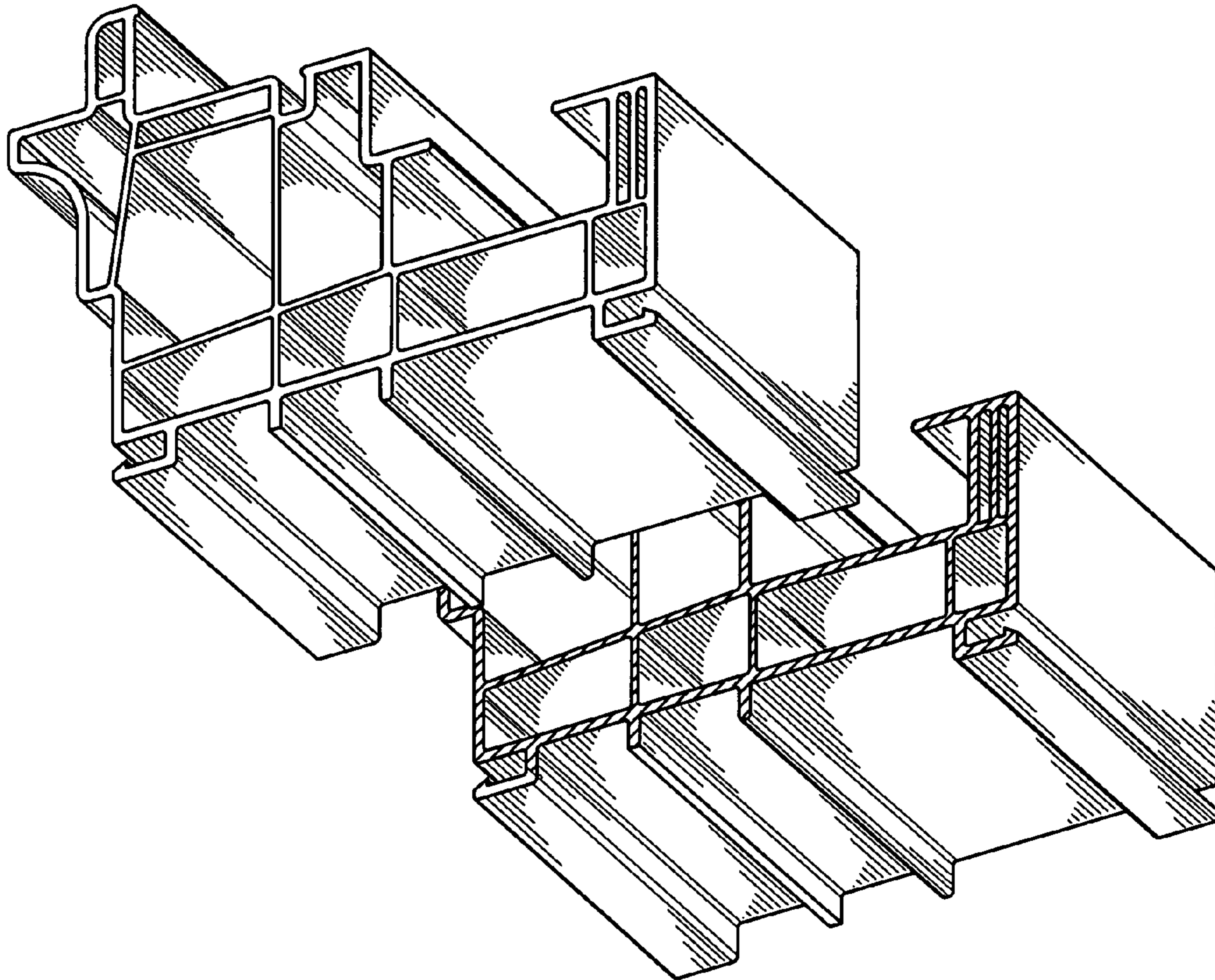

FIG.4