



US00D572645S

(12) **United States Design Patent**
McChesney et al.

(10) **Patent No.:** **US D572,645 S**
(45) **Date of Patent:** **** Jul. 8, 2008**

(54) **AUTOMOTIVE FRONT END**

(75) Inventors: **Mark McChesney**, Saline, MI (US);
James Kuo, Farmington Hills, MI (US);
Patrick Schiavone, Birmingham, MI
(US); **Chelsia Lau**, Ann Arbor, MI (US)

(73) Assignee: **Ford Global Technologies, LLC**,
Dearborn, MI (US)

(**) Term: **14 Years**

(21) Appl. No.: **29/225,432**

(22) Filed: **Mar. 15, 2005**

(51) **LOC (8) Cl.** **12-16**

(52) **U.S. Cl.** **D12/196**

(58) **Field of Classification Search** D12/90-92,
D12/173, 196, 86; 180/69.21, 69.2, 69.22;
296/24.4

See application file for complete search history.

(56) **References Cited**

U.S. PATENT DOCUMENTS

D484,835 S *	1/2004	Chiang	D12/173
D495,633 S *	9/2004	Chiang	D12/173
D497,854 S *	11/2004	Chiang	D12/173
D502,128 S *	2/2005	Chiang	D12/173
D506,713 S *	6/2005	Chiang	D12/173
D514,483 S *	2/2006	Chiang	D12/173

OTHER PUBLICATIONS

<http://www.fordvehicles.com/suvs/explorersporttrac/>, Ford
Vehicles: 2005 Ford Explorer Sport Trac—See pricing details, SUV
options, packages and more, 16 pages.

* cited by examiner

Primary Examiner—Melody N Brown
(74) *Attorney, Agent, or Firm*—Frank A. MacKenzie; Brooks
Kushman P.C.

(57) **CLAIM**

The ornamental design for an automotive front end, as shown
and described.

DESCRIPTION

FIG. 1 is a front end perspective view of an automotive front
end in accordance with the present invention;

FIG. 2 is a front end/right side perspective view of the auto-
motive front end of FIG. 1, wherein a front end/left side
perspective view is a mirror image thereof;

FIG. 3 is a right side perspective view of the automotive front
end of FIG. 1, wherein a left side perspective view is a mirror
image thereof; and

FIG. 4 is a top/rear perspective view of the automotive front
end of FIG. 1.

FIG. 5 is a front end perspective view of a second embodiment
of automotive design lines in accordance with the present
invention;

FIG. 6 is a front end/right side perspective view of the auto-
motive design lines of FIG. 5, wherein a front end/left side
view is a mirror image thereof;

FIG. 7 is a front end perspective view of a third embodiment
of automotive design lines in accordance with the present
invention; and,

FIG. 8 is a front end/right side perspective view of the auto-
motive design lines of FIG. 7, wherein a front end/left side
view is a mirror image thereof.

The broken lines are for illustrative purposes only and form
no part of the claimed design.

1 Claim, 4 Drawing Sheets

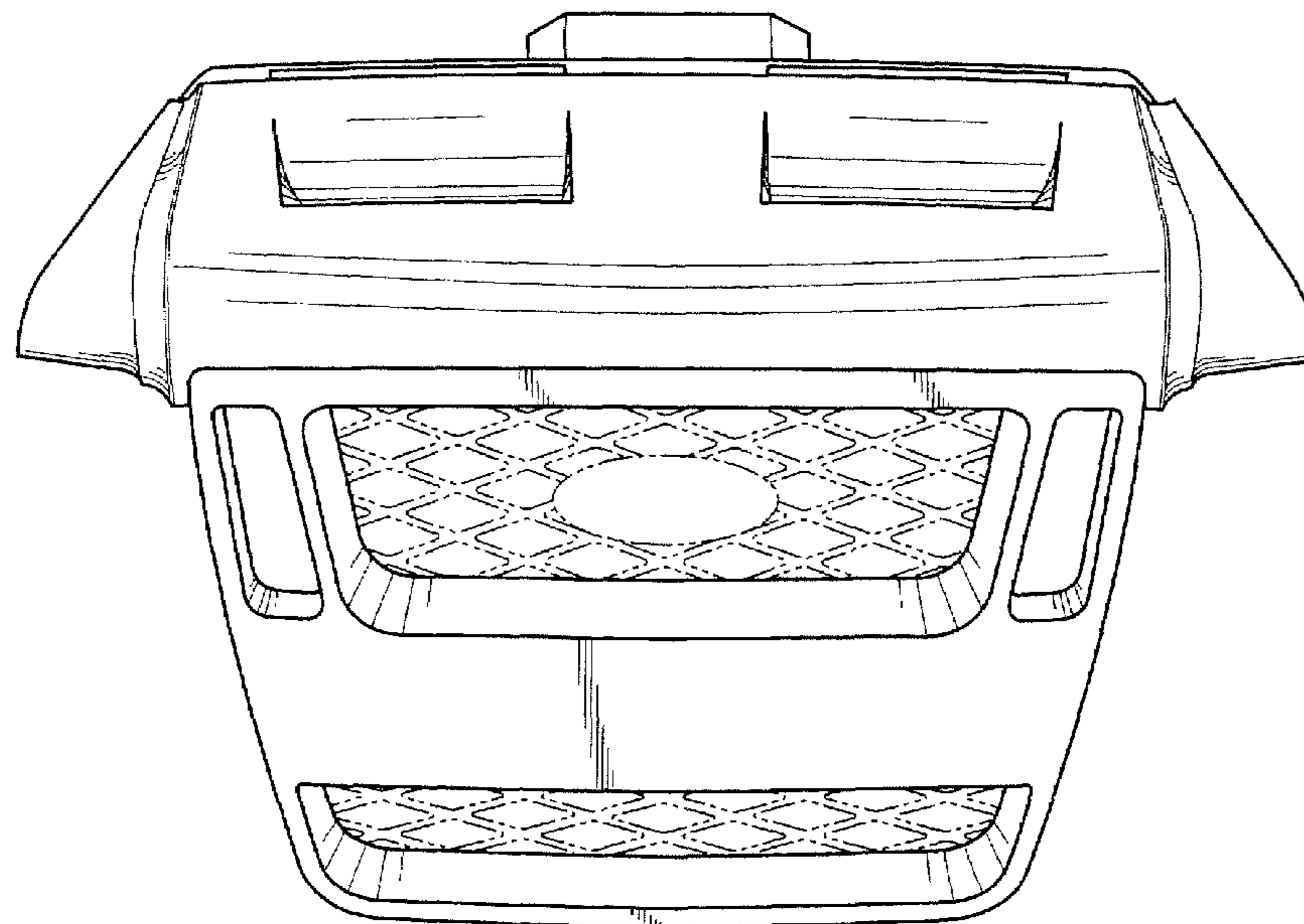

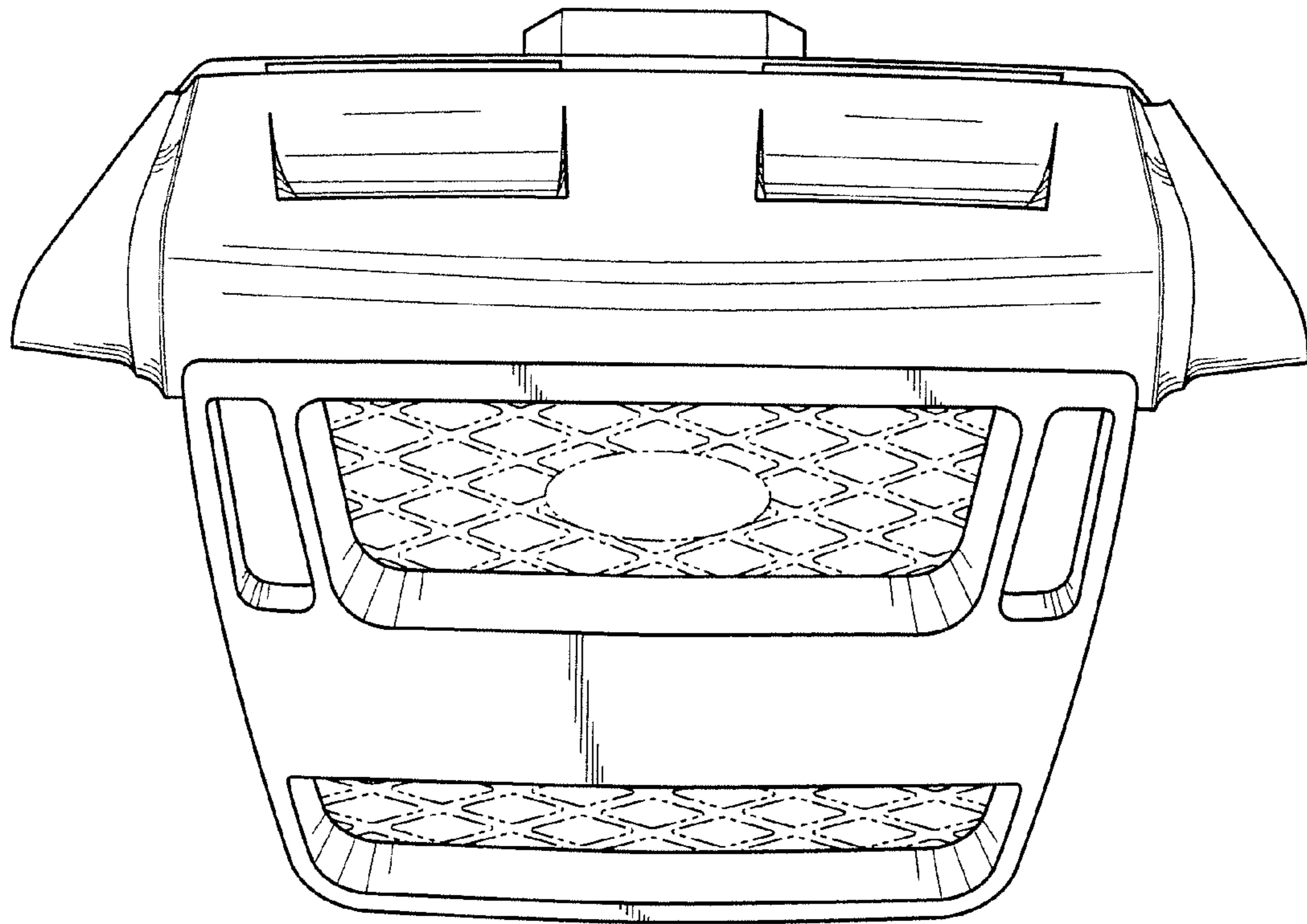

FIG - 1

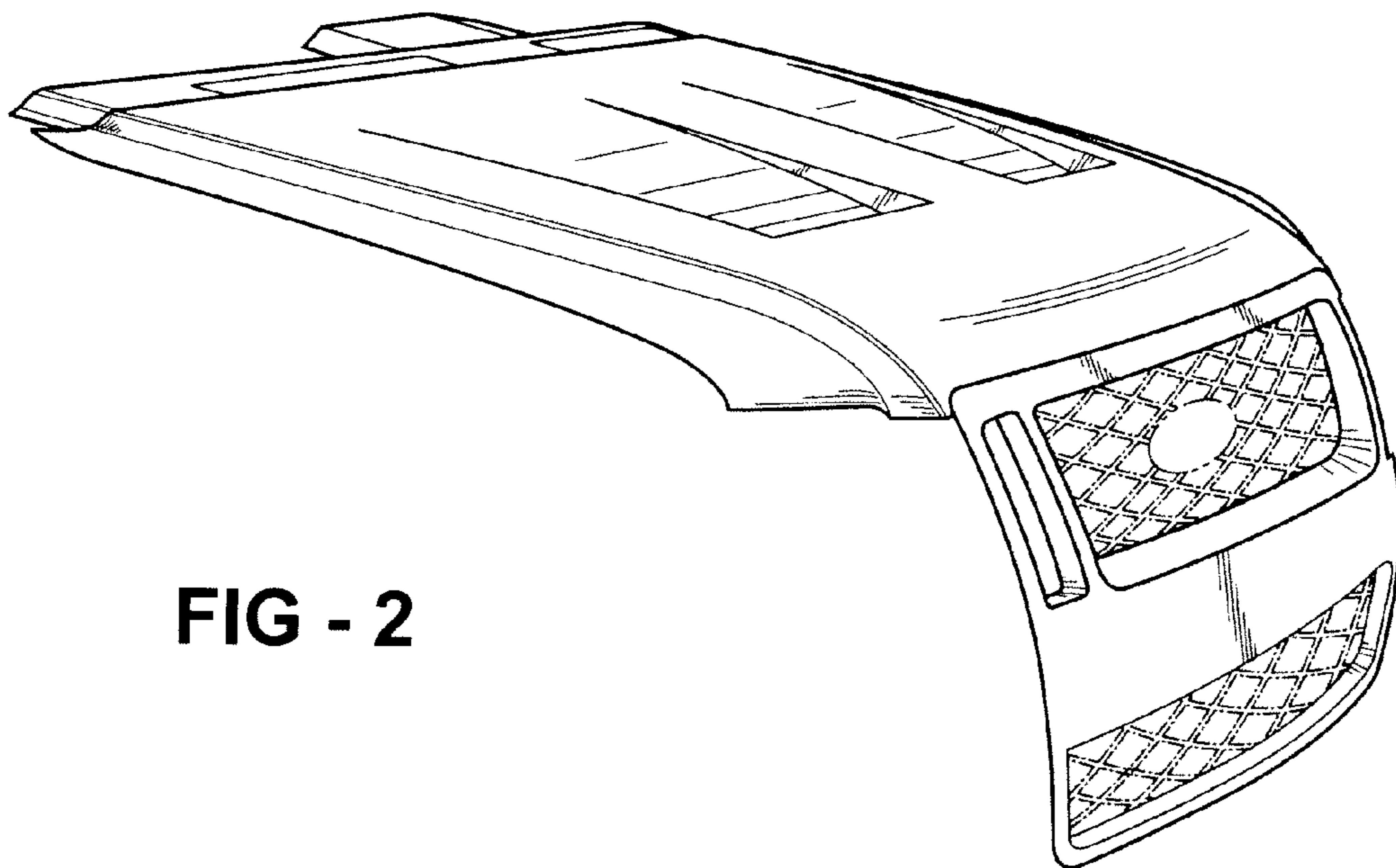

FIG - 2

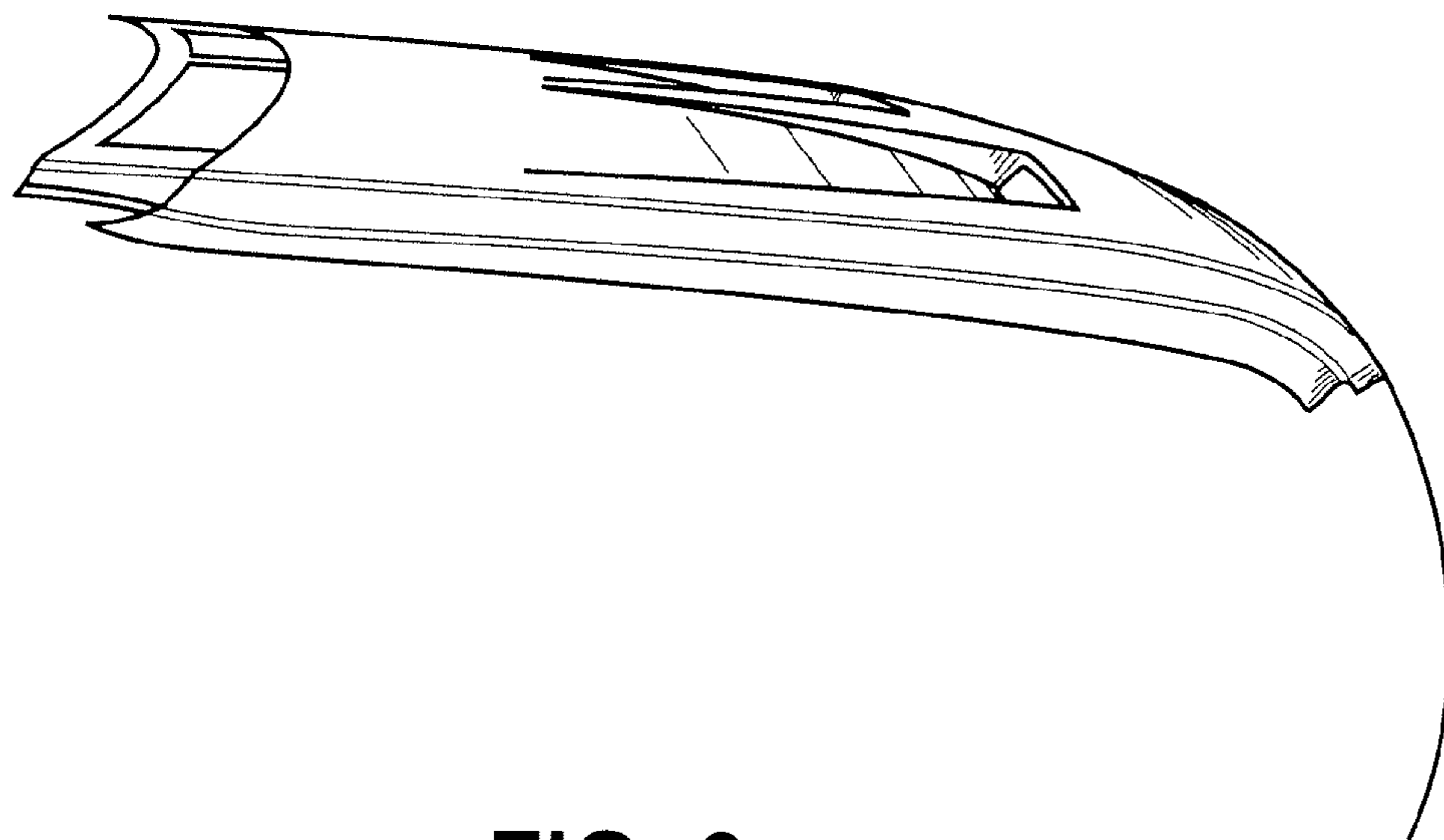

FIG -3

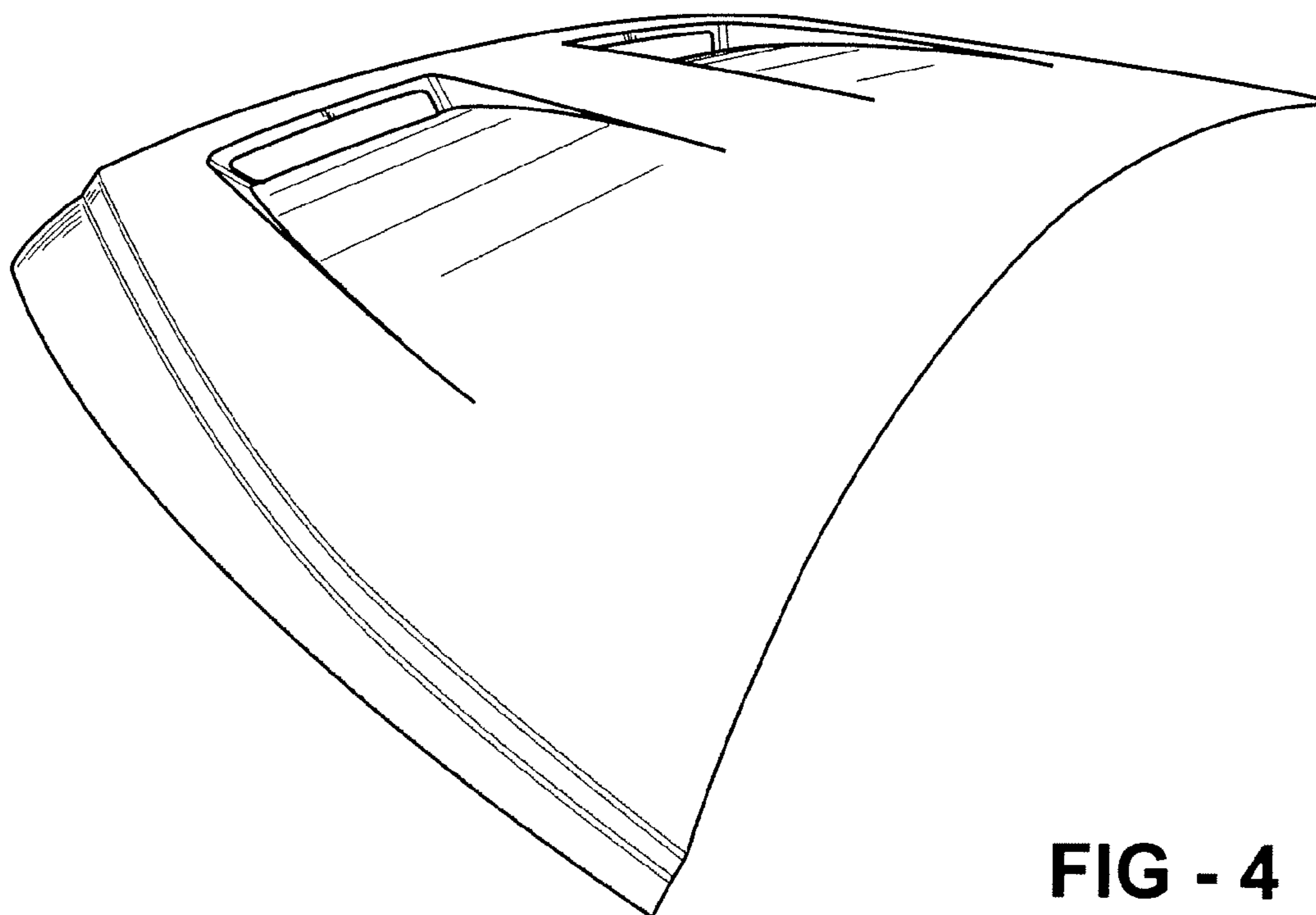

FIG - 4

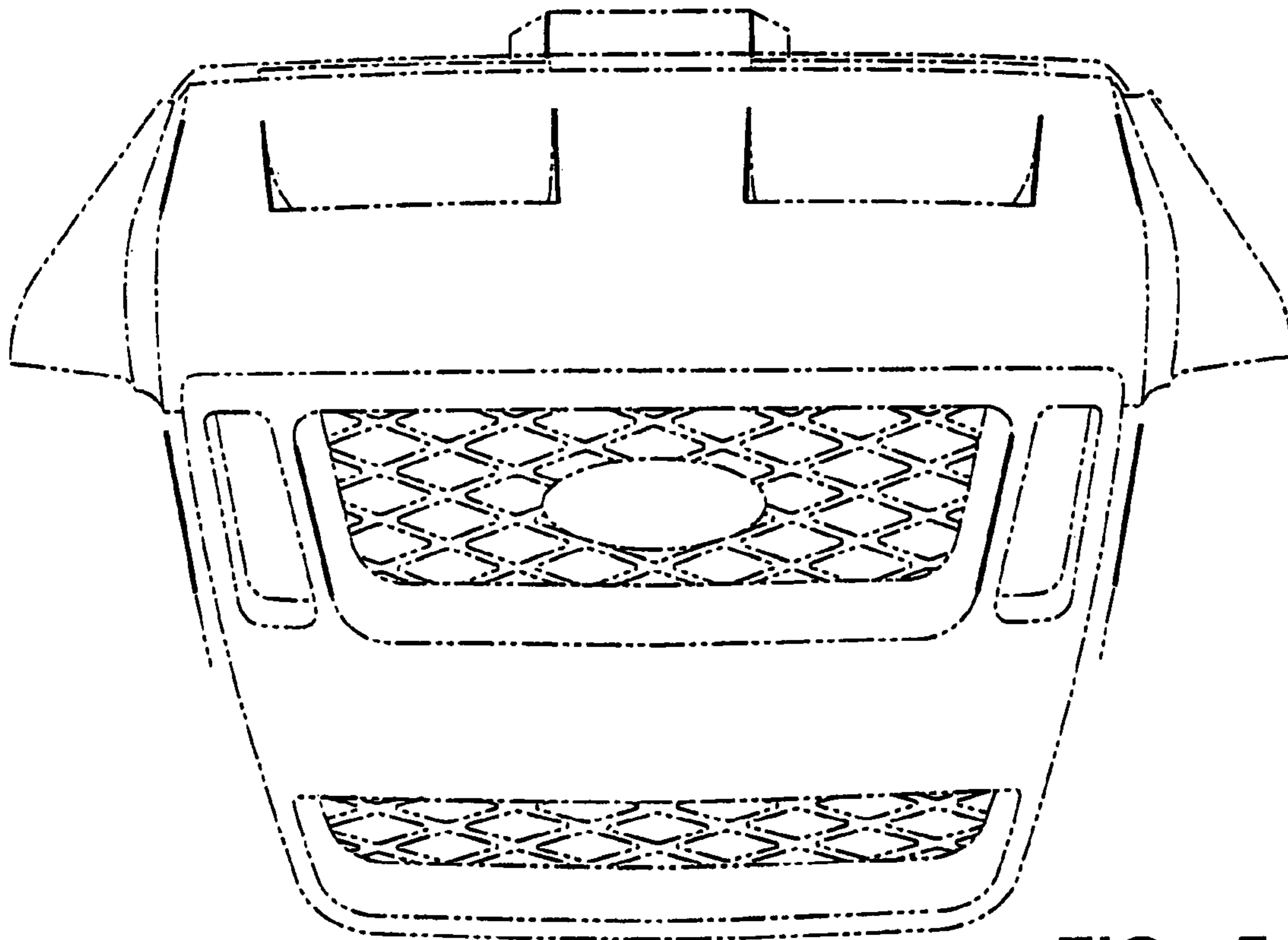

FIG - 5

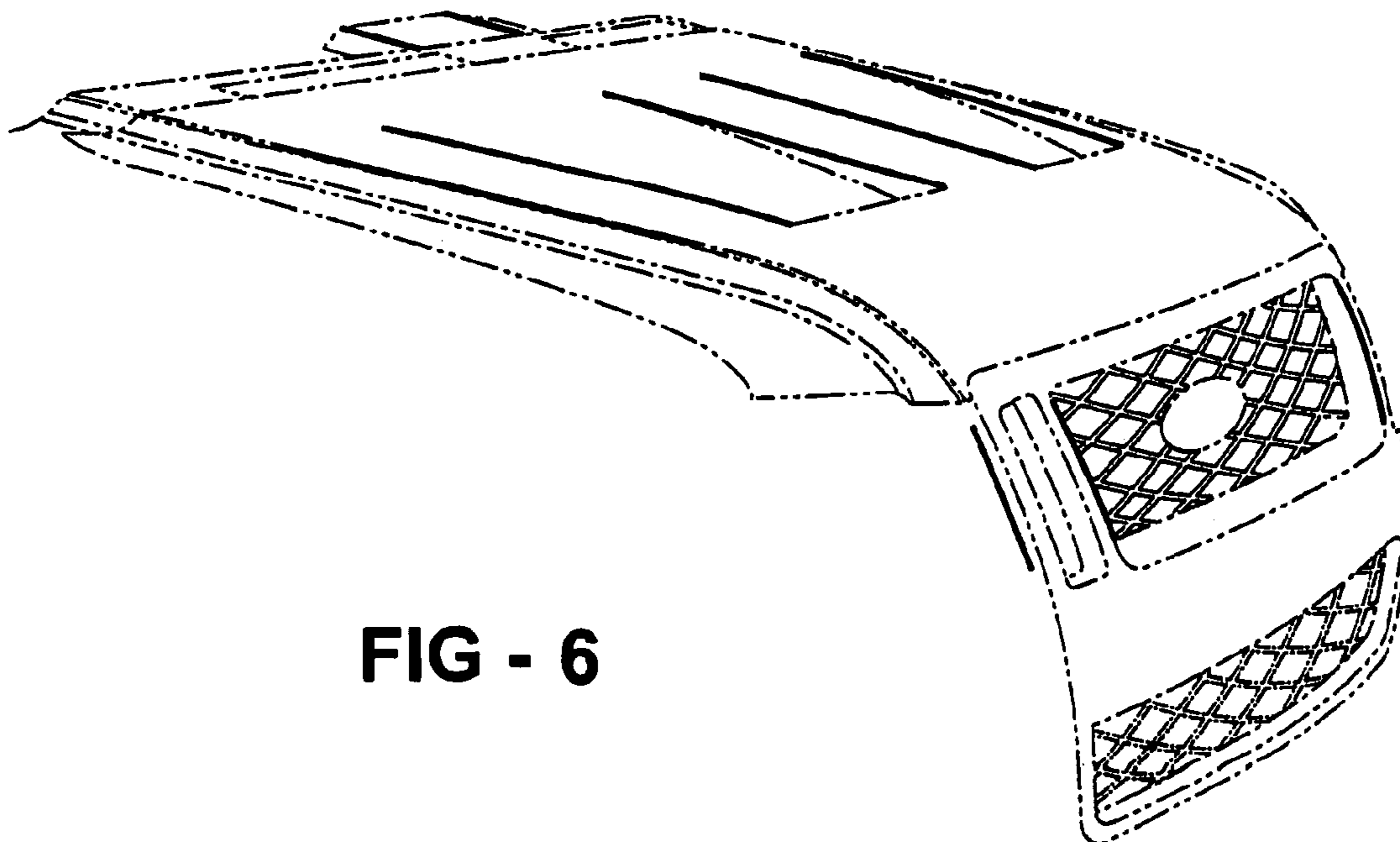

FIG - 6

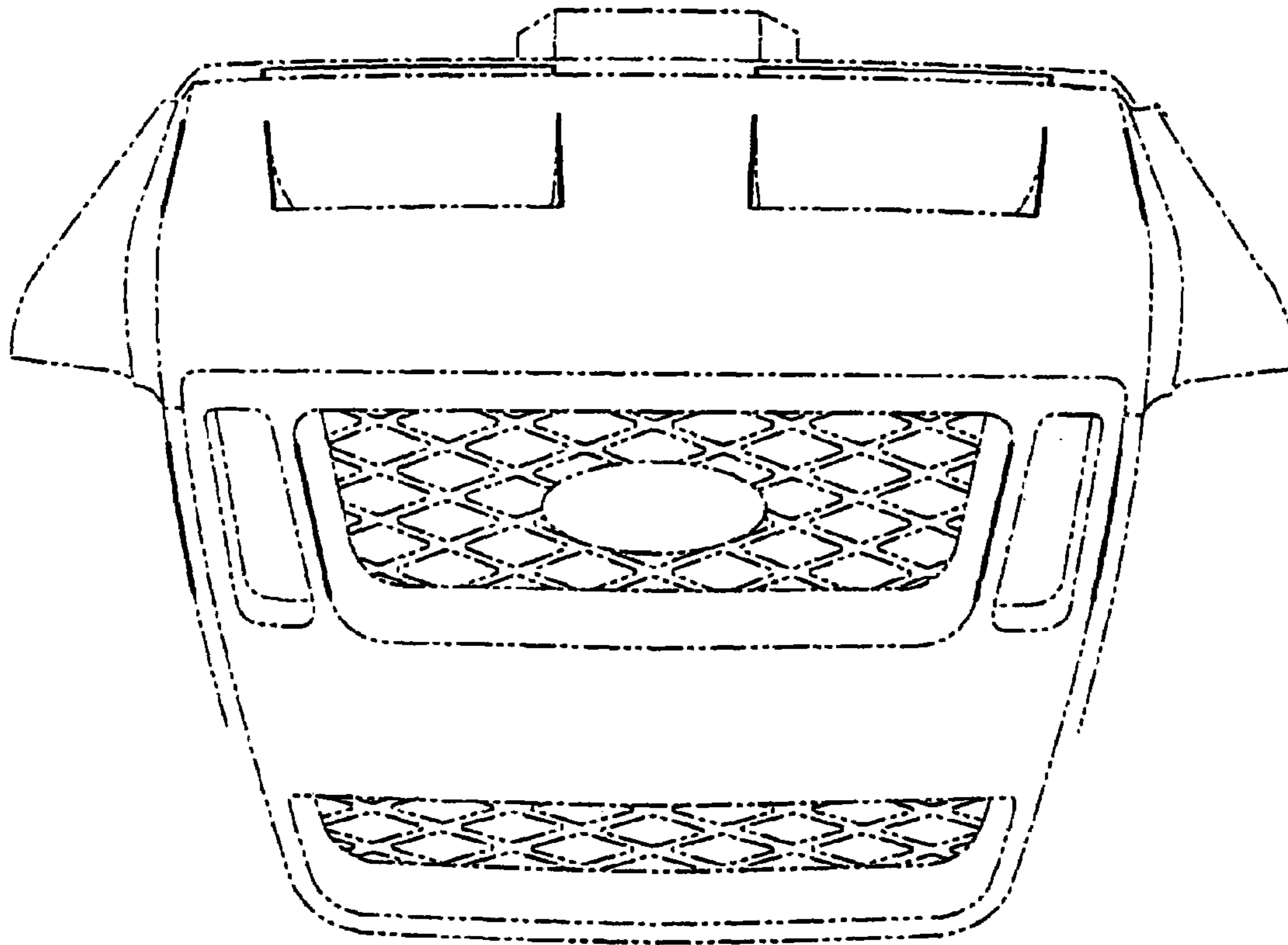

FIG - 7

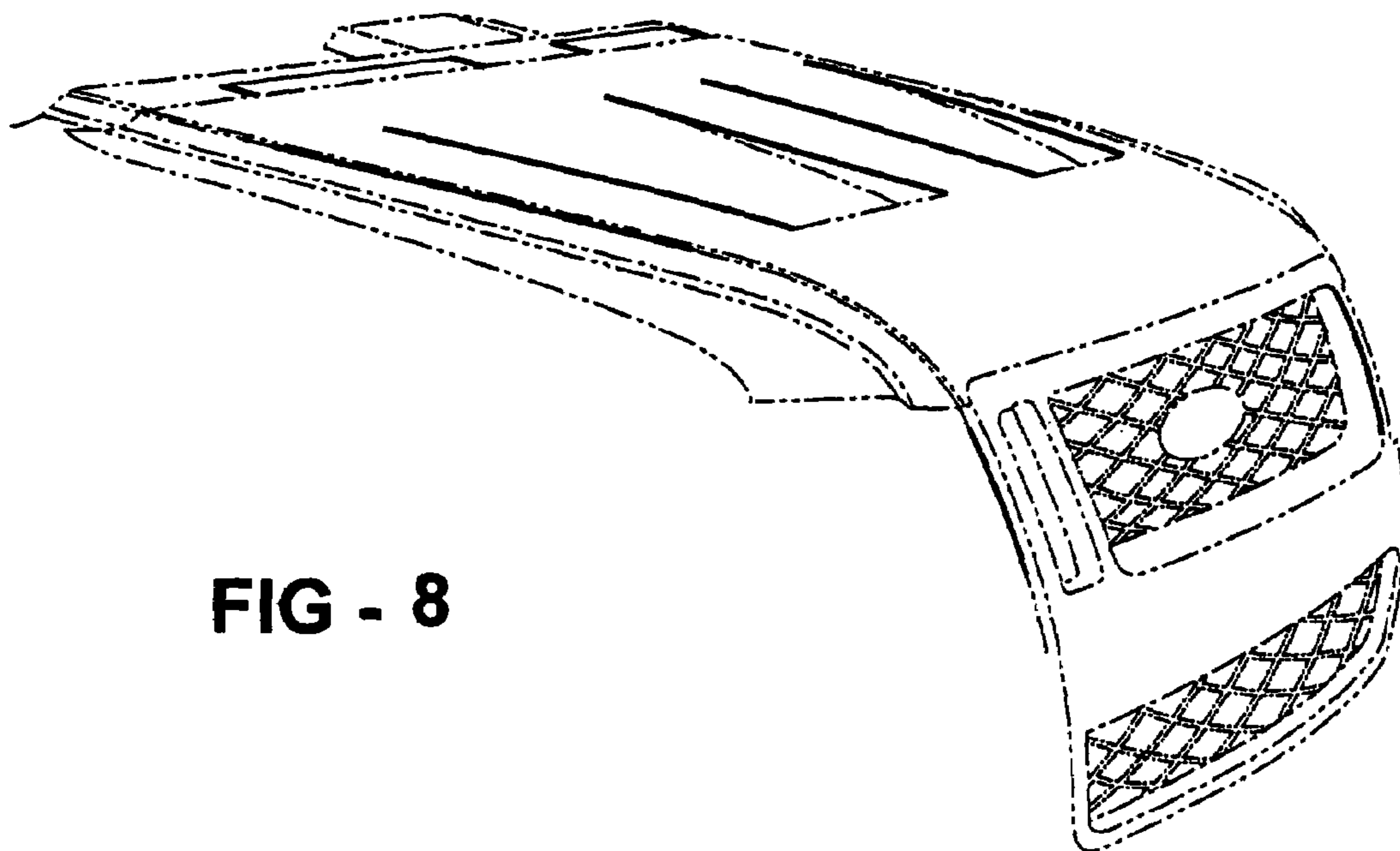

FIG - 8