



US00D572642S

(12) **United States Design Patent**  
**Steckling et al.**

(10) **Patent No.:** **US D572,642 S**  
(45) **Date of Patent:** **\*\* Jul. 8, 2008**

(54) **WINDSHIELD**

2006/0065411 A1 3/2006 Linsmeier et al.  
2006/0180322 A1 8/2006 Archer et al.

(75) Inventors: **Scott L. Steckling**, Neenah, WI (US);  
**Jason M. Ollanketo**, Oshkosh, WI (US);  
**Travis L. McCormick**, Appleton, WI  
(US); **Eric W. Kubalek**, Oshkosh, WI  
(US)

(73) Assignee: **Oshkosh Truck Corporation**, Oshkosh,  
WI (US)

(\*\*) Term: **14 Years**

(21) Appl. No.: **29/249,494**

(22) Filed: **Oct. 9, 2006**

(51) **LOC (8) Cl.** ..... **12-16**  
(52) **U.S. Cl.** ..... **D12/182**  
(58) **Field of Classification Search** ..... D12/40,  
D12/82, 84, 99, 182-183; D21/424, 433;  
219/84.1, 96.19, 97.1, 95.1, 178; 160/370.21;  
280/424

See application file for complete search history.

(56) **References Cited**

**U.S. PATENT DOCUMENTS**

|                 |         |                             |        |
|-----------------|---------|-----------------------------|--------|
| D198,526 S *    | 6/1964  | Nallinger .....             | D12/84 |
| D248,033 S *    | 5/1978  | James et al. ....           | D12/84 |
| D254,609 S *    | 4/1980  | Neal et al. ....            | D12/84 |
| D255,340 S *    | 6/1980  | Flesche .....               | D12/84 |
| D305,623 S *    | 1/1990  | Gallitzendoerfer et al. ... | D12/84 |
| D363,258 S *    | 10/1995 | Calce .....                 | D12/84 |
| 5,501,567 A     | 3/1996  | Lanzdorf et al.             |        |
| D376,562 S *    | 12/1996 | Sealy et al. ....           | D12/84 |
| D425,826 S *    | 5/2000  | Hellhake et al. ....        | D12/96 |
| D442,888 S *    | 5/2001  | Papke et al. ....           | D12/84 |
| D465,177 S *    | 11/2002 | Daurelle et al. ....        | D12/84 |
| D466,050 S *    | 11/2002 | Forey et al. ....           | D12/84 |
| D503,126 S *    | 3/2005  | Papke et al. ....           | D12/84 |
| 6,883,815 B2    | 4/2005  | Archer                      |        |
| 7,073,847 B2    | 7/2006  | Morrow et al.               |        |
| 7,207,582 B2    | 4/2007  | Siebers et al.              |        |
| 2005/0253344 A1 | 11/2005 | Trinkner et al.             |        |
| 2006/0037760 A1 | 2/2006  | Froland et al.              |        |

**OTHER PUBLICATIONS**

Rosco, Integrastyle School Bus Mirrors, undated.  
Pierce, QUANTUM® Chassis, bearing a designation "© 2005 Pierce Manufacturing Inc."  
Pierce, Arrow XT Chassis, bearing a designation "© 2006 Pierce Manufacturing Inc."  
Pierce, LANCE® Chassis, bearing a designation "© 2005 Pierce Manufacturing Inc."  
Pierce, ENFORCER® Chassis, bearing a designation "© 2005 Pierce Manufacturing Inc."  
Pierce, Pumpers, bearing a designation "8/06".  
Pierce, Custom Chassis, bearing a designation "8/06".  
Mainstreet, vol. 3, No. 1, Spring 2005.

\* cited by examiner

*Primary Examiner*—Caron D. Veynar  
*Assistant Examiner*—Abraham Bahta  
(74) *Attorney, Agent, or Firm*—Foley & Lardner LLP

(57) **CLAIM**

We claim the ornamental design for a windshield, as shown and described.

**DESCRIPTION**

FIG. 1 is a perspective view of a windshield showing our new design;  
FIG. 2 is a front view thereof;  
FIG. 3 is a right side view; the left side being a mirror image thereof;  
FIG. 4 is a bottom view thereof;  
FIG. 5 is a top view thereof; and,  
FIG. 6 is a rear view thereof.  
The ornamental design which is claimed is shown in solid lines in the drawings. The broken lines in the drawings are for illustrative purposes only and form no part of the claimed design.

**1 Claim, 6 Drawing Sheets**

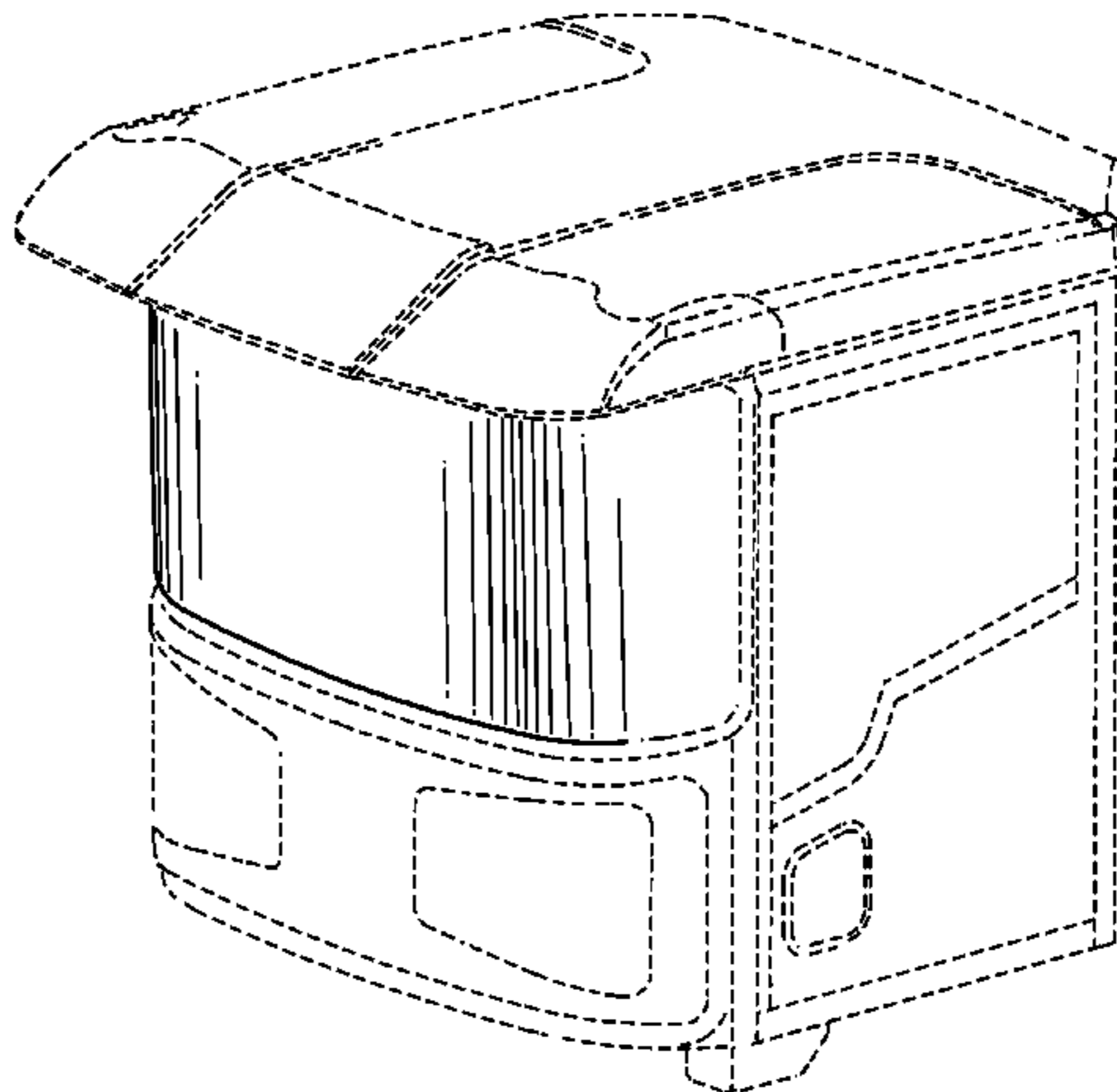

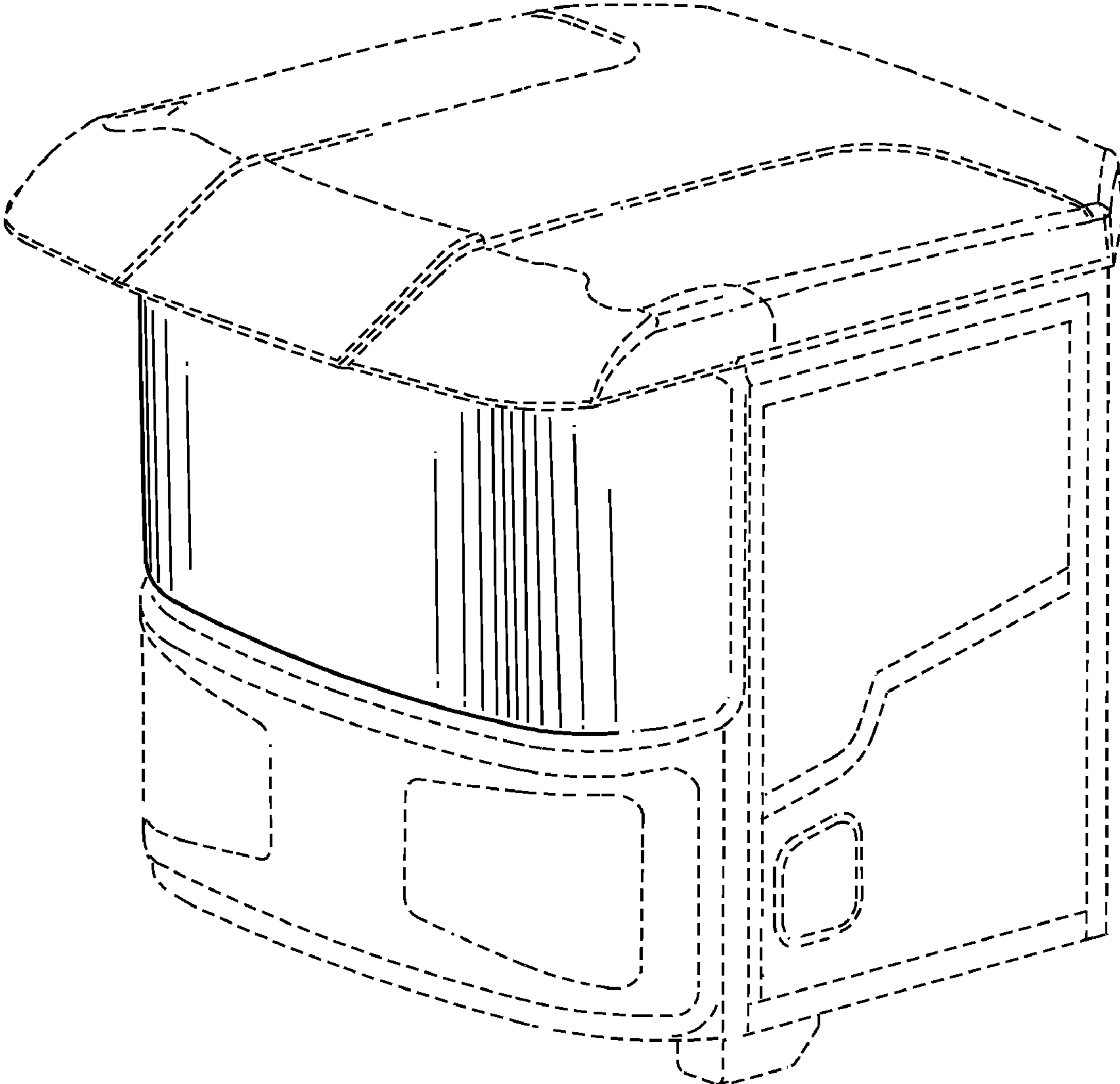

FIG. 1

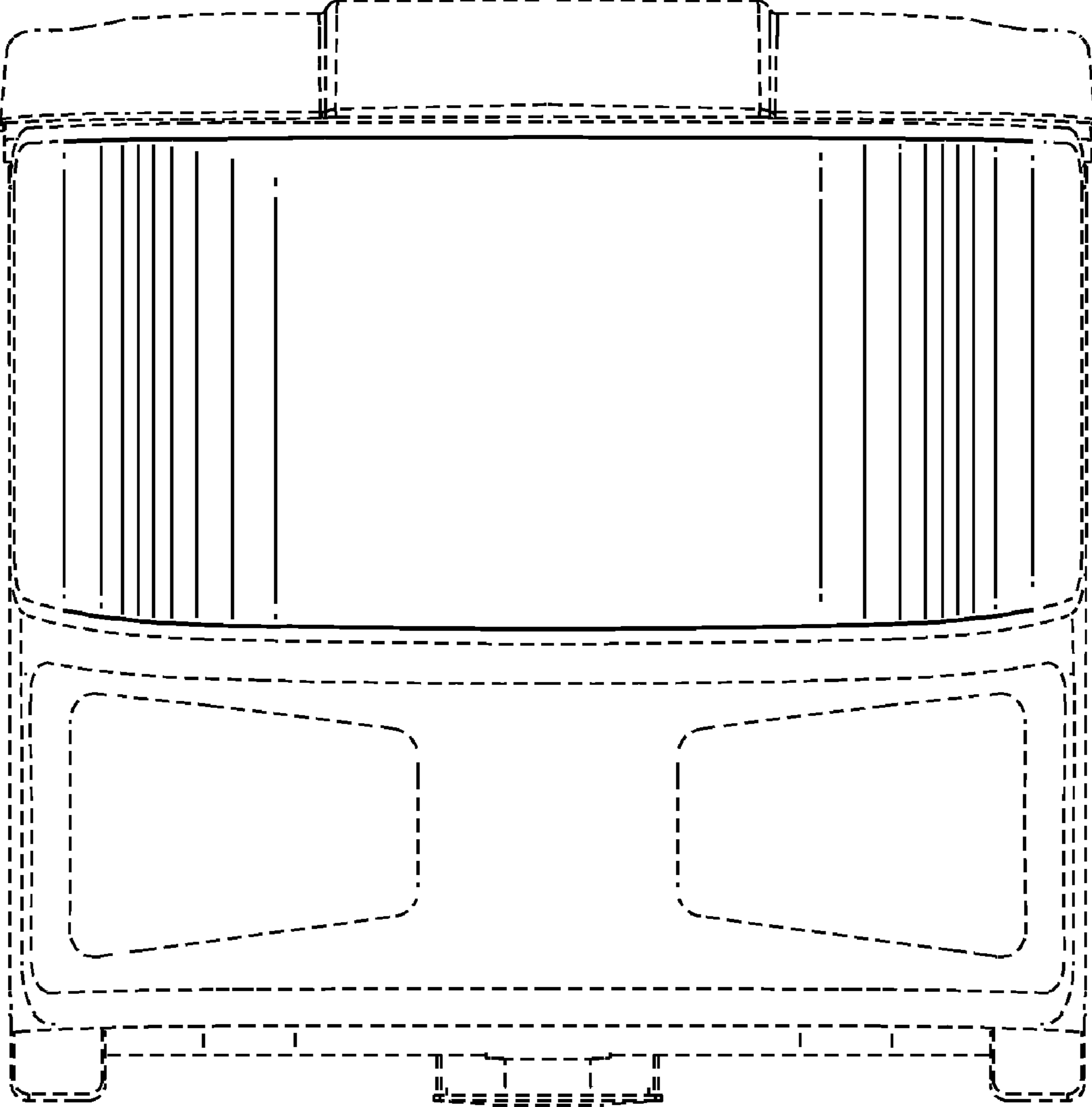

FIG. 2

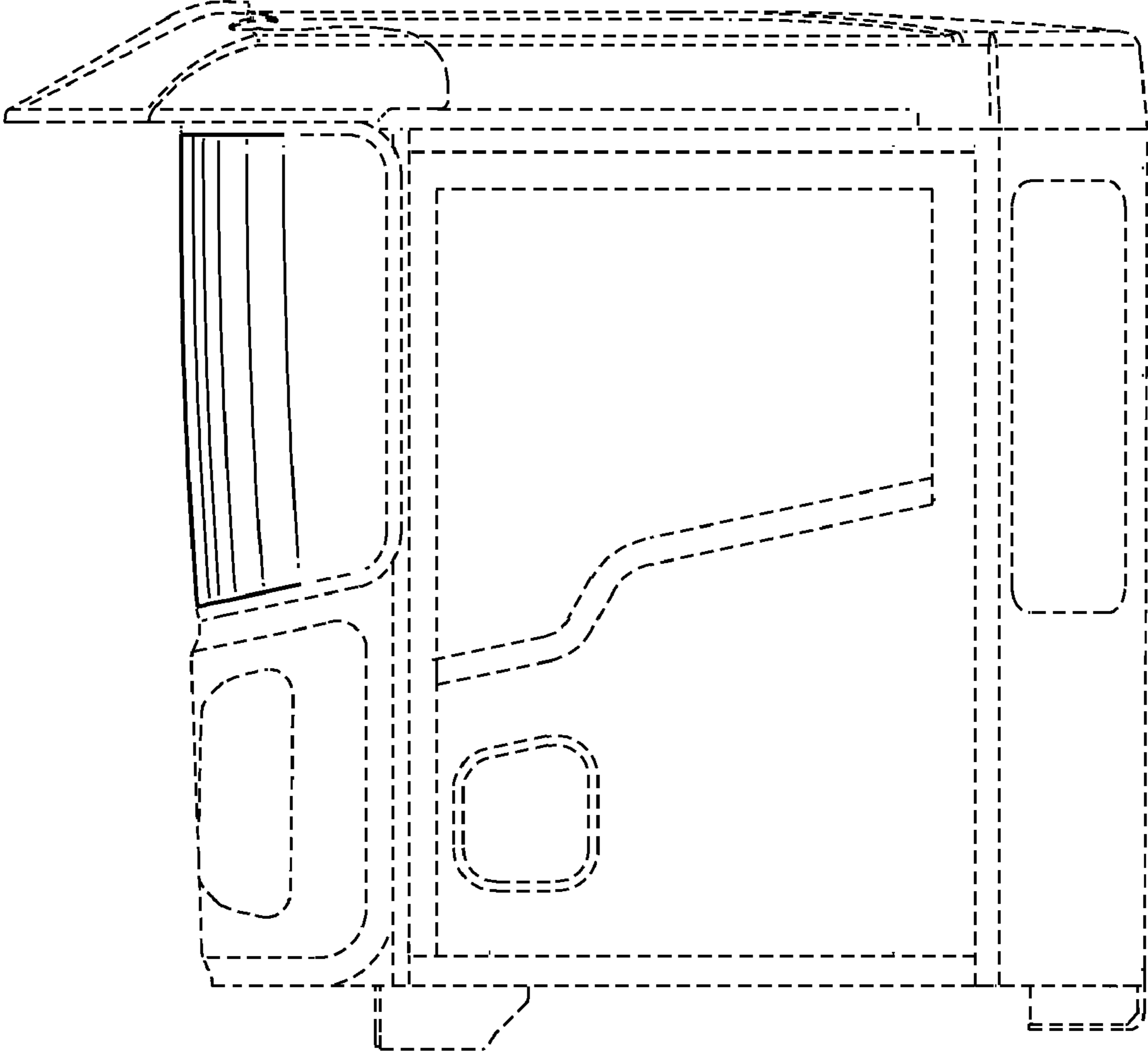

FIG. 3

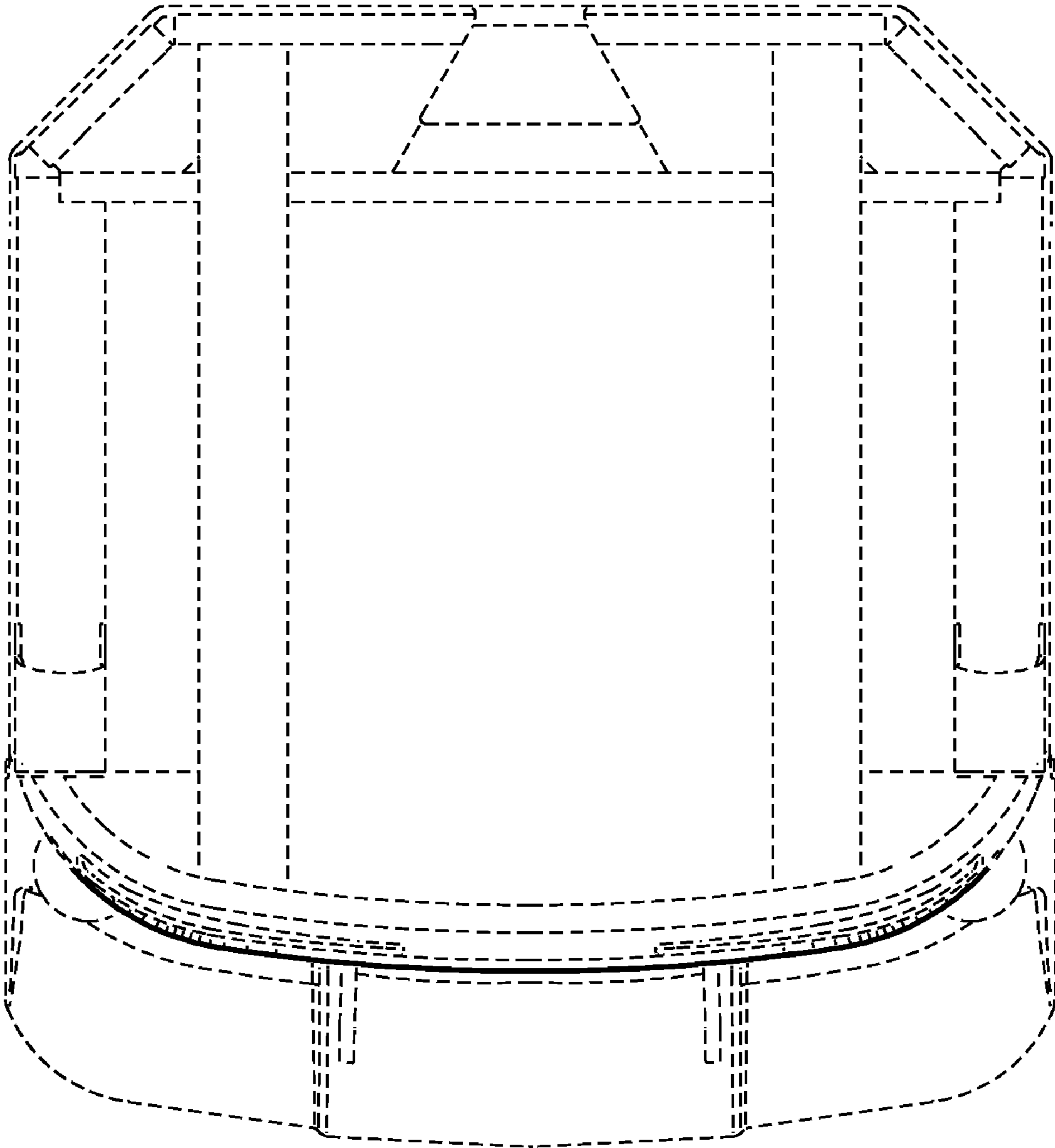

FIG. 4

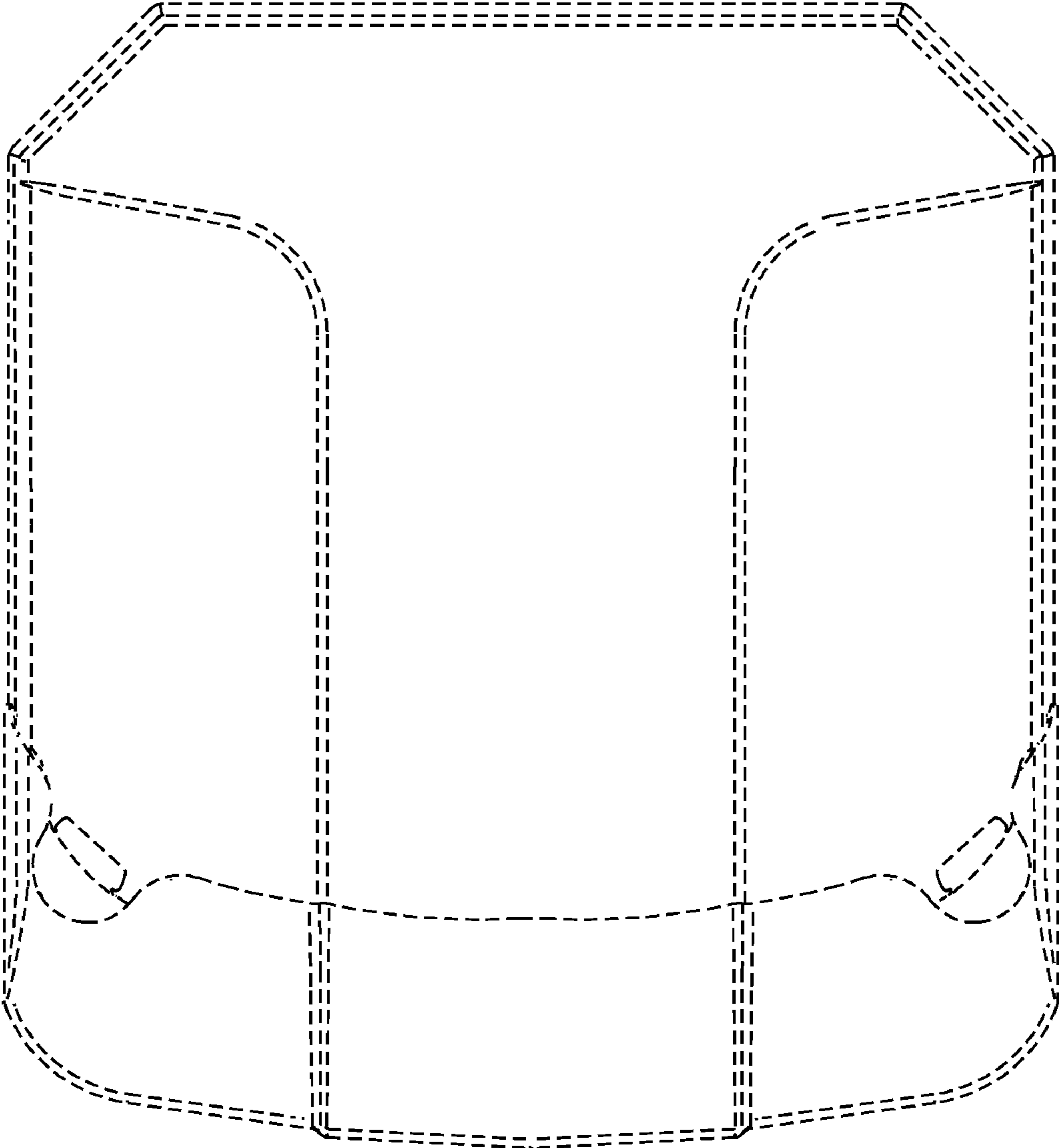

FIG. 5

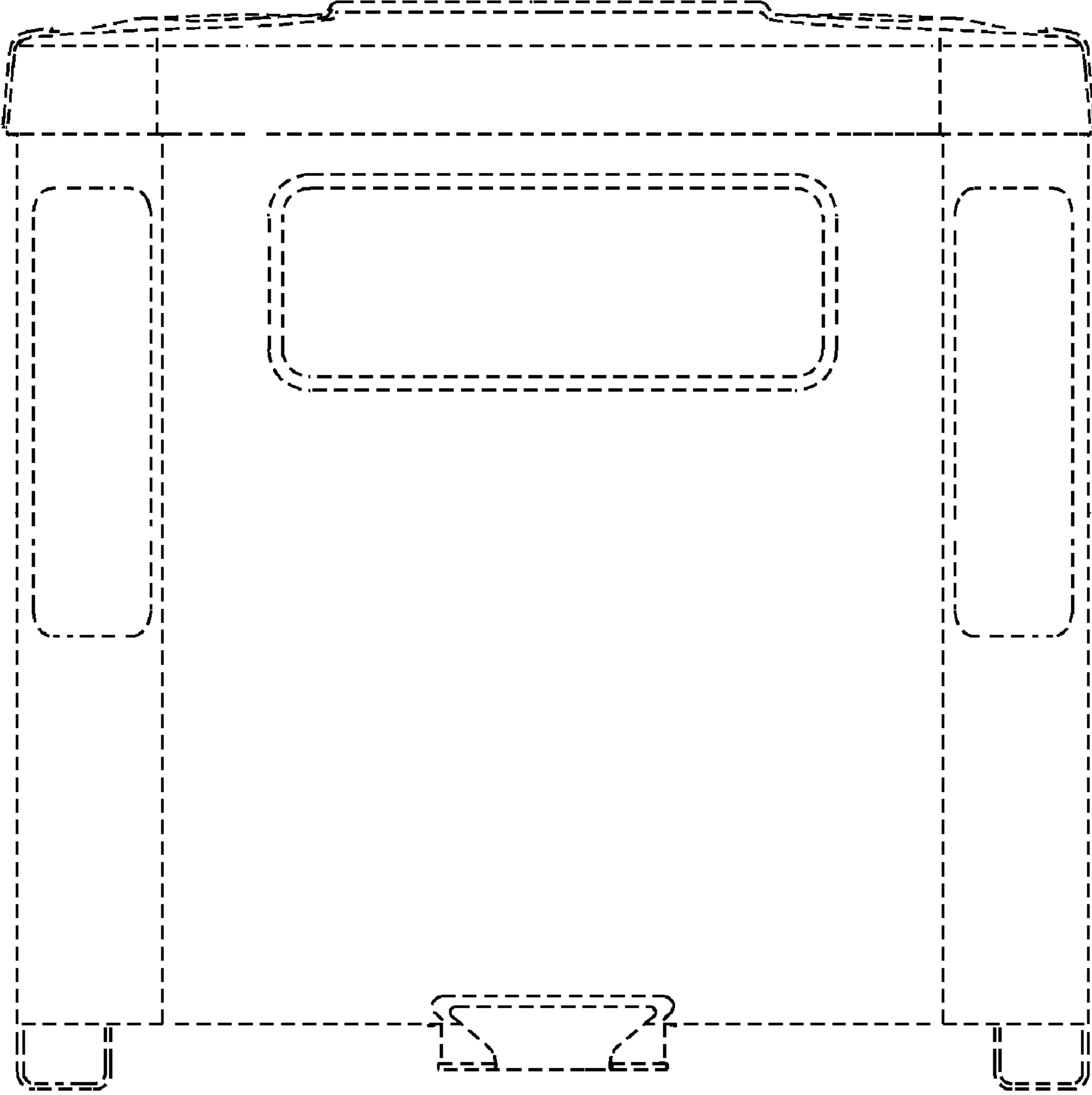

FIG. 6