



US00D572529S

(12) **United States Design Patent**
Crookshanks et al.

(10) **Patent No.:** **US D572,529 S**
(45) **Date of Patent:** **** Jul. 8, 2008**

(54) **PORTION OF AN APPLIANCE**

(75) Inventors: **Kent Allen Stephen Crookshanks**,
Anderson, SC (US); **Daniel Hartley**
Green, Nashville, TN (US)

(73) Assignee: **Electrolux Home Products, Inc.**,
Cleveland, OH (US)

(**) Term: **14 Years**

(21) Appl. No.: **29/297,570**

(22) Filed: **Nov. 14, 2007**

(51) **LOC (8) Cl.** **07-02**

(52) **U.S. Cl.** **D7/405**

(58) **Field of Classification Search** D7/339–341,
D7/346–349, 402, 405, 406; 126/21 A, 21 R,
126/39 B, 273 A; 219/391–394
See application file for complete search history.

(56) **References Cited**

U.S. PATENT DOCUMENTS

| | | | | | |
|------------|---|---------|------------------|-------|--------|
| D464,229 S | * | 10/2002 | Baldwin et al. | | D7/340 |
| D470,720 S | * | 2/2003 | Jones et al. | | D7/405 |
| D477,177 S | * | 7/2003 | Jeong | | D7/340 |
| D477,496 S | * | 7/2003 | Monguilod et al. | | D7/340 |
| D491,411 S | * | 6/2004 | De Mello | | D7/340 |
| D495,918 S | * | 9/2004 | De Mello | | D7/340 |
| D510,227 S | * | 10/2005 | Baldwin | | D7/340 |

| | | | | | |
|------------|---|---------|----------------|-------|--------|
| D511,925 S | * | 11/2005 | Baldwin | | D7/340 |
| D521,317 S | * | 5/2006 | Hessen et al. | | D7/405 |
| D530,152 S | * | 10/2006 | Pryor | | D7/405 |
| D536,208 S | * | 2/2007 | Ostlund et al. | | D7/340 |
| D536,568 S | * | 2/2007 | Ostlund et al. | | D7/340 |
| D555,976 S | * | 11/2007 | Baldwin | | D7/405 |

* cited by examiner

Primary Examiner—Robert A. Delhanty

Assistant Examiner—Mark Cavanna

(74) *Attorney, Agent, or Firm*—Banner & Witcoff, Ltd.

(57) **CLAIM**

The ornamental design for a portion of an appliance, as shown and described.

DESCRIPTION

FIG. 1 is a front perspective view of a portion of an appliance showing our new design;

FIG. 2 is a front view thereof;

FIG. 3 is a right side view thereof;

FIG. 4 is a left side view thereof;

FIG. 5 is a top view thereof; and,

FIG. 6 is a bottom view thereof.

The broken line showing of various regions, including the unshaded areas therein, is for illustrative purposes and forms no part of the claimed design.

1 Claim, 5 Drawing Sheets

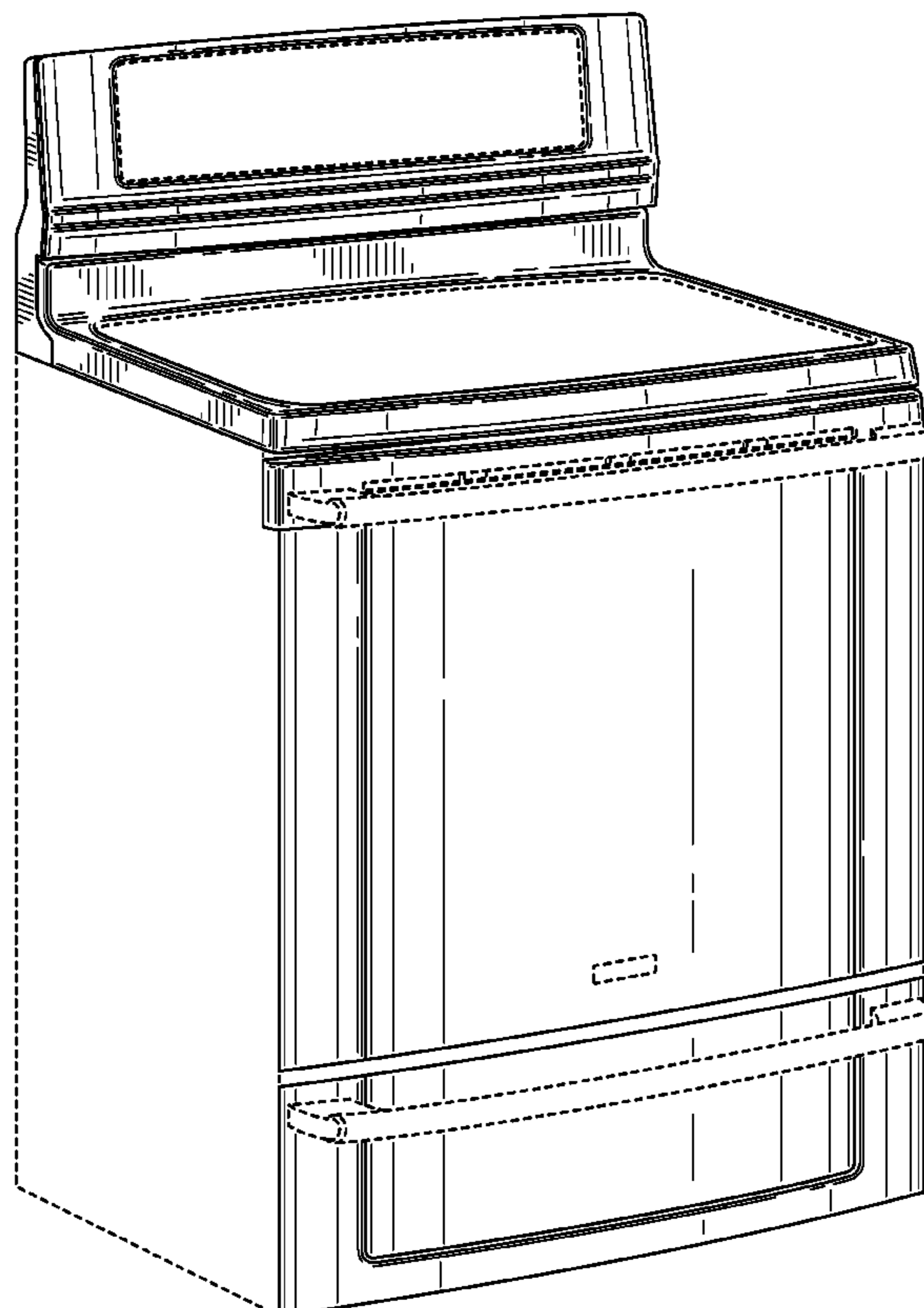

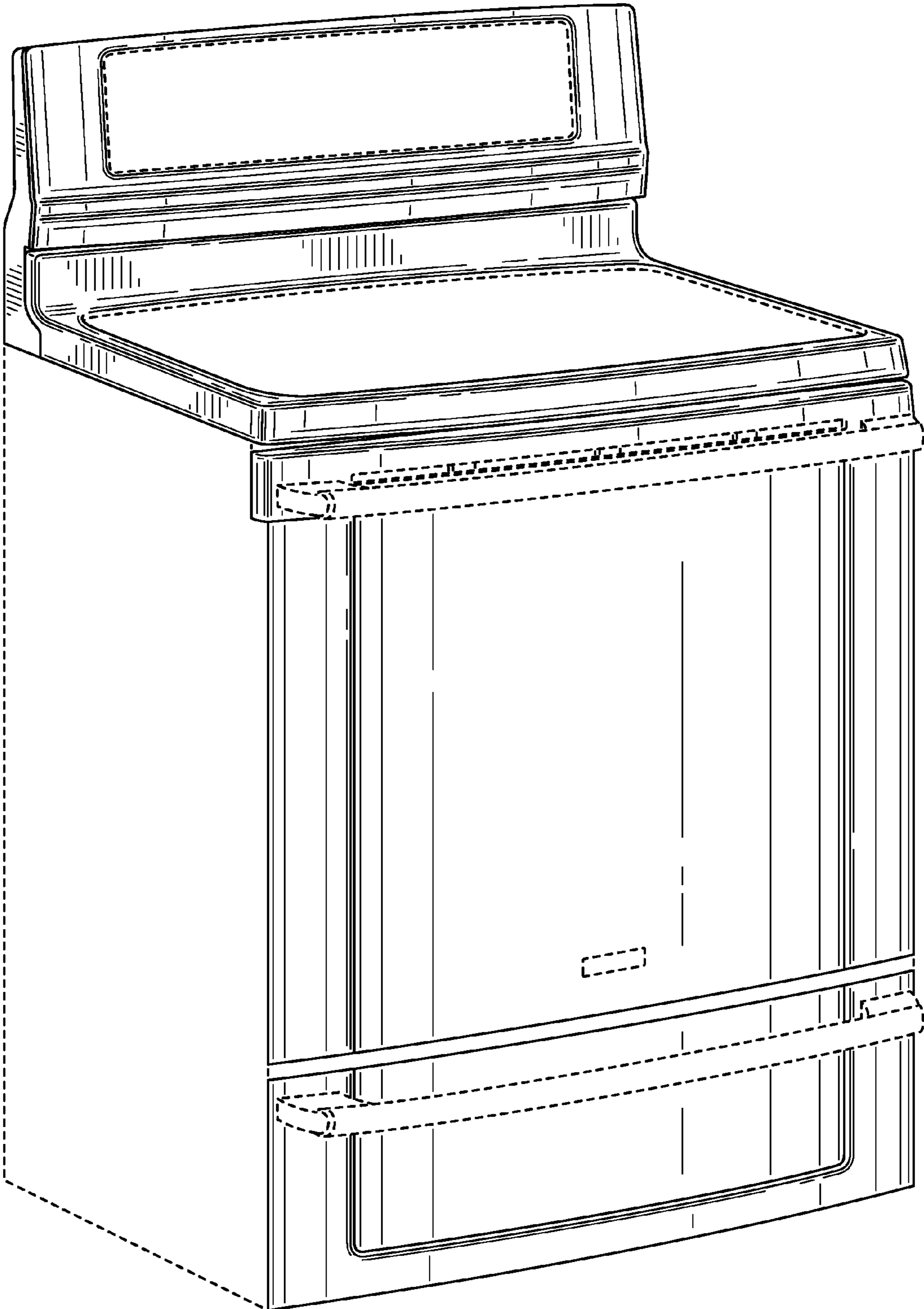

FIG. 1

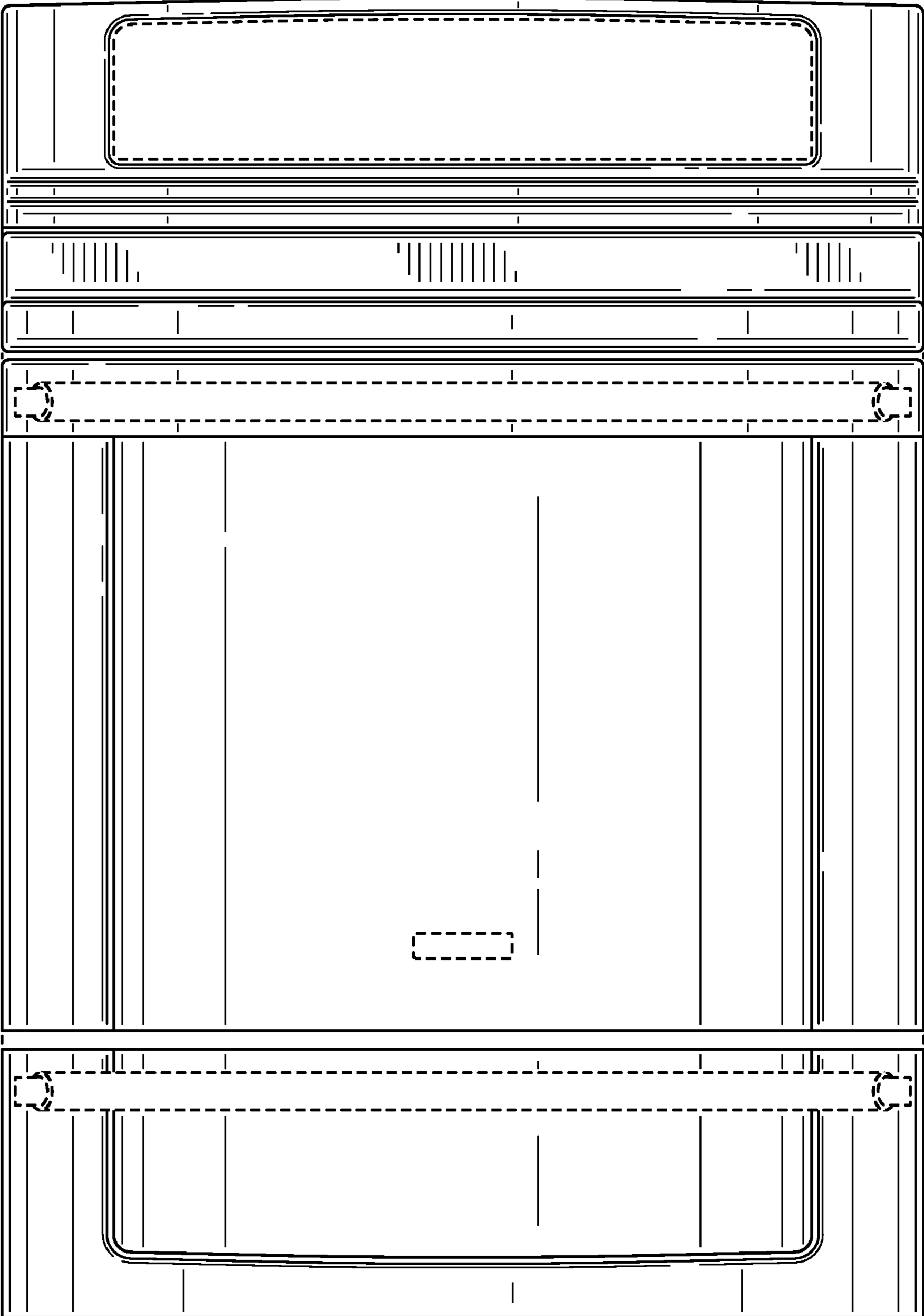

FIG. 2

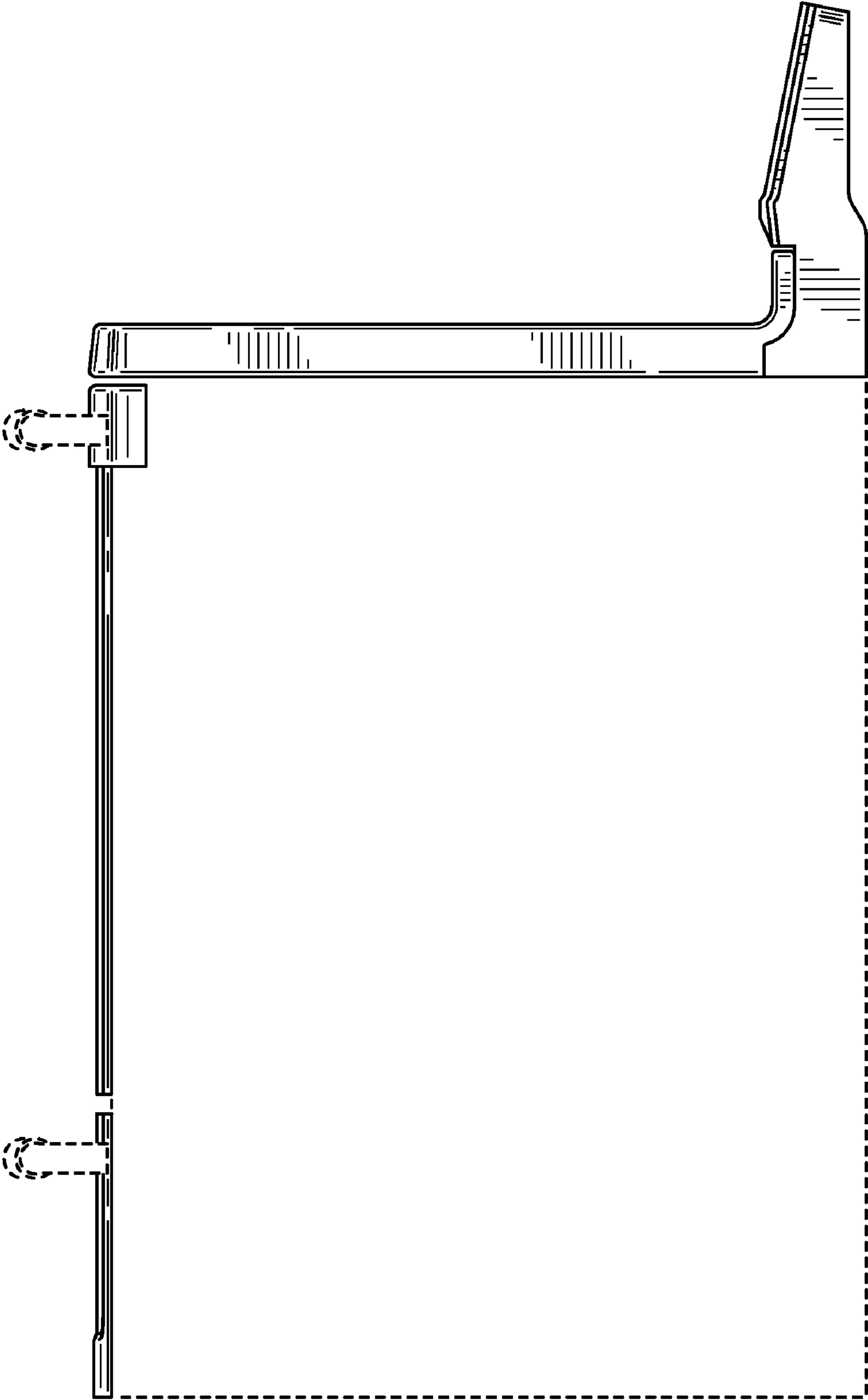

FIG. 3

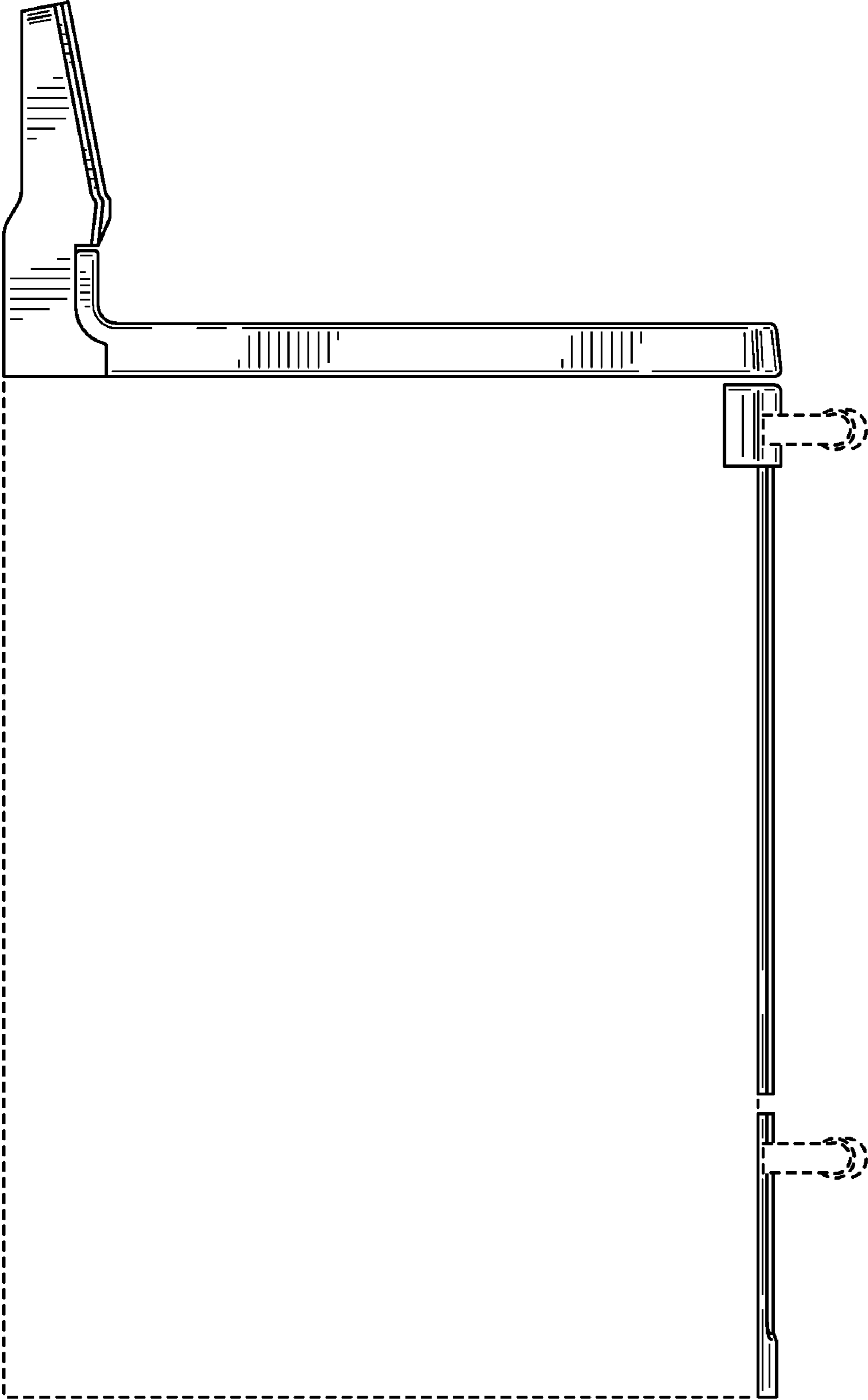

FIG. 4

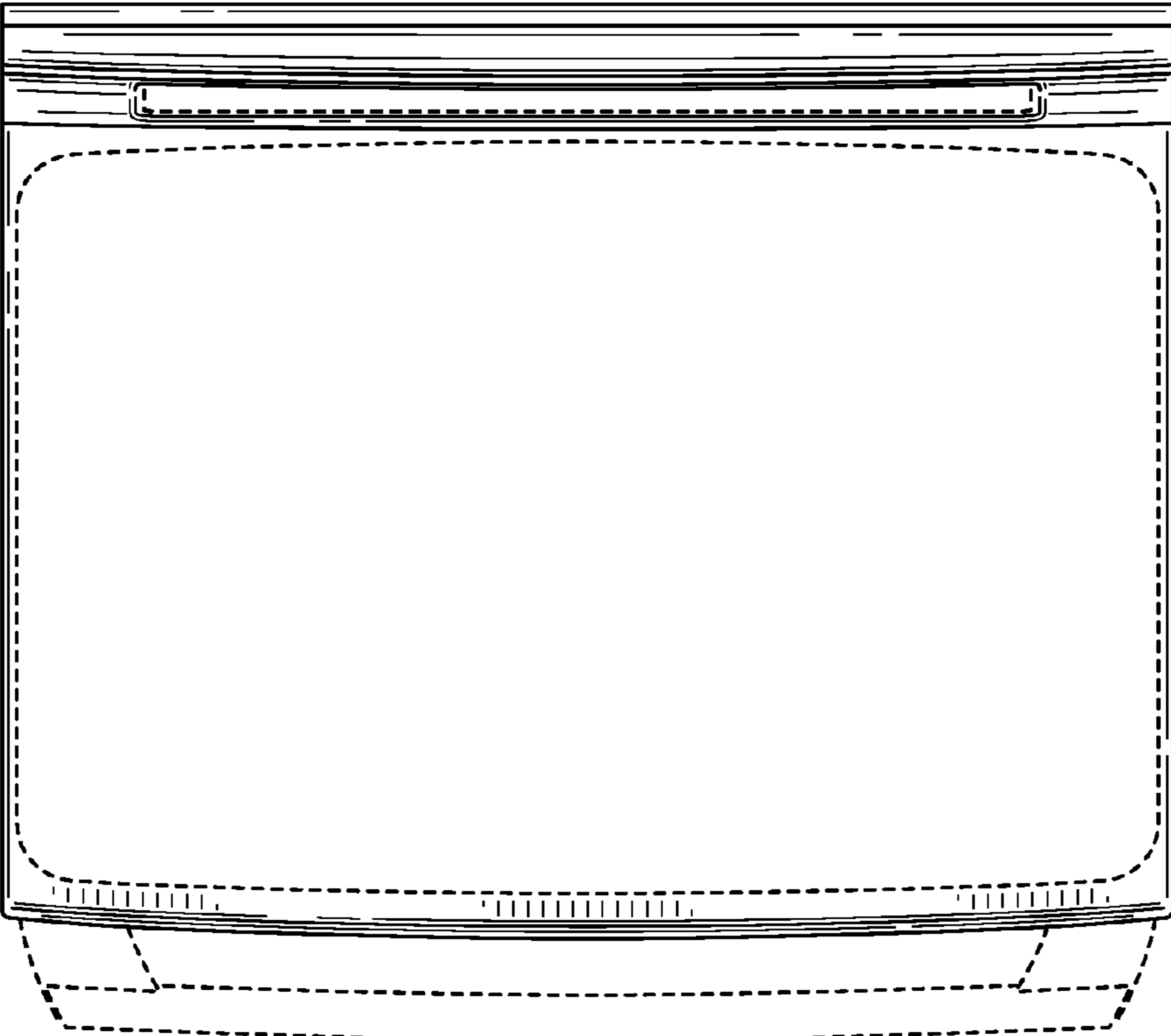

FIG. 5

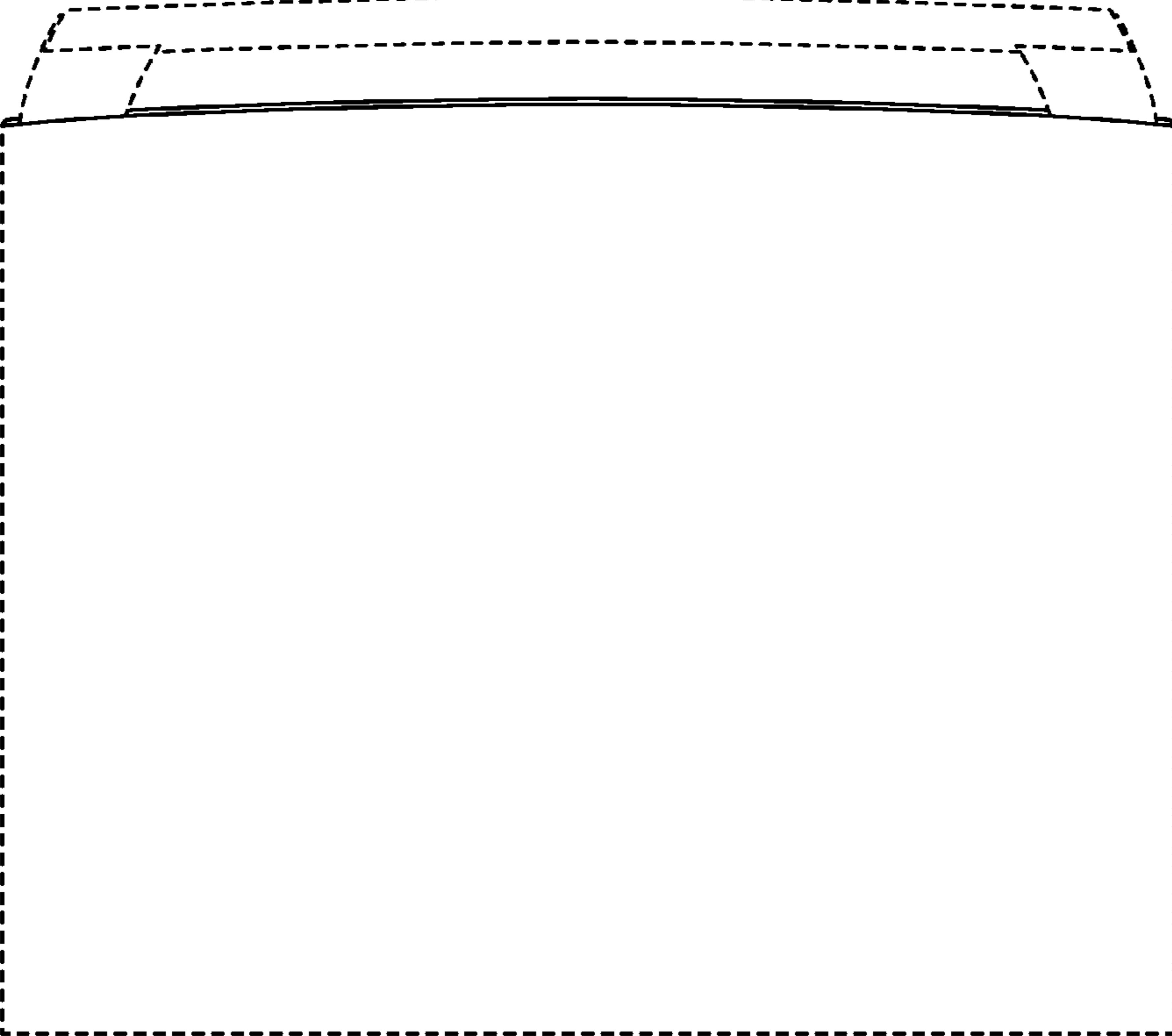

FIG. 6