



US00D572312S

(12) **United States Design Patent**  
**Stephenson, III et al.**

(10) **Patent No.:** **US D572,312 S**  
(45) **Date of Patent:** **\*\* Jul. 1, 2008**

(54) **SIGN FOR VEHICLES**

D524,378 S \* 7/2006 Salcido ..... D20/10  
7,178,715 B1 \* 2/2007 Dean ..... 232/38

(75) Inventors: **Orlando W. Stephenson, III**,  
Kentwood, MI (US); **David J. Looks**,  
Grand Rapids, MI (US); **Valerie K.**  
**Marquardt**, Wyoming, MI (US); **Jack J.**  
**Smit**, Saranac, MI (US)

\* cited by examiner

*Primary Examiner*—Caron D. Veynar  
*Assistant Examiner*—Mary Ann Calabrese  
(74) *Attorney, Agent, or Firm*—Price, Heneveld, Cooper,  
DeWitt & Litton, LLP

(73) Assignee: **SPEC International, Inc.**, Grand  
Rapids, MI (US)

(57) **CLAIM**

(\*\*) Term: **14 Years**

The ornamental design for a sign for vehicles, as shown and  
described.

(21) Appl. No.: **29/277,810**

(22) Filed: **Mar. 9, 2007**

**DESCRIPTION**

(51) **LOC (8) Cl.** ..... **20-03**

FIG. 1 is an isometric view of a sign for vehicles, showing our  
new design;

(52) **U.S. Cl.** ..... **D20/29; D99/31**

FIG. 2 is a front elevational view;

(58) **Field of Classification Search** ..... D20/10,

FIG. 3 is a rear elevational view;

D20/12, 15, 17, 19, 29, 99; 40/556, 566,

FIG. 4 is a top plan view;

40/572, 584, 588-592, 606.1, 607.13, 643,

FIG. 5 is a bottom plan view;

40/660.06; D10/109, 114; D26/28, 31; D99/29-31,

FIG. 6 is a right-hand side elevational view;

D99/33; 362/234, 235, 812; 232/34, 38,

FIG. 7 is a left-hand side elevational view;

232/39; 116/309

FIG. 8 is an isometric view of another embodiment of the sign  
for vehicles, showing our new design;

See application file for complete search history.

FIG. 9 is a front elevational view;

(56) **References Cited**

**U.S. PATENT DOCUMENTS**

3,242,329	A *	3/1966	Abrams	.....	362/235
4,149,333	A *	4/1979	Garfinkle	.....	40/606.1
4,662,095	A *	5/1987	Higgins	.....	40/592
D374,835	S *	10/1996	Wachter	.....	D10/114
5,711,100	A *	1/1998	Elmer	.....	40/592
5,797,673	A *	8/1998	Logan et al.	.....	362/234
D409,318	S *	5/1999	Hopkins et al.	.....	D26/31
5,918,397	A *	7/1999	Elmer	.....	40/592
6,014,942	A *	1/2000	Perka et al.	.....	116/309
D480,432	S *	10/2003	Newman	.....	D20/10
D508,538	S *	8/2005	Furr	.....	D20/10

FIG. 10 is a rear elevational view;

FIG. 11 is a top plan view; and

FIG. 12 is a bottom plan view.

FIG. 13 is a right-hand side elevational view; and,

FIG. 14 is a left-hand side elevational view.

In the drawings, the broken lines are for illustrative purposes  
only and form no part of the claimed design.

**1 Claim, 12 Drawing Sheets**

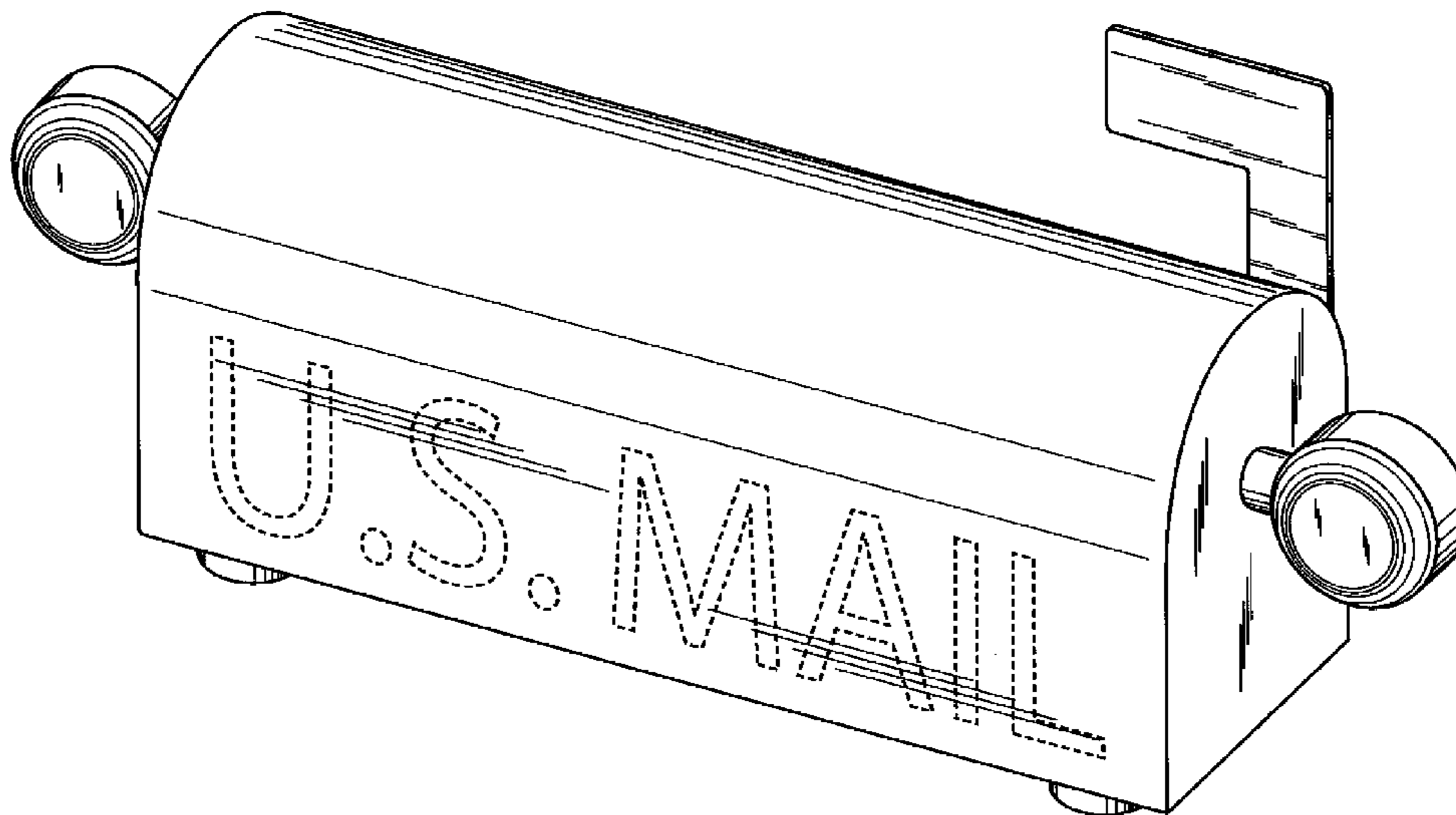

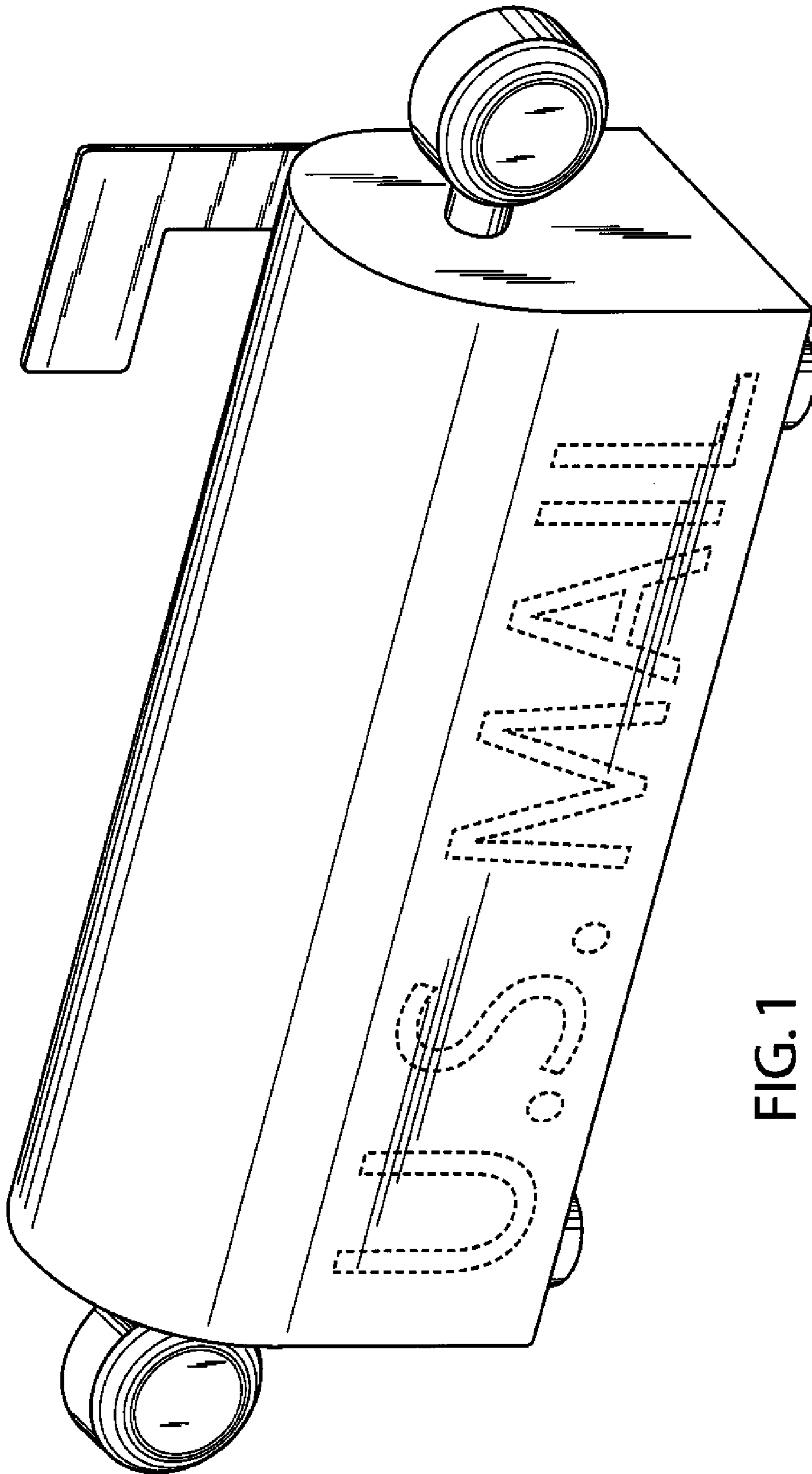

FIG. 1

FIG. 2

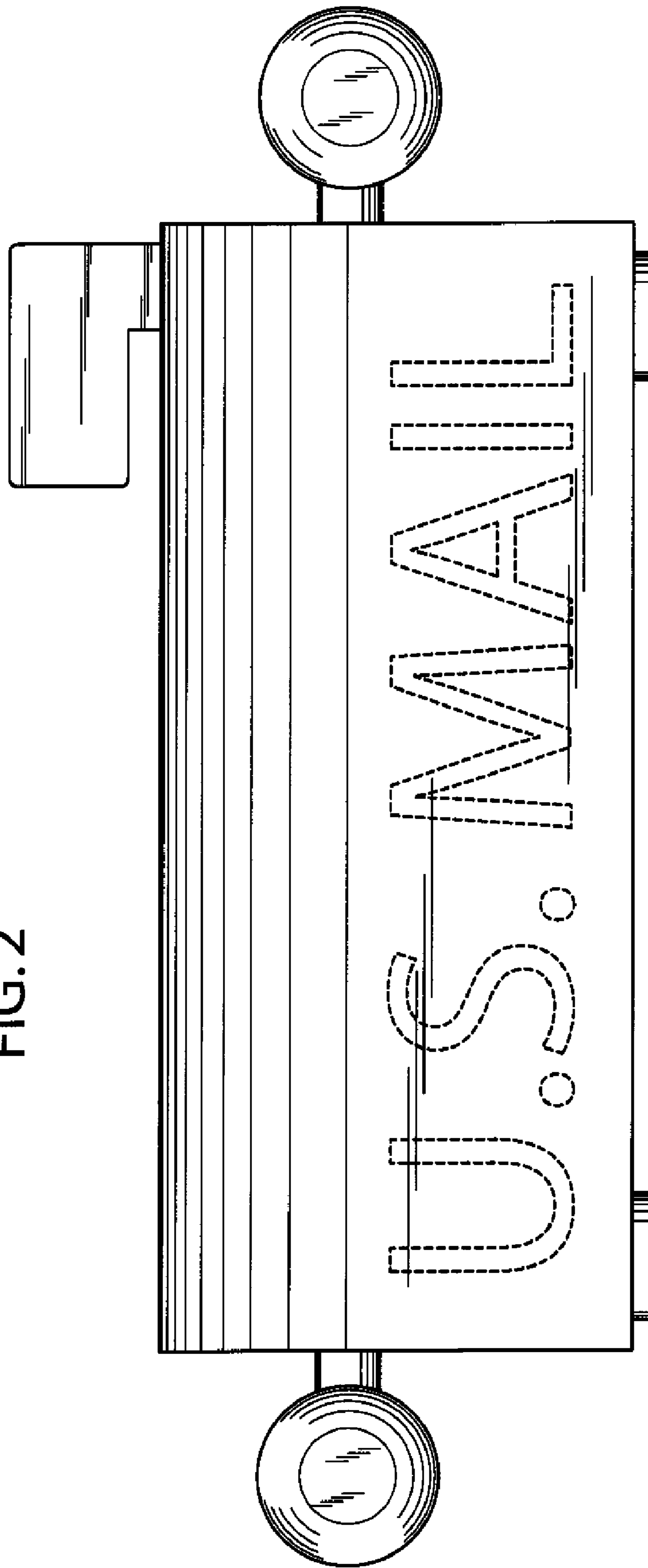

FIG. 3

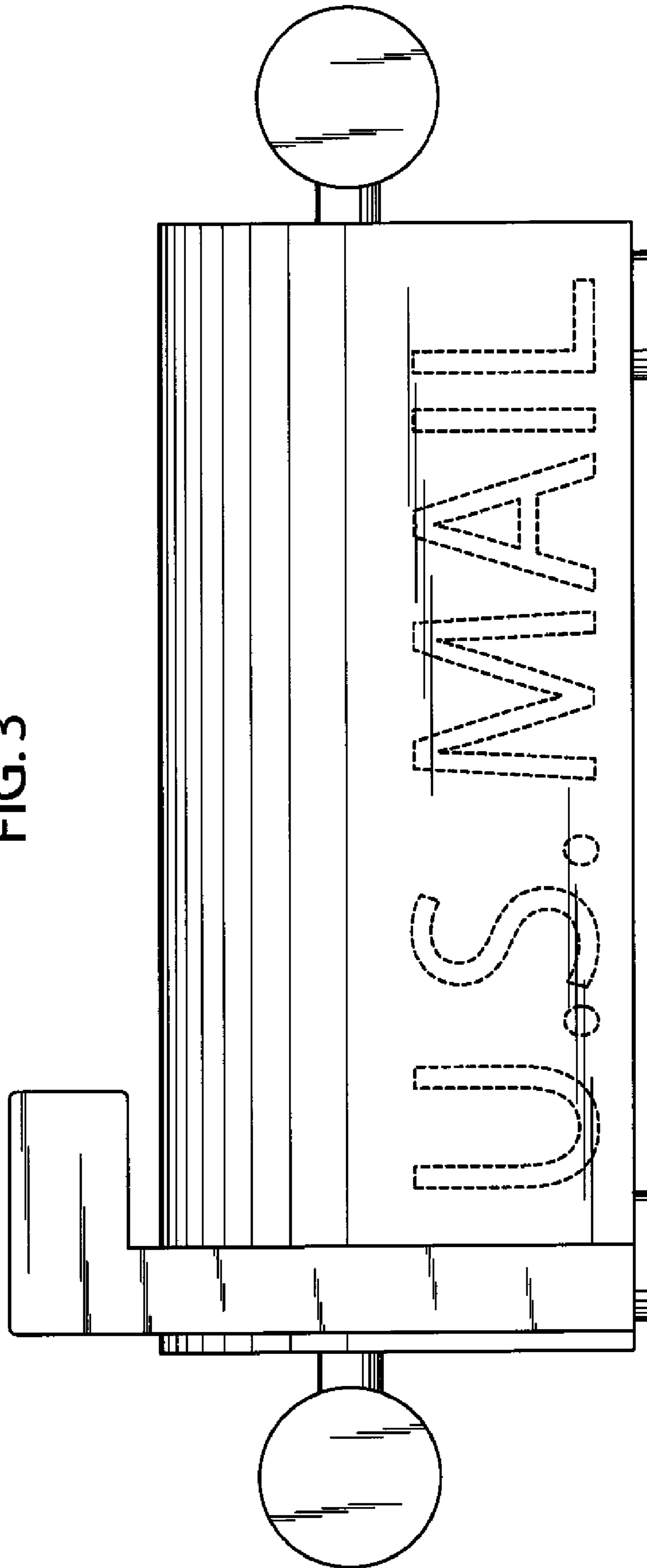

FIG. 4

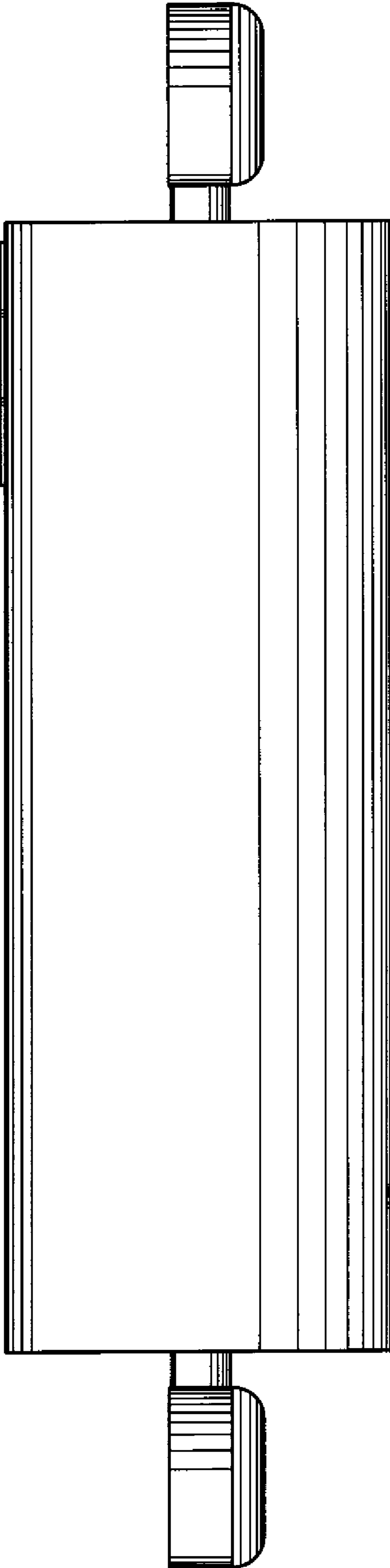
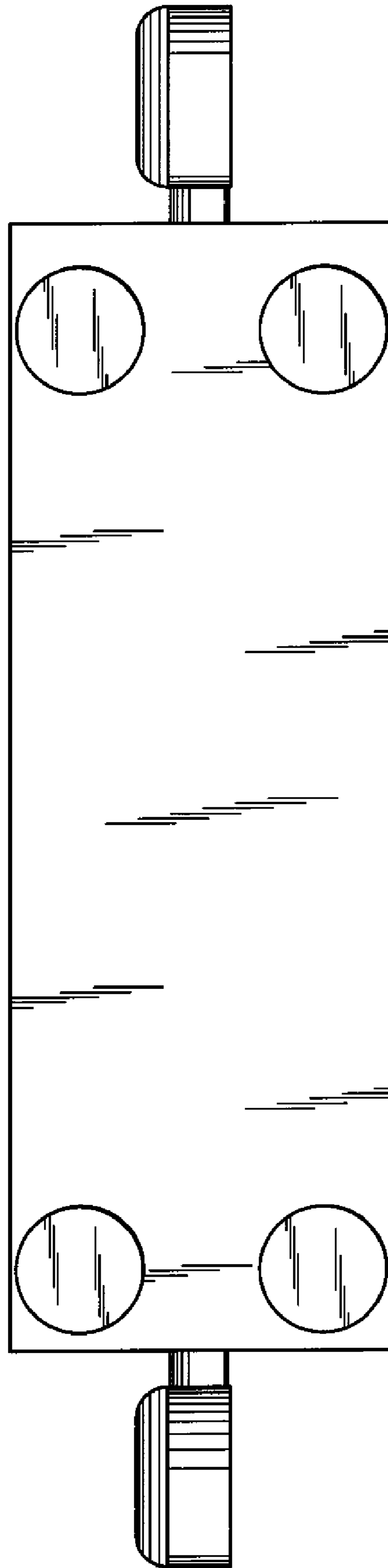

FIG. 5



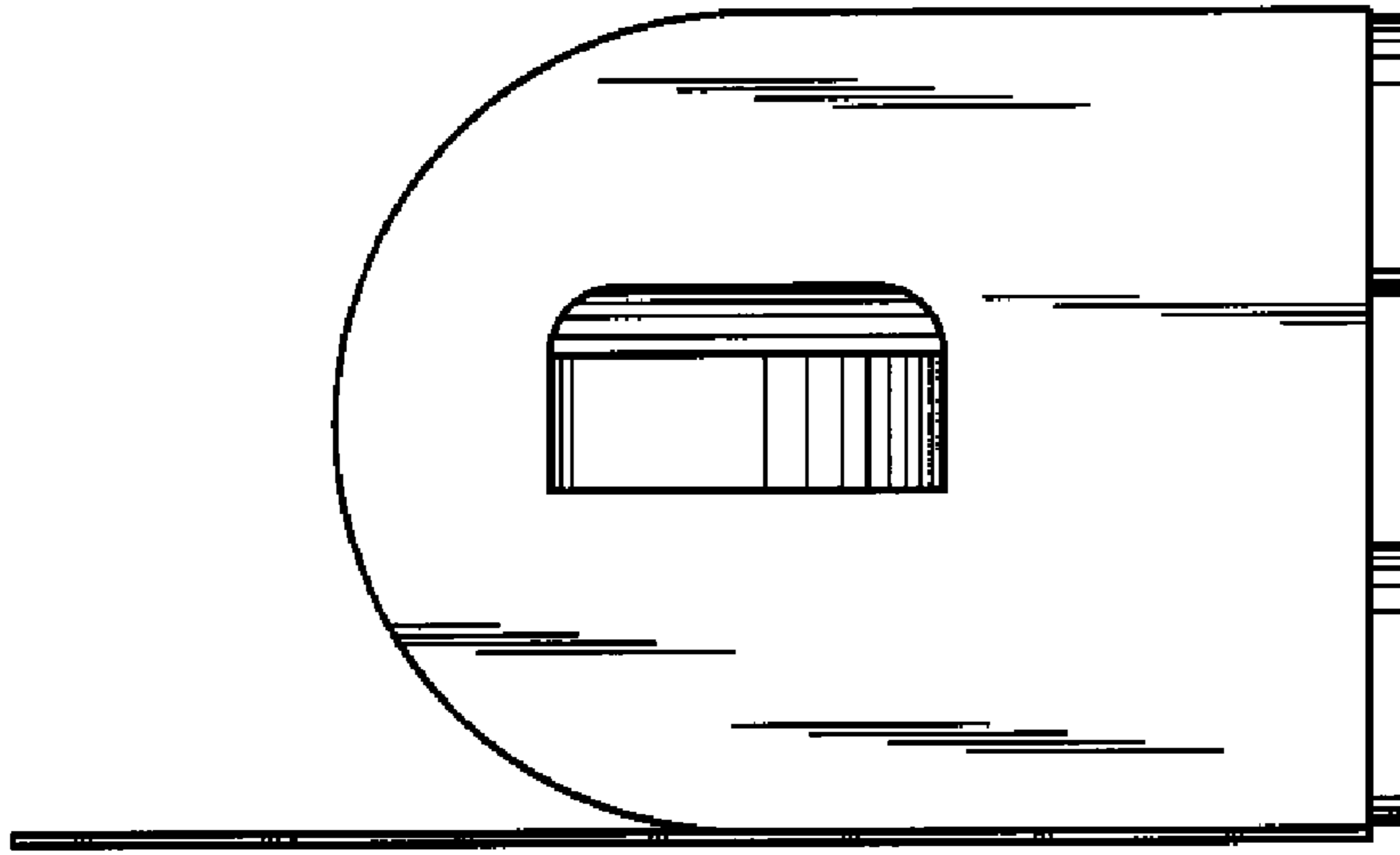

FIG. 6

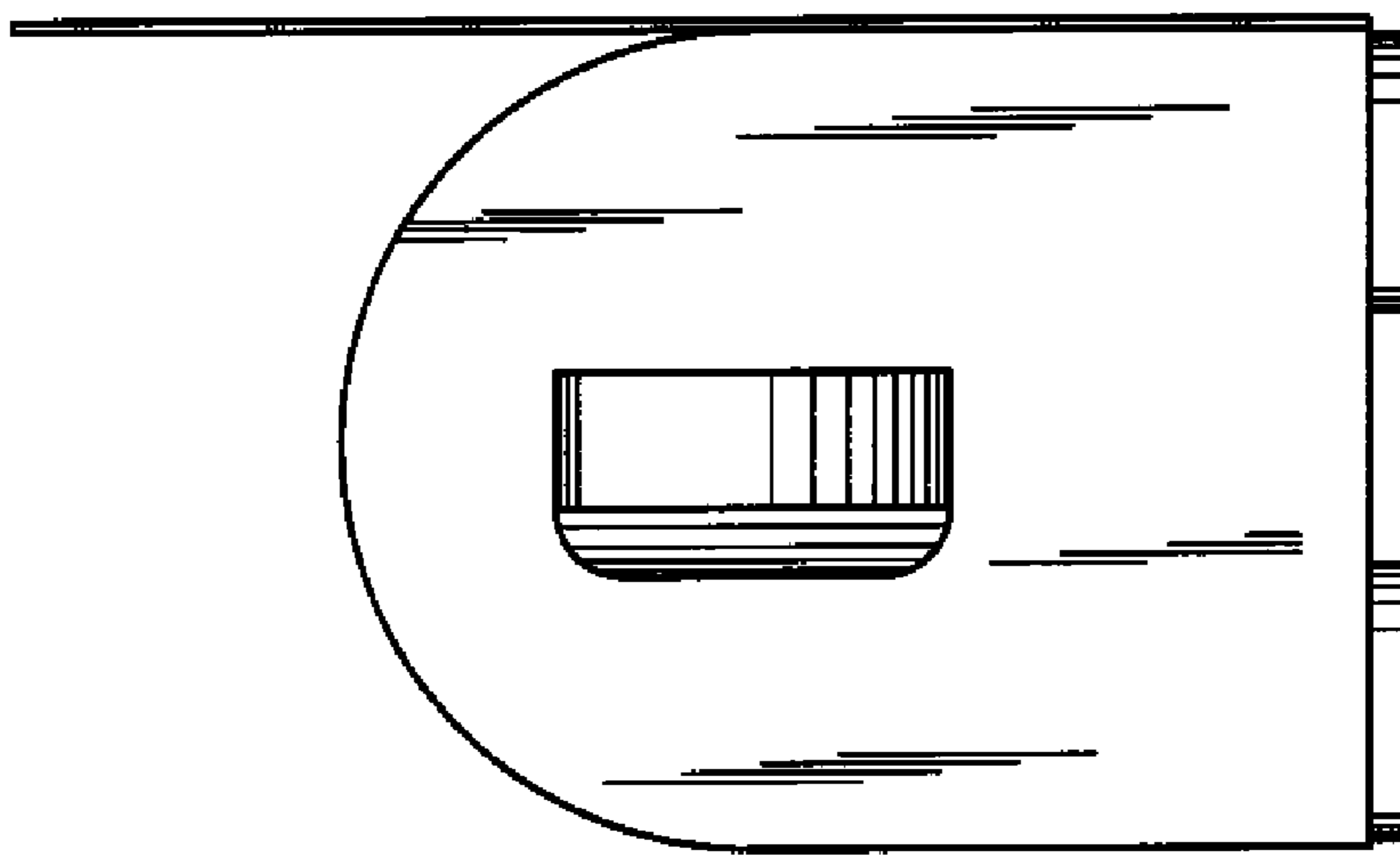

FIG. 7

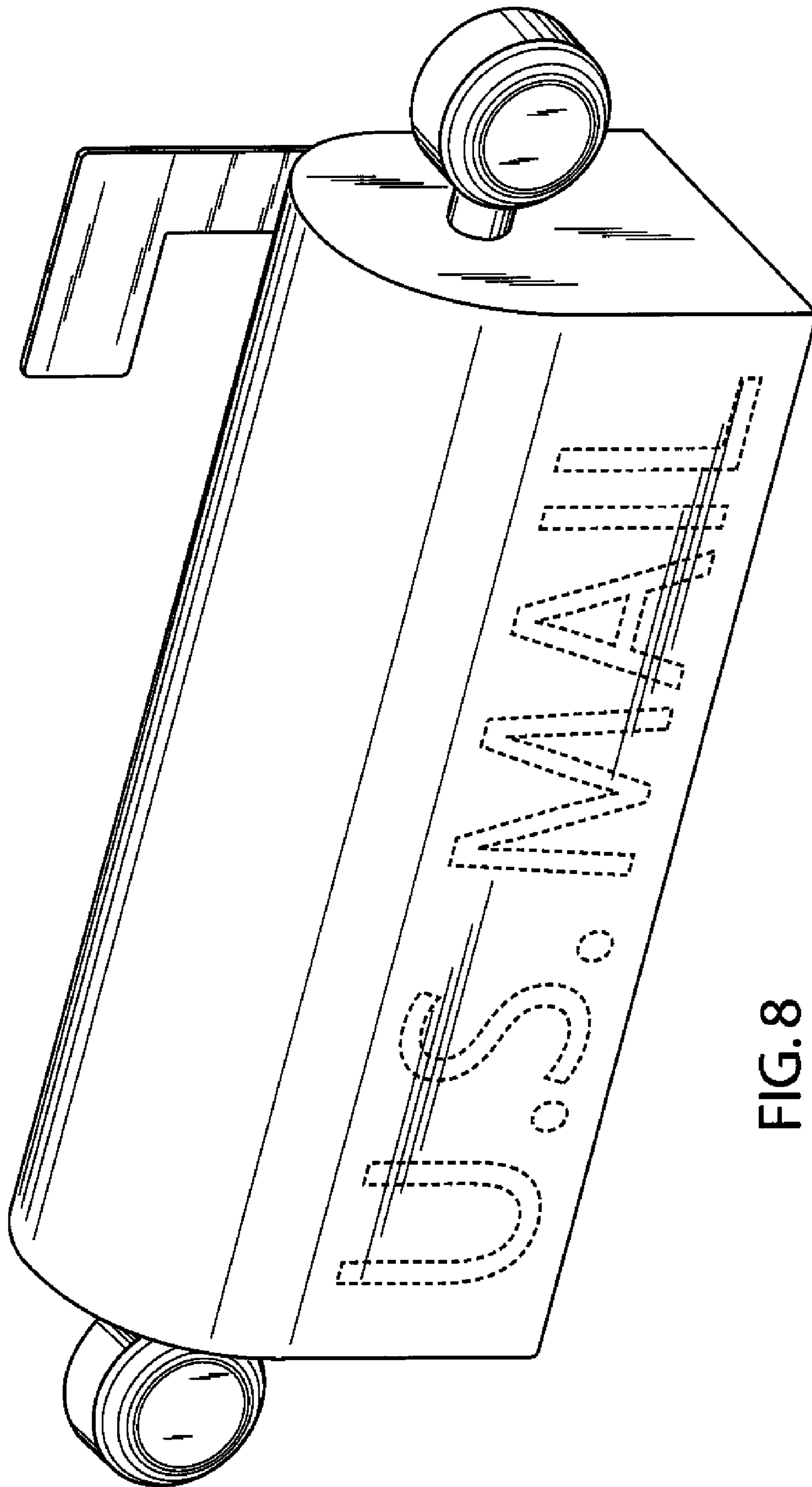

FIG. 8



FIG. 9

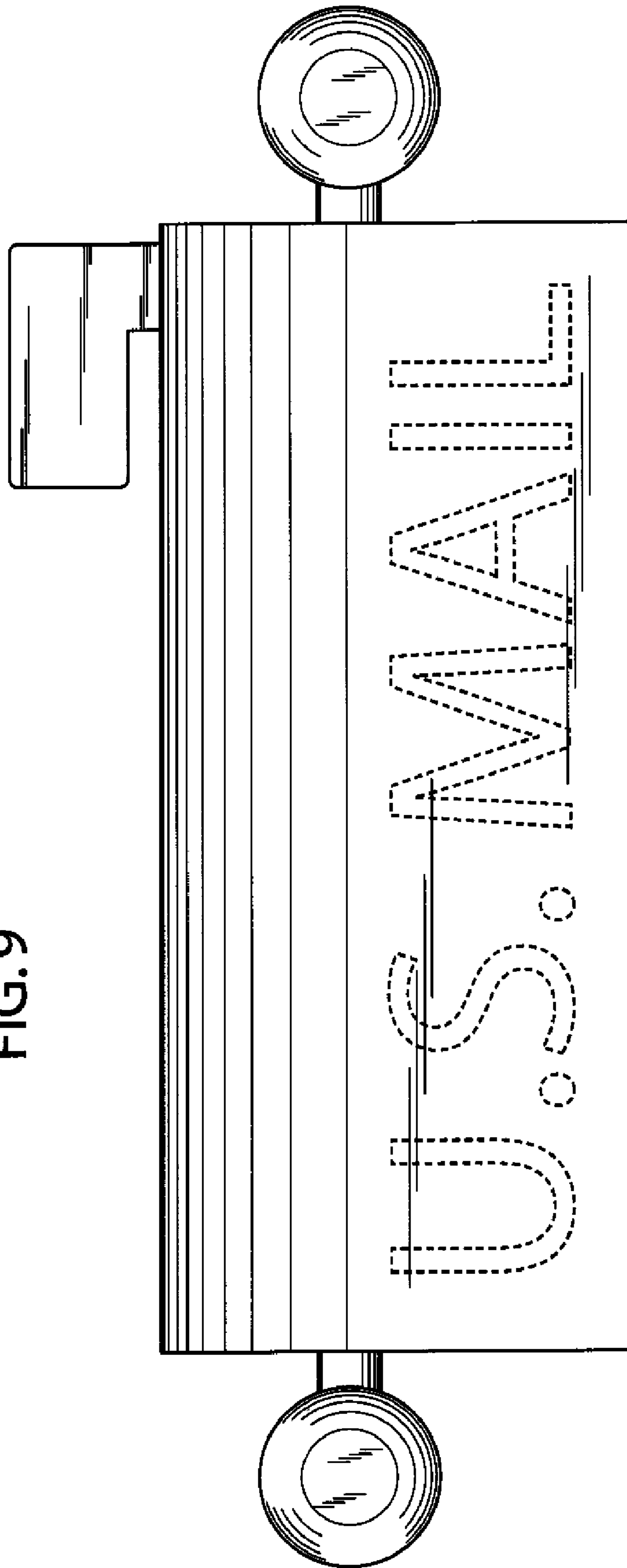

FIG. 10

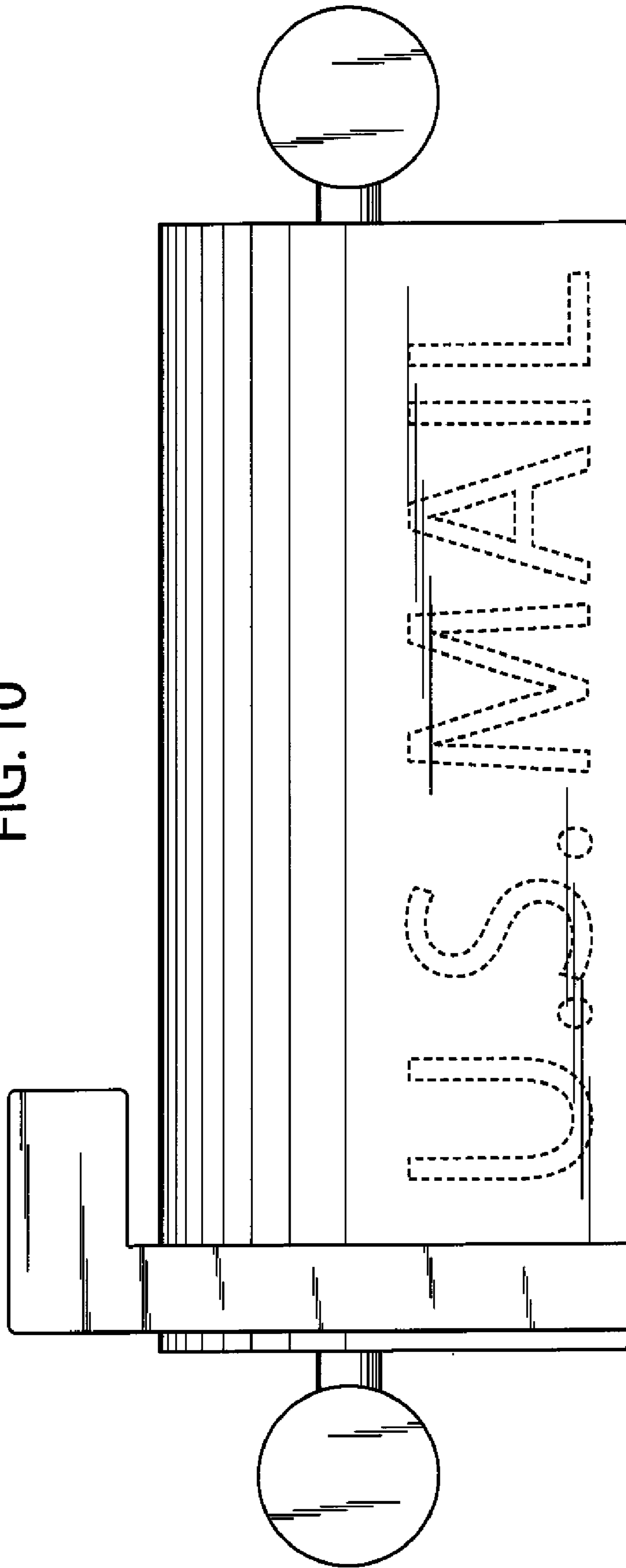

FIG. 11

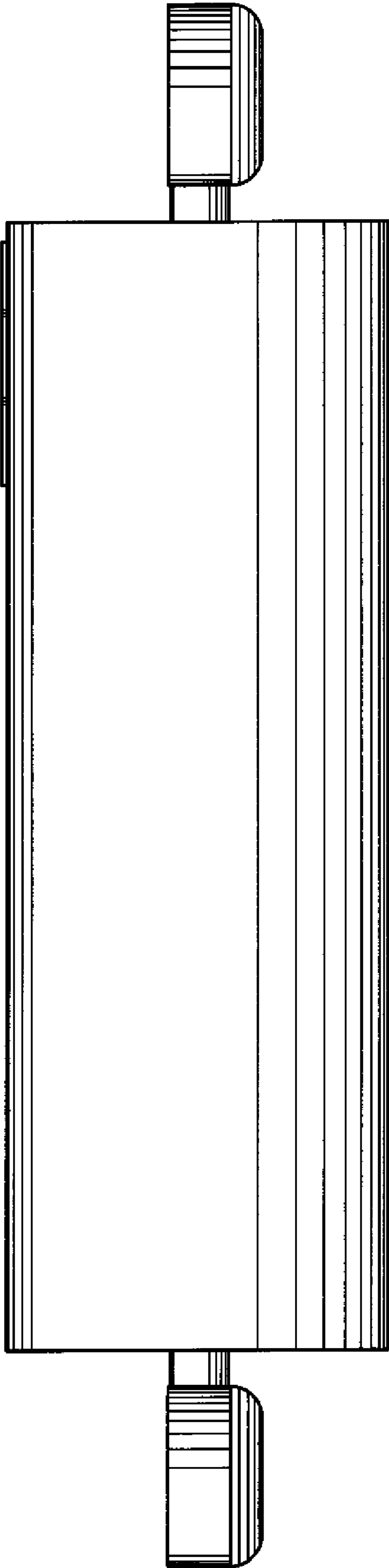
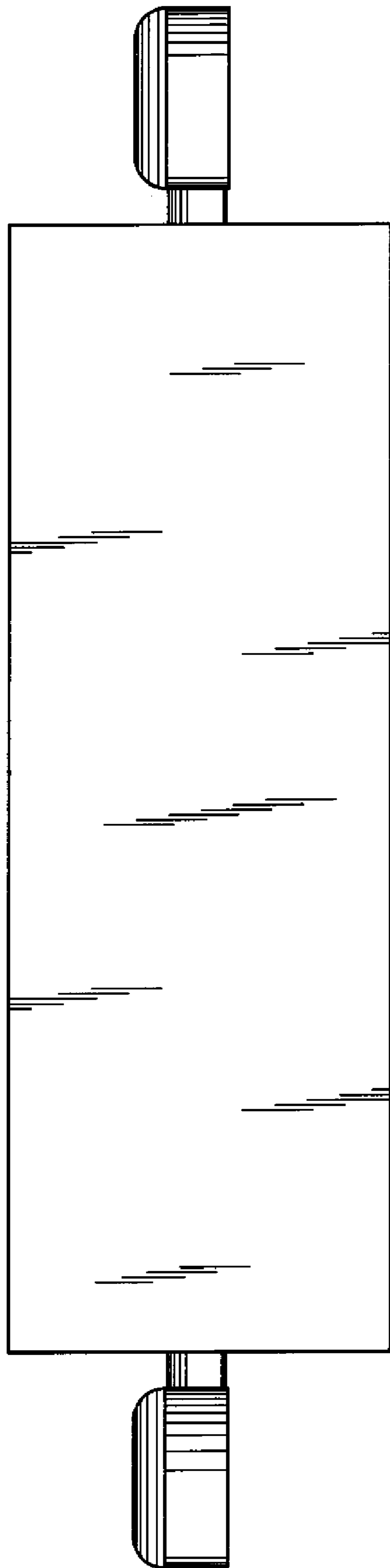

FIG. 12



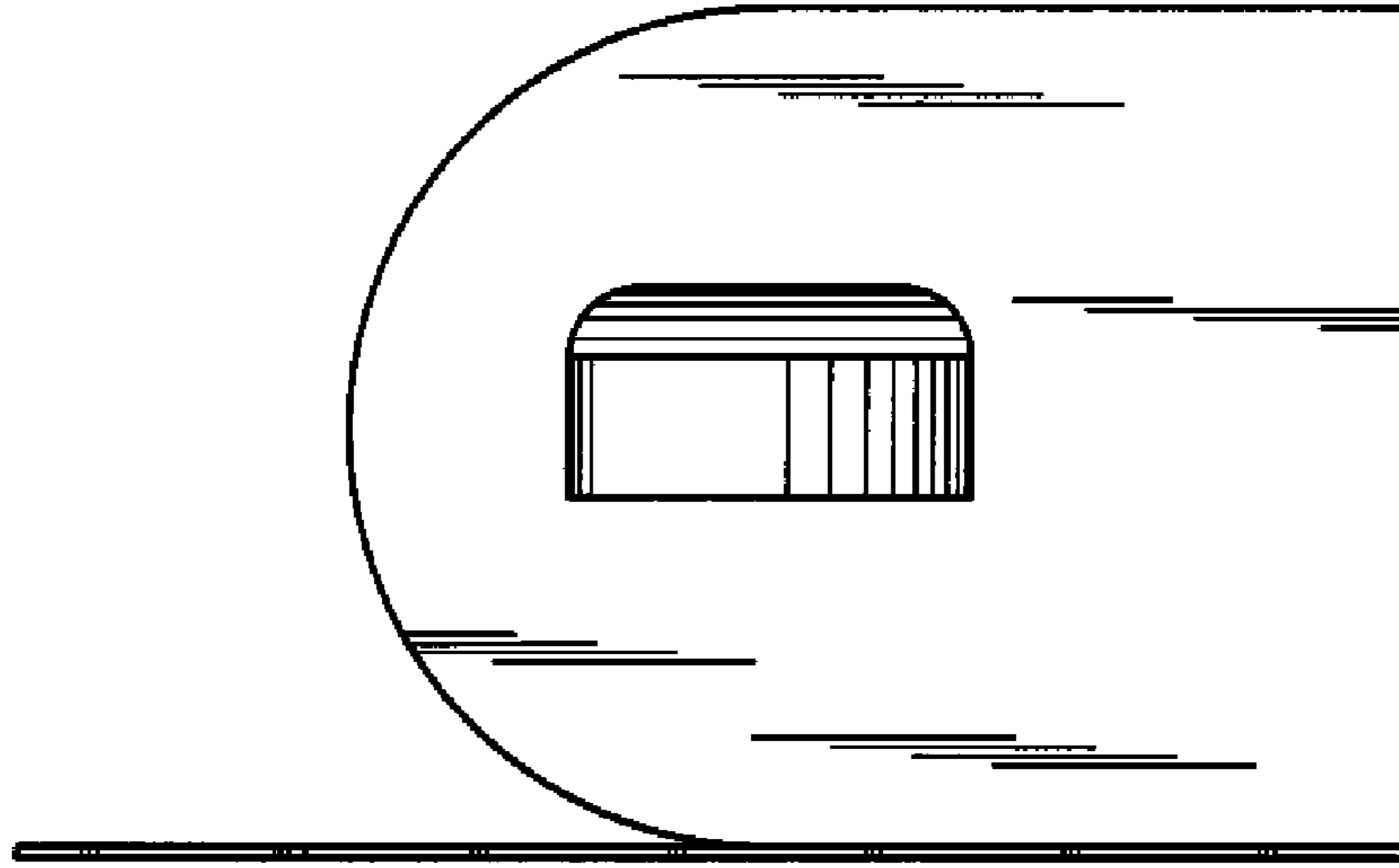

FIG. 13

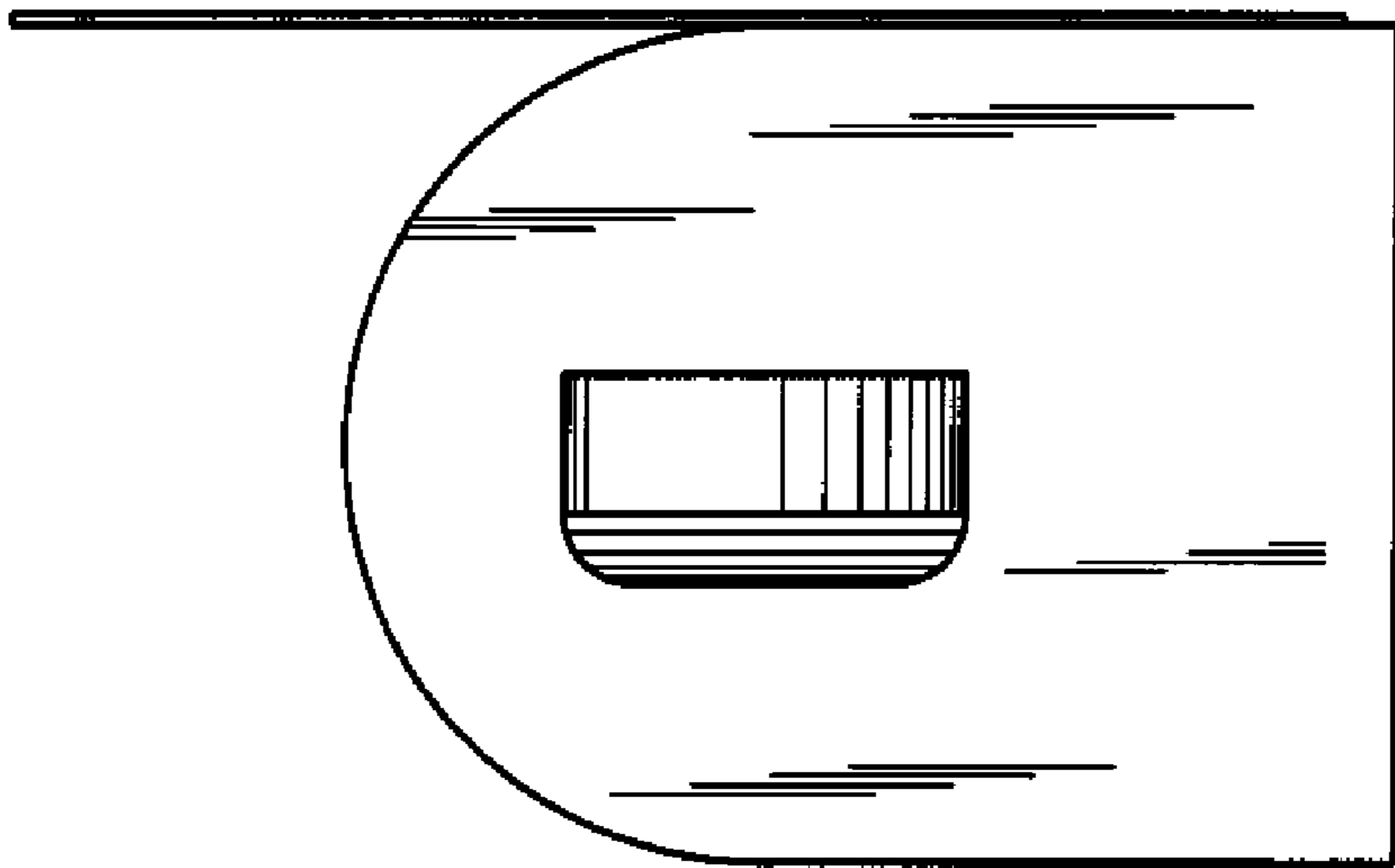

FIG. 14