



US00D572193S

(12) **United States Design Patent**
Suzuki

(10) **Patent No.:** **US D572,193 S**

(45) **Date of Patent:** **** Jul. 1, 2008**

(54) **SPARK PLUG IGNITION AID FOR VEHICLE**

(75) Inventor: **Jun Suzuki**, Tokyo (JP)

(73) Assignee: **Sun Automobile Co., Ltd.**, Tokyo (JP)

(**) Term: **14 Years**

(21) Appl. No.: **29/238,558**

(22) Filed: **Sep. 16, 2005**

(51) **LOC (8) Cl.** **13-03**

(52) **U.S. Cl.** **D13/126**

(58) **Field of Classification Search** D13/101,
D13/110, 114, 117, 123-127, 133, 154, 158,
D13/184, 199; 439/126-130, 500; 123/620;
D15/5, 149; 310/68 D; 361/18, 30, 31
See application file for complete search history.

(56) **References Cited**

U.S. PATENT DOCUMENTS

D205,844	S *	9/1966	Van Houten	D13/126
3,939,814	A *	2/1976	Bergstresser	123/620
5,355,273	A *	10/1994	Yoshizawa et al.	361/93.8
5,635,841	A *	6/1997	Taylor	324/380
D543,503	S *	5/2007	Suzuki	D13/110
D549,172	S *	8/2007	Suzuki	D13/110
2002/0185108	A1 *	12/2002	Fewell, Jr.	123/406.56
2003/0213293	A1 *	11/2003	Lee et al.	73/118.1

2006/0097704 A1* 5/2006 Deverall et al. 323/201
2007/0235304 A1* 10/2007 Chen 200/293

* cited by examiner

Primary Examiner—Daniel D Bui

Assistant Examiner—Thomas J Johannes

(74) *Attorney, Agent, or Firm*—Townsend & Banta

(57) **CLAIM**

The ornamental design for a spark plug ignition aid for vehicle, as shown and described.

DESCRIPTION

FIG. 1 is a top plan view of my spark plug ignition aid for vehicle showing my new design.

FIG. 2 is a bottom plan view thereof;

FIG. 3 is a right side view thereof;

FIG. 4 is a left side view thereof;

FIG. 5 is a front view thereof;

FIG. 6 is a rear view thereof; and,

FIG. 7 is a perspective view thereof.

The broken line showing the in the figure drawings is included for illustrative purposes only and forms no part of the claimed design.

1 Claim, 6 Drawing Sheets

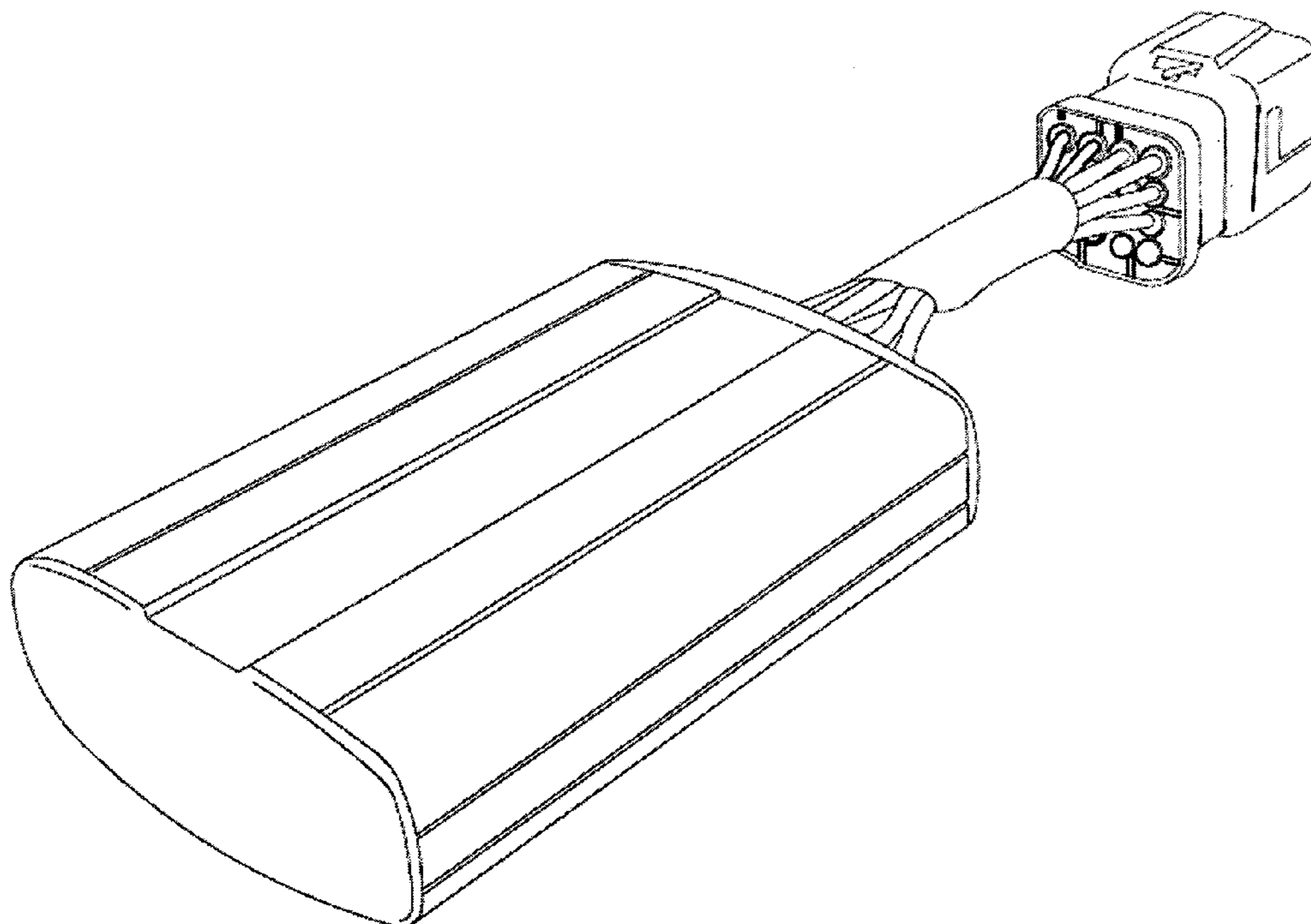

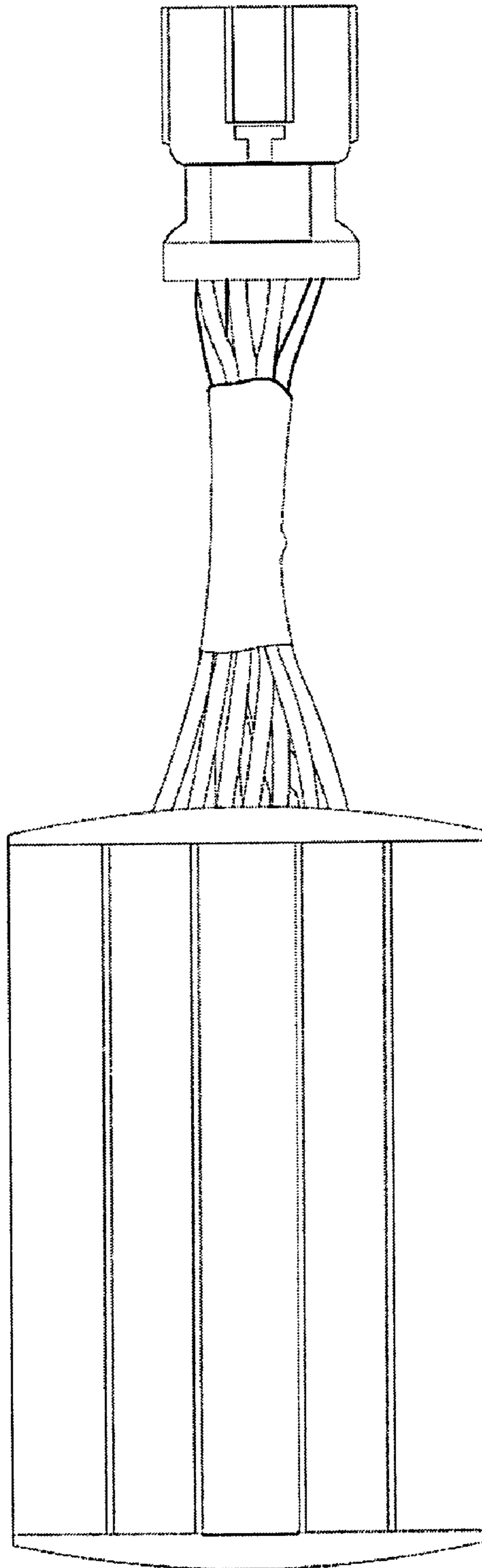

FIG. 1

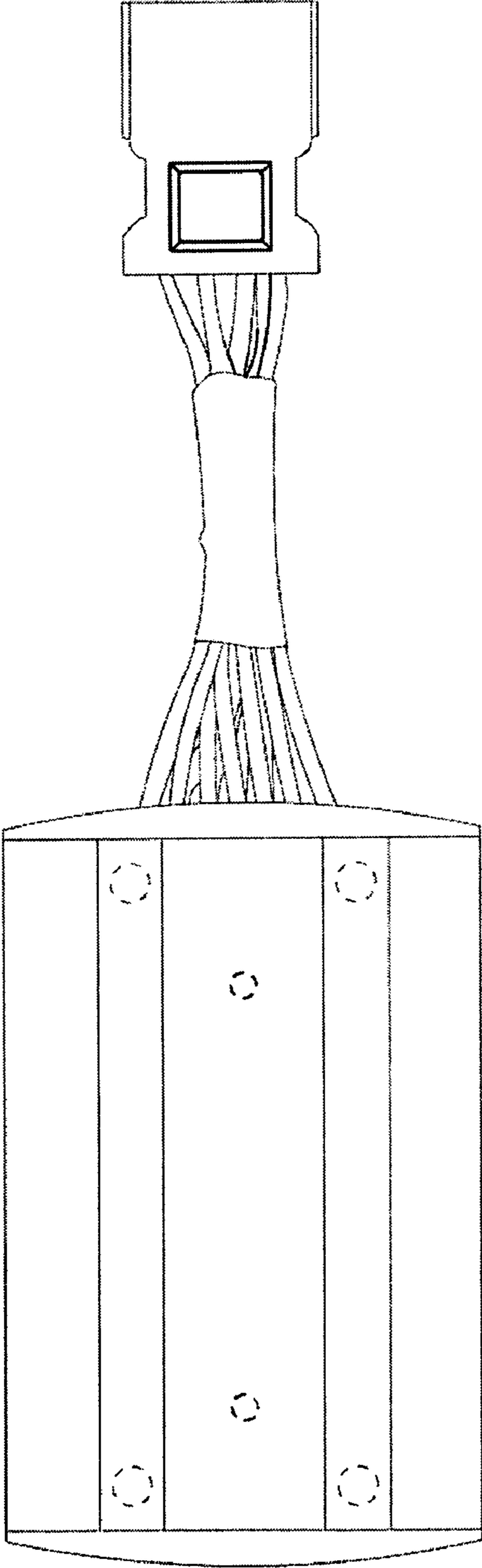

FIG. 2

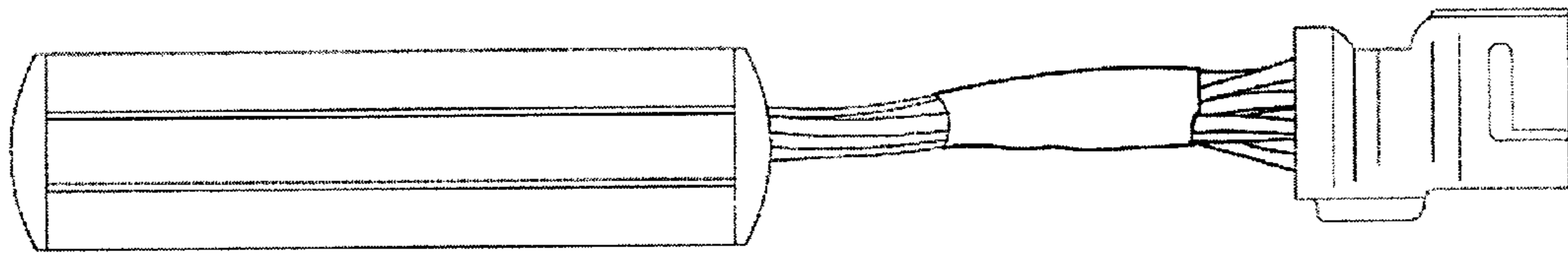

FIG. 3

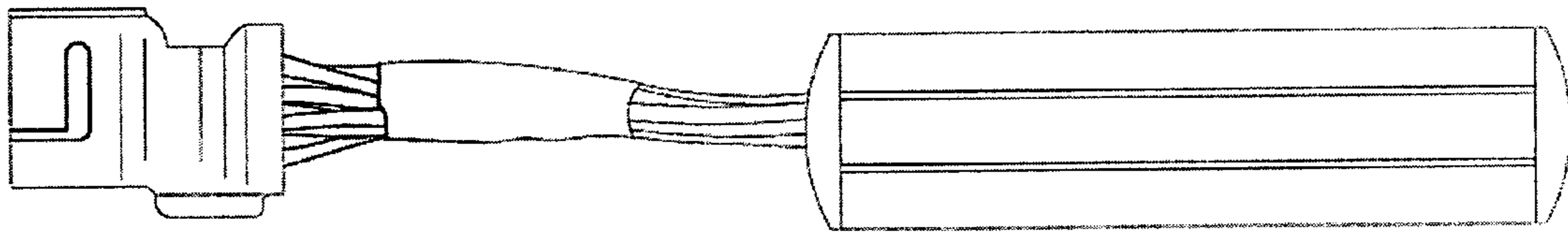

FIG. 4

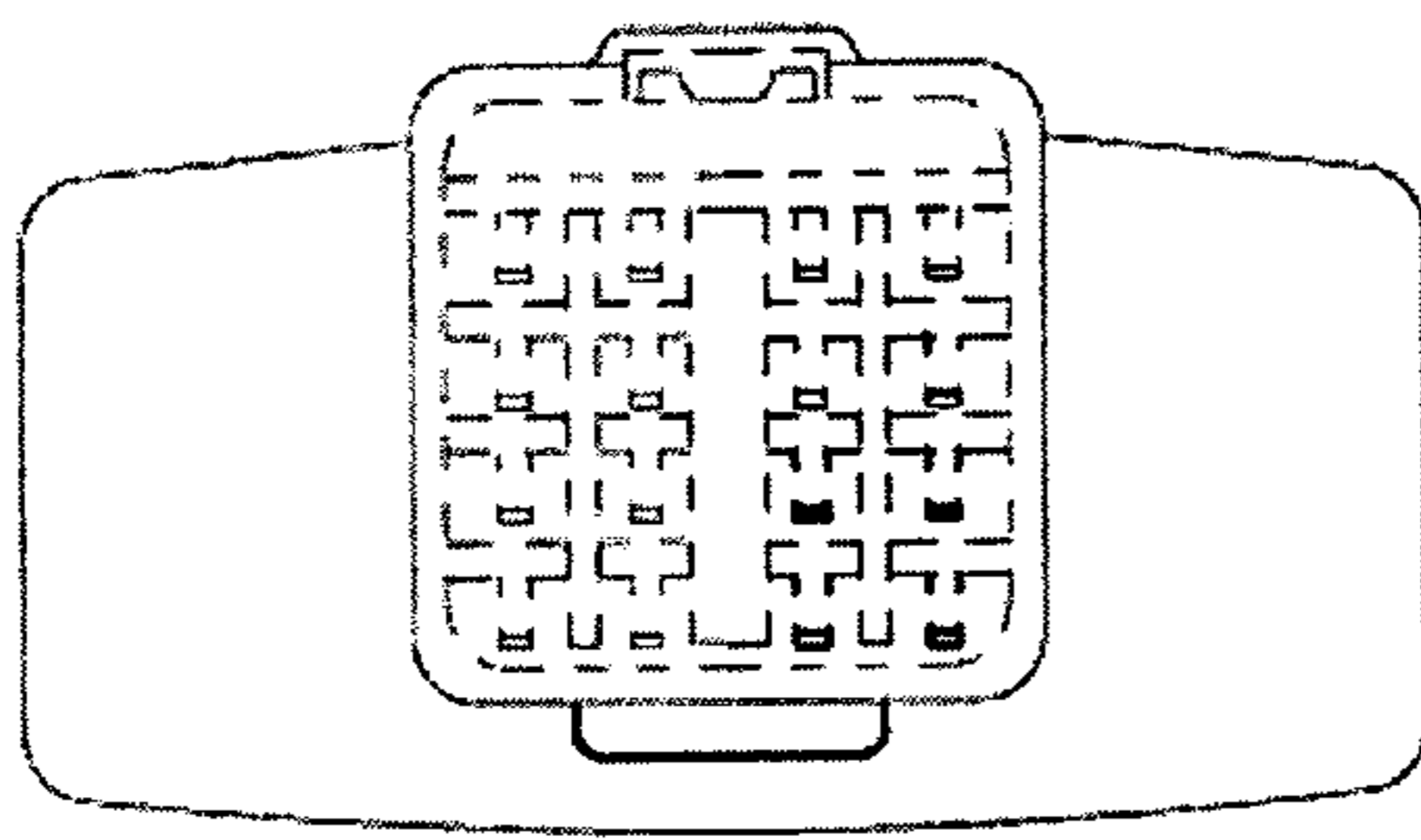

FIG. 5

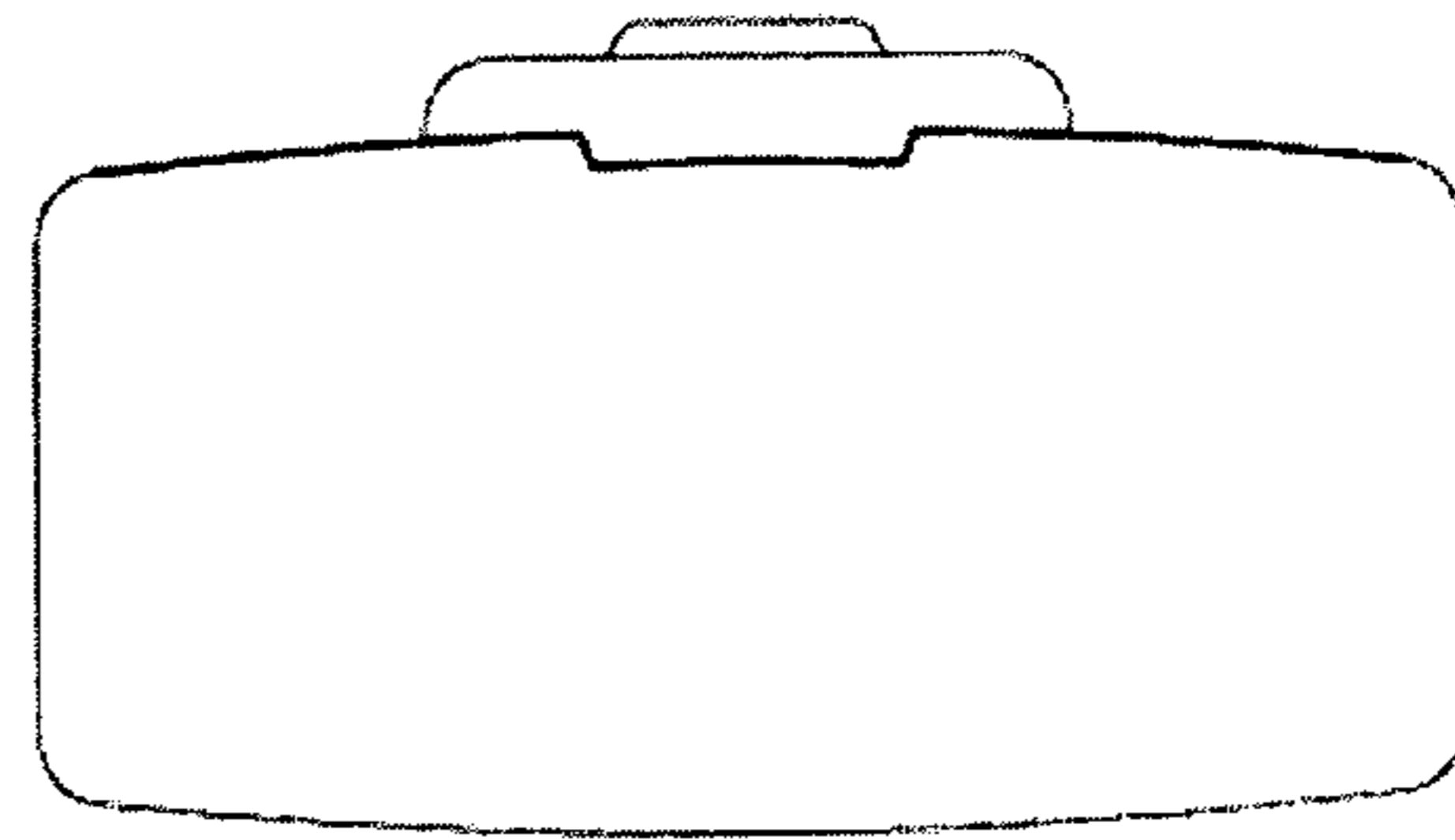

FIG. 6

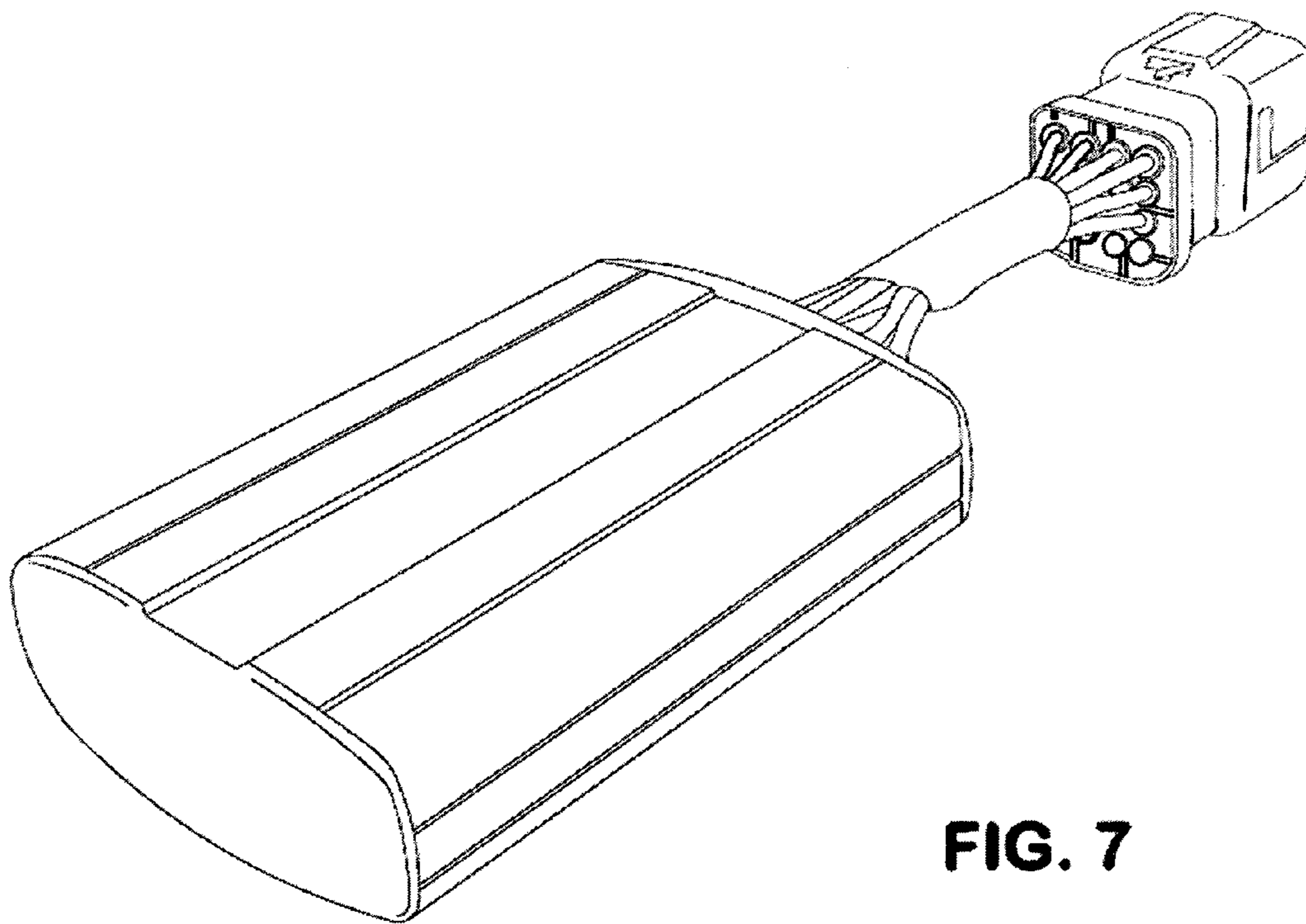

FIG. 7