



US00D572116S

(12) **United States Design Patent**
Schaefer

(10) **Patent No.:** **US D572,116 S**
(45) **Date of Patent:** **** Jul. 1, 2008**

(54) **MICROPHONE CLAMP PLATE**
(75) Inventor: **Michael Schaefer**, Vienna (AT)
(73) Assignee: **Harman International Industries, Incorporated**, Northridge, CA (US)
(**) Term: **14 Years**
(21) Appl. No.: **29/281,742**
(22) Filed: **Jun. 29, 2007**

Primary Examiner—Holly H Baynham
(74) *Attorney, Agent, or Firm*—Plumsea Law Group, LLC

(57) **CLAIM**

The ornamental design for a microphone clamp plate, as shown and described.

DESCRIPTION

(30) **Foreign Application Priority Data**
Jan. 12, 2007 (EM) 000650320
(51) **LOC (8) Cl.** **08-05**
(52) **U.S. Cl.** **D8/354; D14/229**
(58) **Field of Classification Search** D14/229,
D14/228; D8/354; 248/122.1, 638
See application file for complete search history.

FIG. 1 is a perspective view of a microphone clamp plate showing my new design;
FIG. 2 is a top plan view thereof;
FIG. 3 is a side elevational view of one side thereof;
FIG. 4 is a side elevational view of the opposite side thereof;
FIG. 5 is a rear elevational view thereof; and,
FIG. 6 is a front elevational view thereof.

(56) **References Cited**
U.S. PATENT DOCUMENTS
6,386,377 B1 * 5/2002 Yeoman 211/60.1
* cited by examiner

The broken line showings of the bottom boundary, and the left boundary of the cylindrical portion are for illustrative purposes only and form no part of the claimed design.

1 Claim, 2 Drawing Sheets

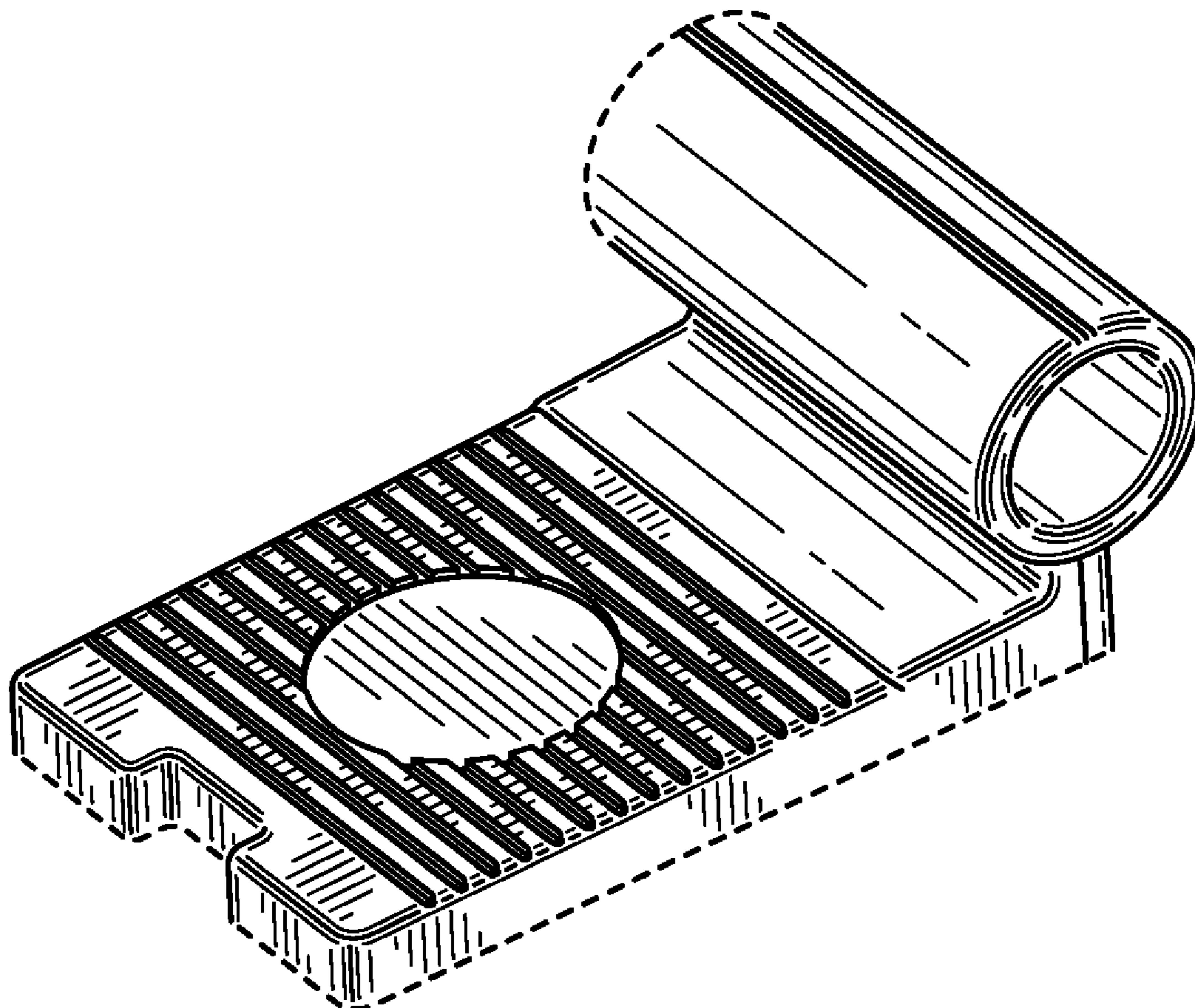

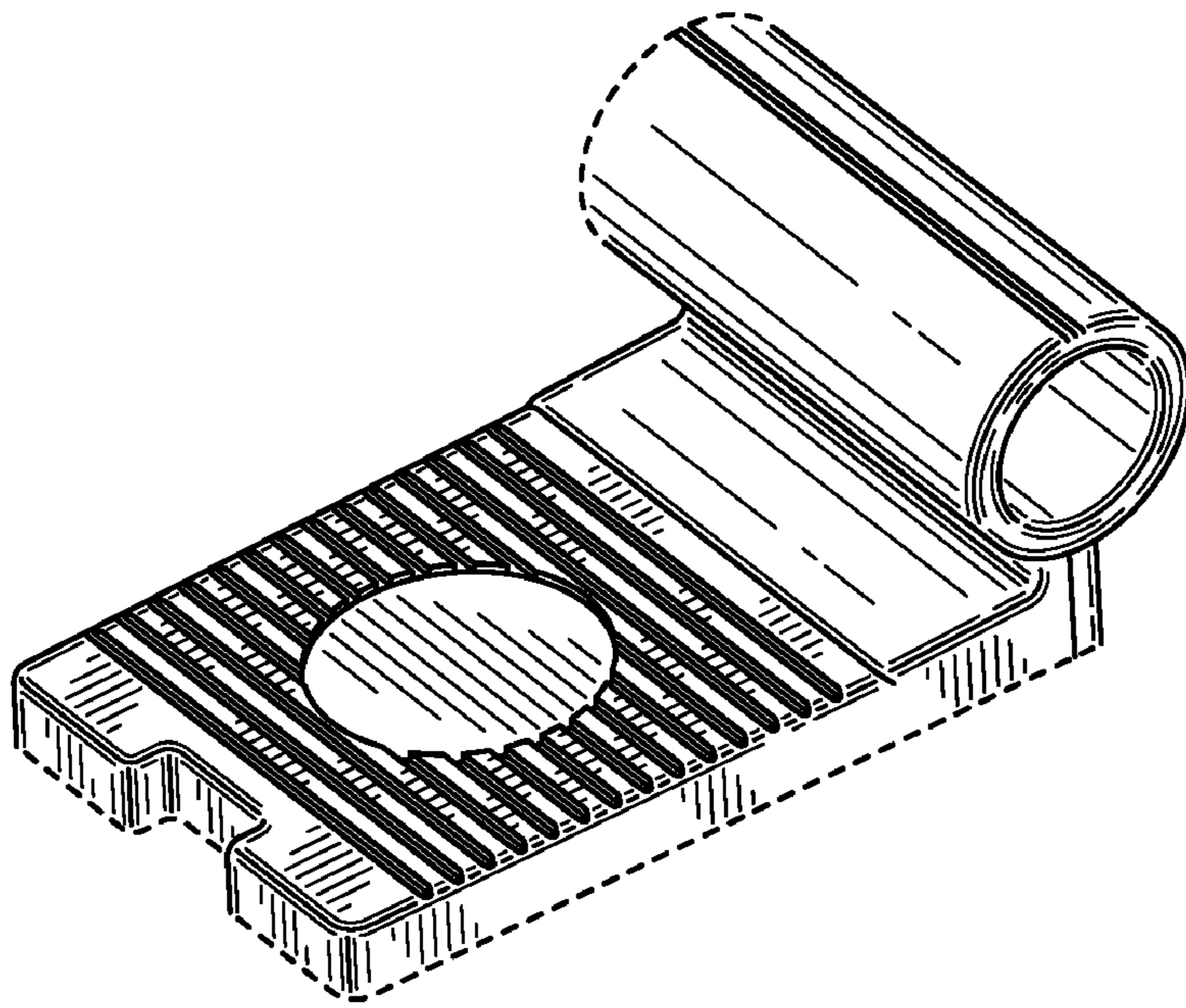

FIG. 1

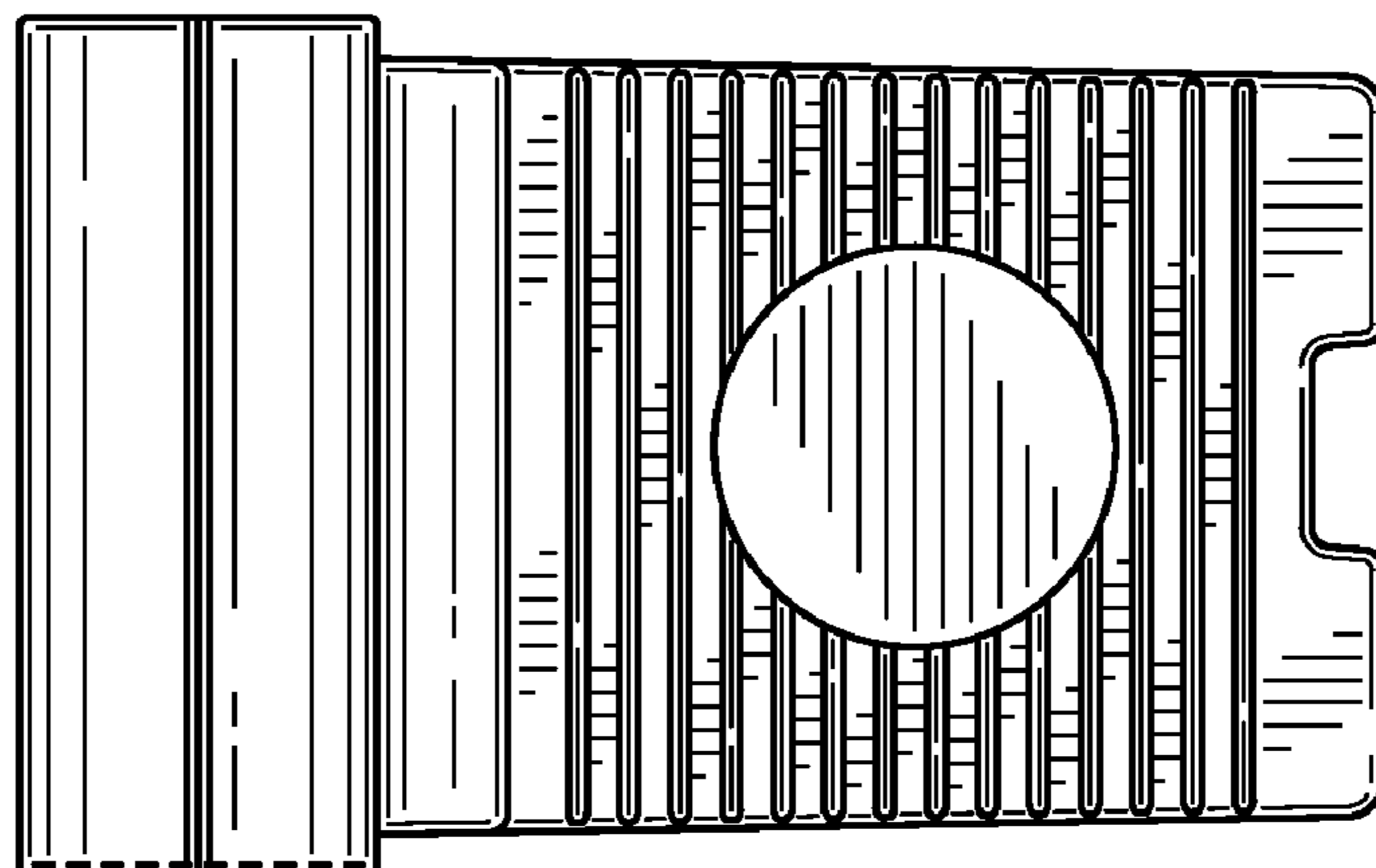

FIG. 2

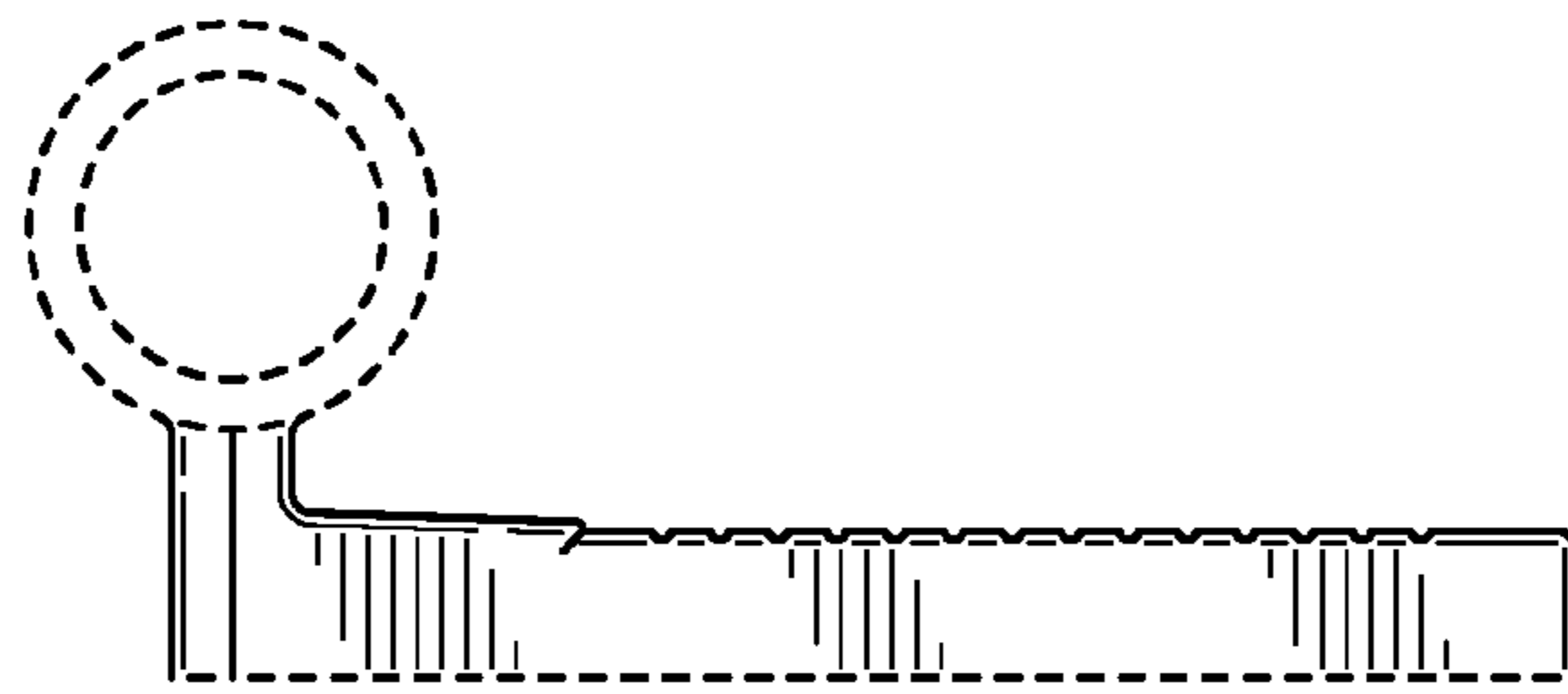

FIG. 3



FIG. 4

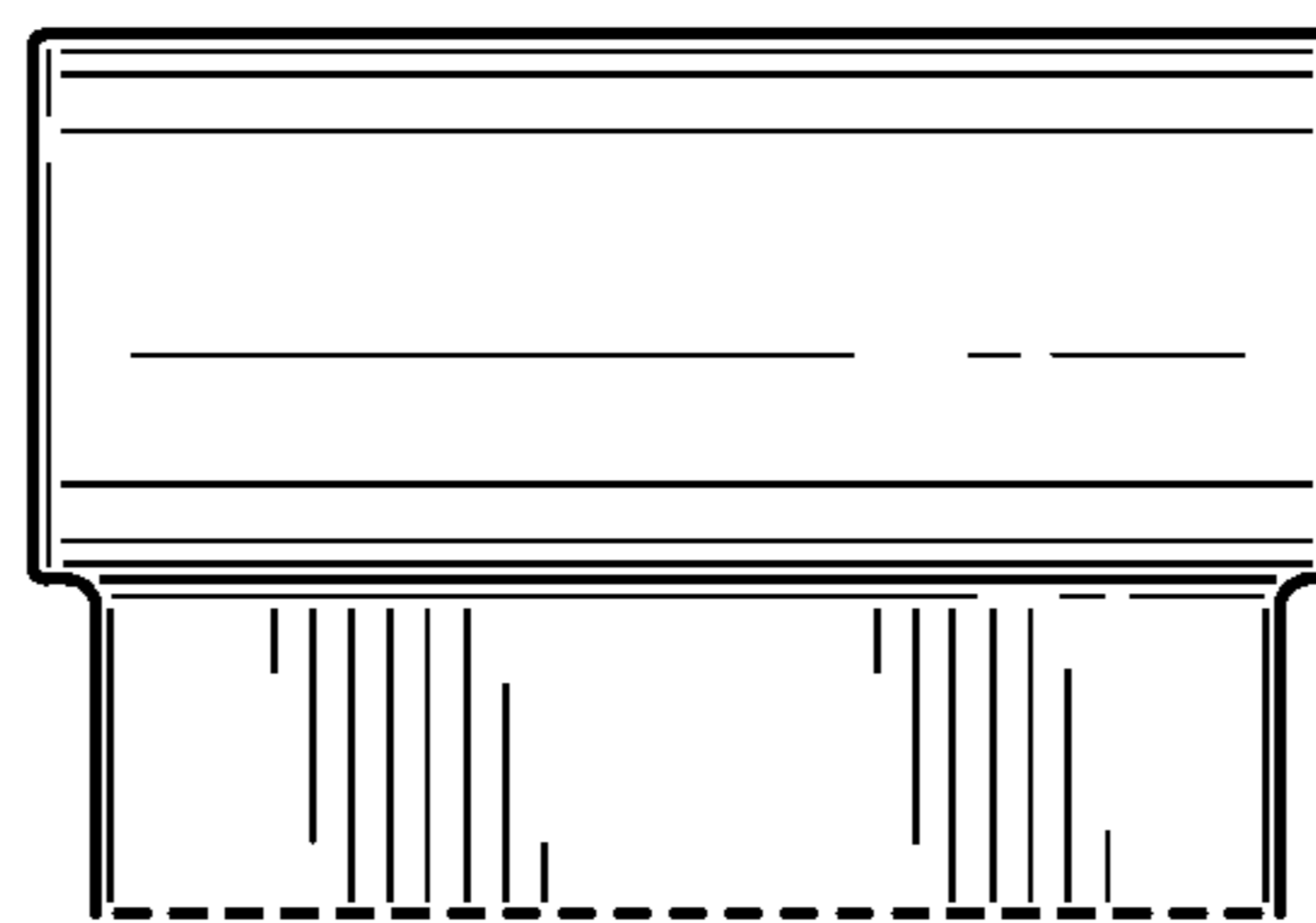

FIG. 5

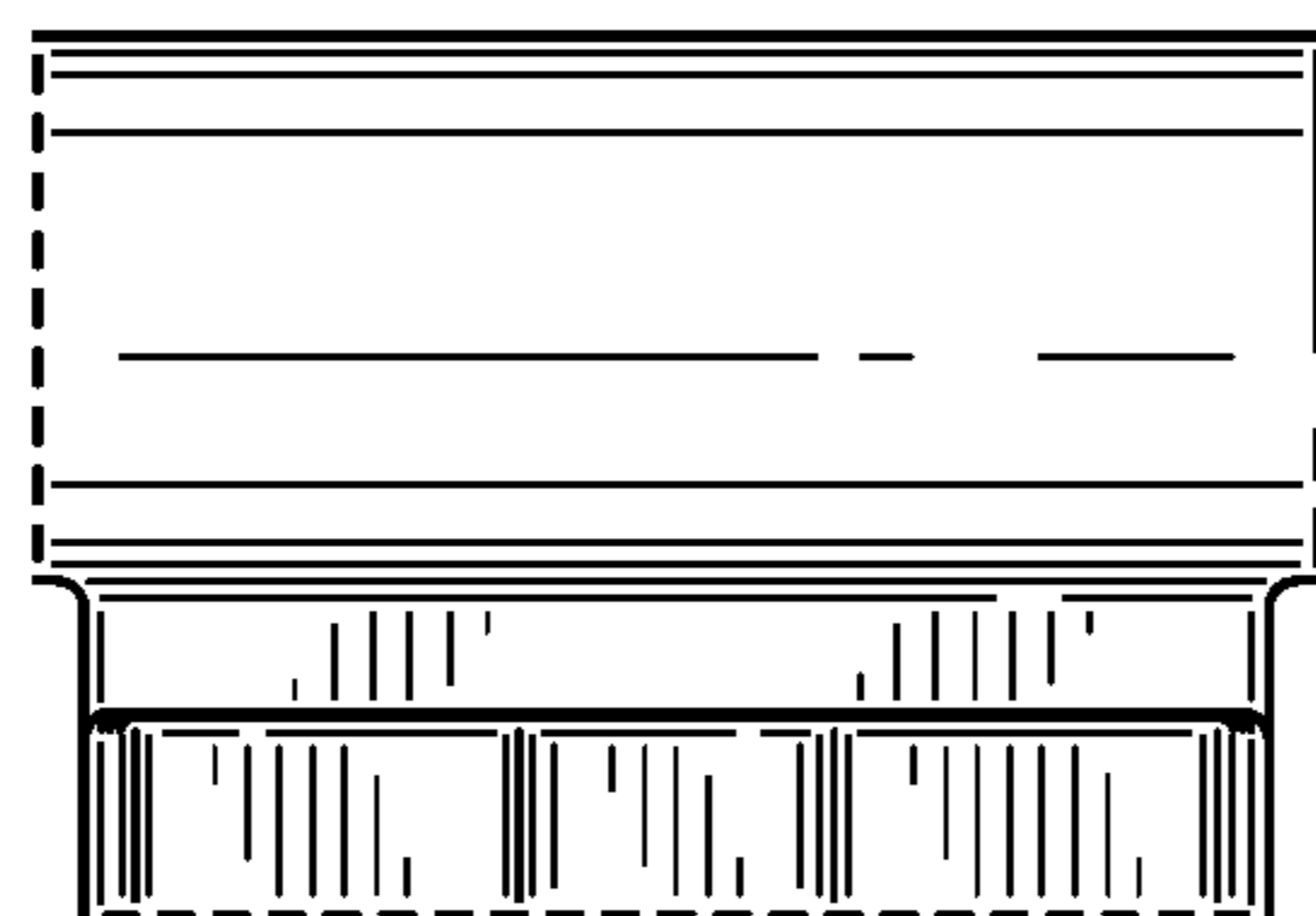

FIG. 6