



US00D571837S

(12) **United States Design Patent**  
**Lannoch**

(10) **Patent No.:** **US D571,837 S**  
(45) **Date of Patent:** **\*\* Jun. 24, 2008**

(54) **GEAR UNIT**

(75) Inventor: **Hans-Juergen Lannoch,**  
Linkenheim-Hochstetten (DE)

(73) Assignee: **Sew-Eurodrive GmbH & Co. KG** (DE)

(\*\*) Term: **14 Years**

(21) Appl. No.: **29/240,862**

(22) Filed: **Oct. 18, 2005**

(30) **Foreign Application Priority Data**

Apr. 18, 2005 (DE) ..... 4 05 02 125

(51) **LOC (8) Cl.** ..... **15-09**

(52) **U.S. Cl.** ..... **D15/148**

(58) **Field of Classification Search** ..... D15/148,  
D15/149; 74/395, 411, 640; 475/83, 331-335,  
475/345

See application file for complete search history.

(56) **References Cited**

**U.S. PATENT DOCUMENTS**

D277,487 S *	2/1985	Nilsson	.....	D15/149
D406,596 S *	3/1999	Ziegler et al.	.....	D15/148
5,950,502 A *	9/1999	Genovese	.....	74/640
D419,577 S *	1/2000	Lannoch	.....	D15/148
D479,725 S *	9/2003	Lannoch	.....	D15/148
D529,059 S *	9/2006	Lin	.....	D15/148
2006/0048595 A1 *	3/2006	Obermeier	.....	74/417

\* cited by examiner

*Primary Examiner*—Antoine D. Davis

*Assistant Examiner*—Patricia Palasik

(74) *Attorney, Agent, or Firm*—Kenyon & Kenyon LLP

(57) **CLAIM**

The ornamental design for a gear unit, as shown and described.

**DESCRIPTION**

FIG. 1 is a left side view of an example embodiment of a gear unit showing my new design.

FIG. 2 is a front view thereof.

FIG. 3 is a rear view thereof.

FIG. 4 is a right side view thereof.

FIG. 5 is a top view thereof.

FIG. 6 is a bottom view thereof.

FIG. 7 is a perspective view thereof.

FIG. 8 is a left side view of an example embodiment of a gear unit showing my new design.

FIG. 9 is a front view thereof.

FIG. 10 is a rear view thereof.

FIG. 11 is a right side view thereof.

FIG. 12 is a top view thereof.

FIG. 13 is a bottom view thereof.

FIG. 14 is a perspective view thereof.

FIG. 15 is a left side view of an example embodiment of a gear unit showing my new design.

FIG. 16 is a front view thereof.

FIG. 17 is a rear view thereof.

FIG. 18 is a right side view thereof.

FIG. 19 is a top view thereof.

FIG. 20 is a bottom view thereof.

FIG. 21 is a perspective view thereof.

FIG. 22 is a left side view of an example embodiment of a gear unit showing my new design.

FIG. 23 is a front view thereof.

FIG. 24 is a rear view thereof.

FIG. 25 is a right side view thereof.

FIG. 26 is a top view thereof.

FIG. 27 is a bottom view thereof.

FIG. 28 is a perspective view thereof.

FIG. 29 is a left side view of an example embodiment of a gear unit showing my new design.

FIG. 30 is a front view thereof.

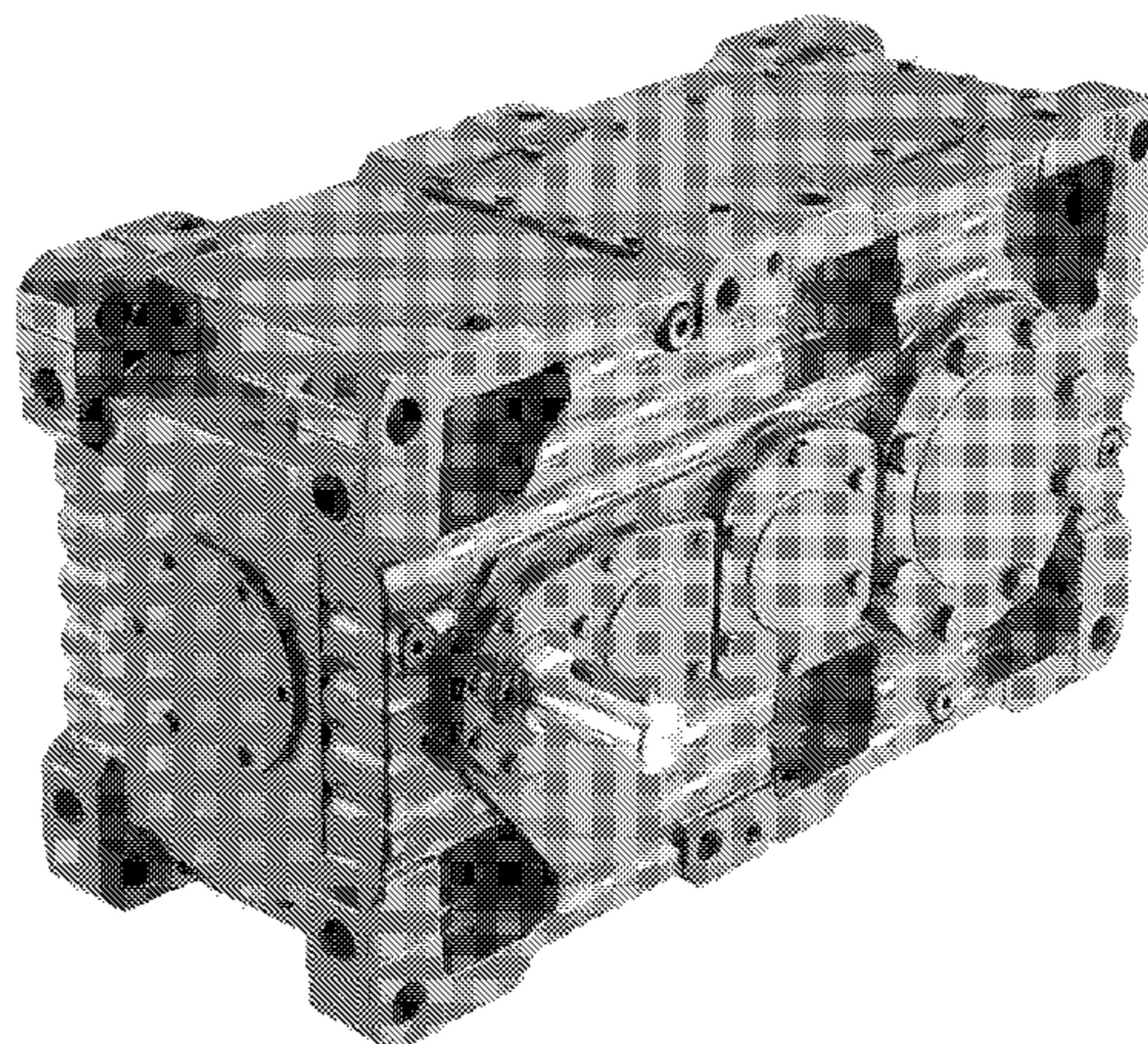

FIG. **31** is a rear view thereof.  
FIG. **32** is a right side view thereof.  
FIG. **33** is a top view thereof.  
FIG. **34** is a bottom view thereof.  
FIG. **35** is a perspective view thereof.  
FIG. **36** is a left side view of an example embodiment of a gear unit showing my new design;  
FIG. **37** is a front view thereof.  
FIG. **38** is a rear view thereof.  
FIG. **39** is a right side view thereof.  
FIG. **40** is a top view thereof.  
FIG. **41** is a bottom view thereof.  
FIG. **42** is a perspective view thereof.  
FIG. **43** is a left side view of an example embodiment of a gear unit showing my new design.  
FIG. **44** is a front view thereof.  
FIG. **45** is a rear view thereof.

FIG. **46** is a right side view thereof.  
FIG. **47** is a top view thereof.  
FIG. **48** is a bottom view thereof.  
FIG. **49** is a perspective view thereof.  
FIG. **50** is a left side view of an example embodiment of a gear unit showing my new design.  
FIG. **51** is a front view thereof.  
FIG. **52** is a rear view thereof.  
FIG. **53** is a right side view thereof.  
FIG. **54** is a top view thereof.  
FIG. **55** is a bottom view thereof; and,  
FIG. **56** is a perspective view thereof.  
The gear unit hereof may be arranged as a heavy industrial gear unit, e.g., a large-reduction gear unit for heavy industrial applications.

**1 Claim, 56 Drawing Sheets**

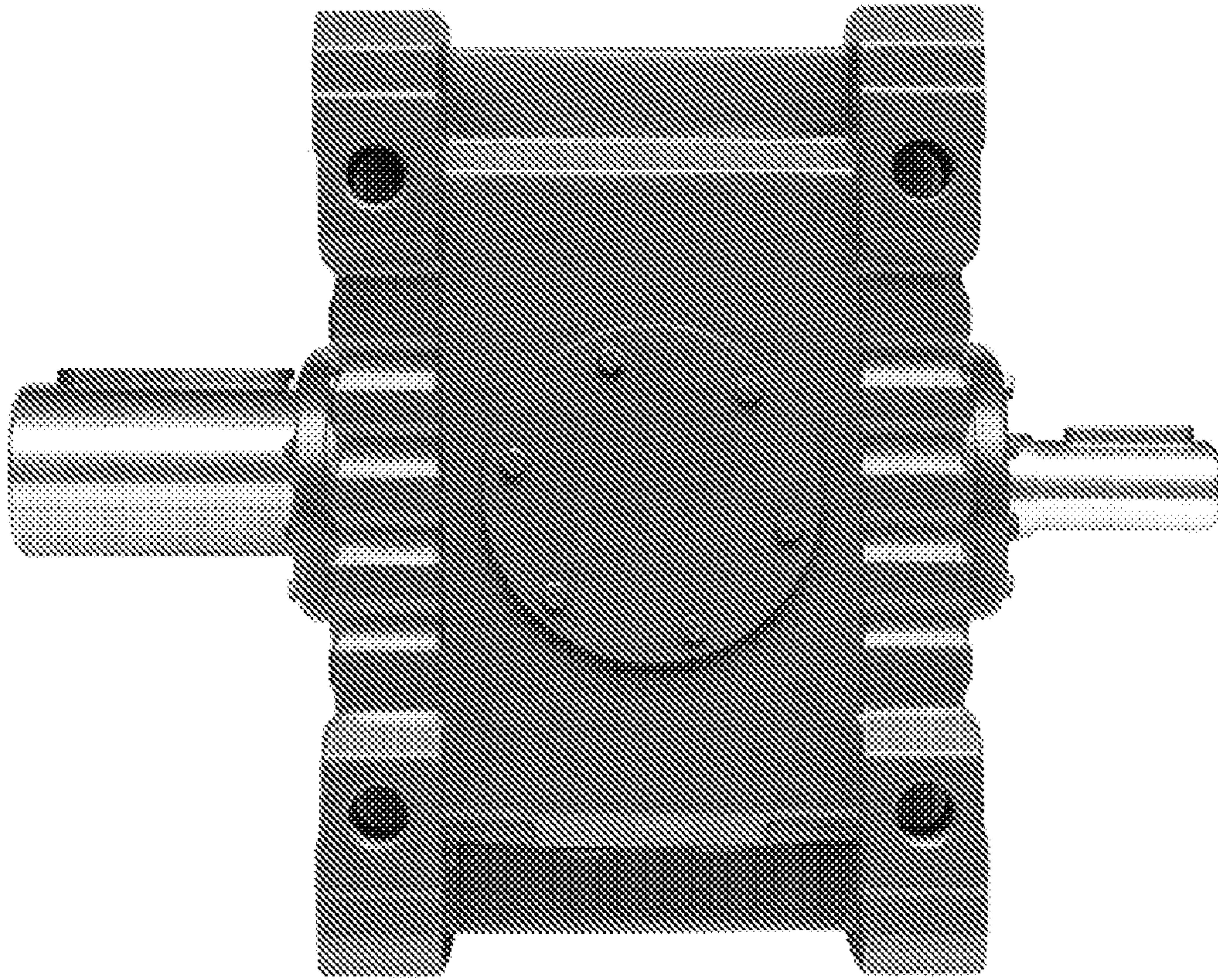

Fig. 1

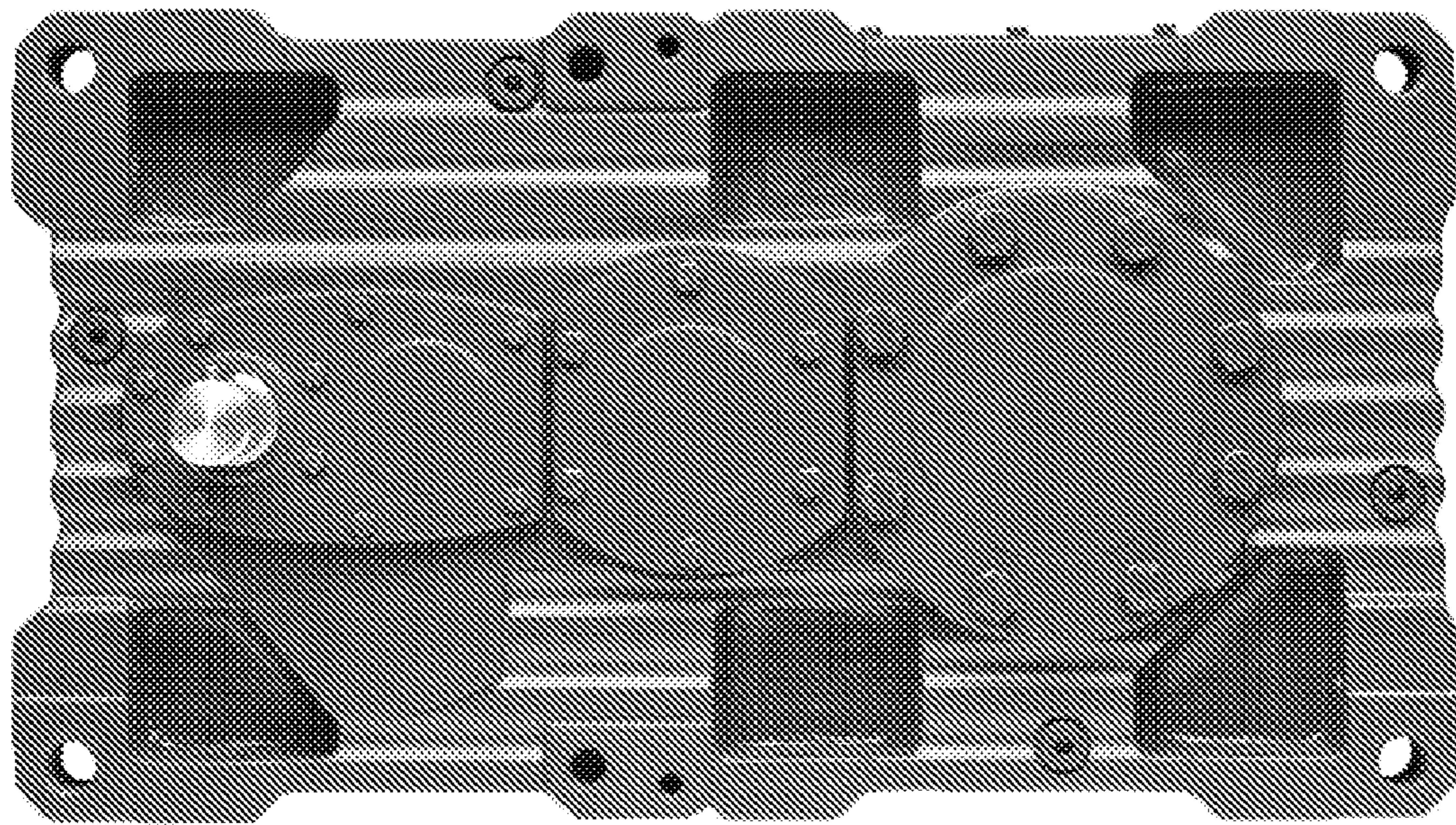

Fig. 2

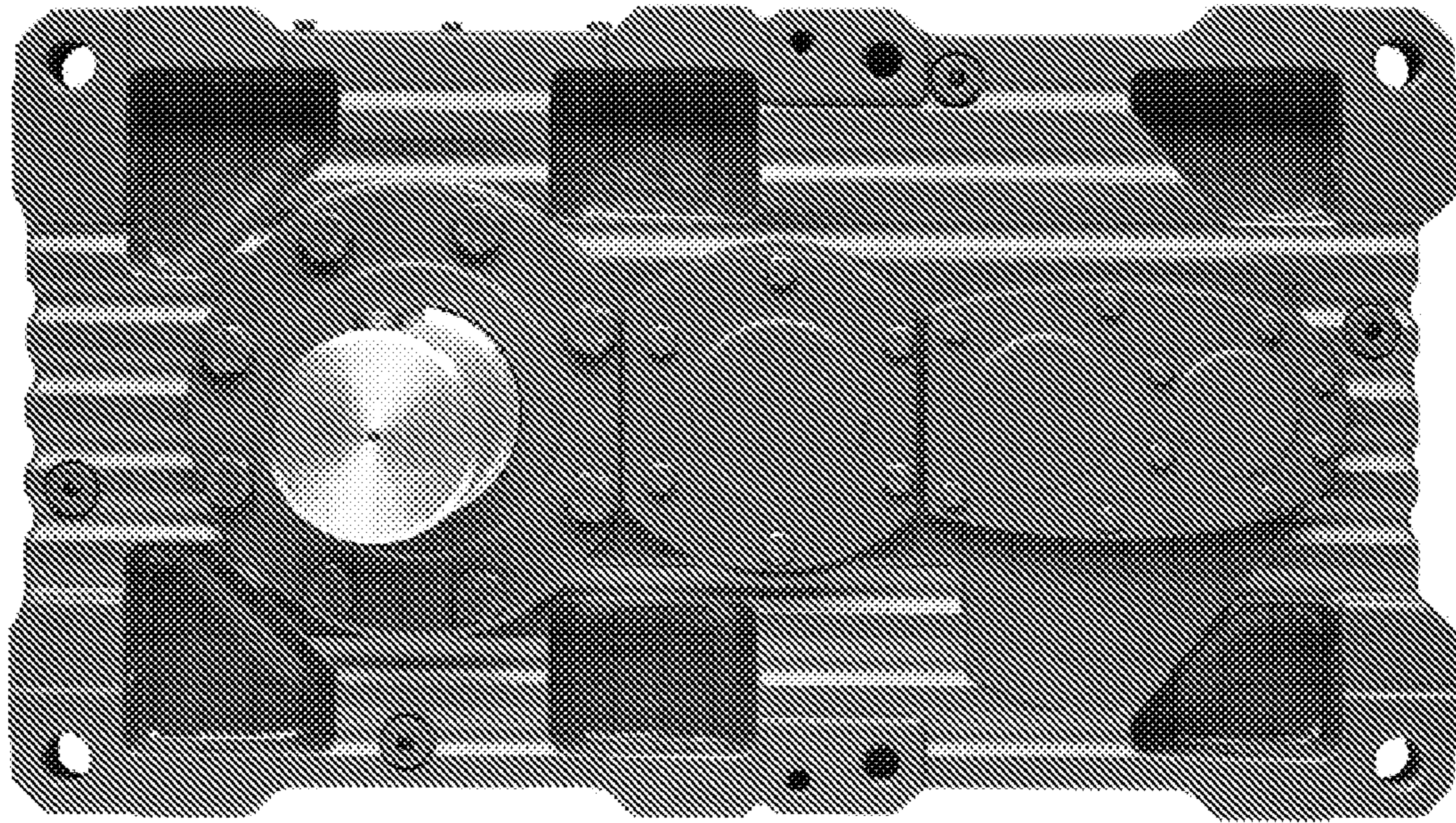

Fig. 3

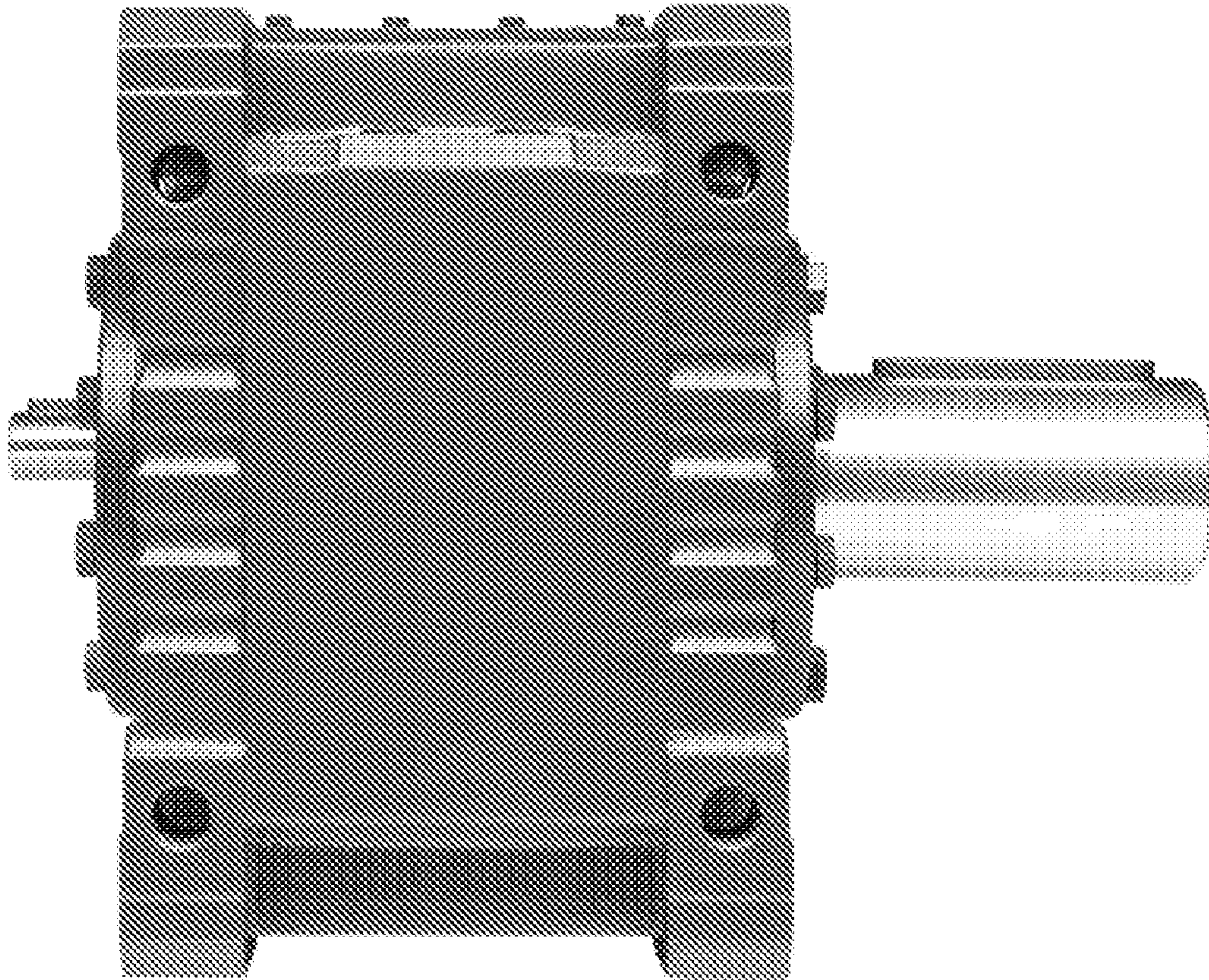

Fig. 4

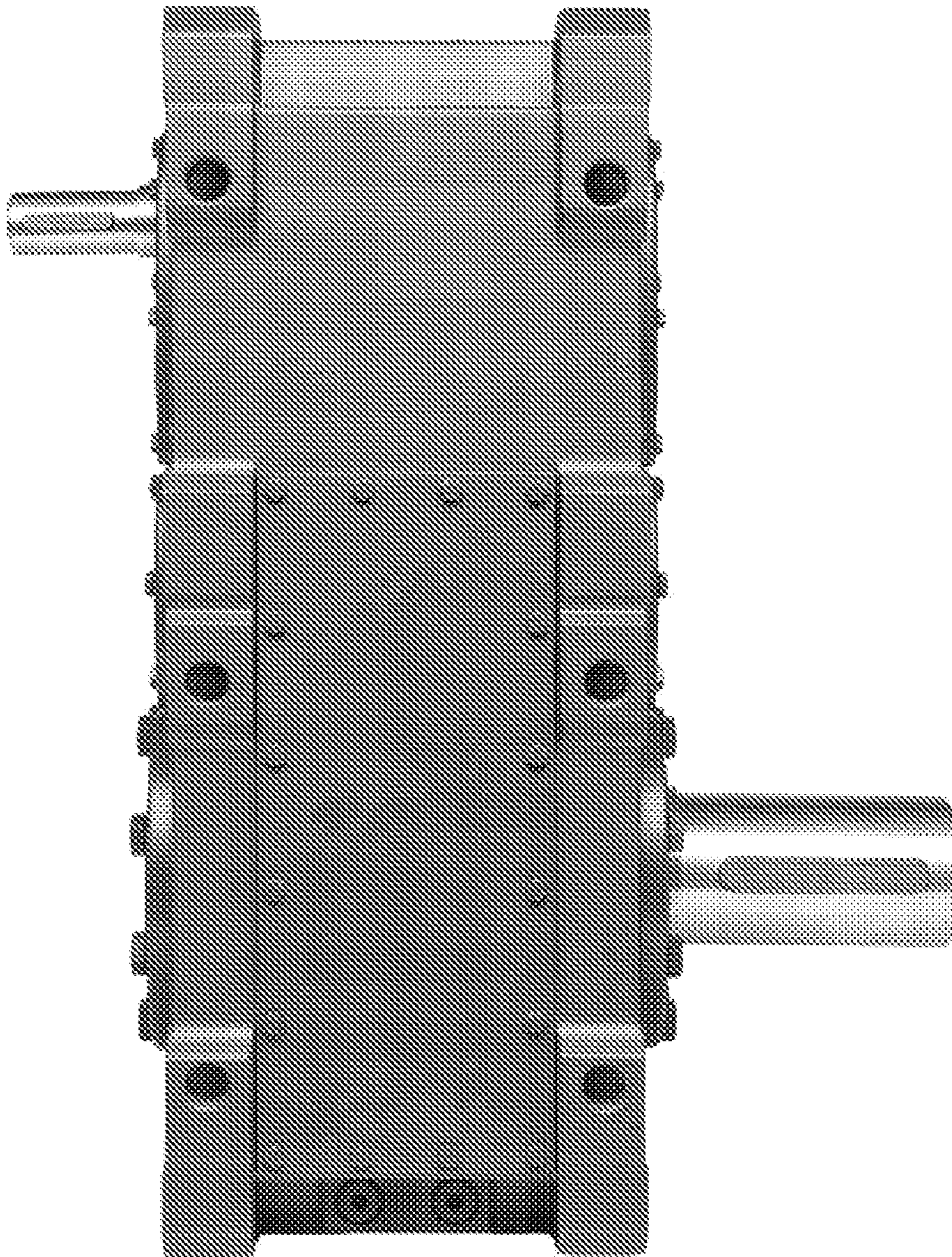

Fig. 5

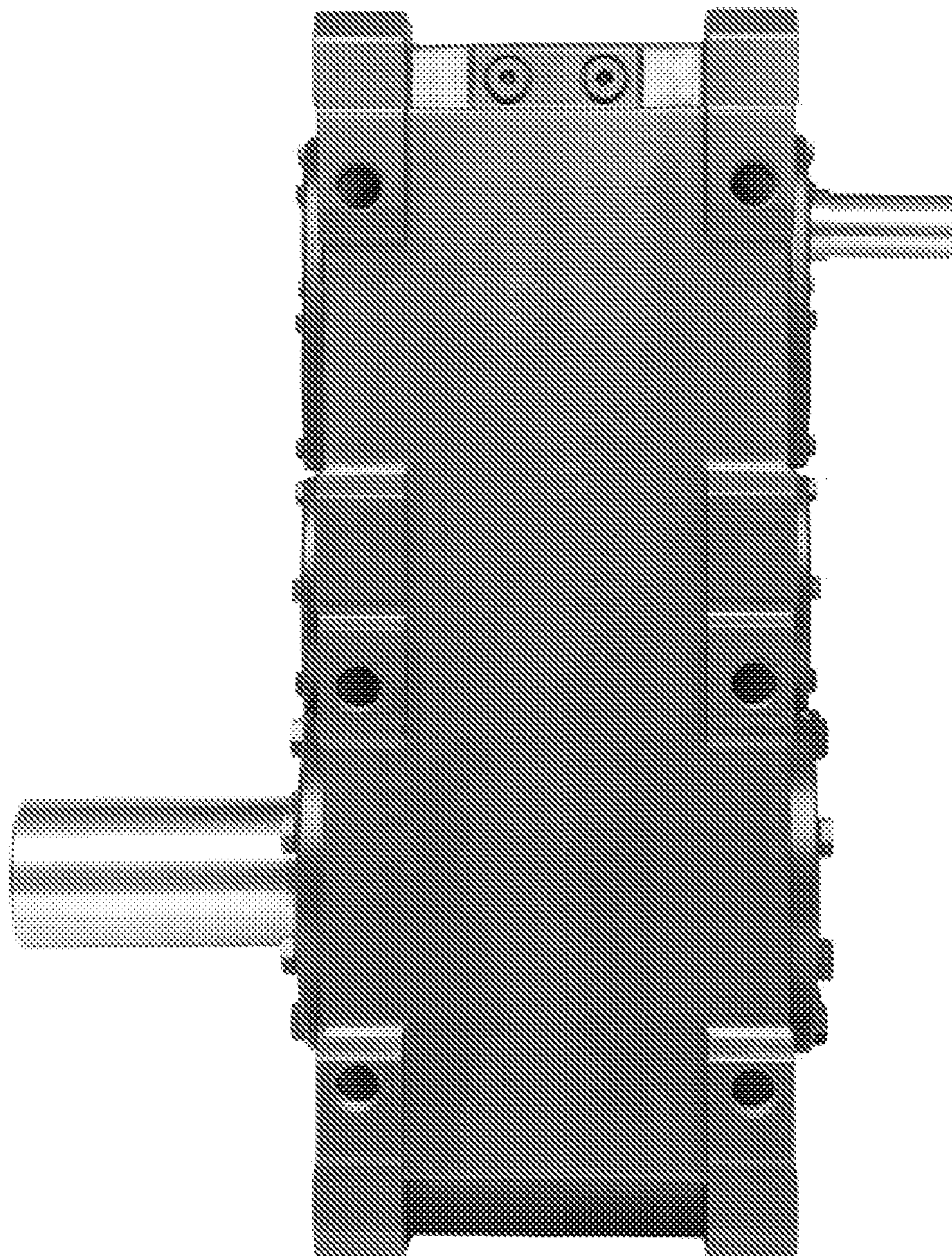

Fig. 6



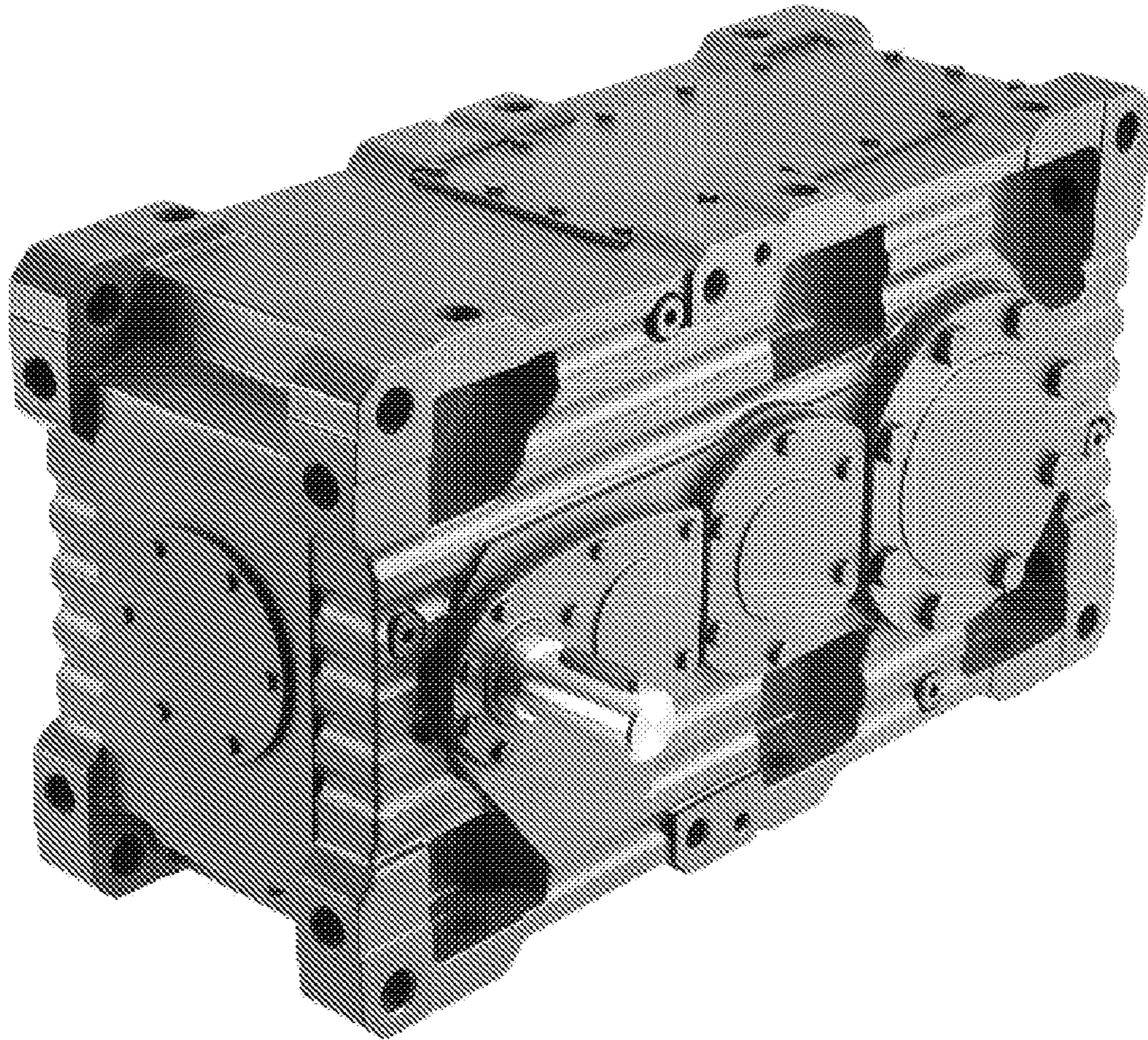

Fig. 7

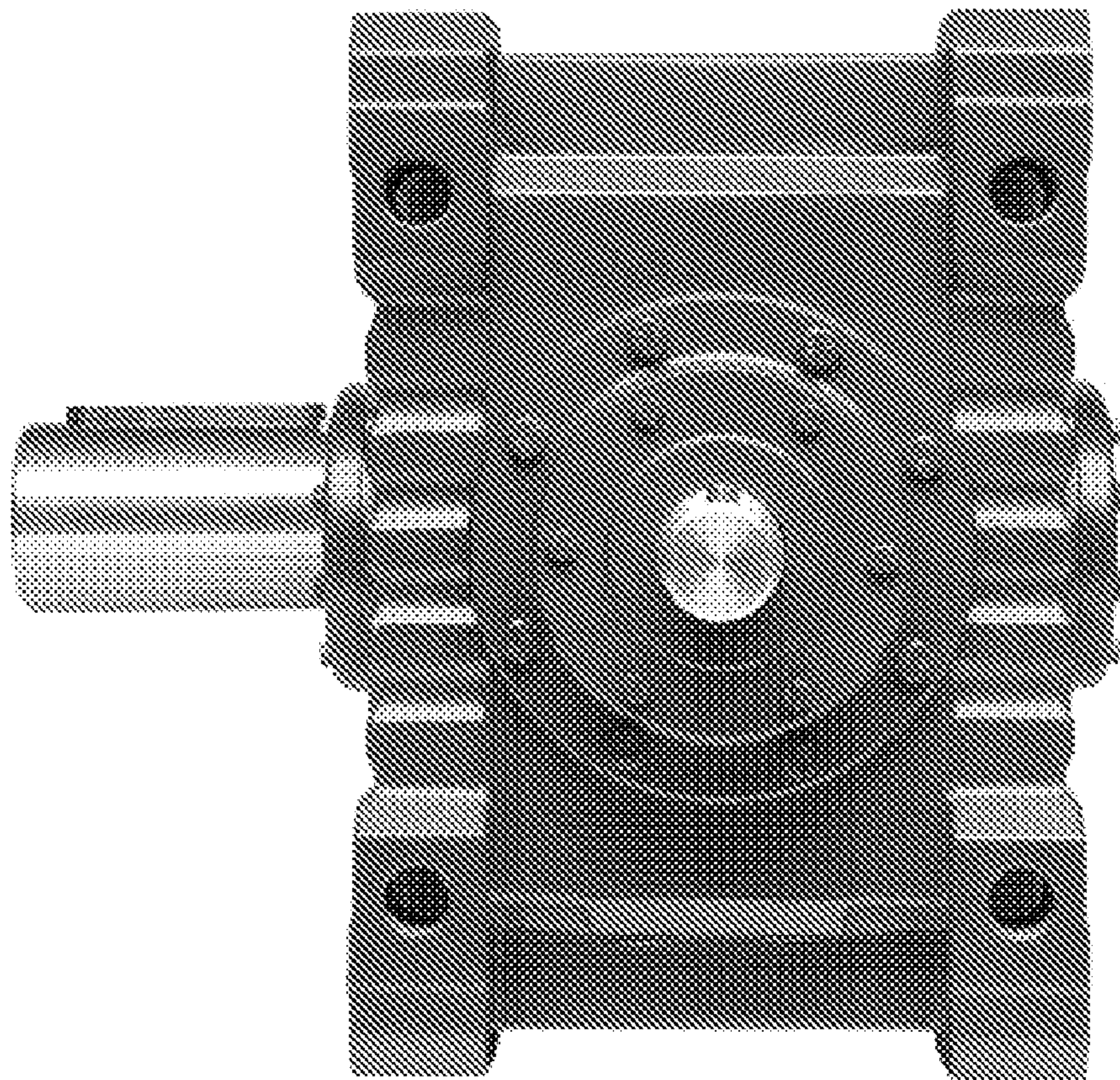

Fig. 8

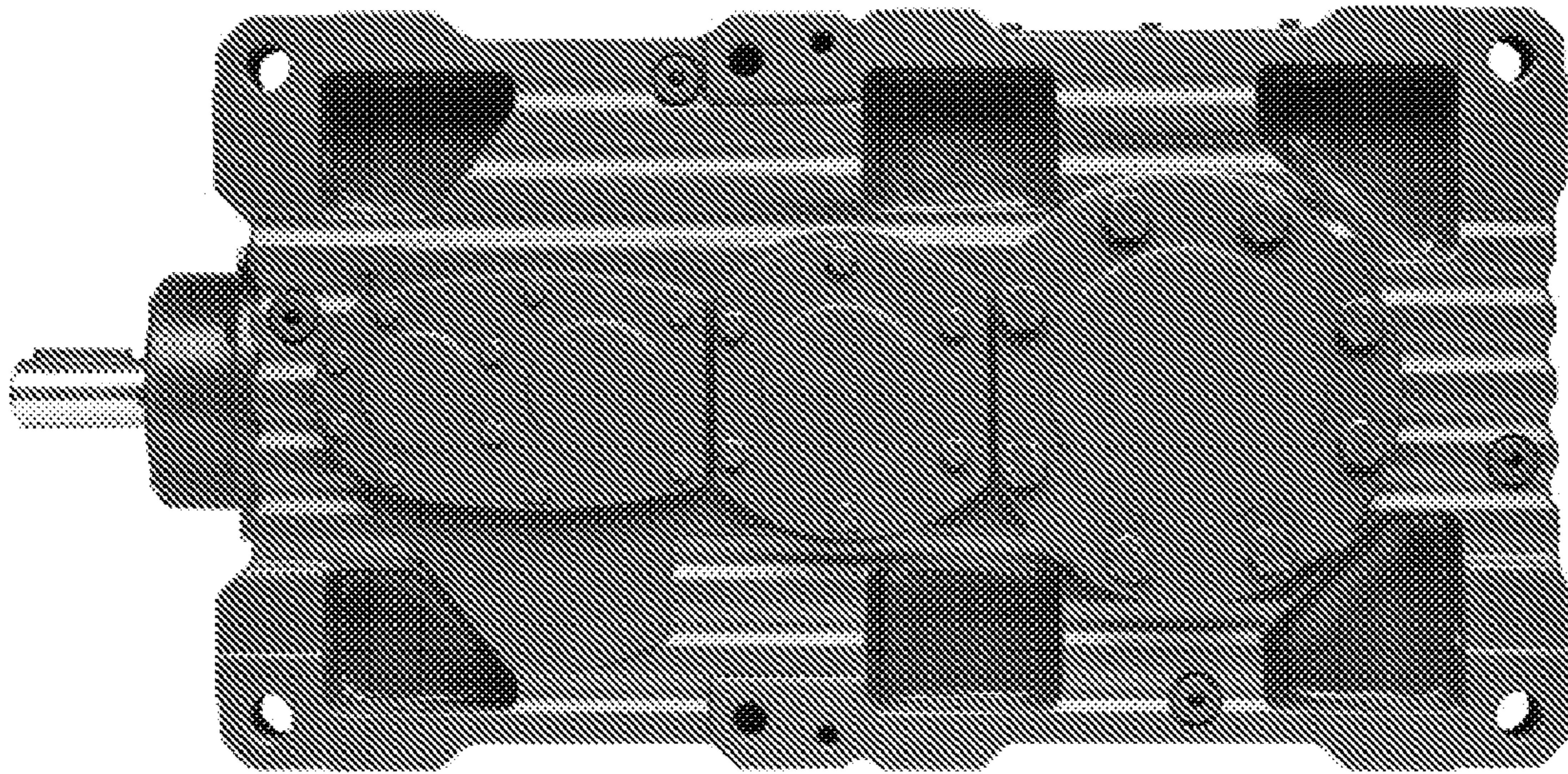

Fig. 9

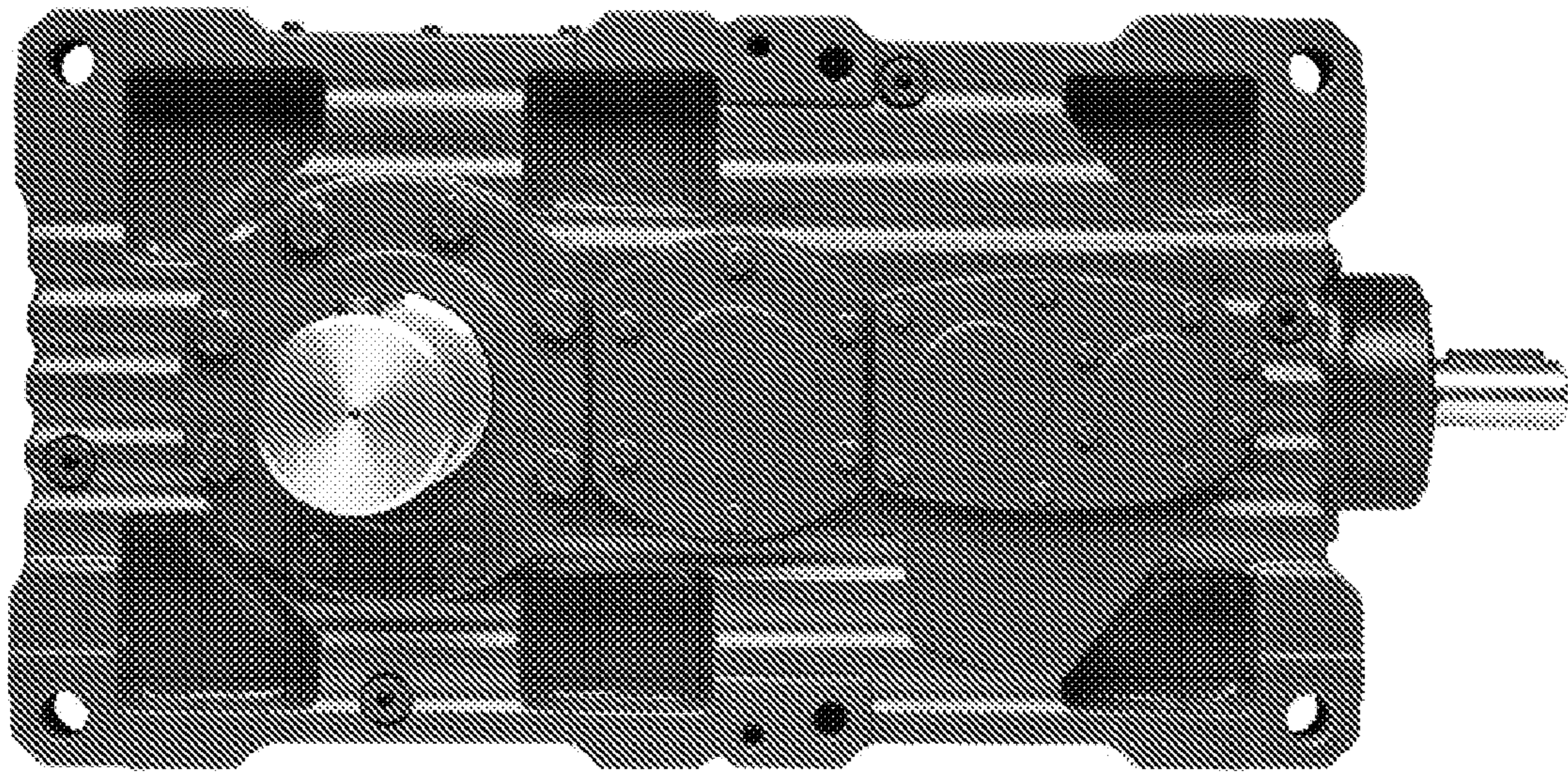

Fig. 10

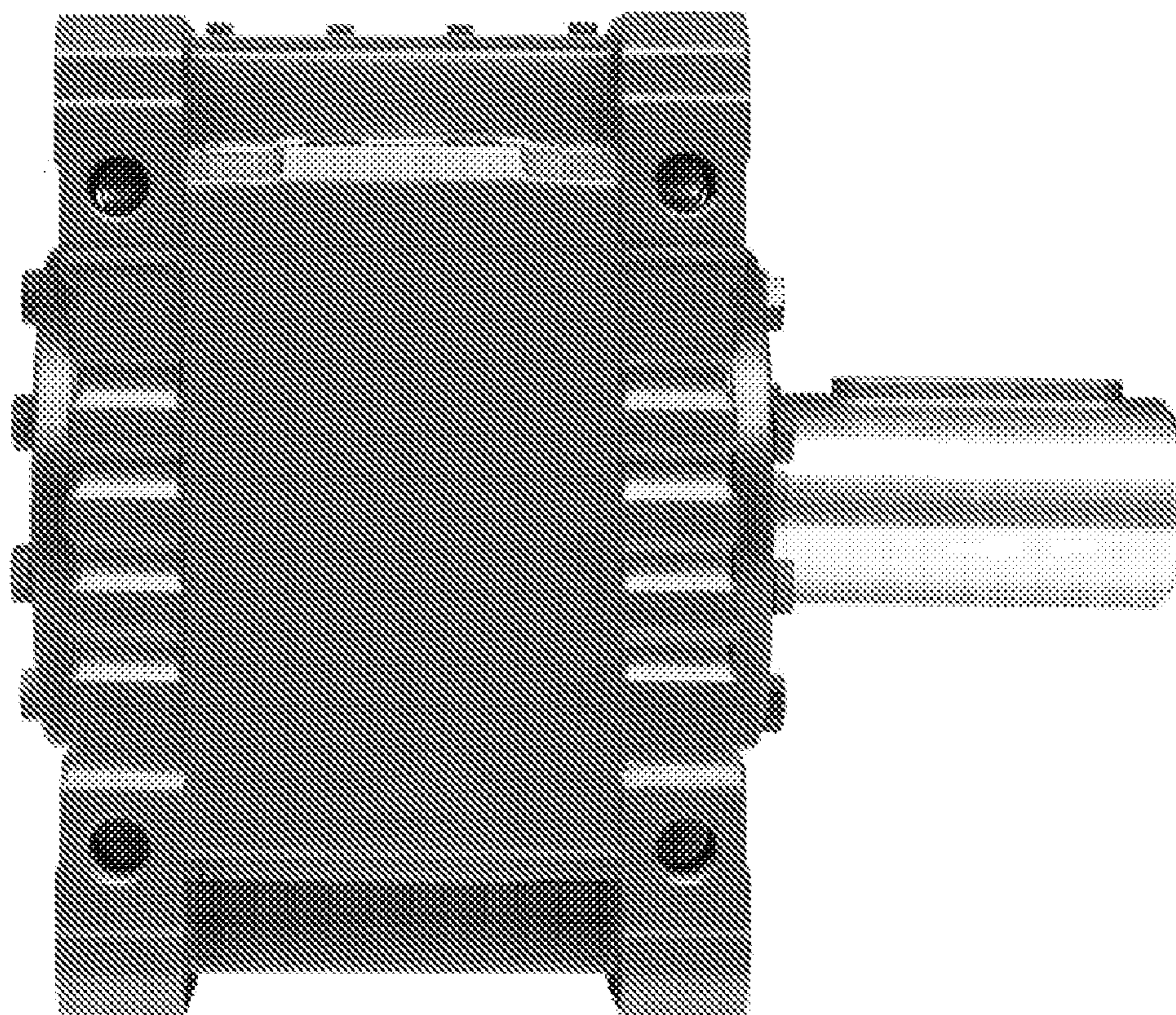

Fig. 11

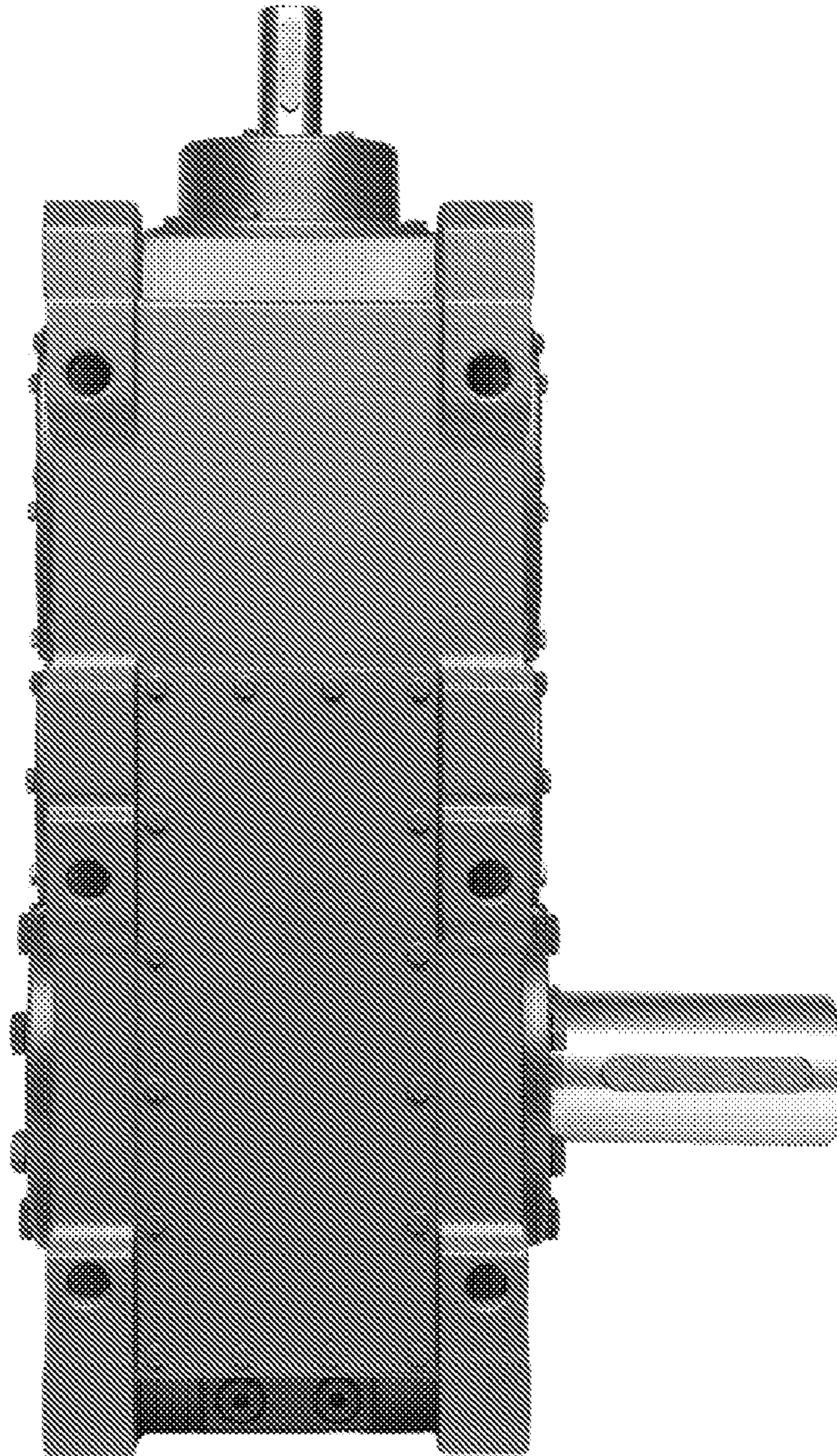

Fig. 12

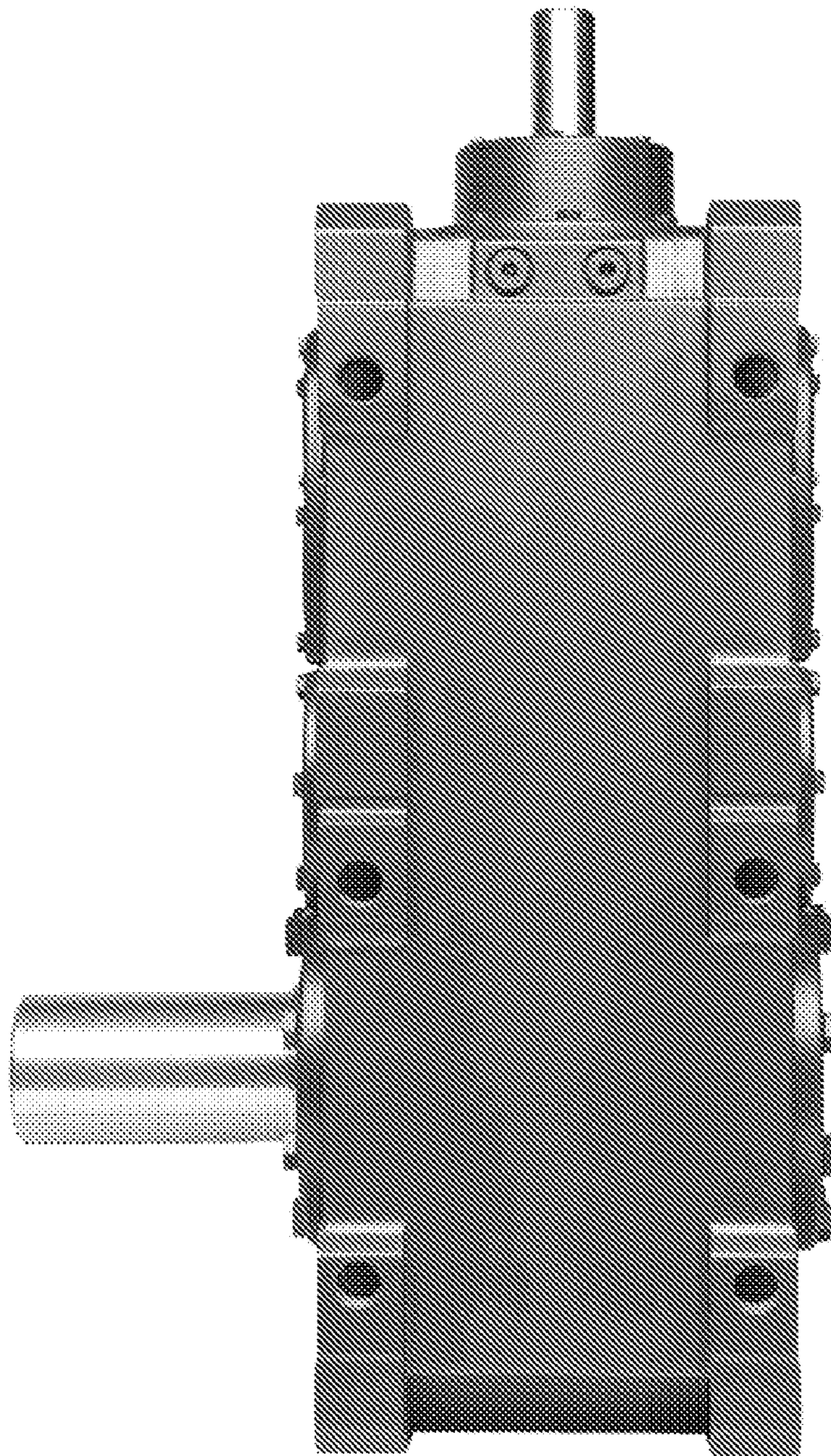

Fig. 13

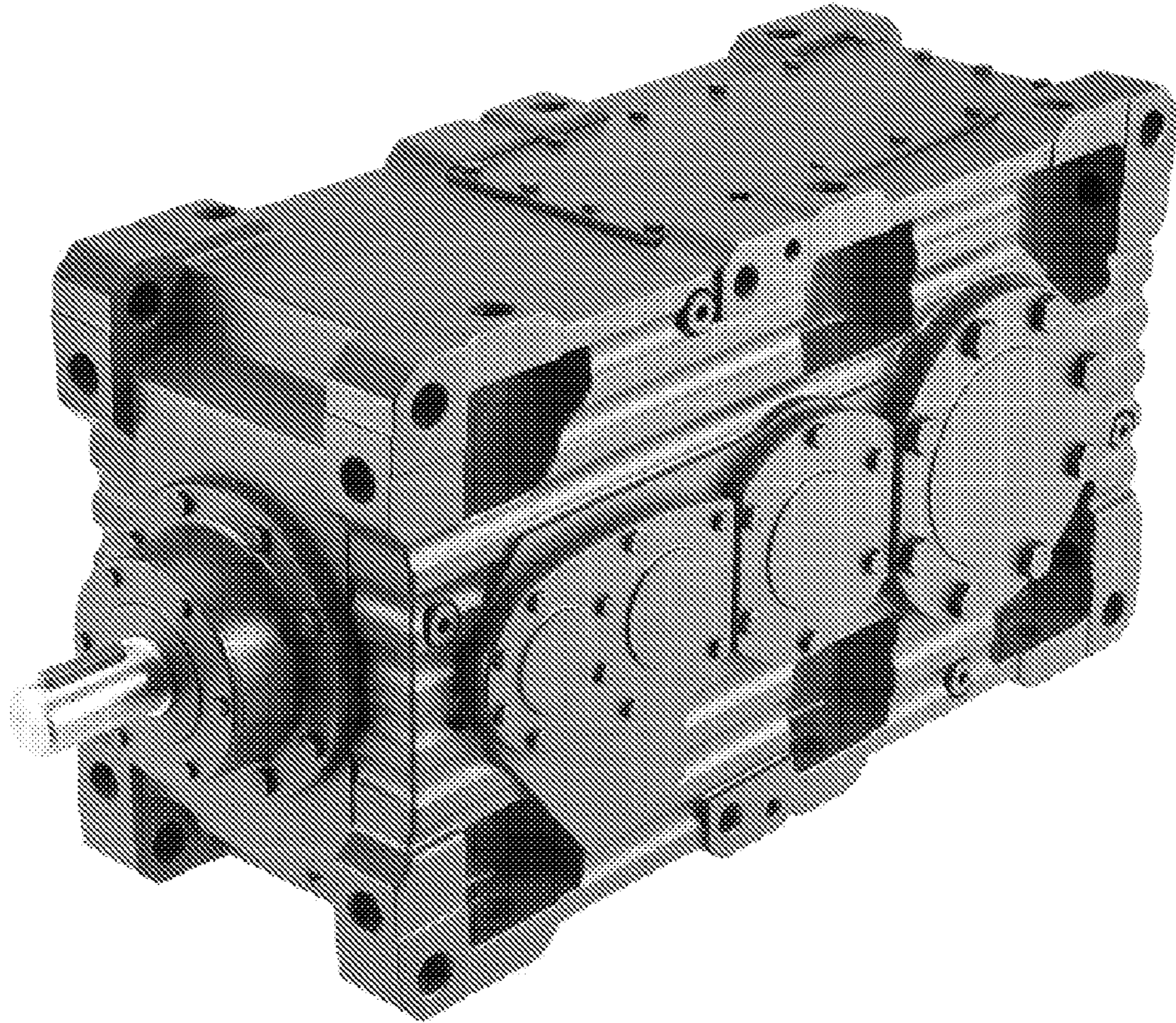

Fig. 14



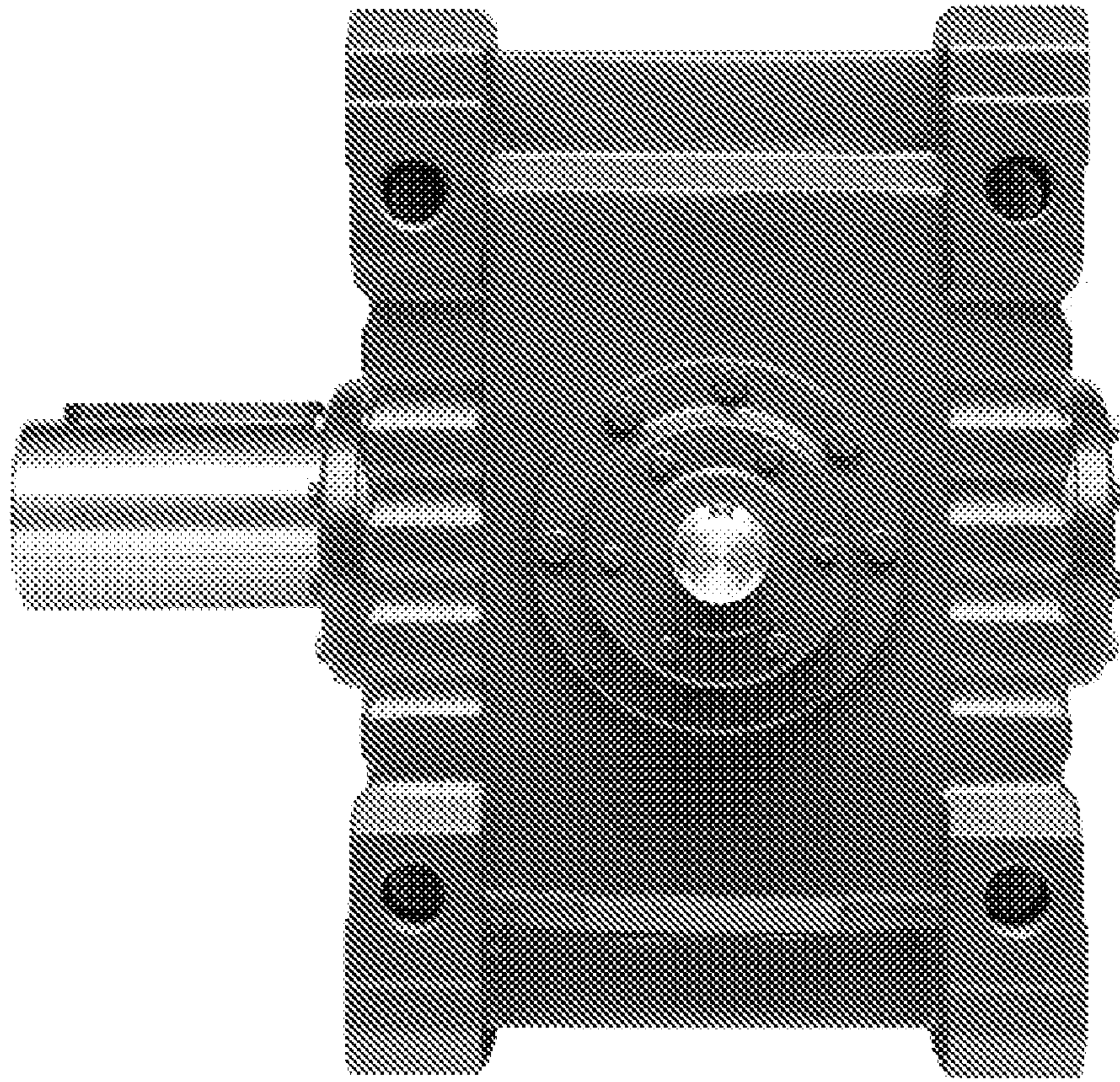

Fig. 15

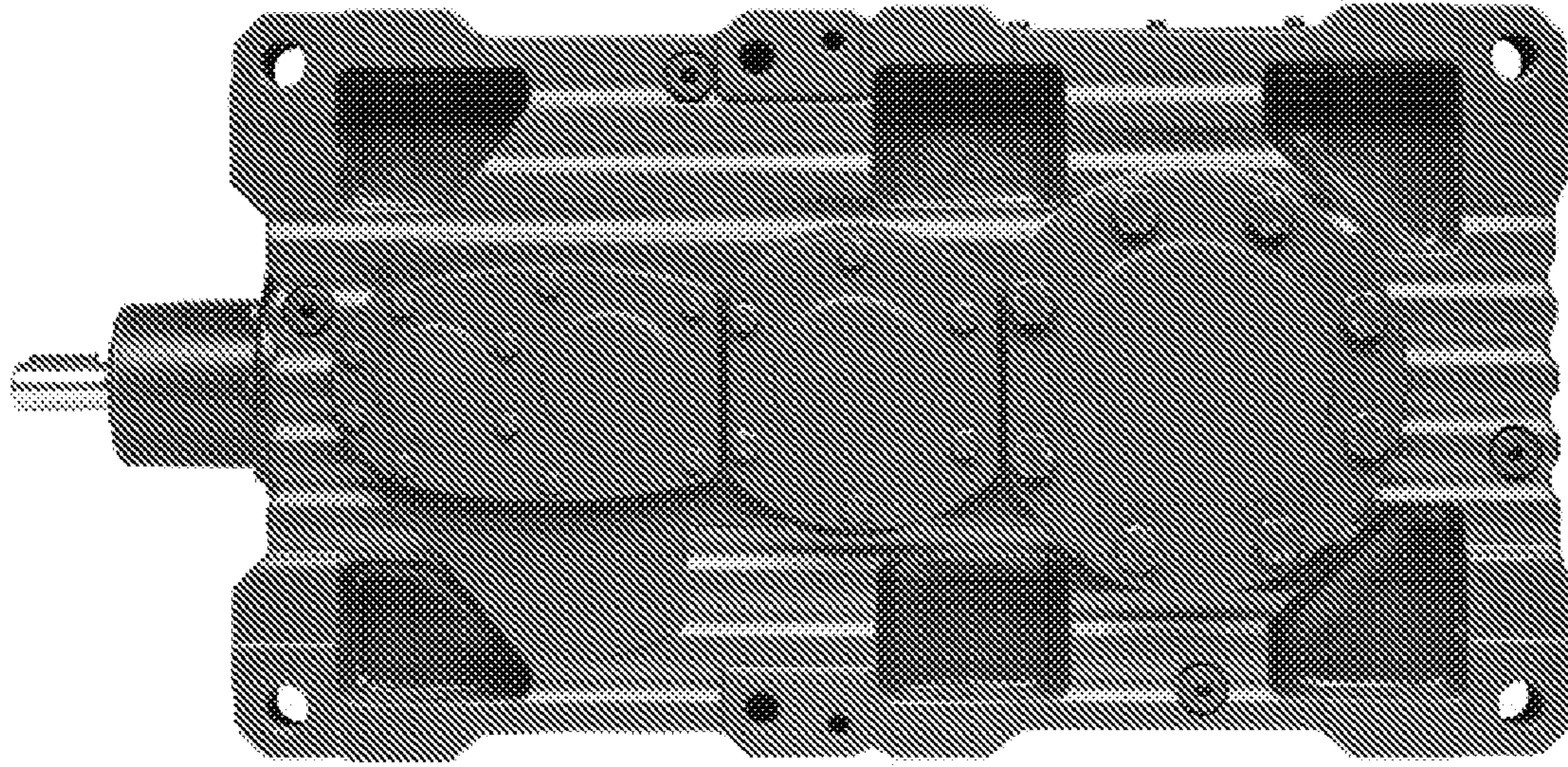

Fig. 16

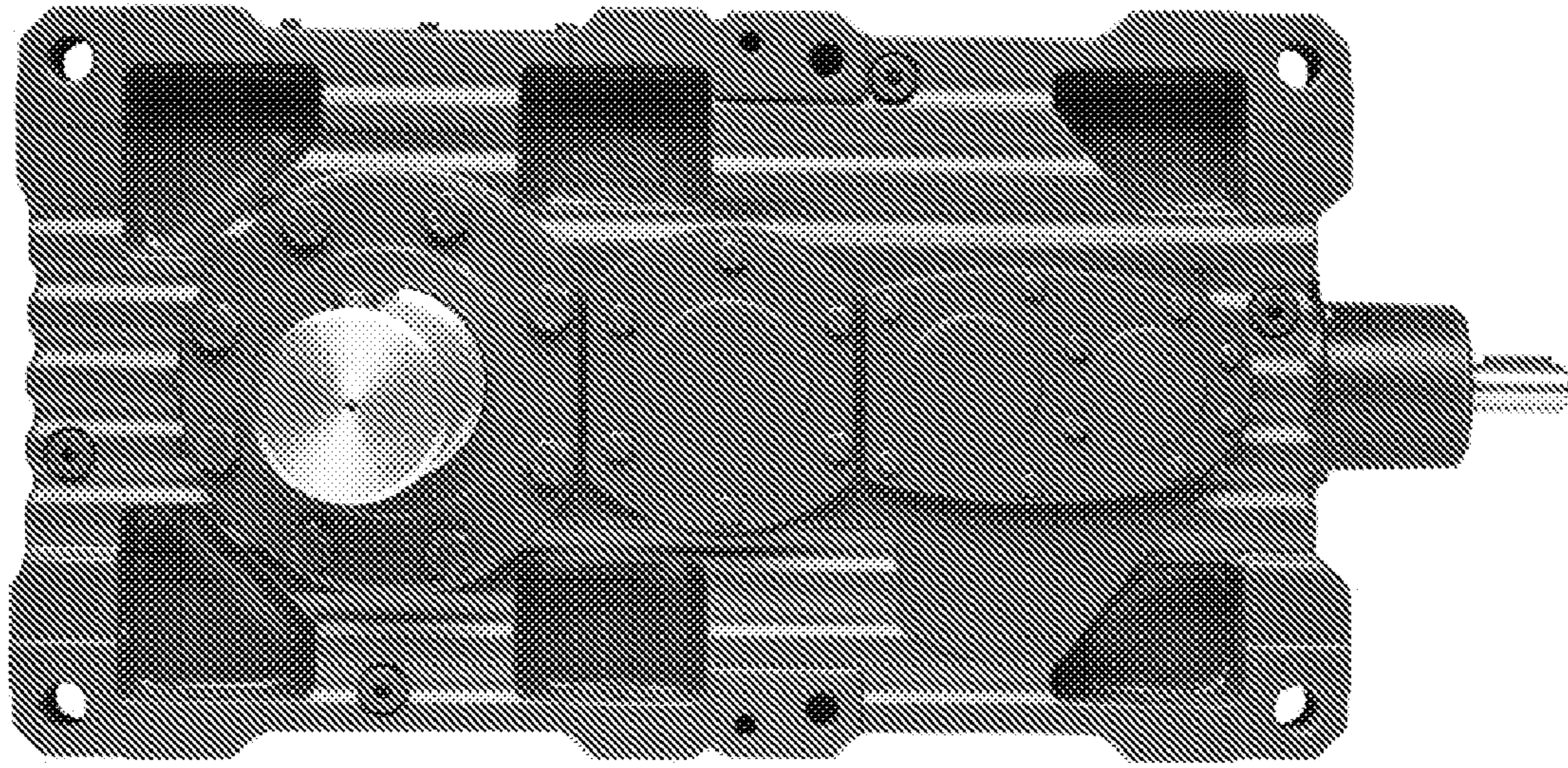

Fig. 17

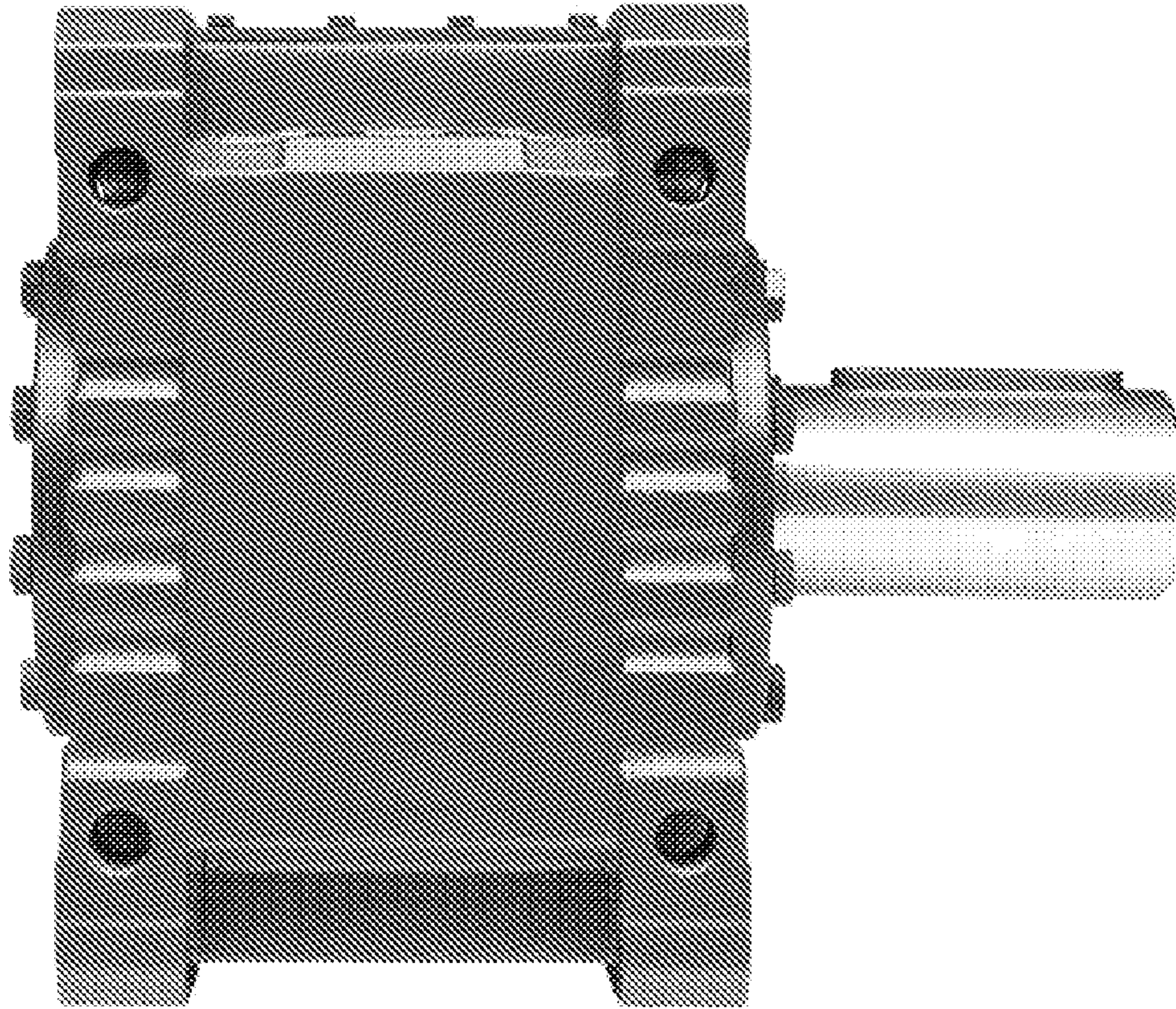

Fig. 18

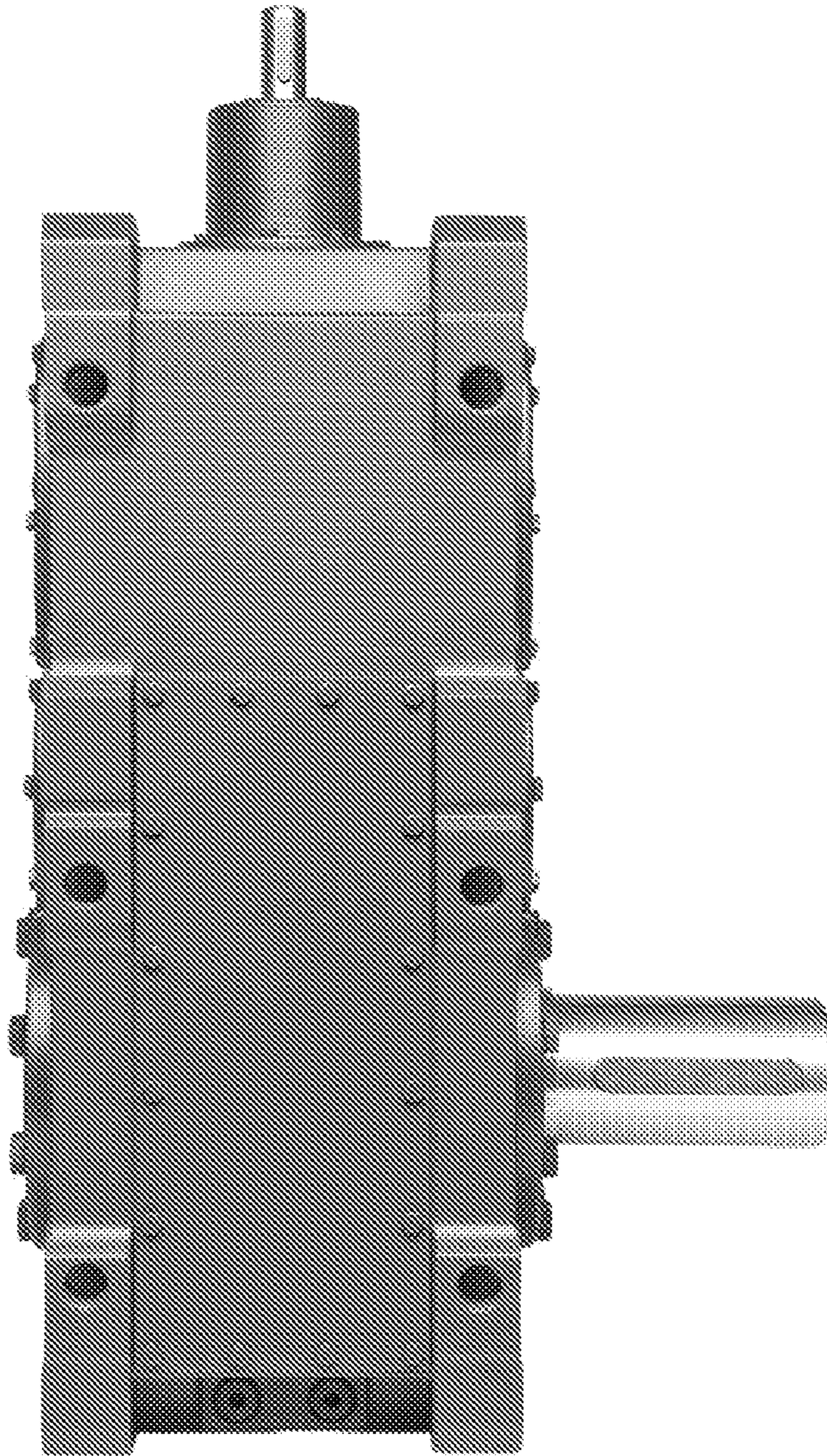

Fig. 19

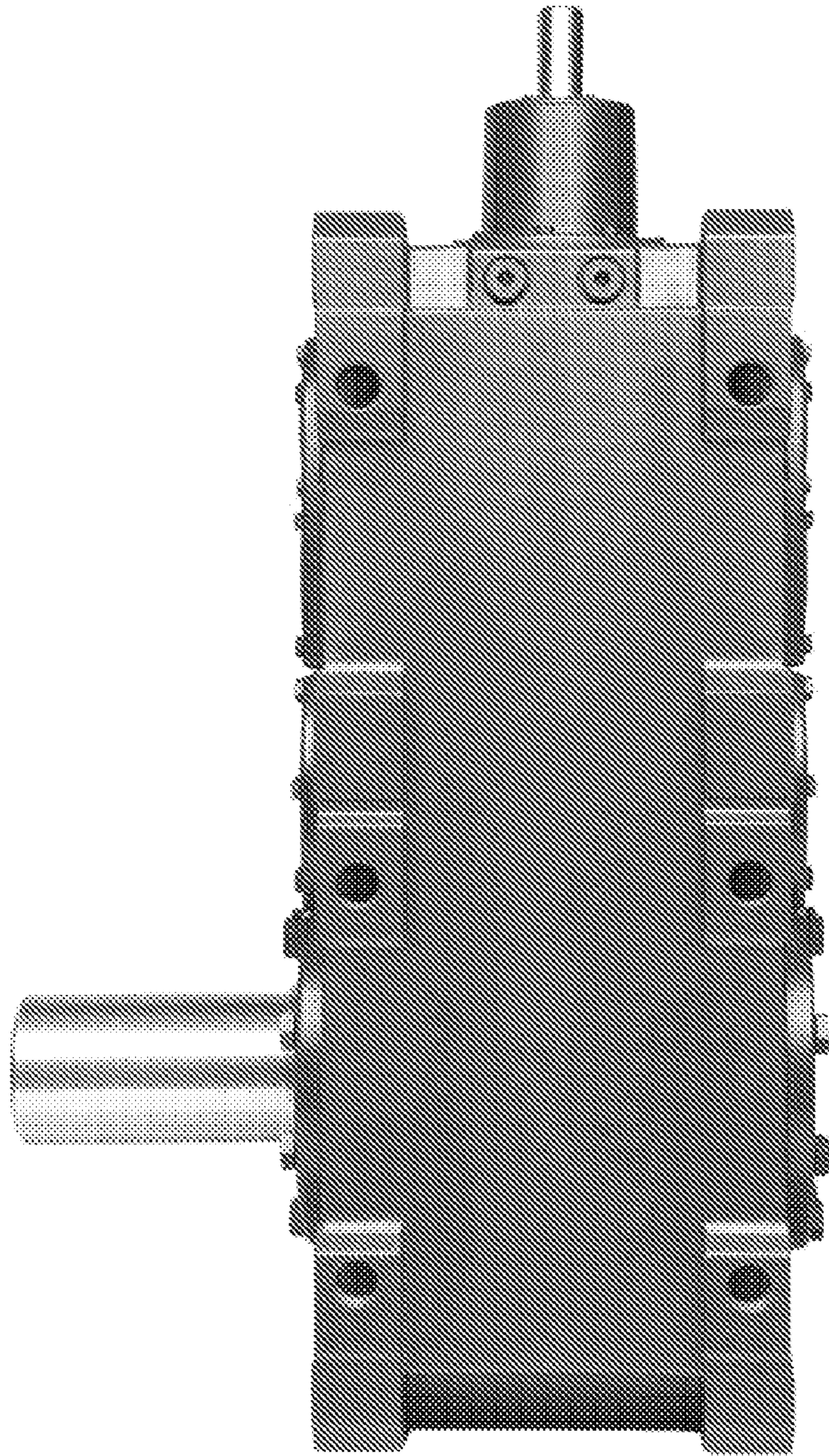

Fig. 20

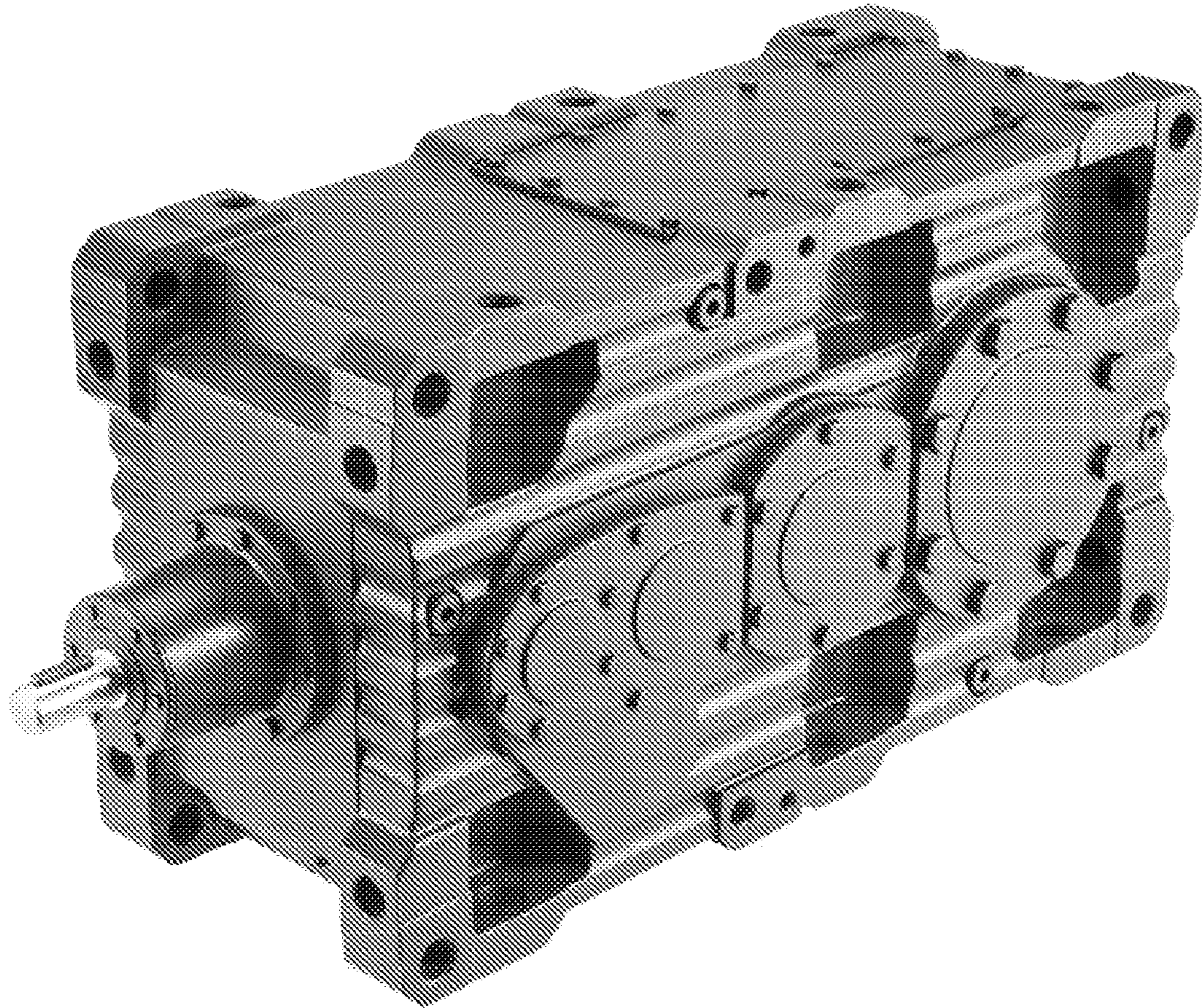

Fig. 21

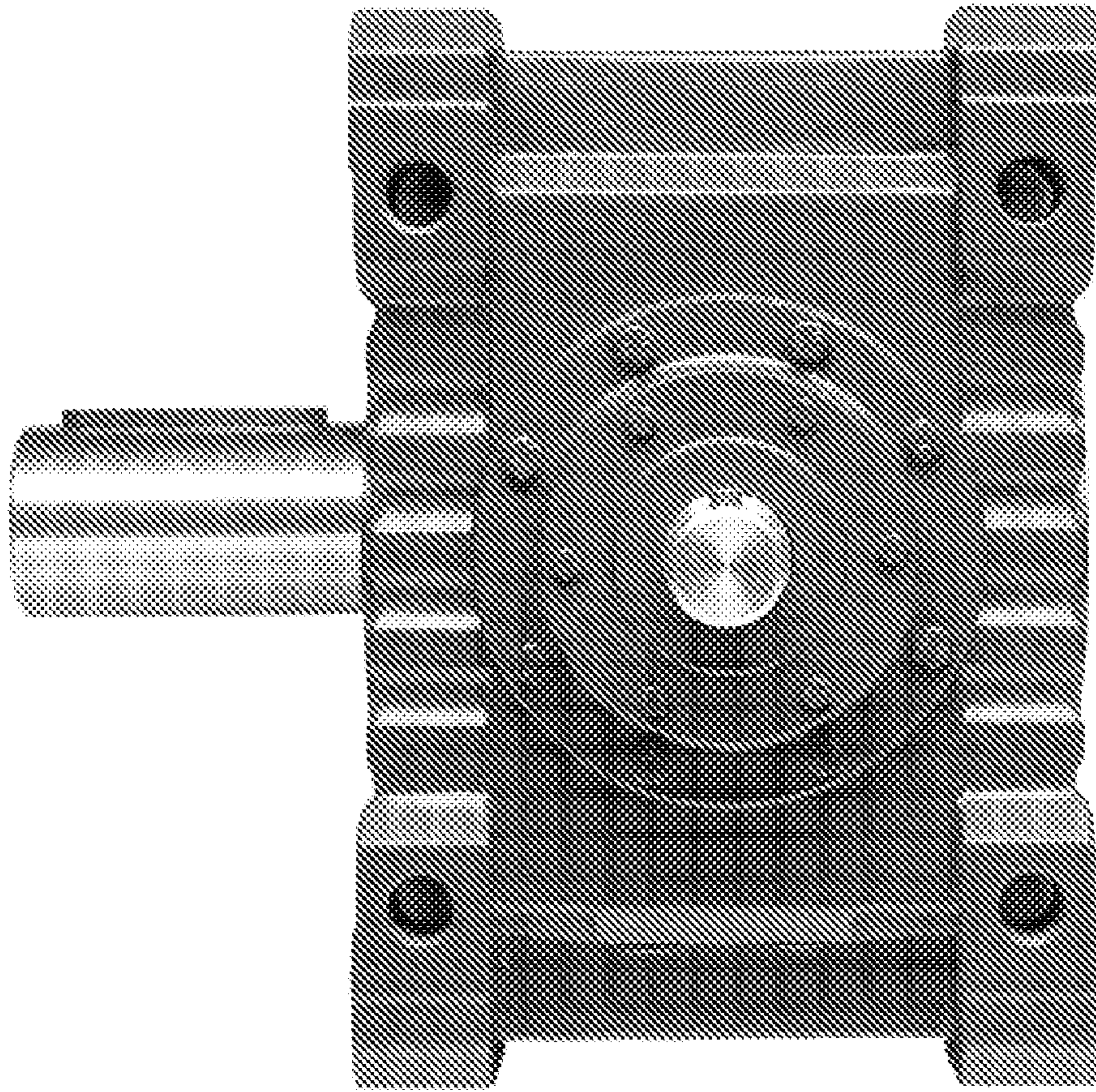

Fig. 22



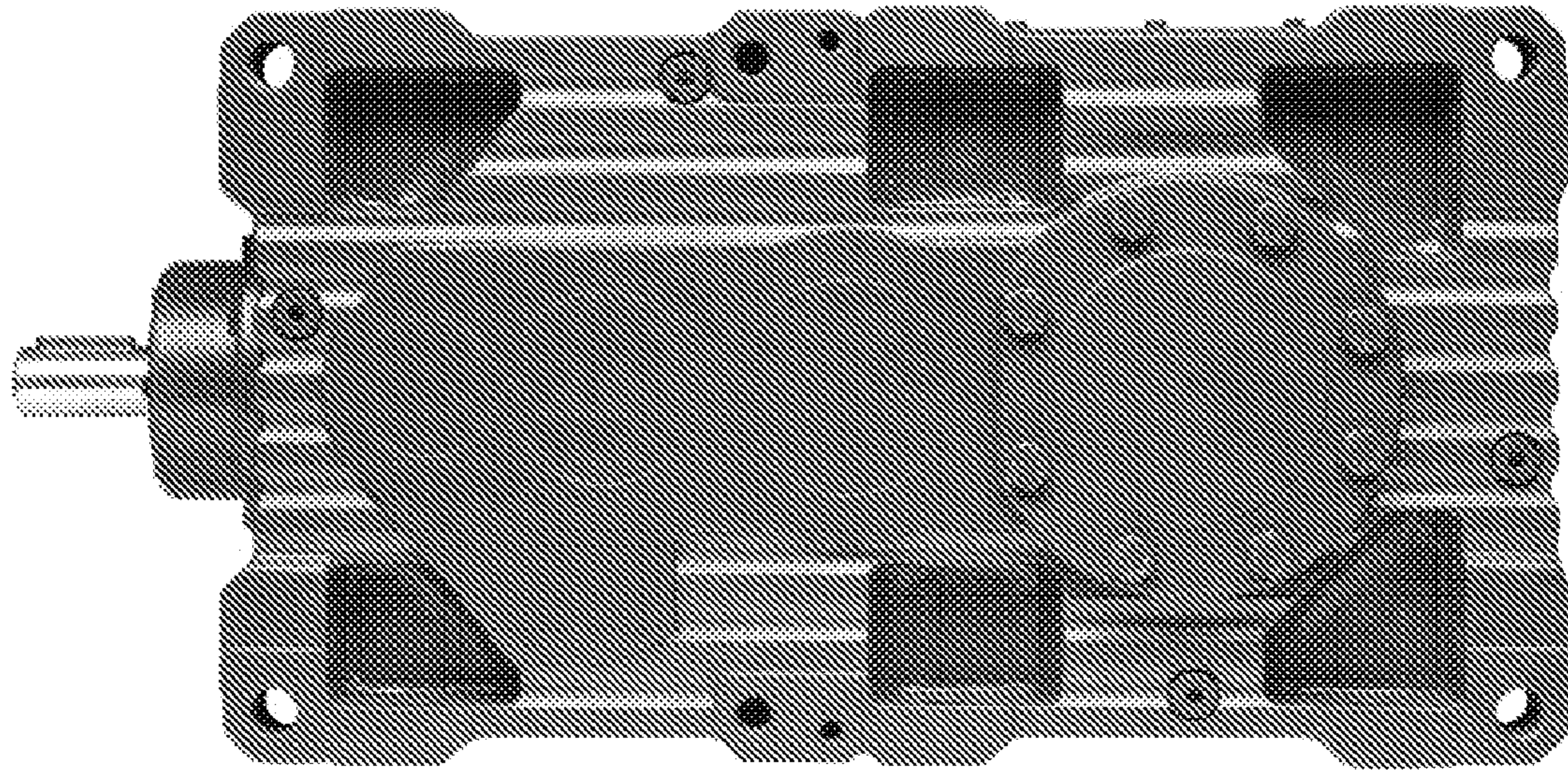

Fig. 23

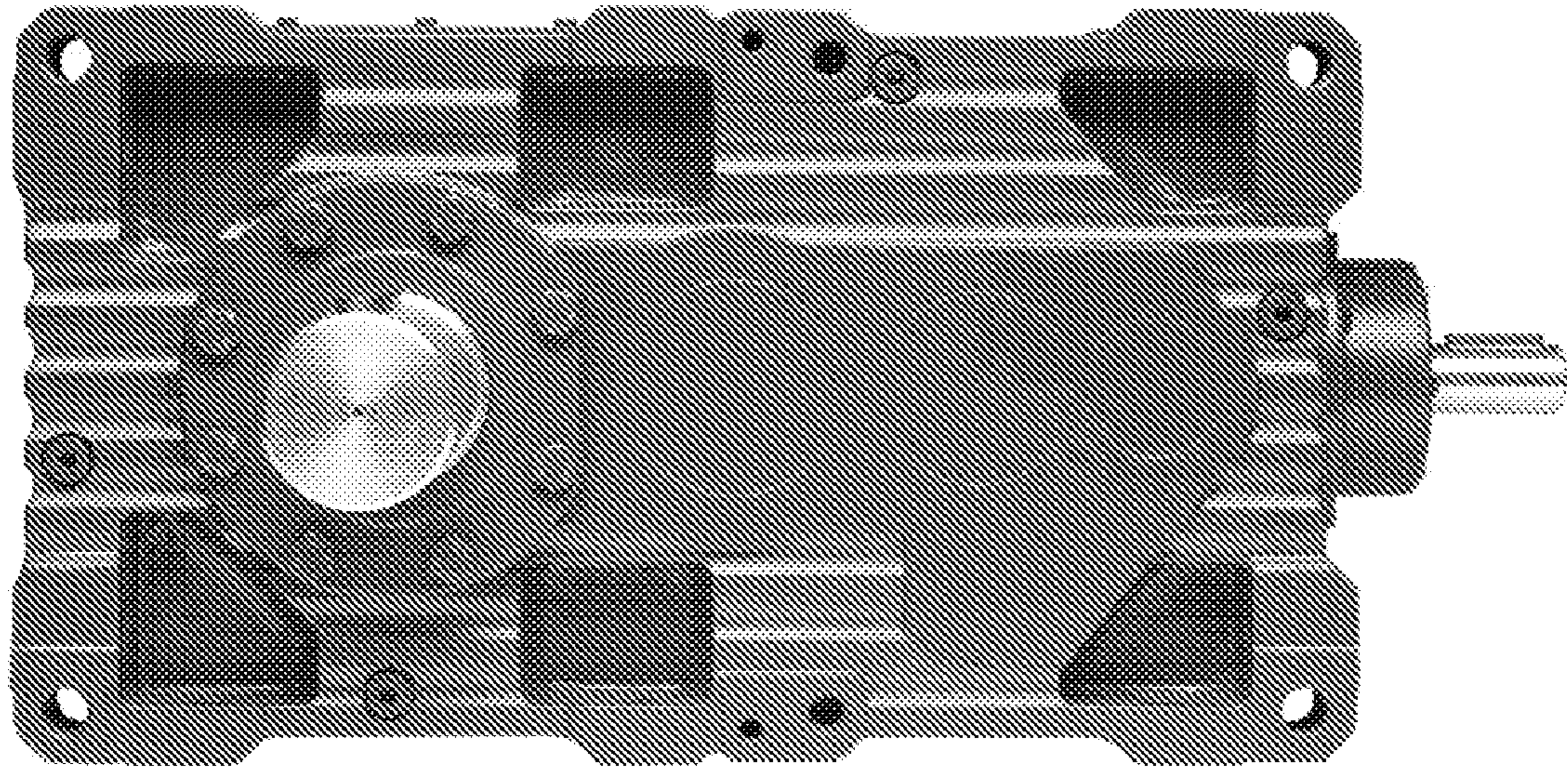

Fig. 24

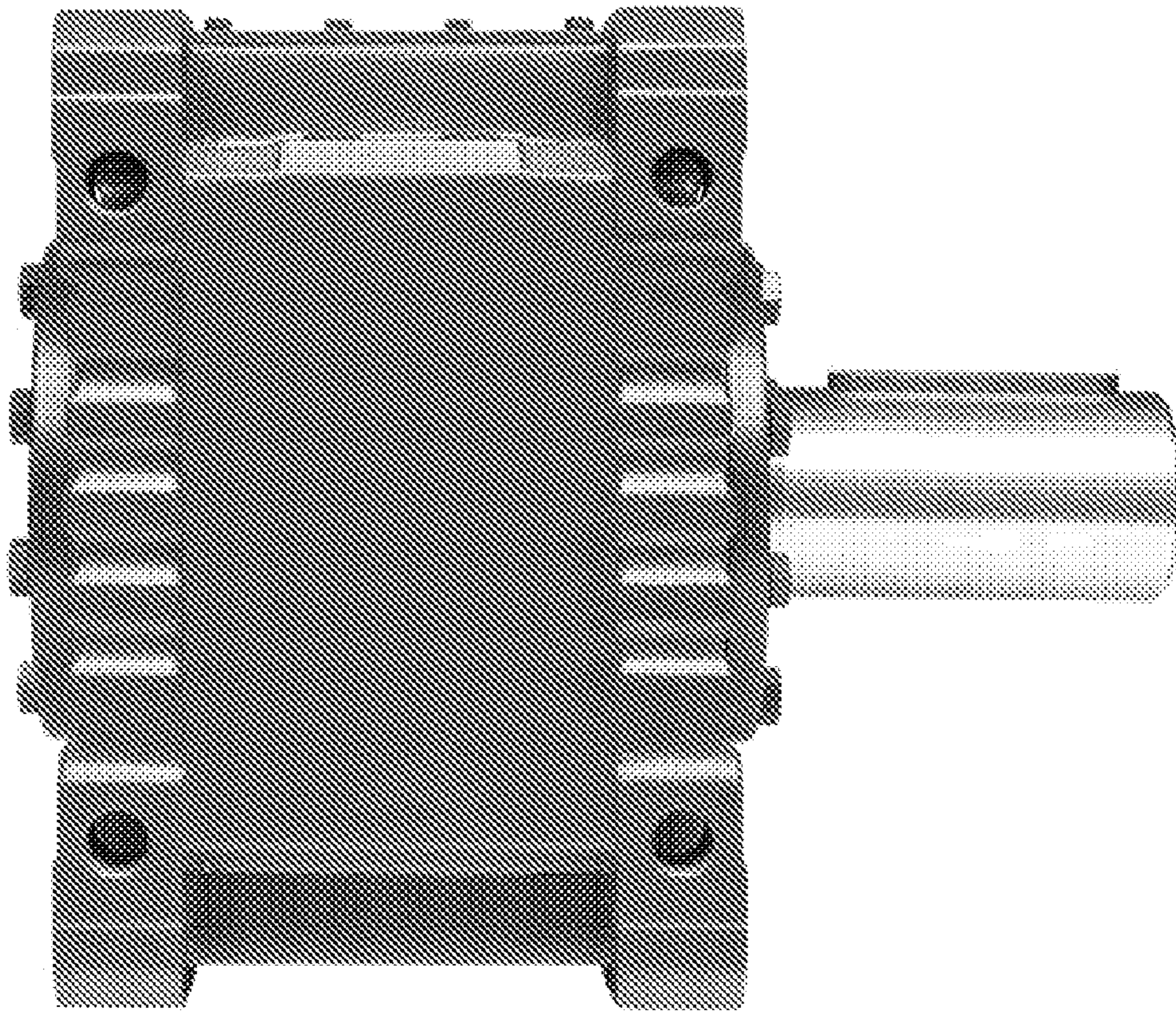

Fig. 25

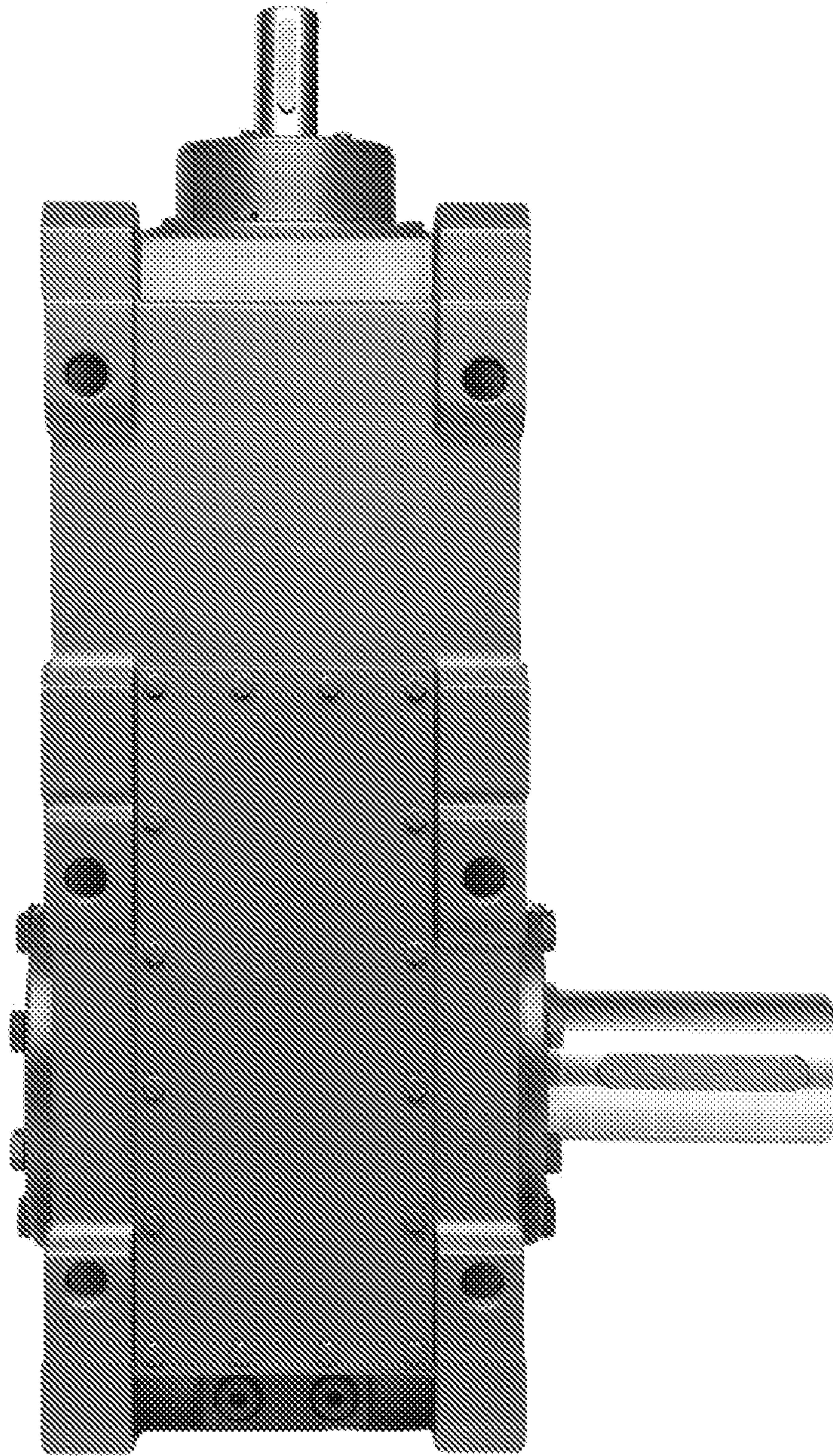

Fig. 26

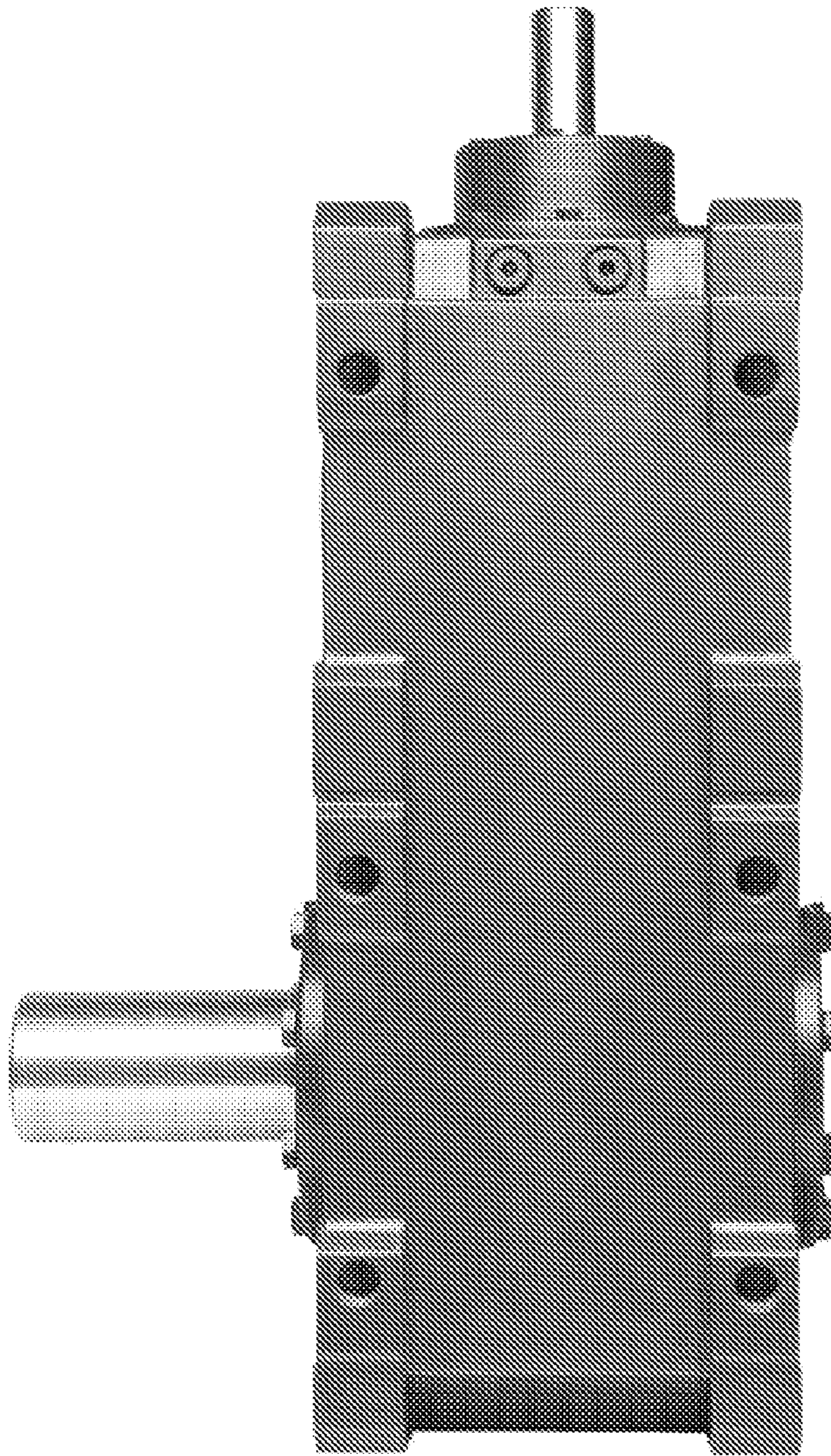

Fig. 27

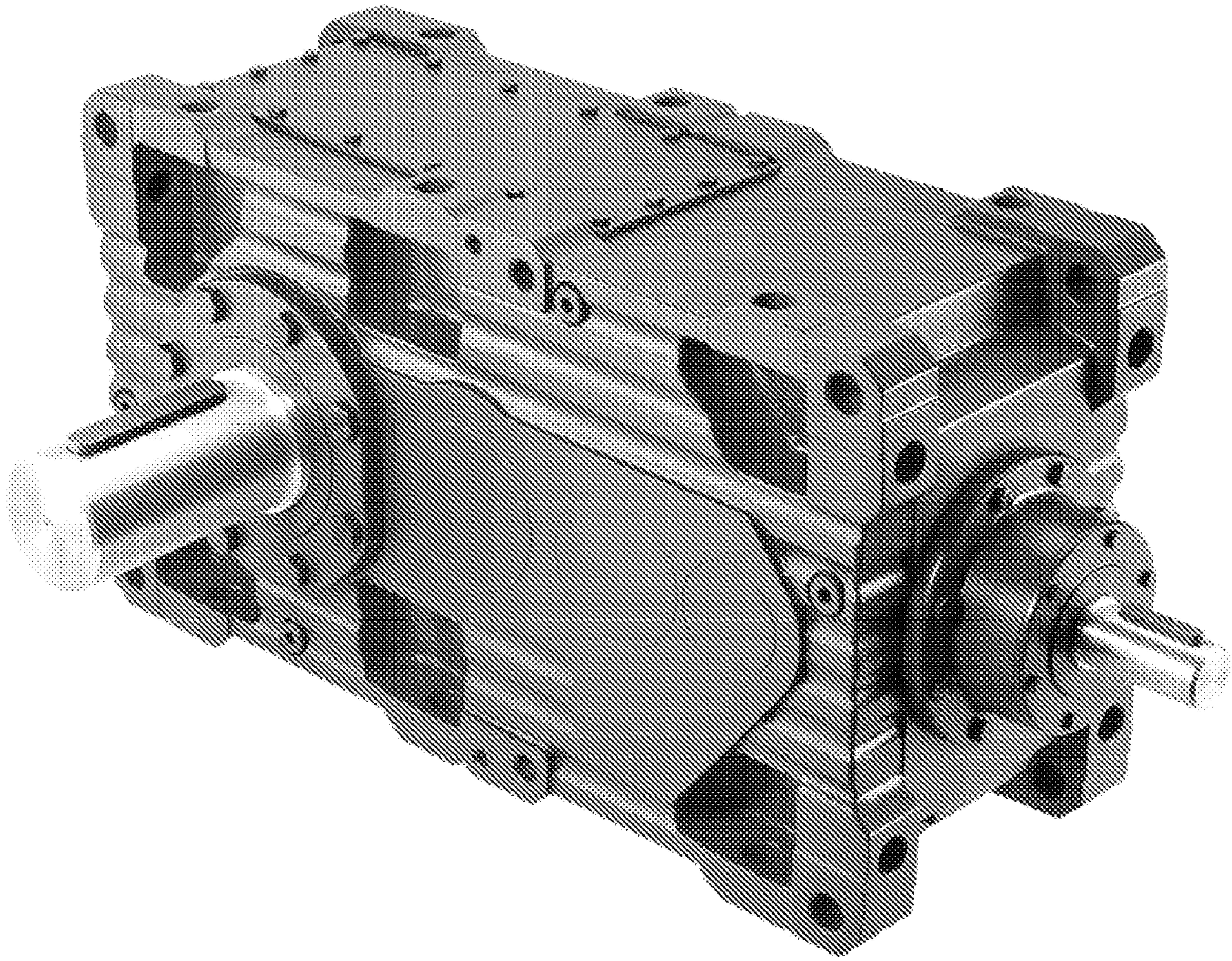

Fig. 28

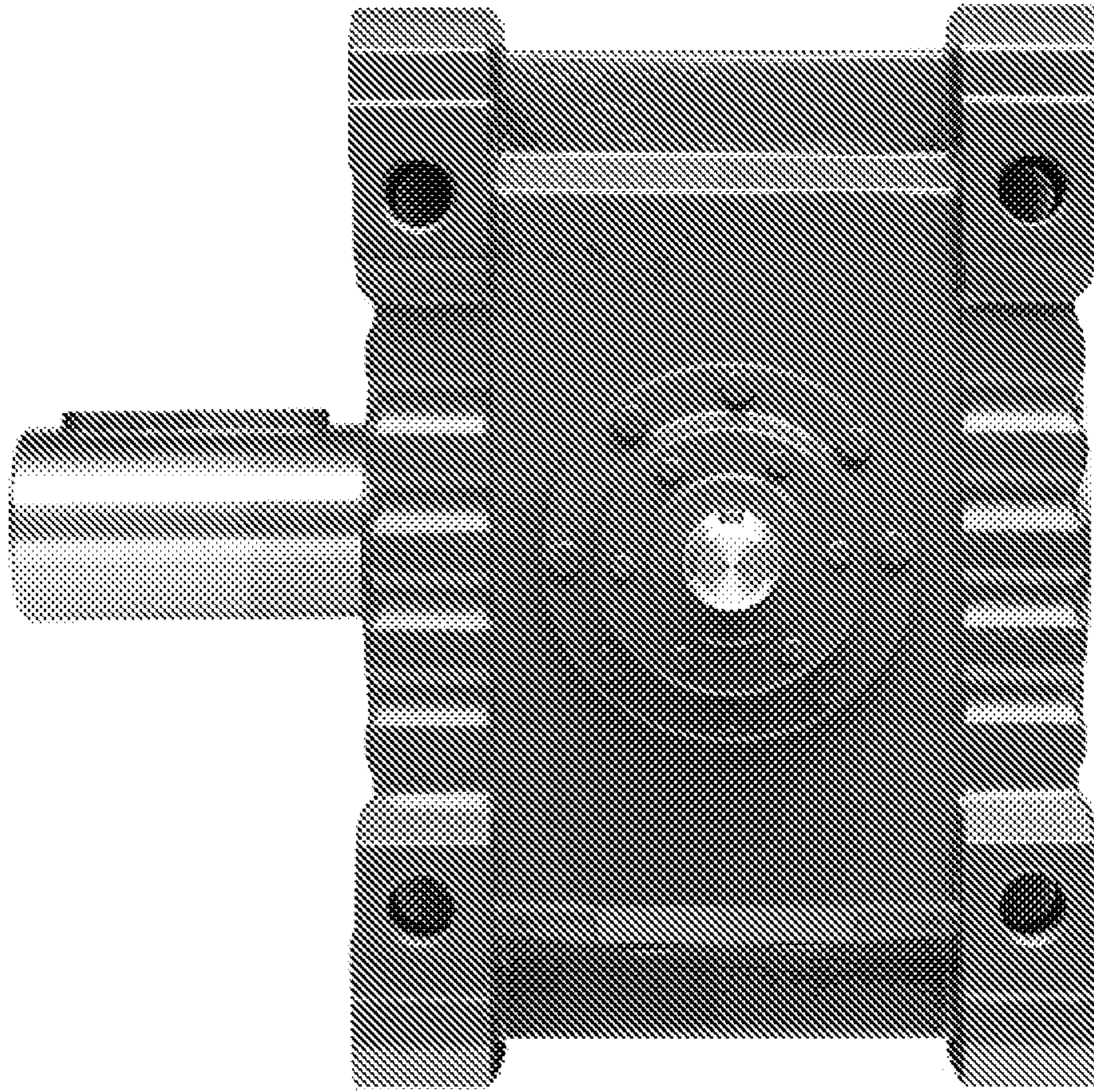

Fig. 29

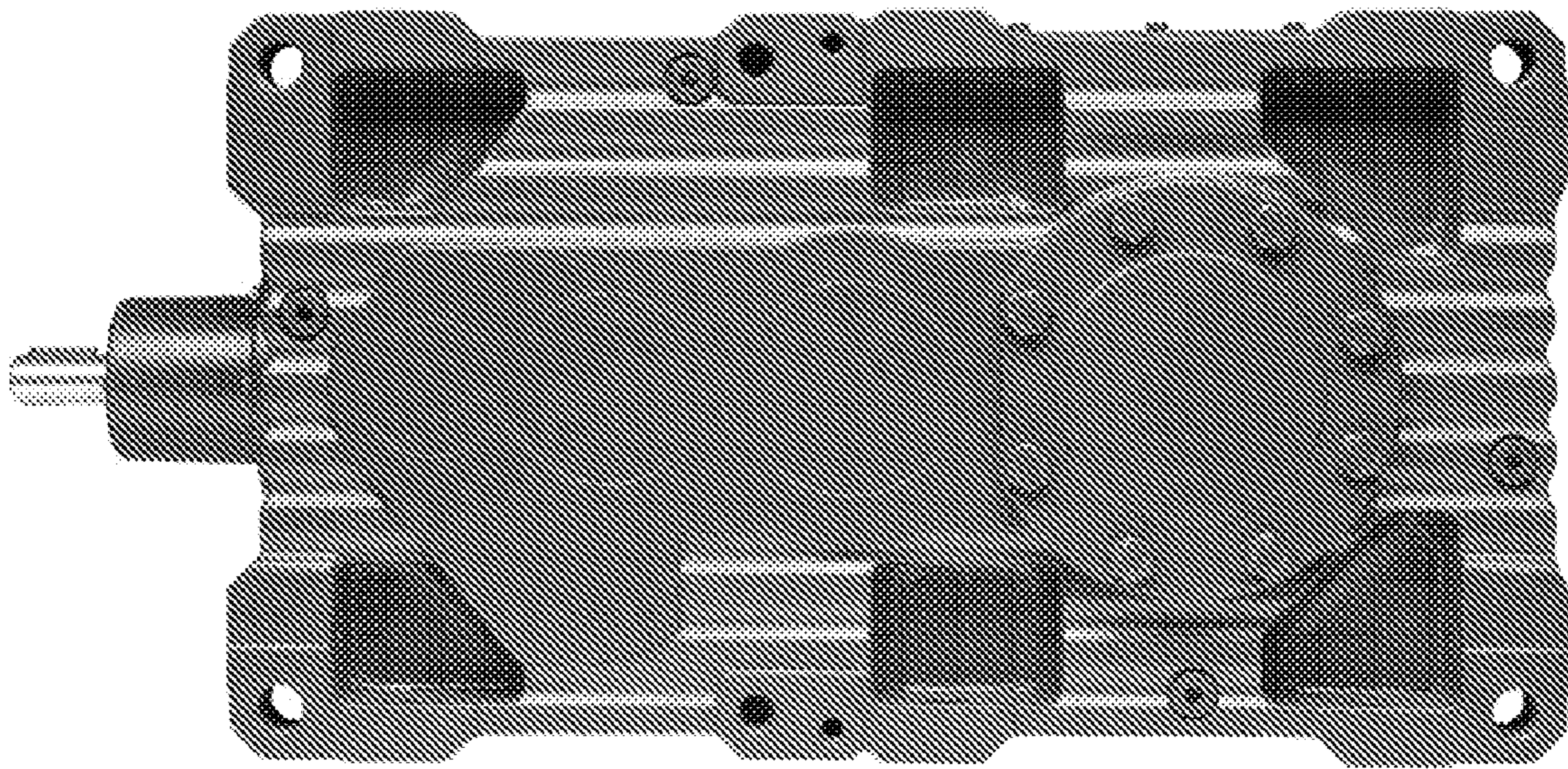

Fig. 30



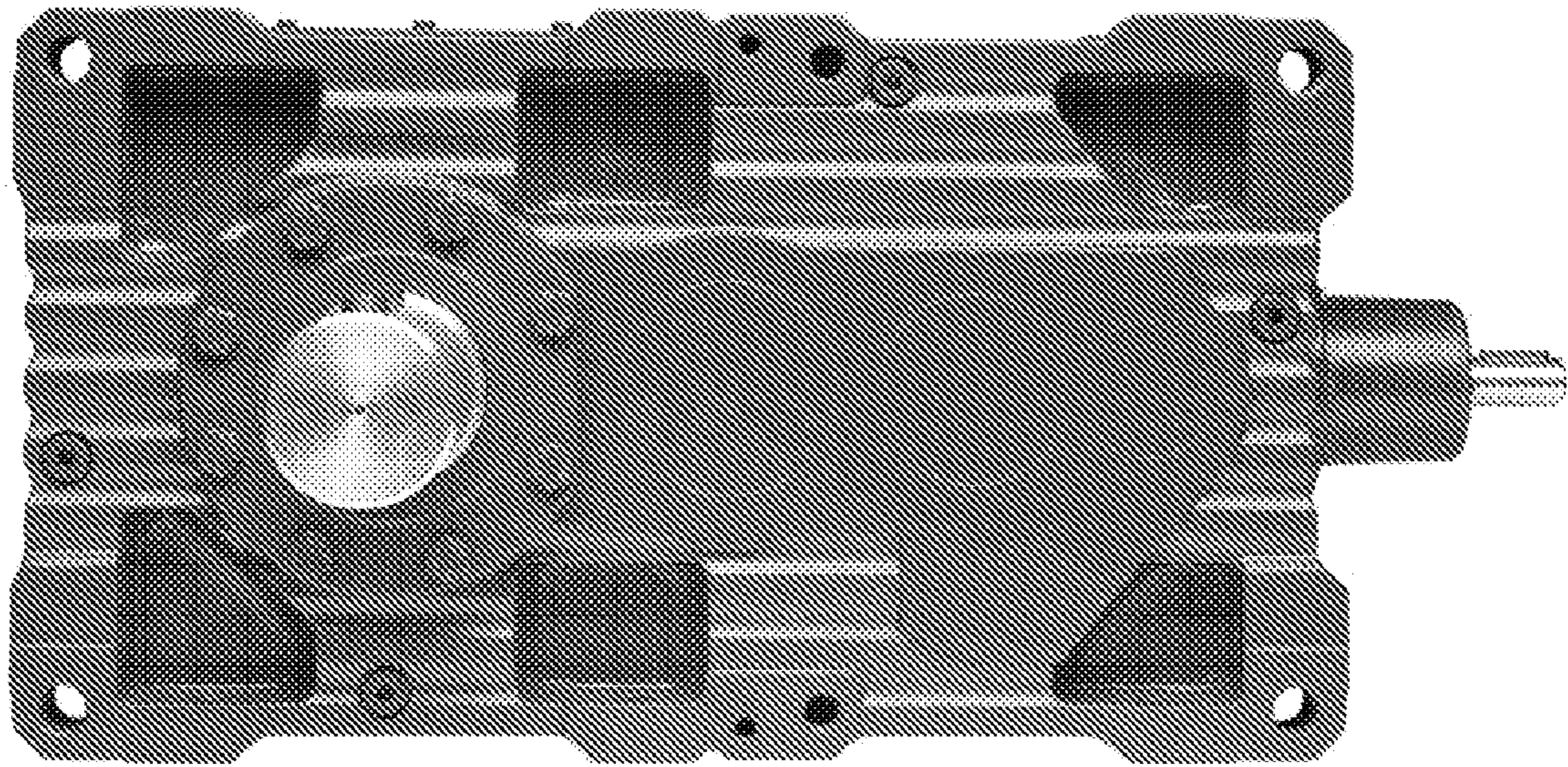

Fig. 31

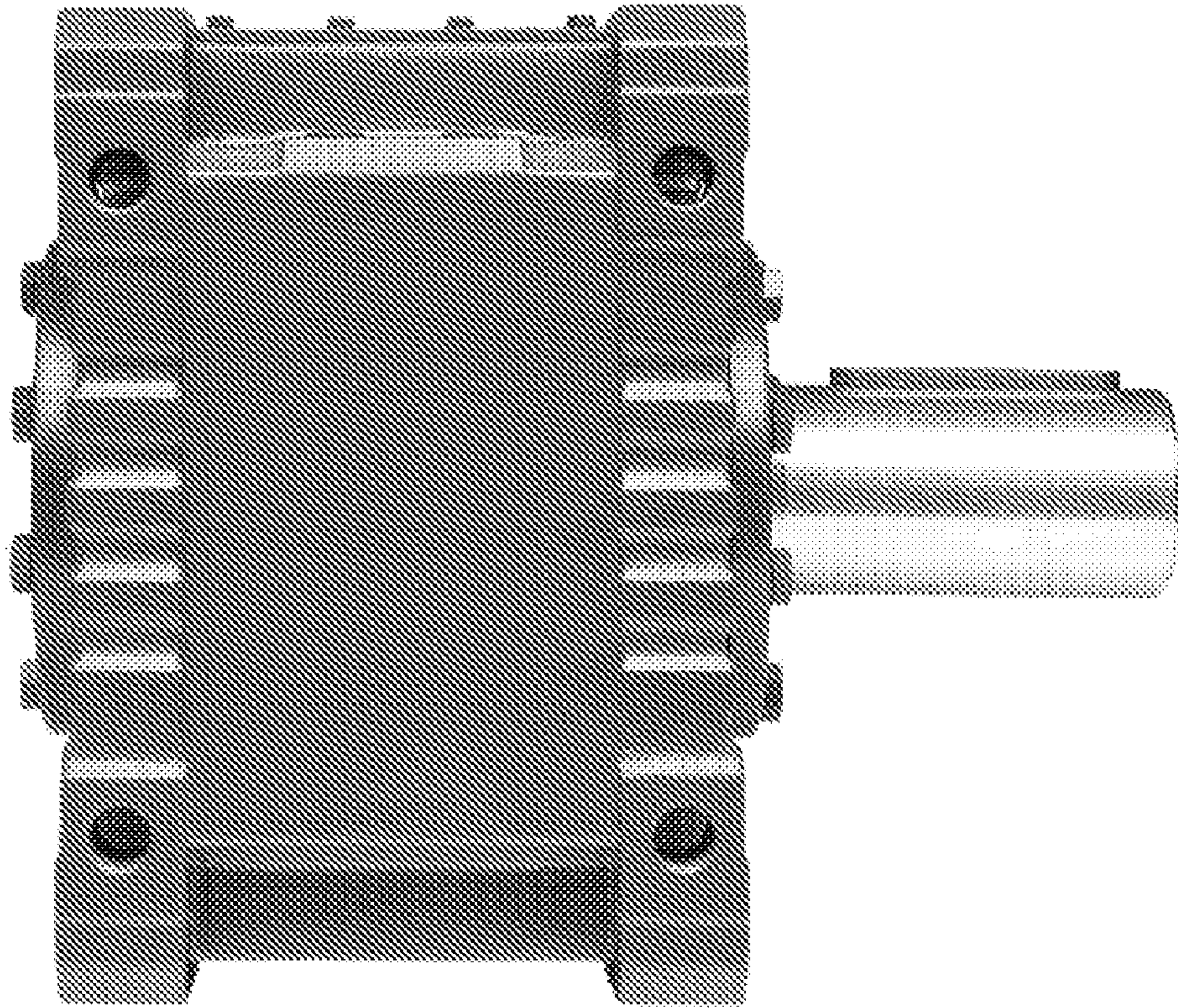

Fig. 32

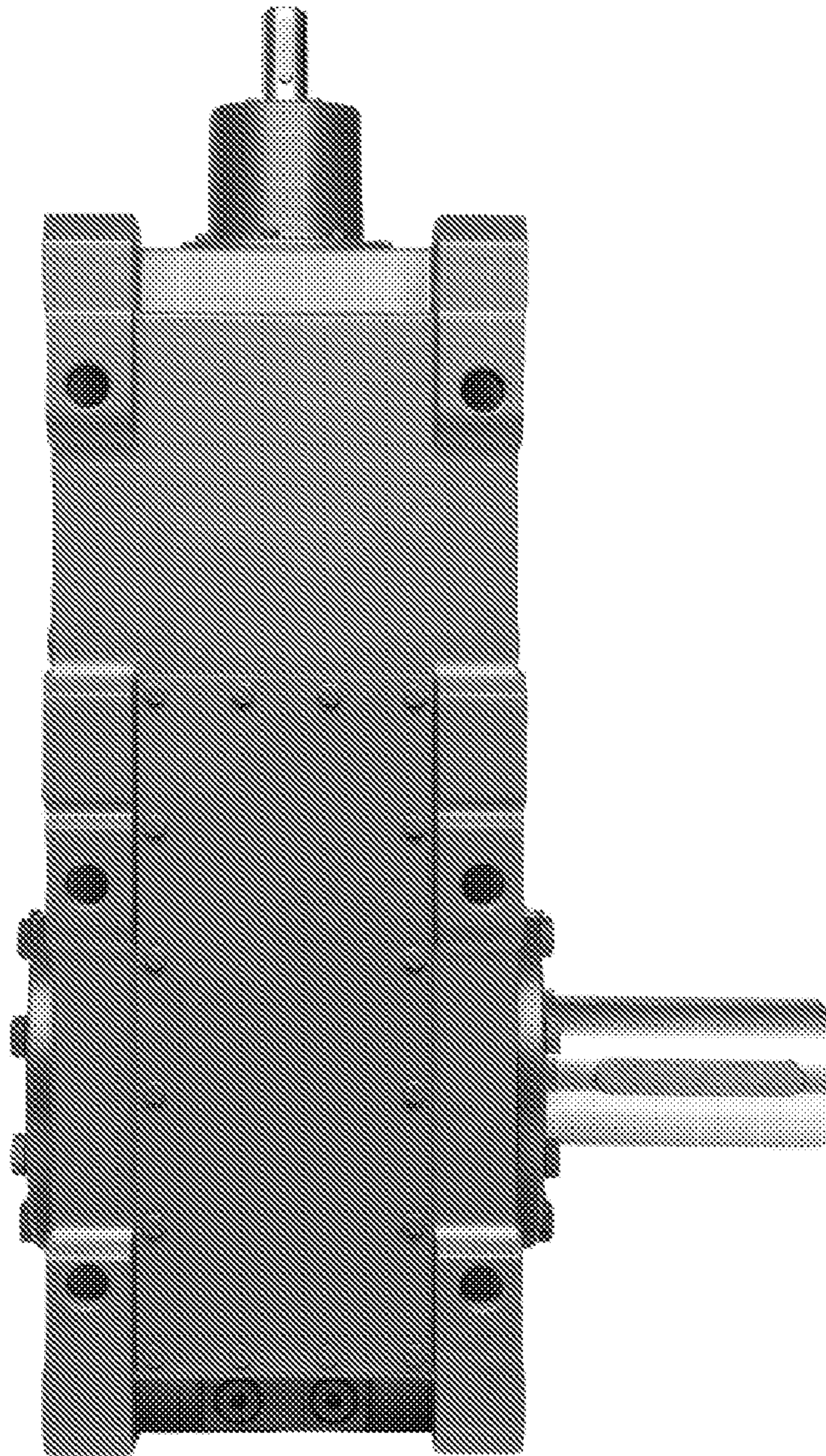

Fig. 33

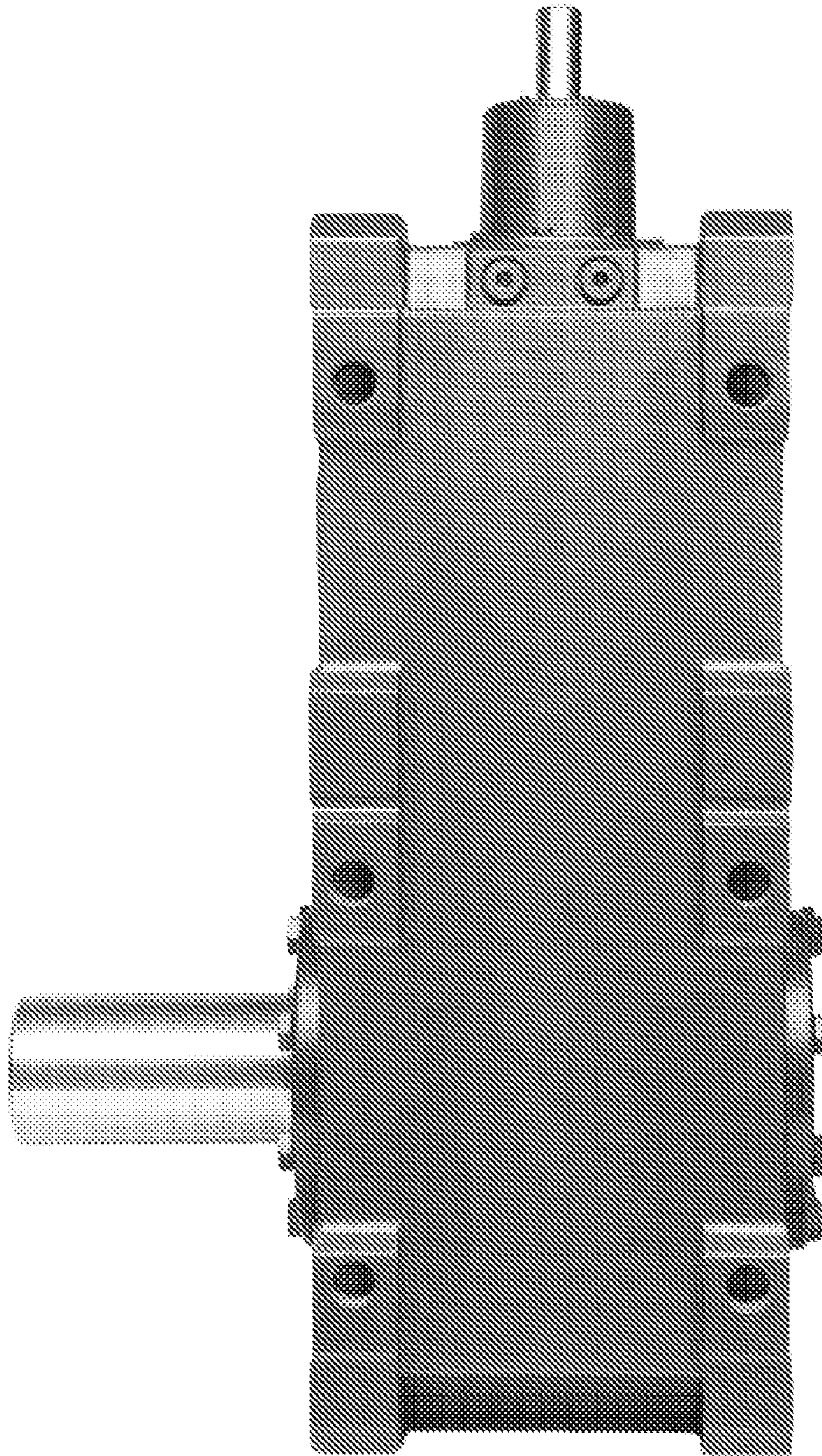

Fig. 34

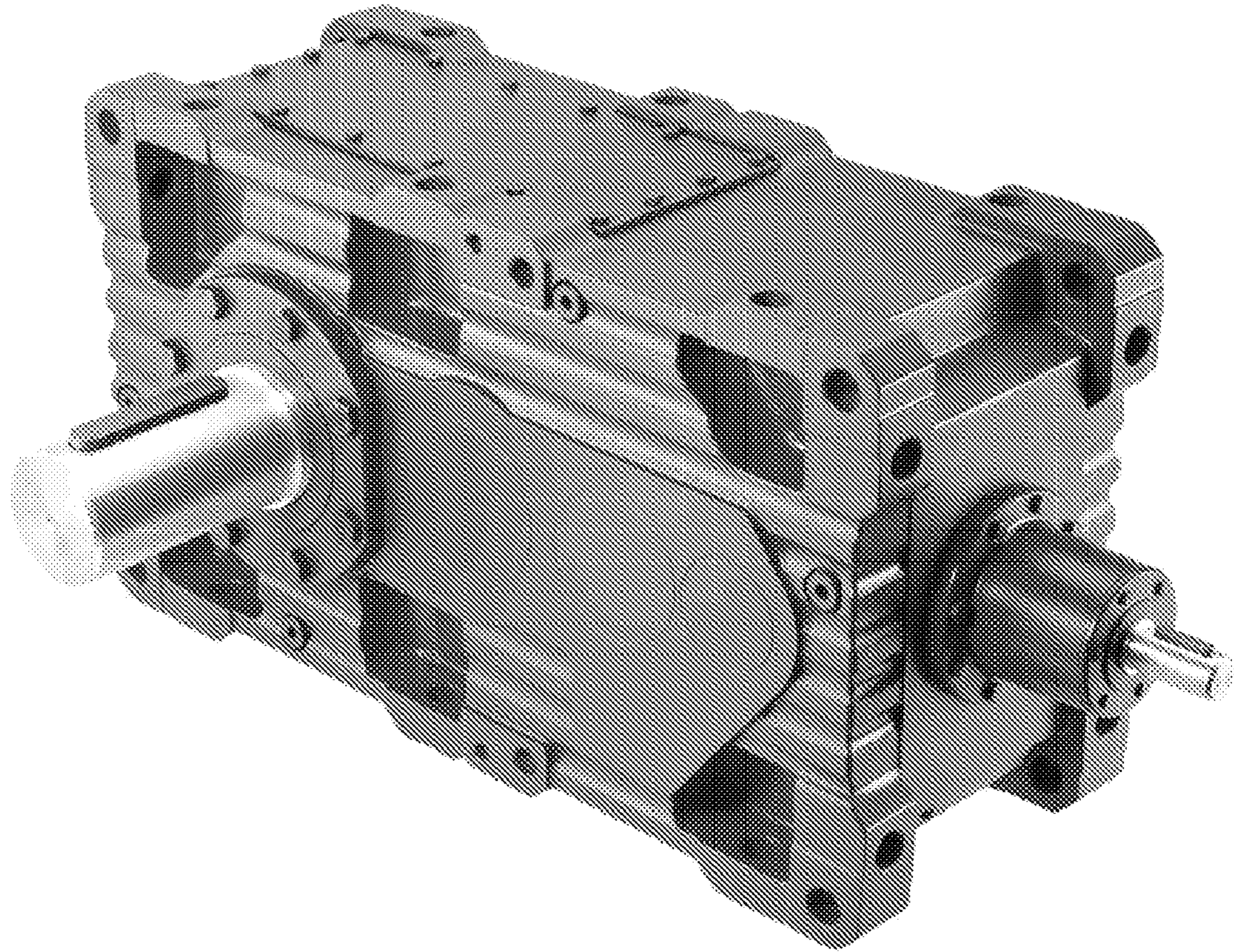

Fig. 35

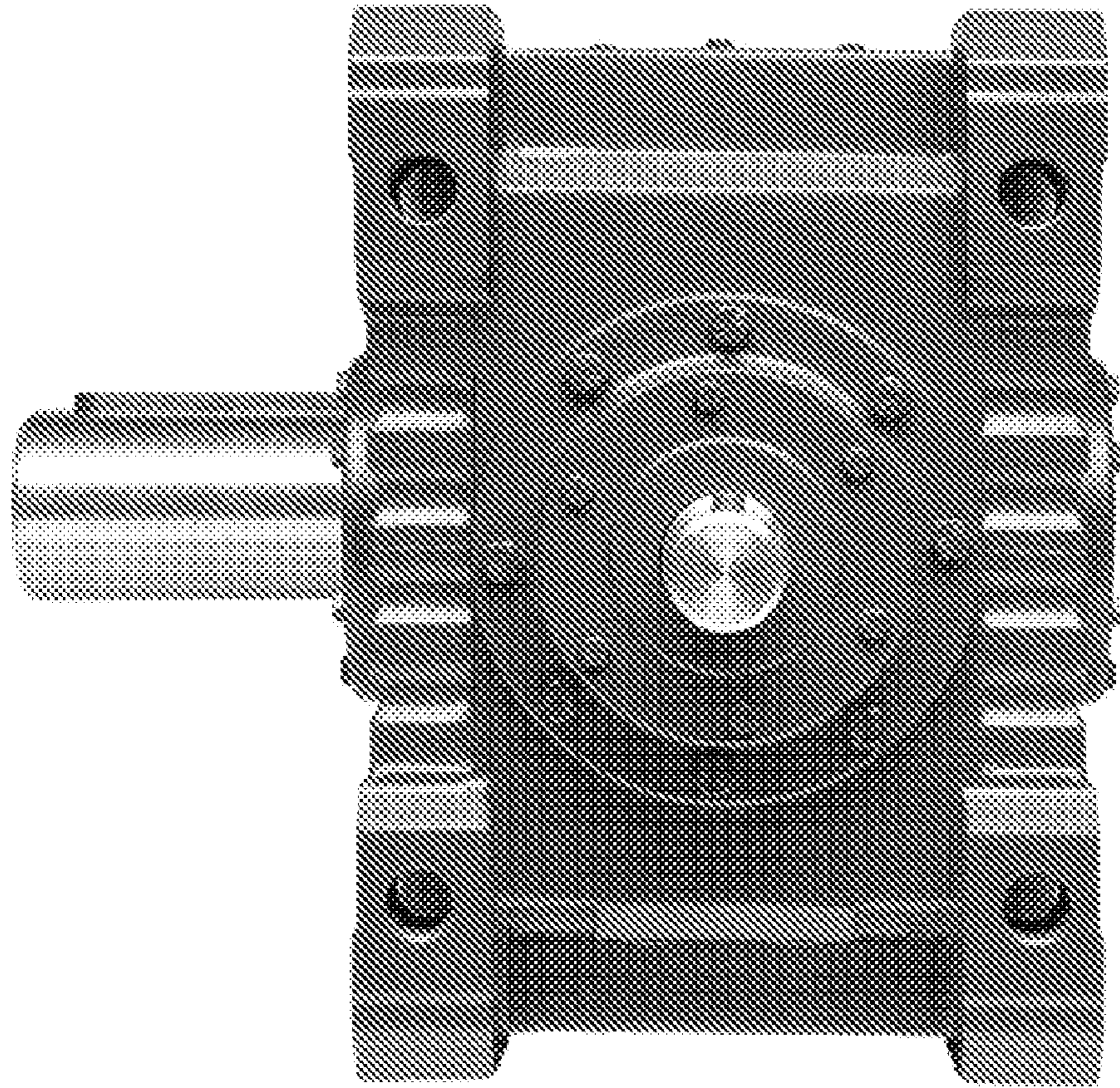

Fig. 36

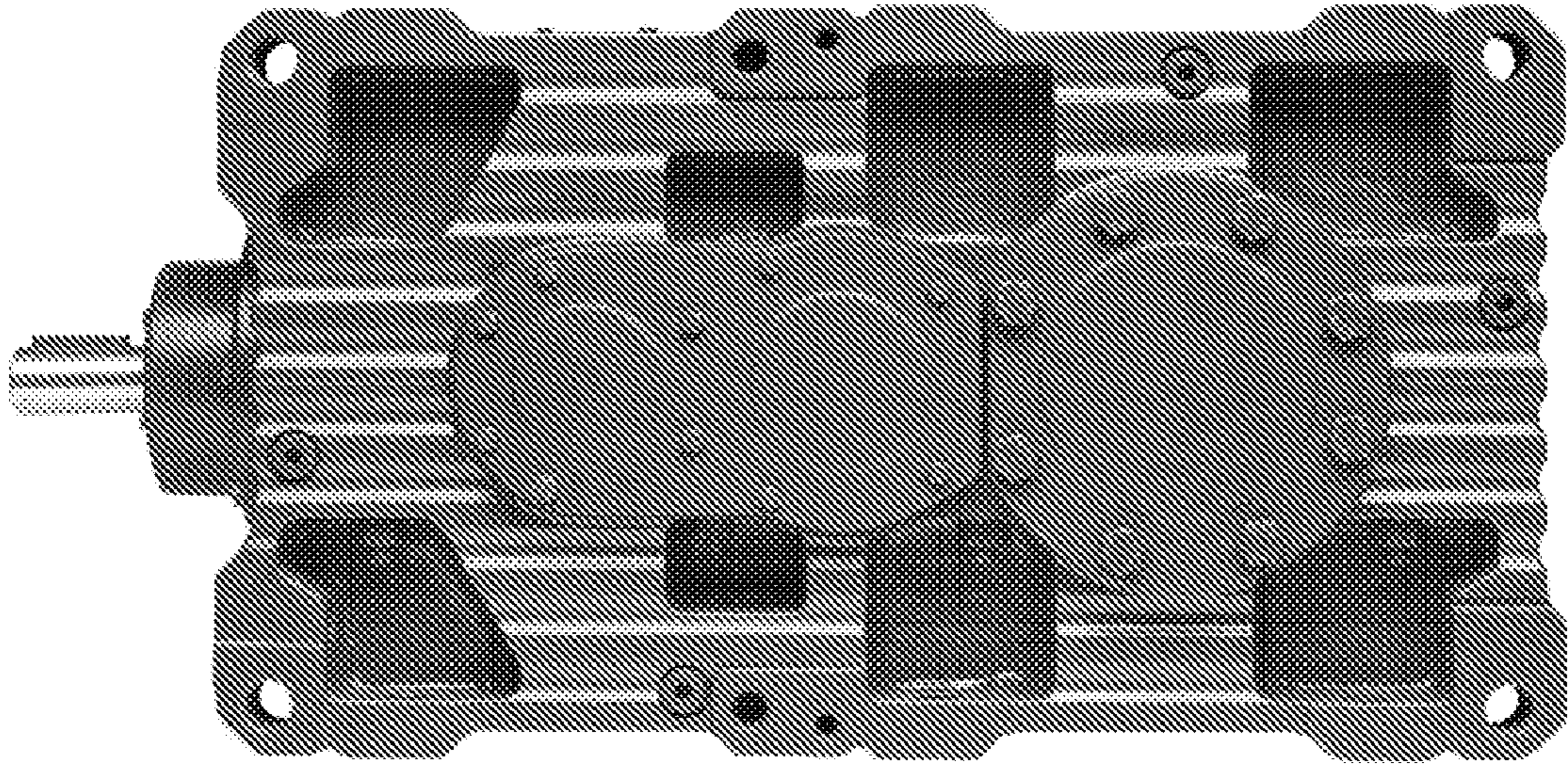

Fig. 37

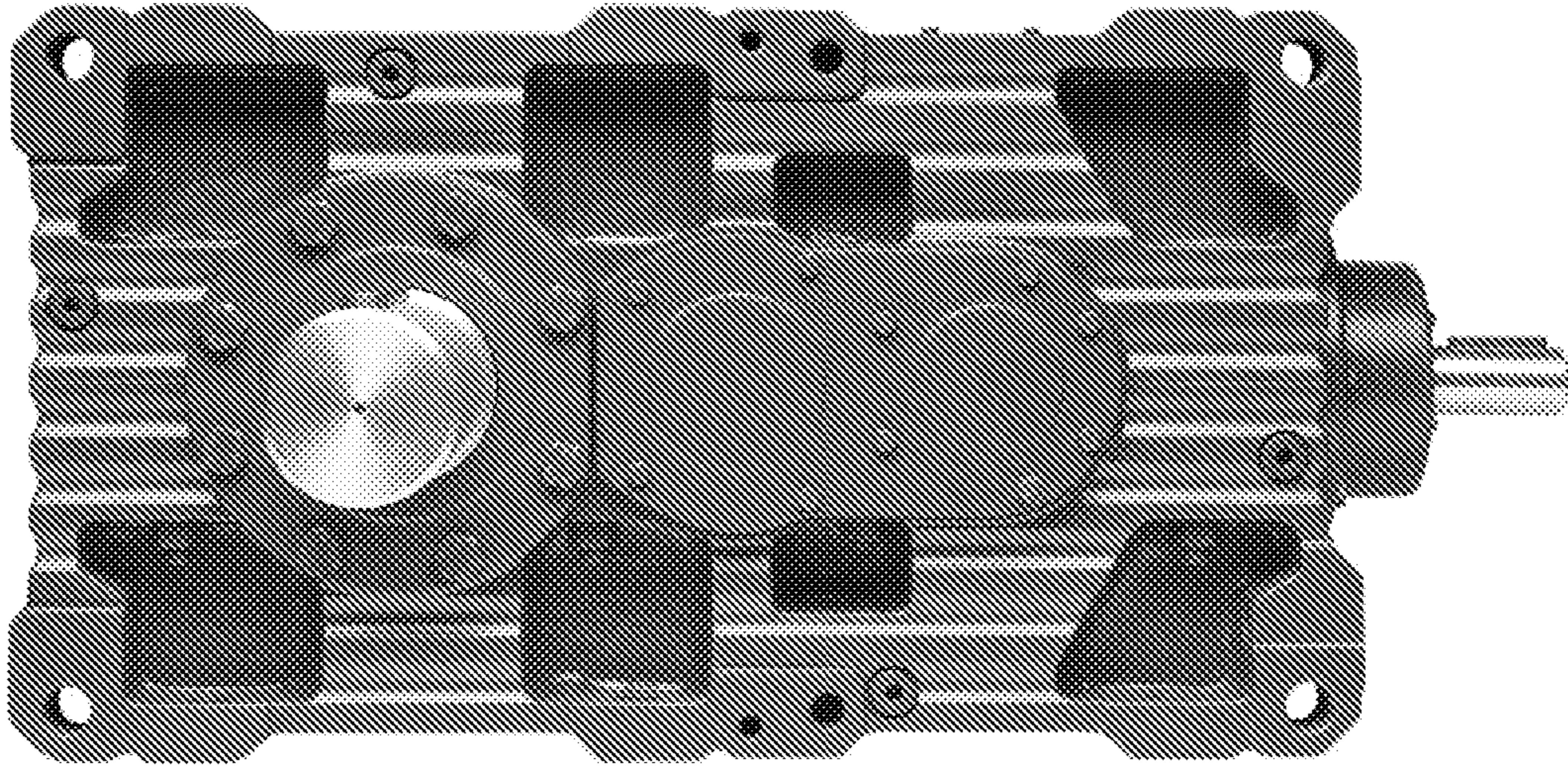

Fig. 38



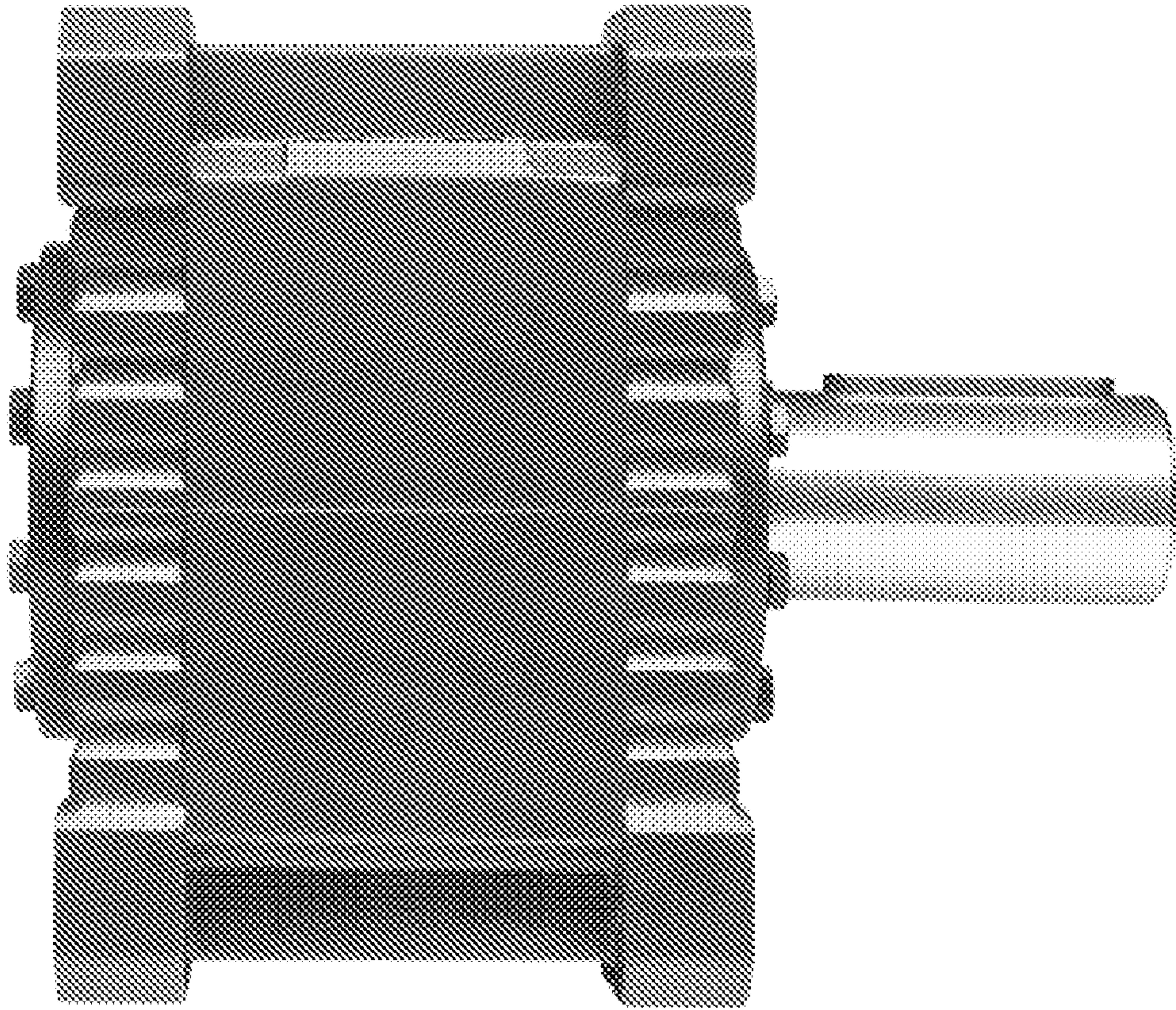

Fig. 39

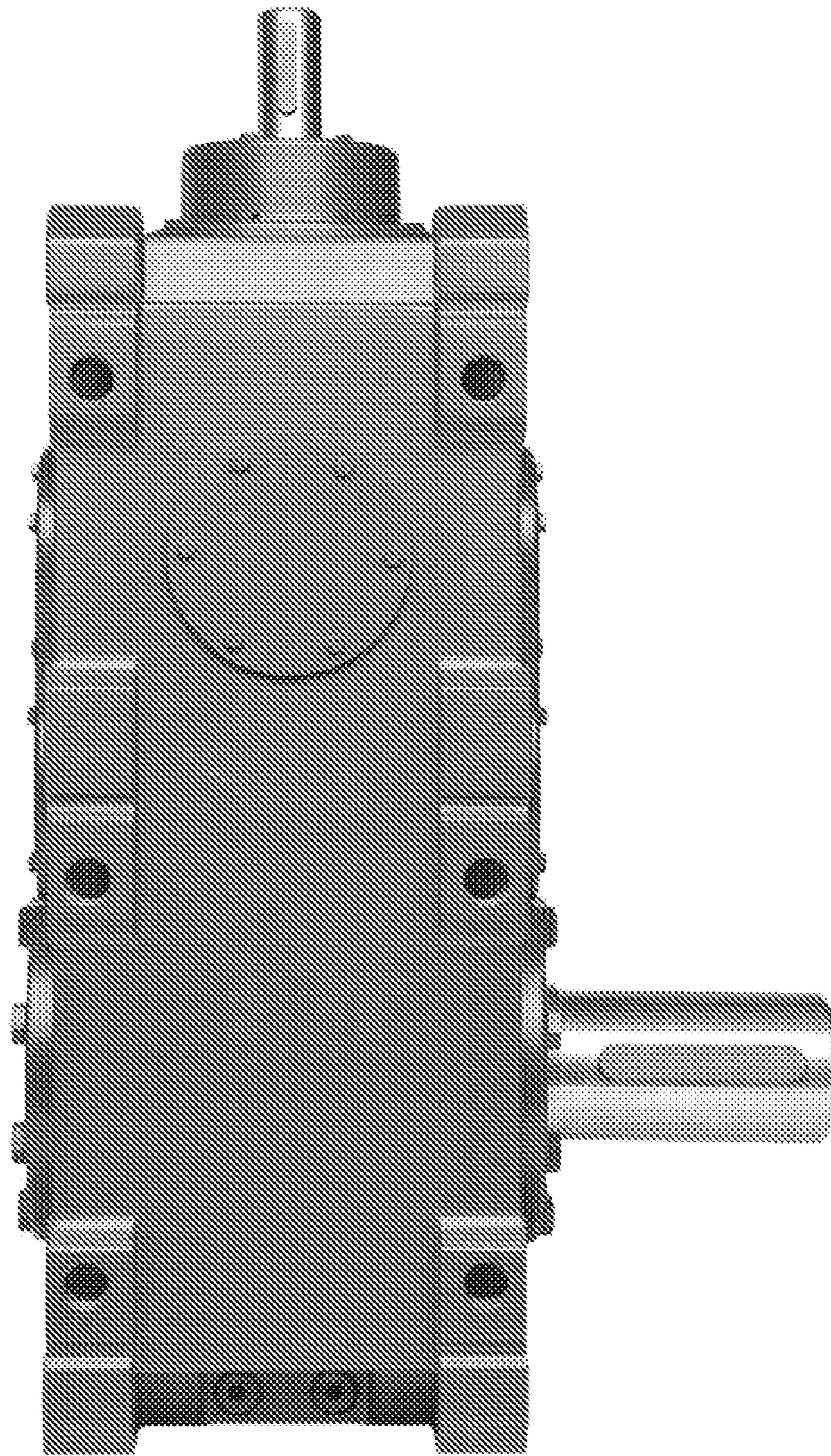

Fig. 40

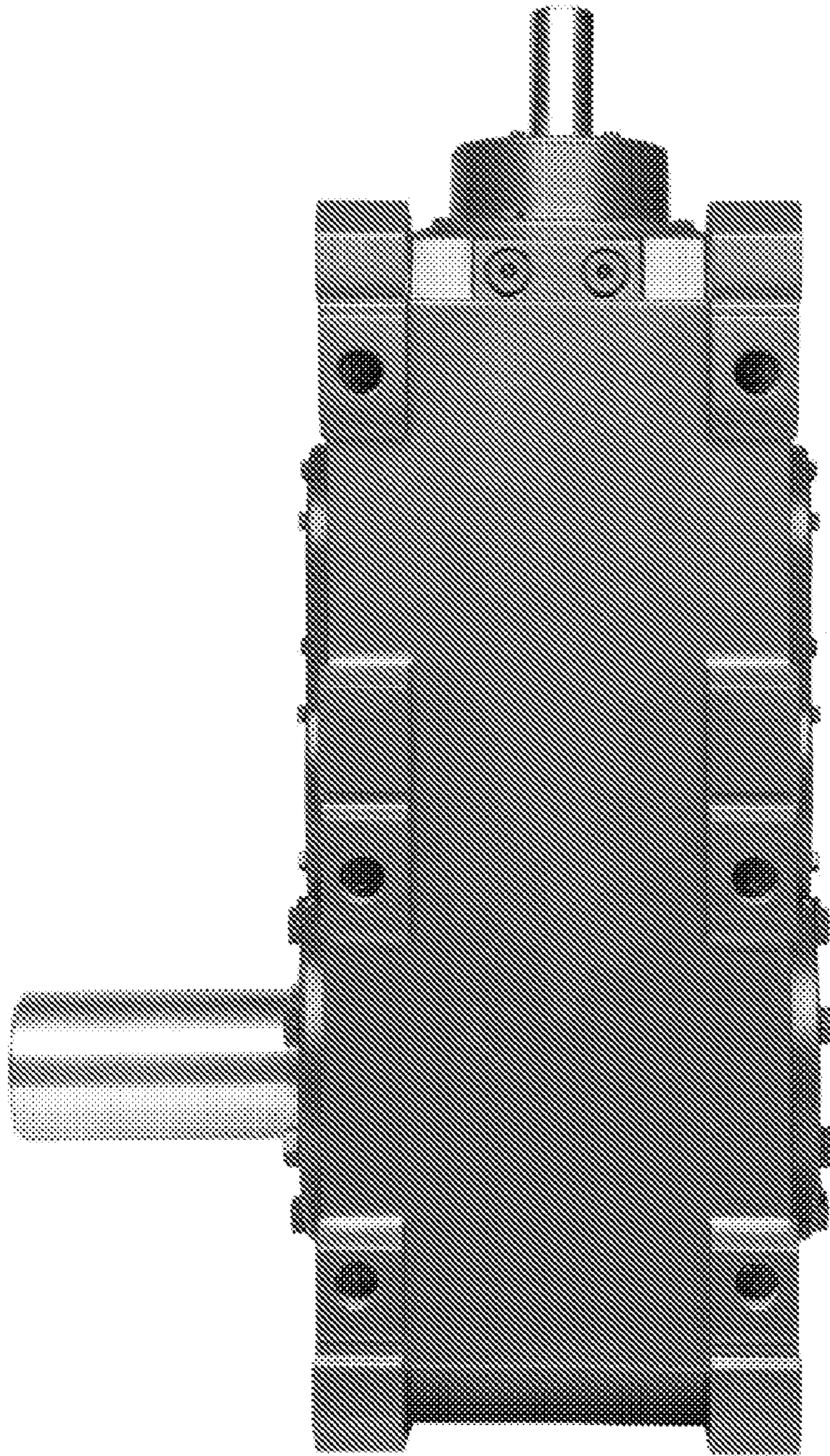

Fig. 41

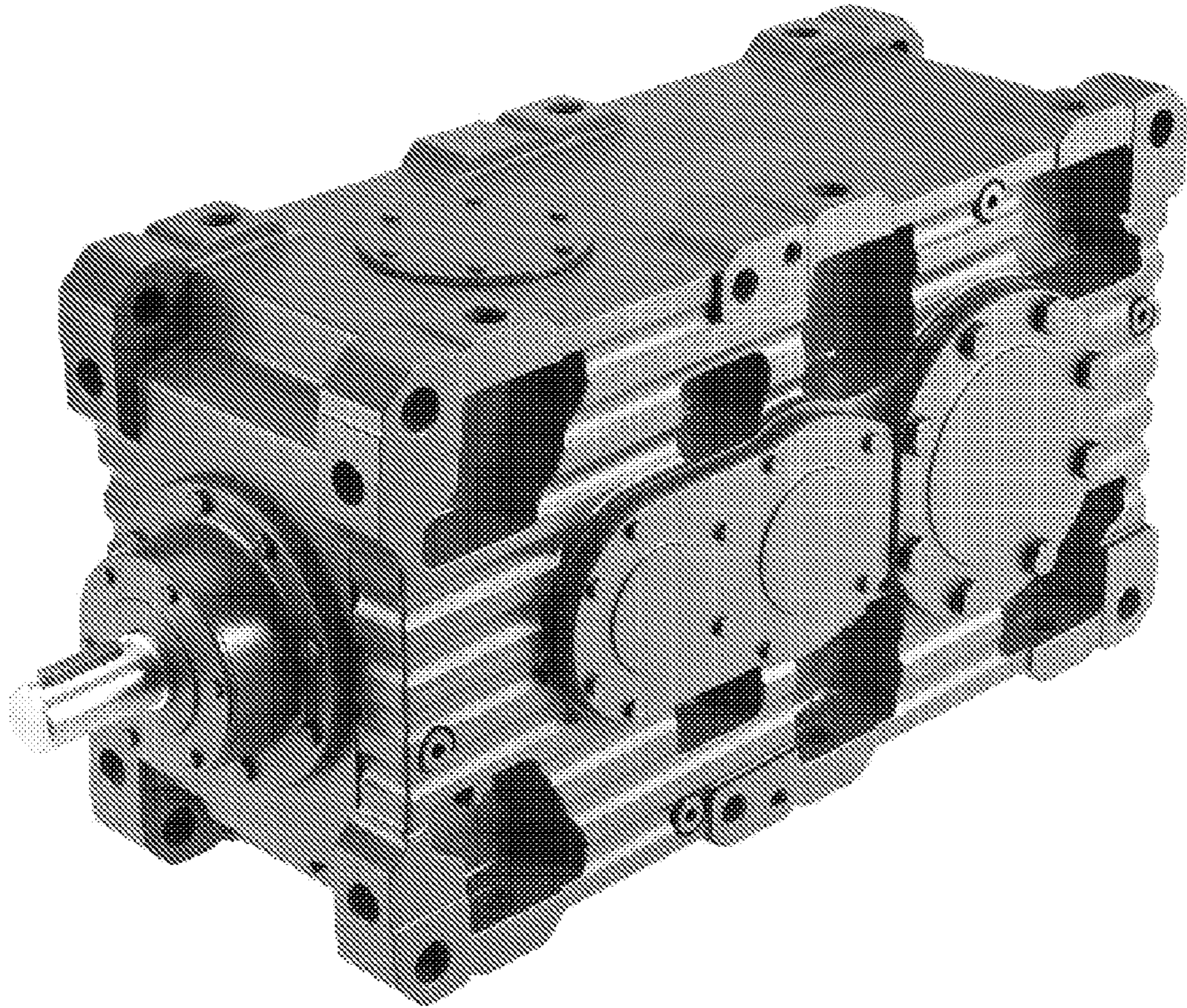

Fig. 42

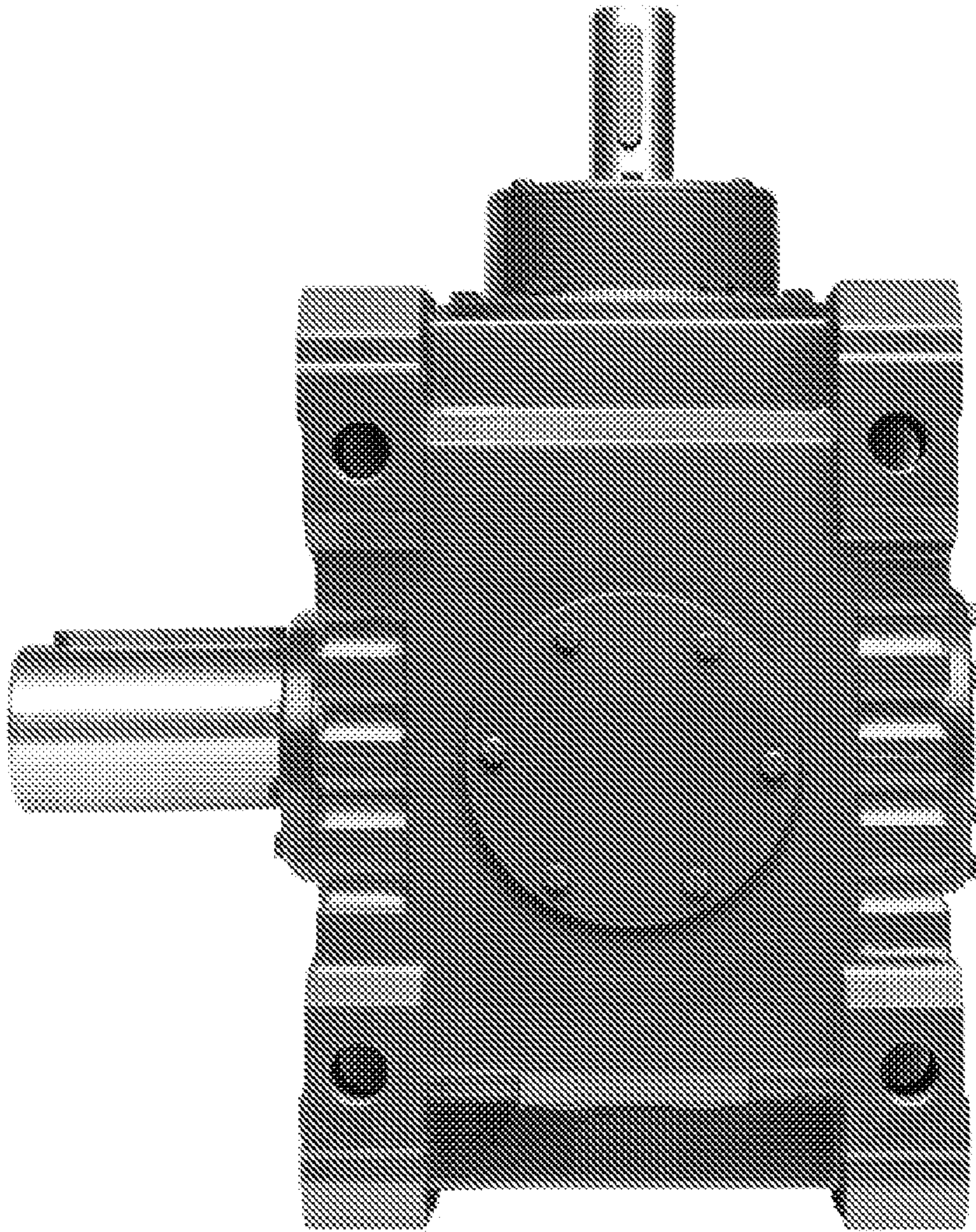

Fig. 43

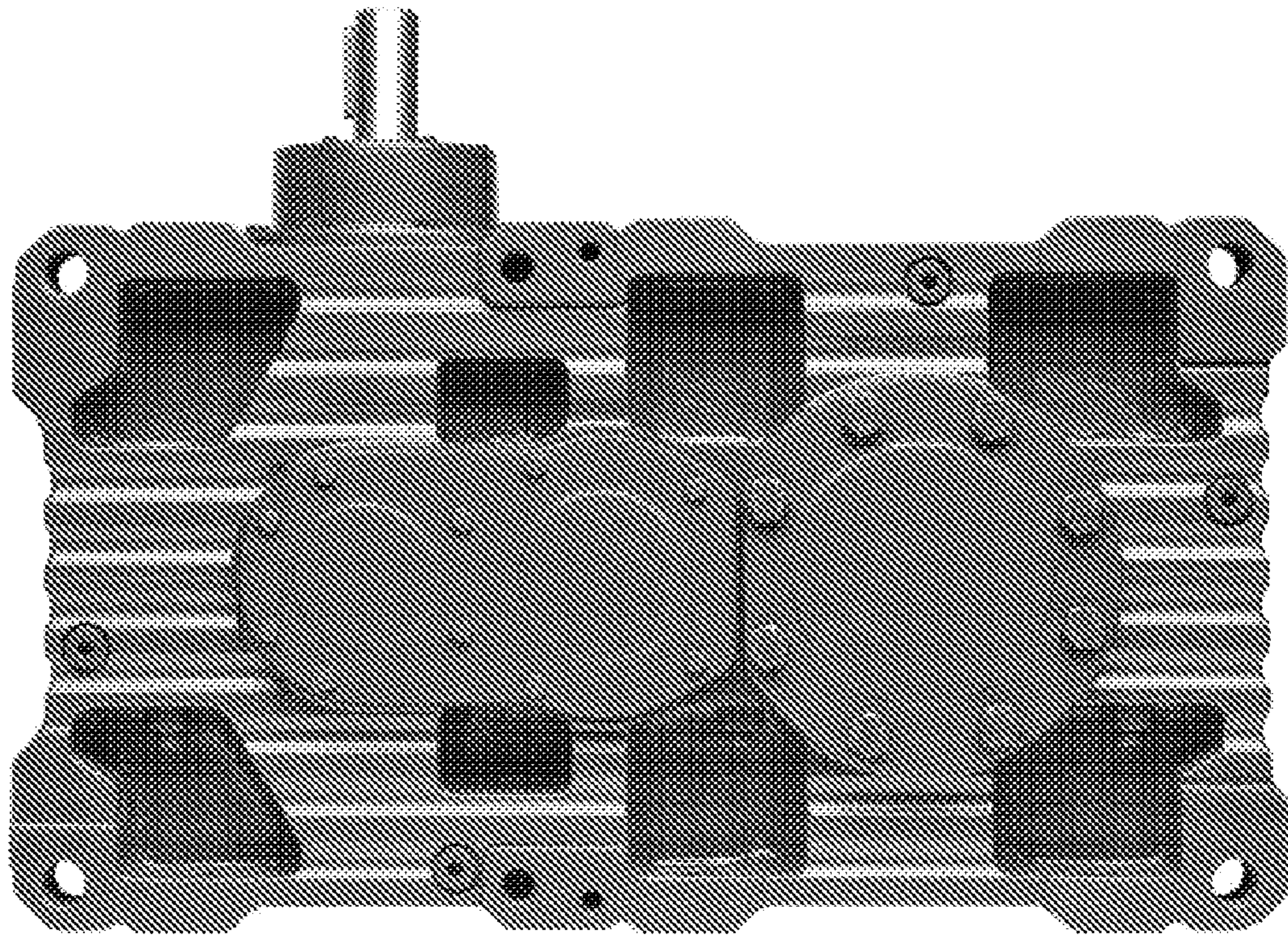

Fig. 44

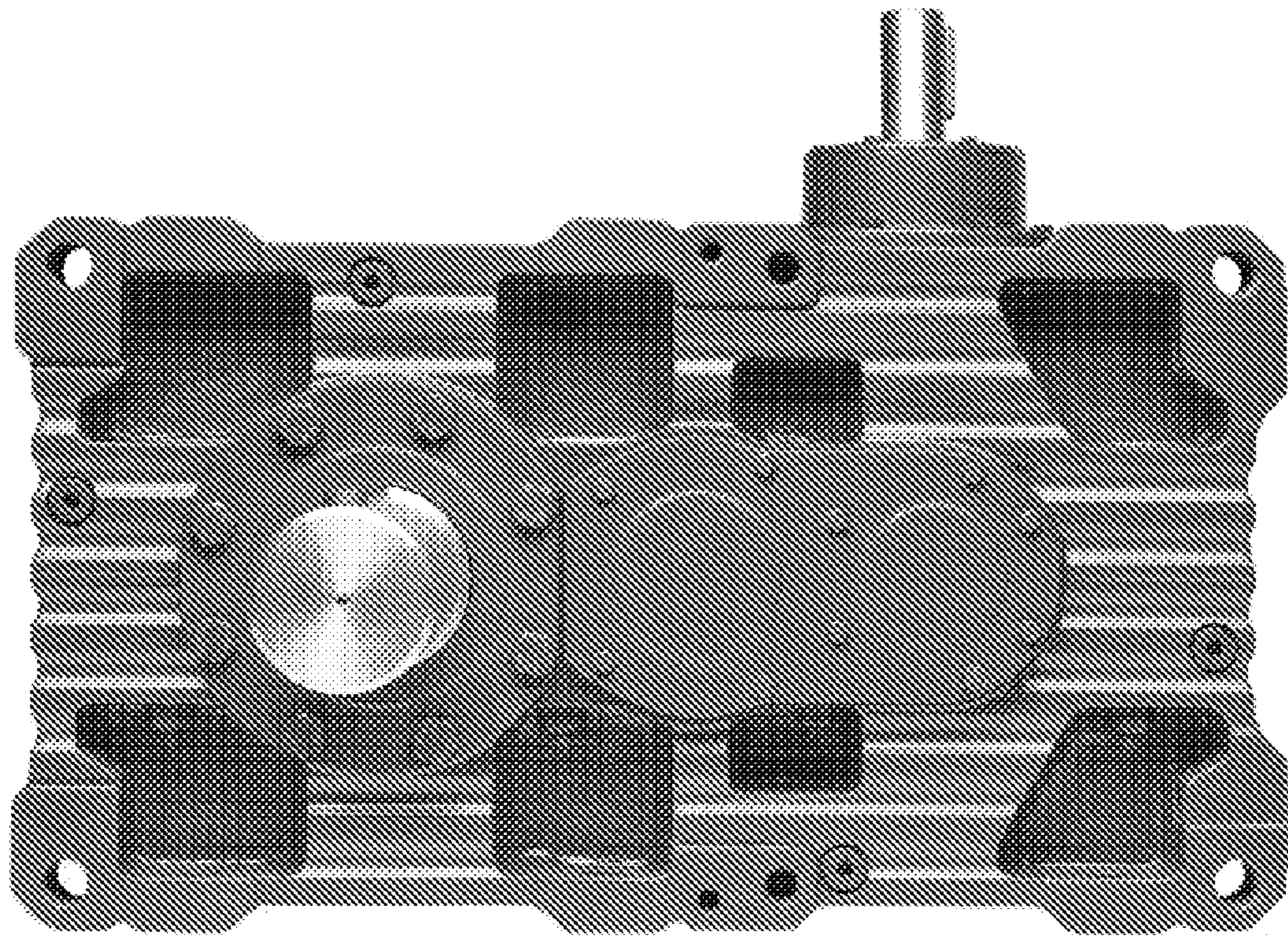

Fig. 45

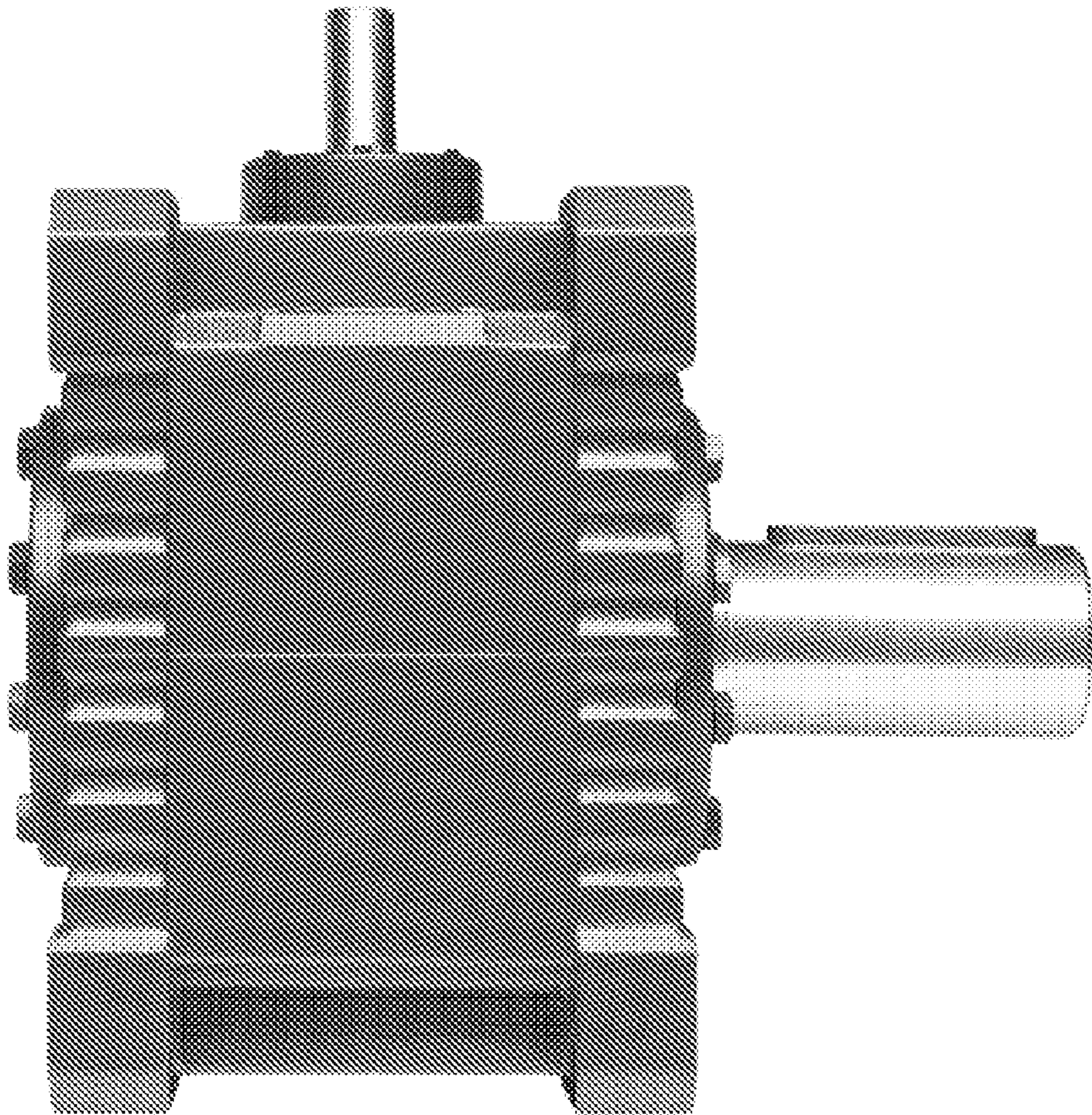

Fig. 46



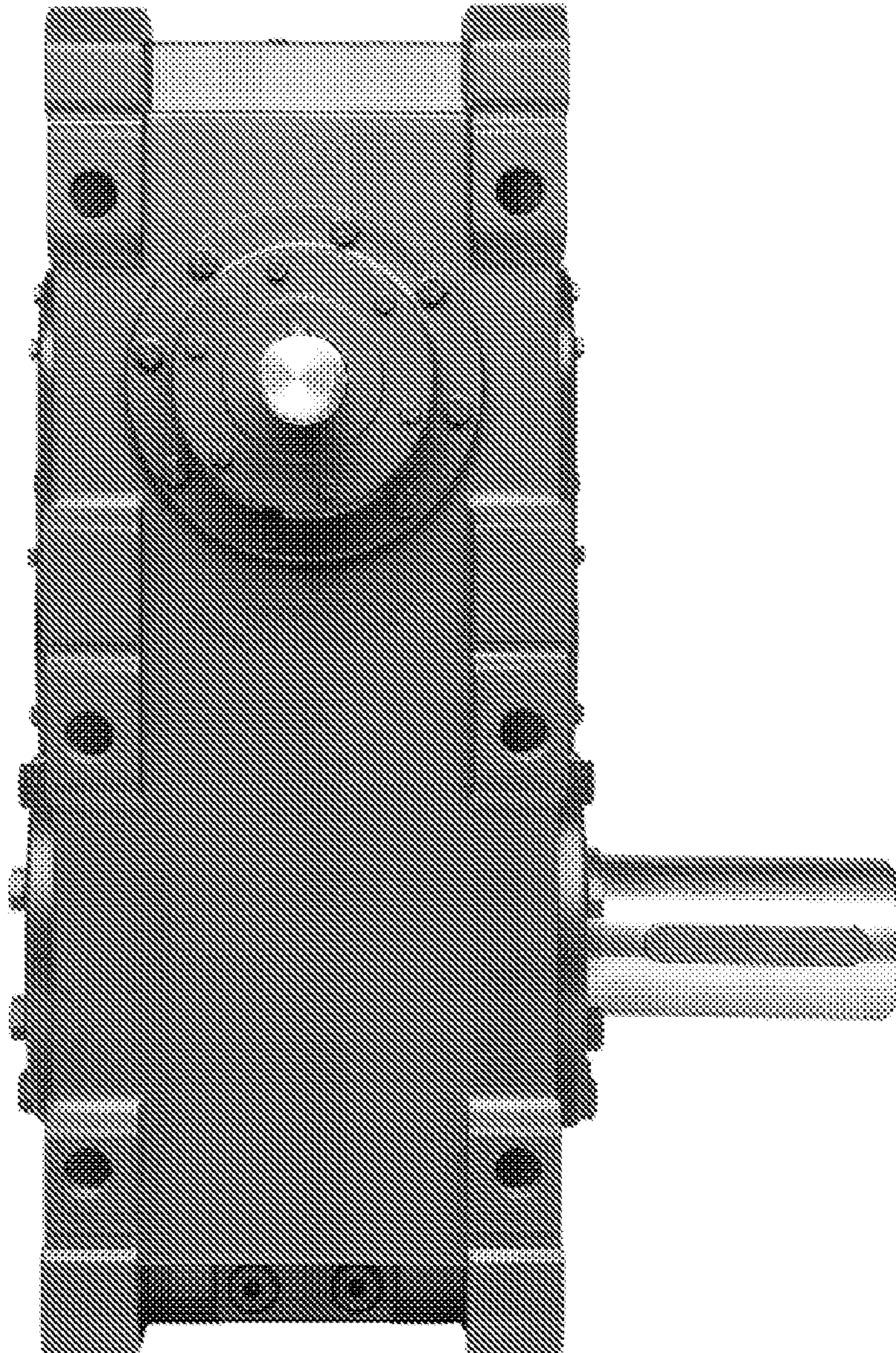

Fig. 47

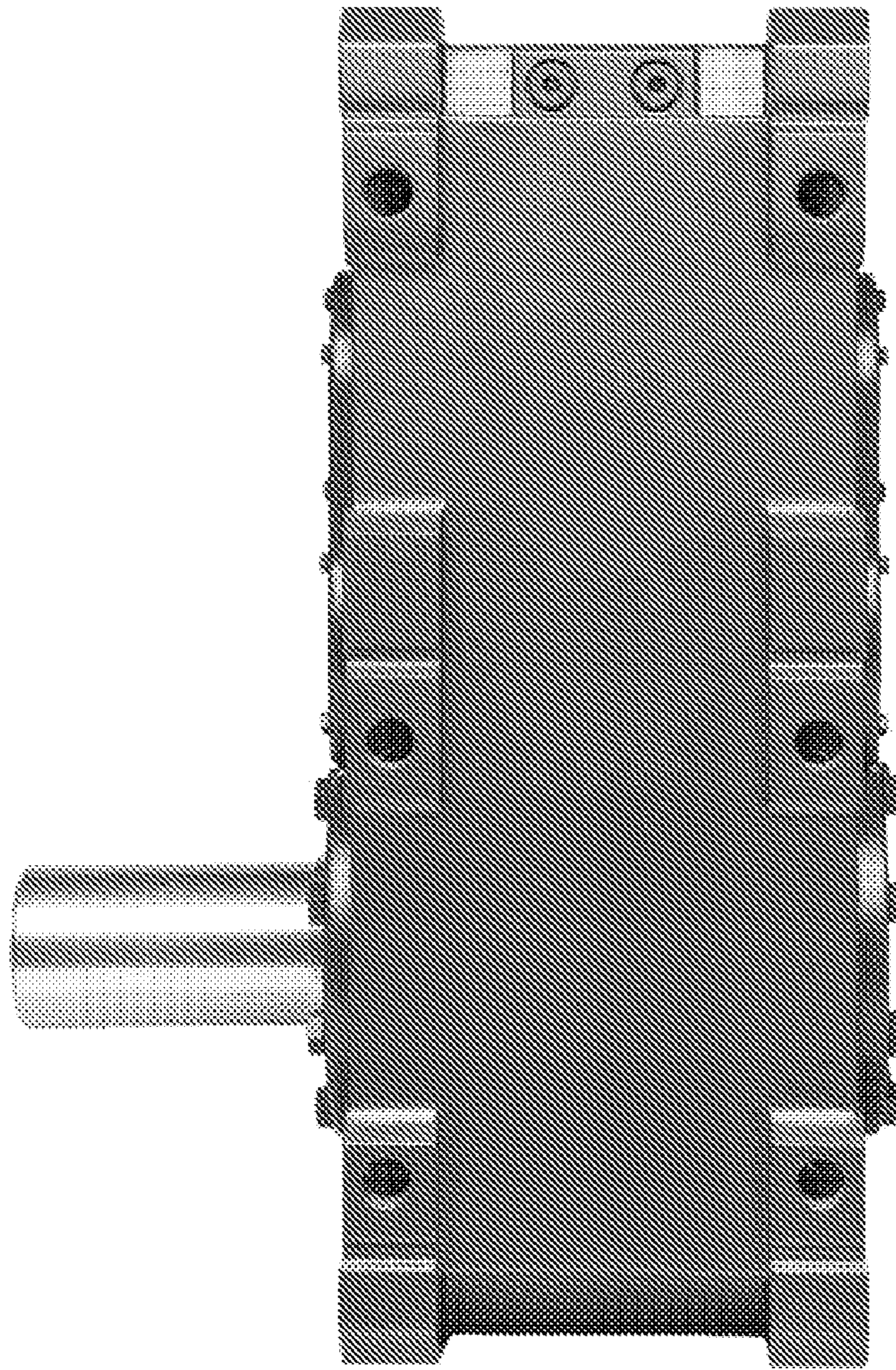

Fig. 48

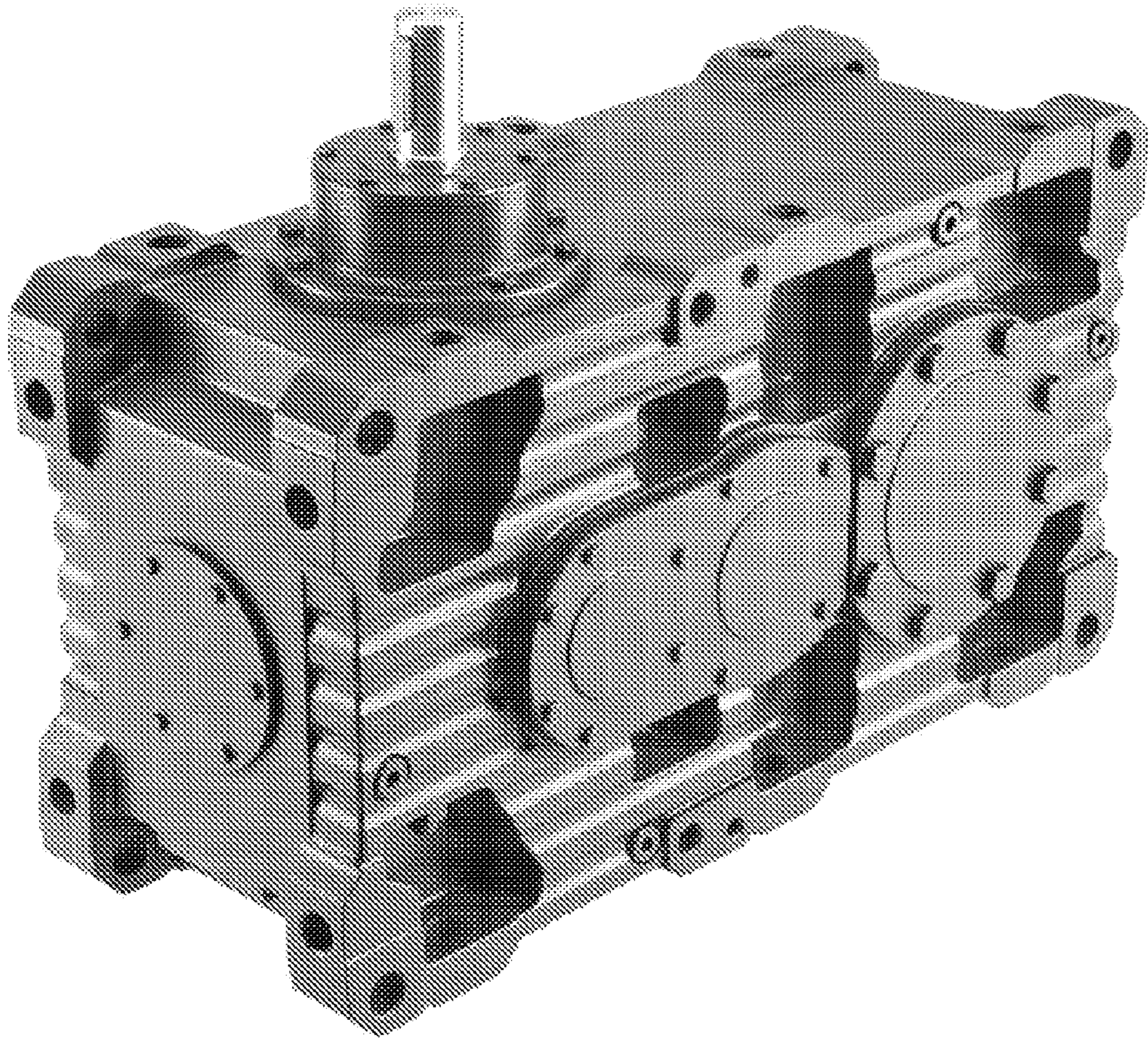

Fig. 49

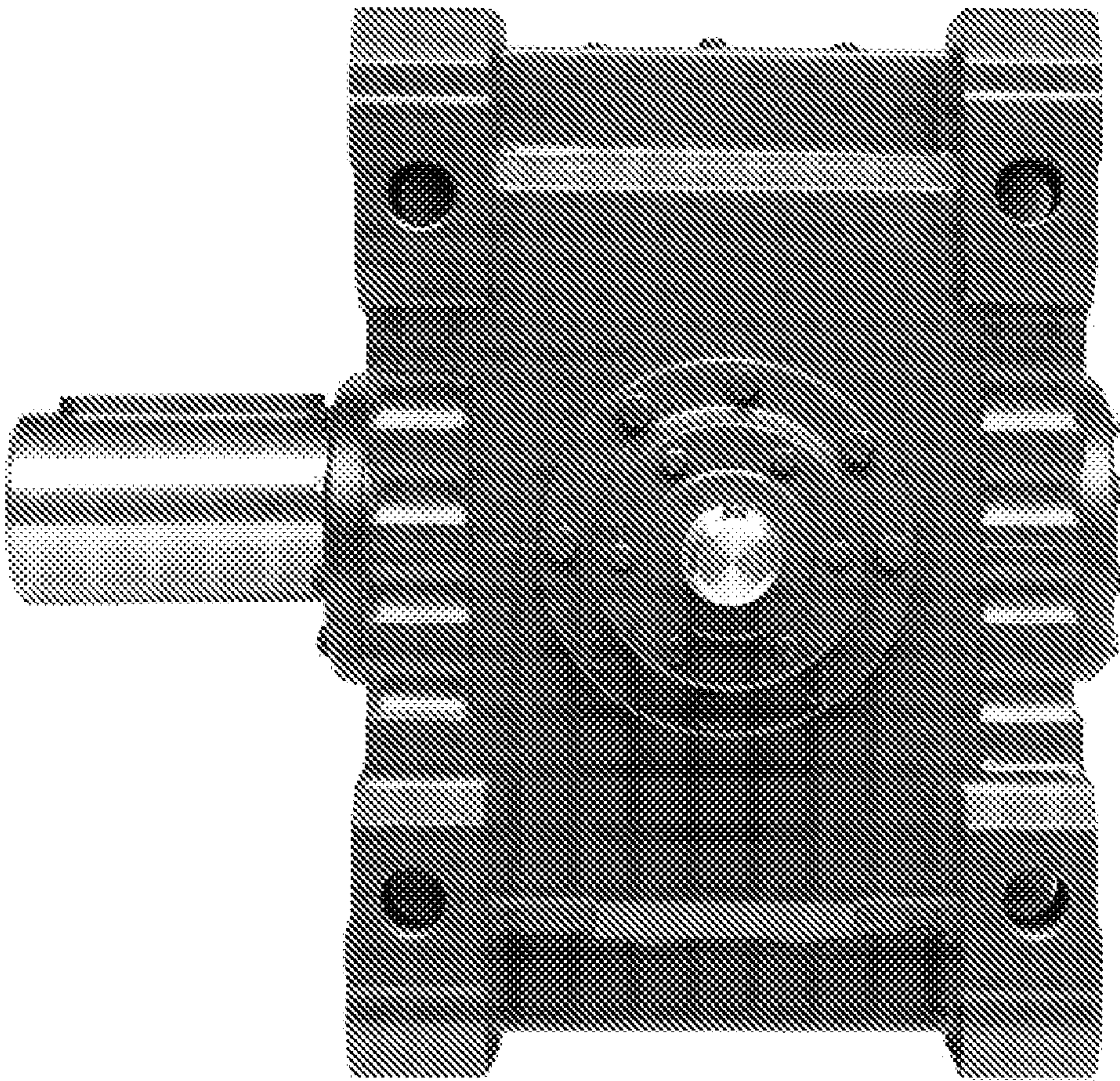

Fig. 50

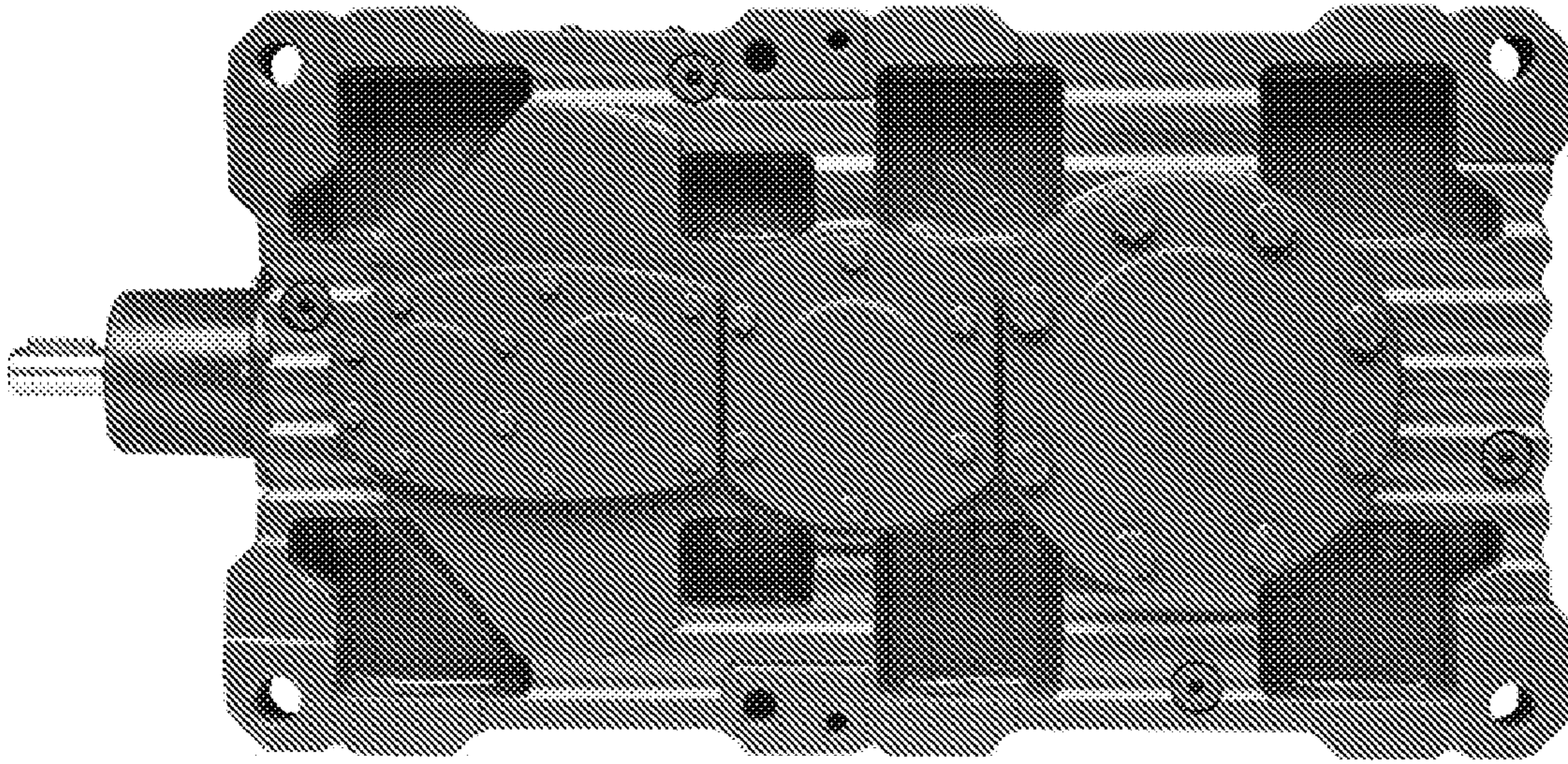

Fig. 51

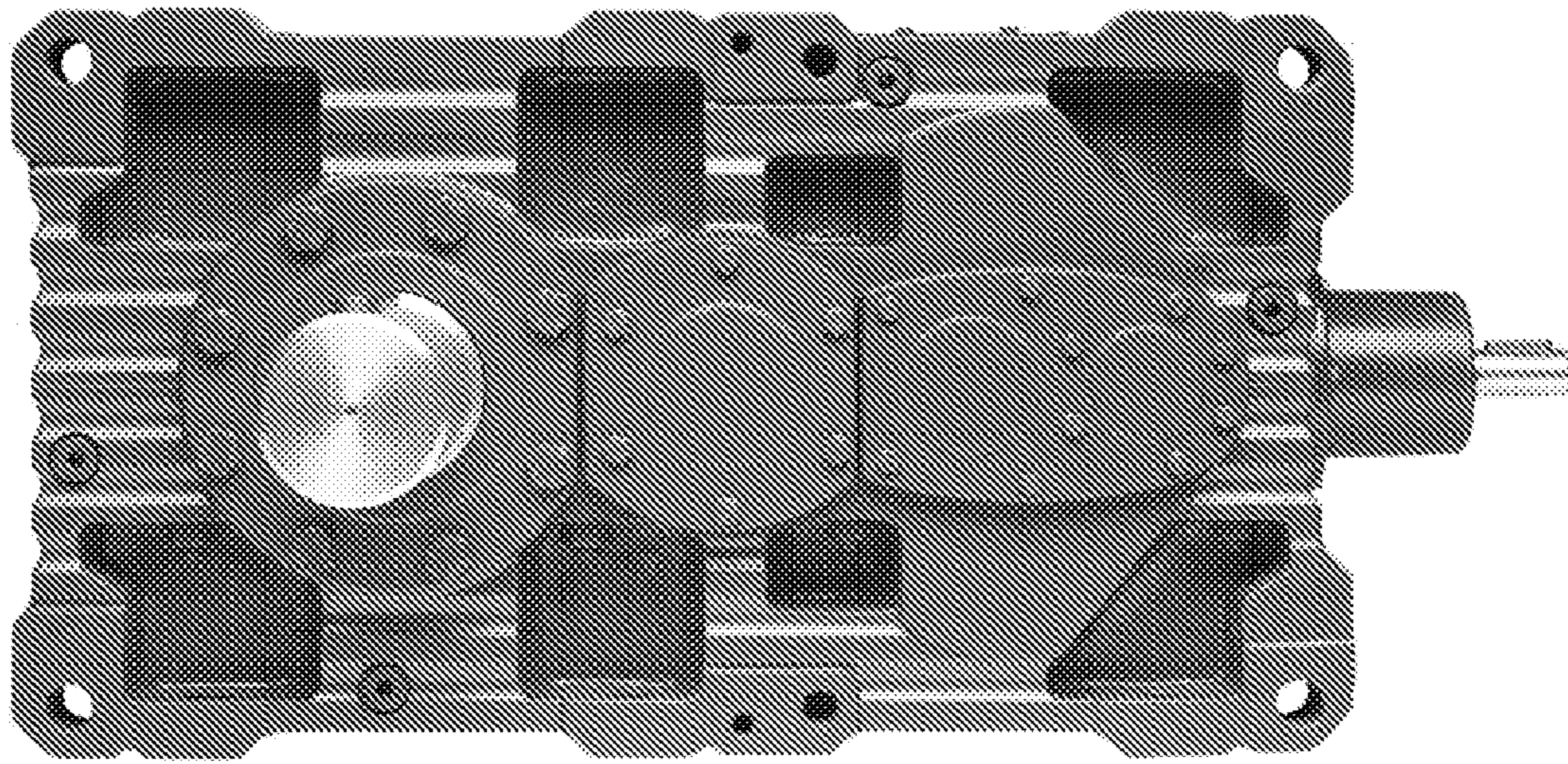

Fig. 52

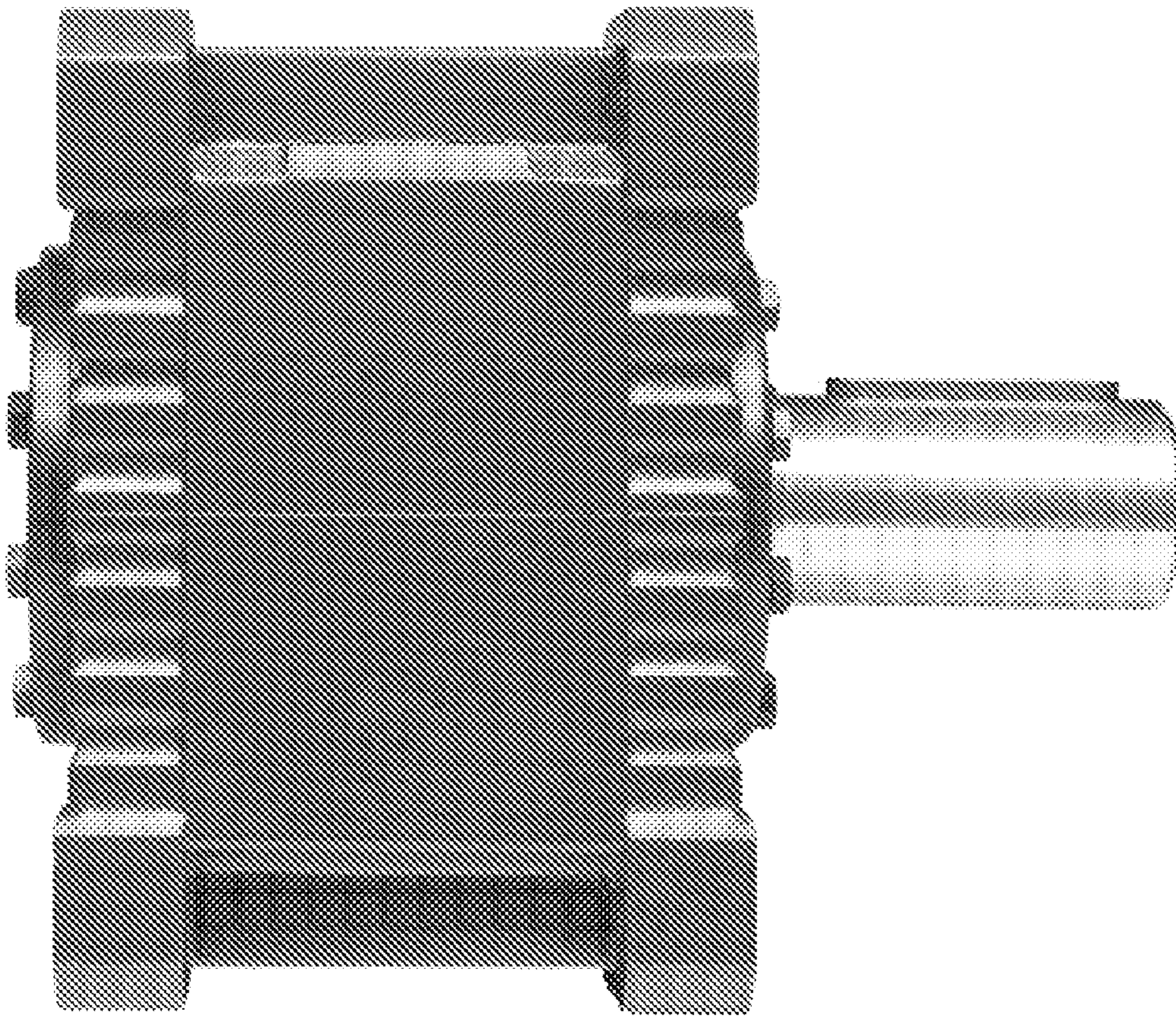

Fig. 53

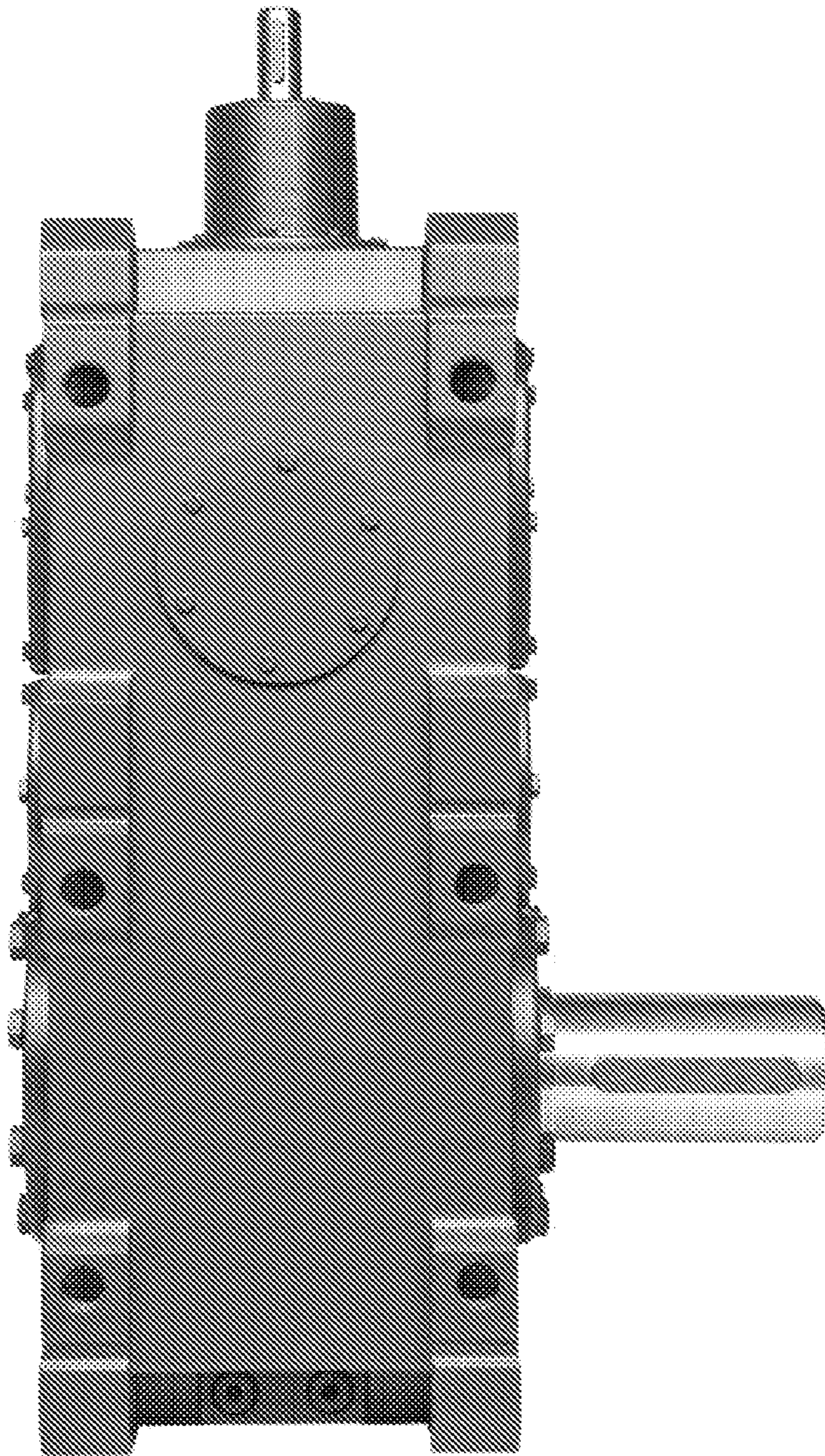

Fig. 54



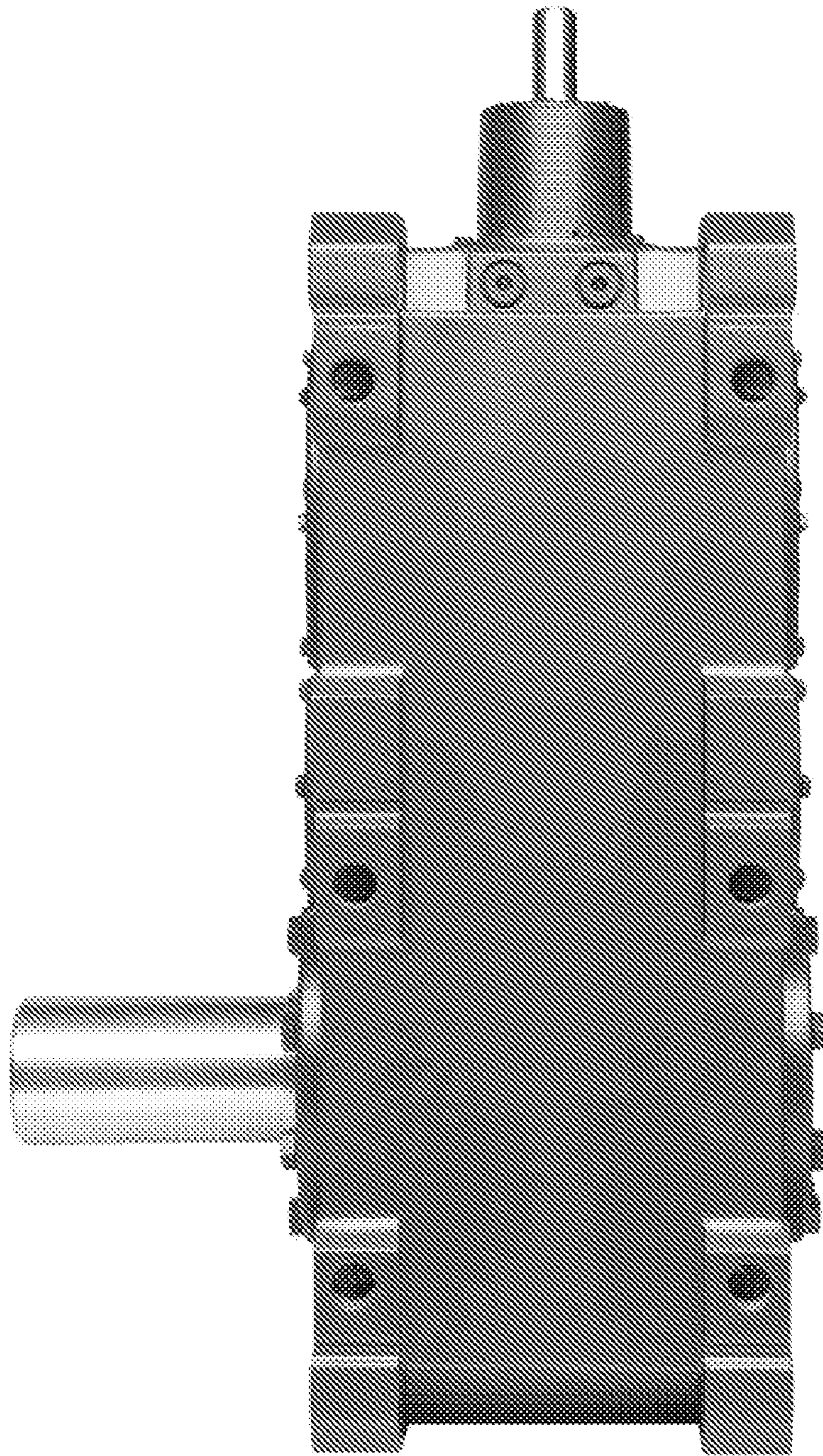

Fig. 55

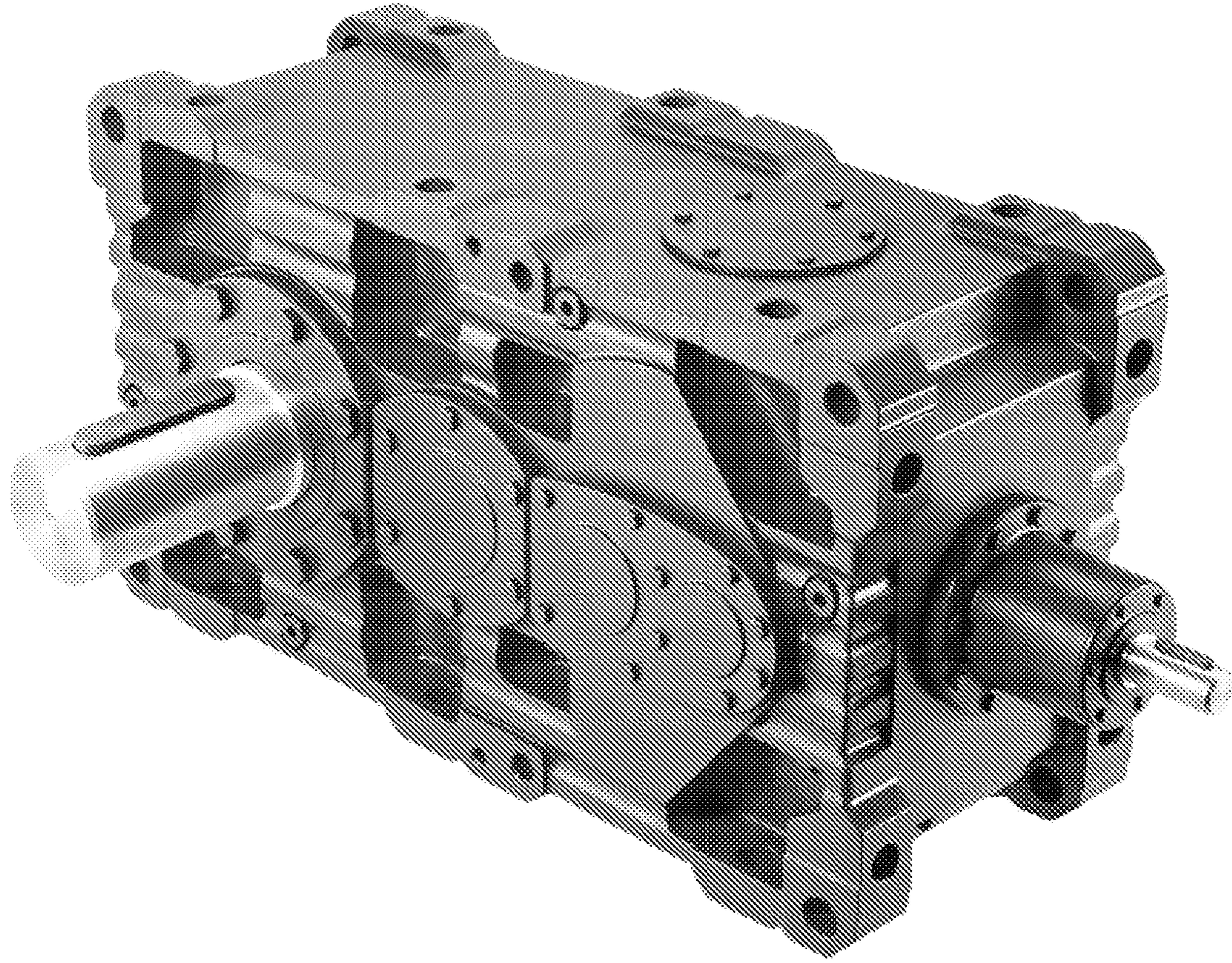

Fig. 56