



US00D571812S

(12) **United States Design Patent**
Chen et al.

(10) **Patent No.:** **US D571,812 S**
(45) **Date of Patent:** **** Jun. 24, 2008**

(54) **COMPUTER FRONT BEZEL**

(75) Inventors: **Yun-Lung Chen**, Taipei Hsien (TW);
Qun Wang, Shenzhen (CN)

(73) Assignee: **Hon Hai Precision Industry Co., Ltd.**,
Tu-Cheng, Taipei Hsien (TW)

(**) Term: **14 Years**

(21) Appl. No.: **29/275,532**

(22) Filed: **Dec. 29, 2006**

(51) **LOC (8) Cl.** **14-02**

(52) **U.S. Cl.** **D14/445**

(58) **Field of Classification Search** D14/441-446;
D13/162, 184, 199; 312/223.1-223.3; 361/680-686,
361/690-696, 725; 369/34.01, 36.01
See application file for complete search history.

(56) **References Cited**

U.S. PATENT DOCUMENTS

D314,568 S *	2/1991	Martin	D14/445
D363,477 S *	10/1995	Tinsley et al.	D14/445
D440,572 S *	4/2001	Jean et al.	D14/445
D474,187 S *	5/2003	Hsu	D14/445
6,671,179 B2 *	12/2003	Chen	361/725

* cited by examiner

Primary Examiner—Freda S Nunn
(74) *Attorney, Agent, or Firm*—Wei Te Chung

(57) **CLAIM**

The ornamental design for a computer front bezel, as shown and described.

DESCRIPTION

FIG. 1 is a perspective view of the design for the computer front bezel wherein broken lines illustrate environmental features;

FIG. 2 is a front elevational view thereof;

FIG. 3 is a left side elevational view thereof;

FIG. 4 is a right side elevational view thereof;

FIG. 5 is a top plan view thereof;

FIG. 6 is a bottom plan view thereof; and,

FIG. 7 is a perspective view thereof being mounted to a computer case which is shown in broken lines for illustrative purposes only and forms no part of the claimed design.

In these drawings the solid lines illustrate the claimed ornamental design whereas the broken lines illustrate environmental features that form no part of the claimed ornamental design.

1 Claim, 7 Drawing Sheets

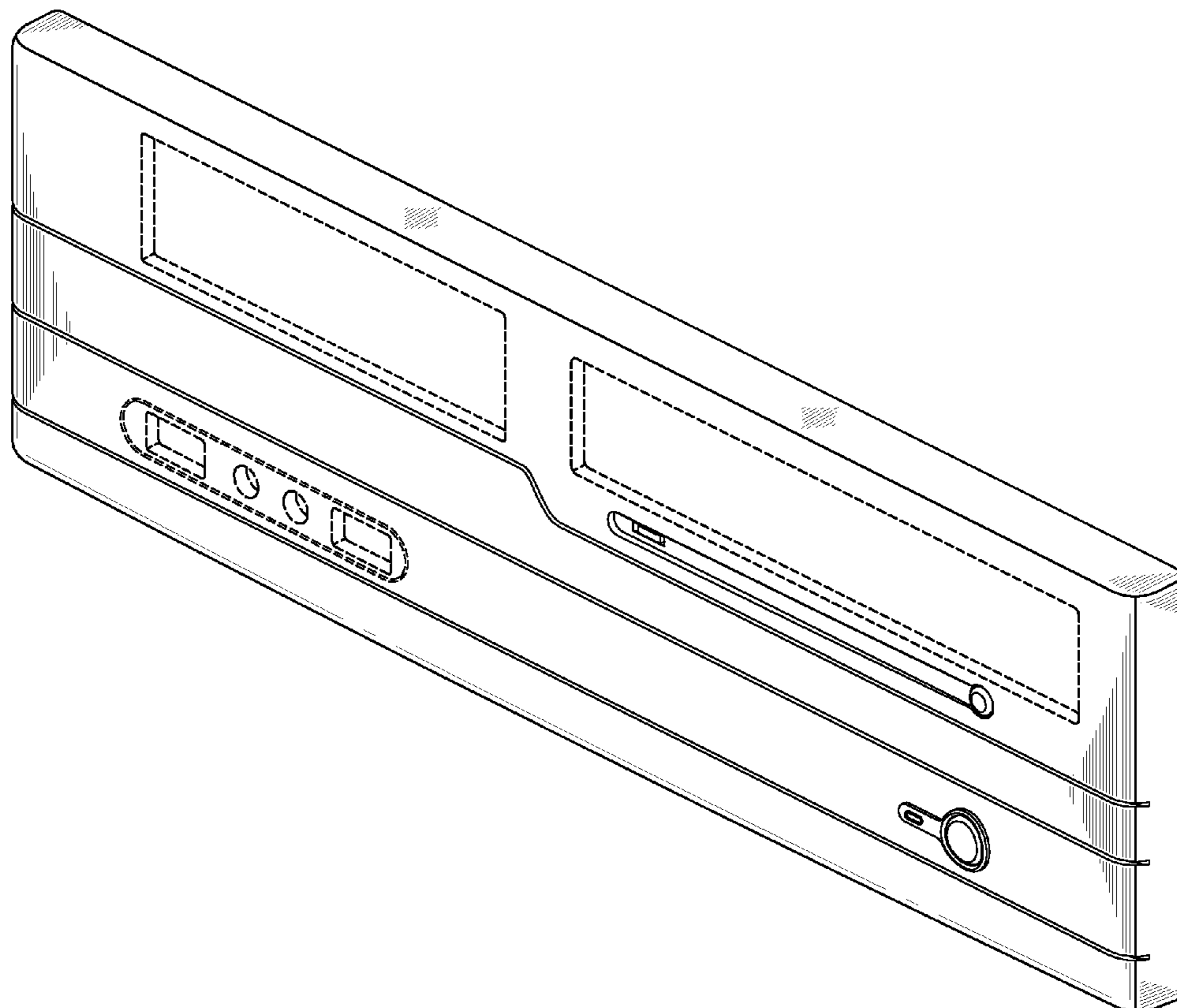

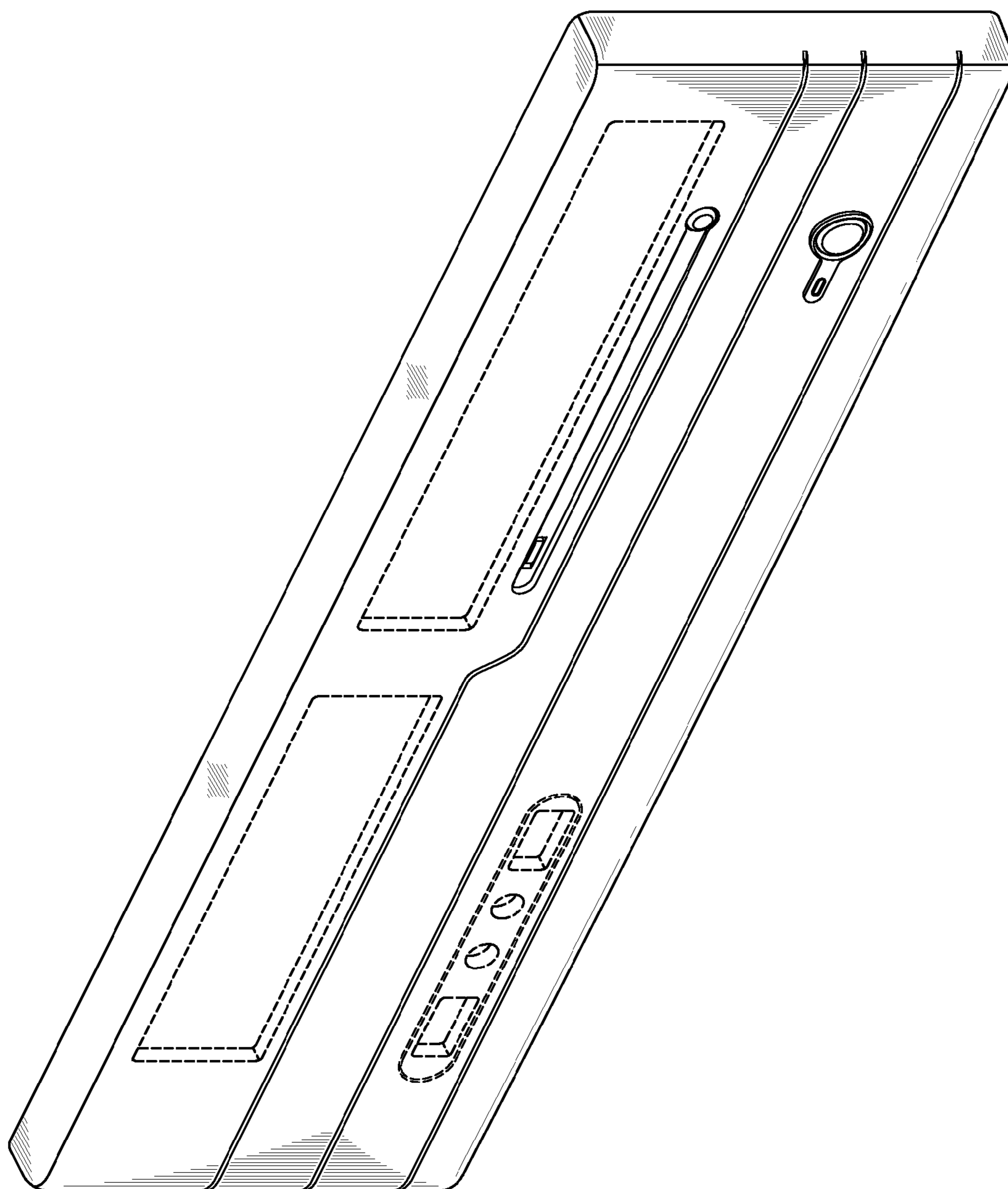

FIG. 1

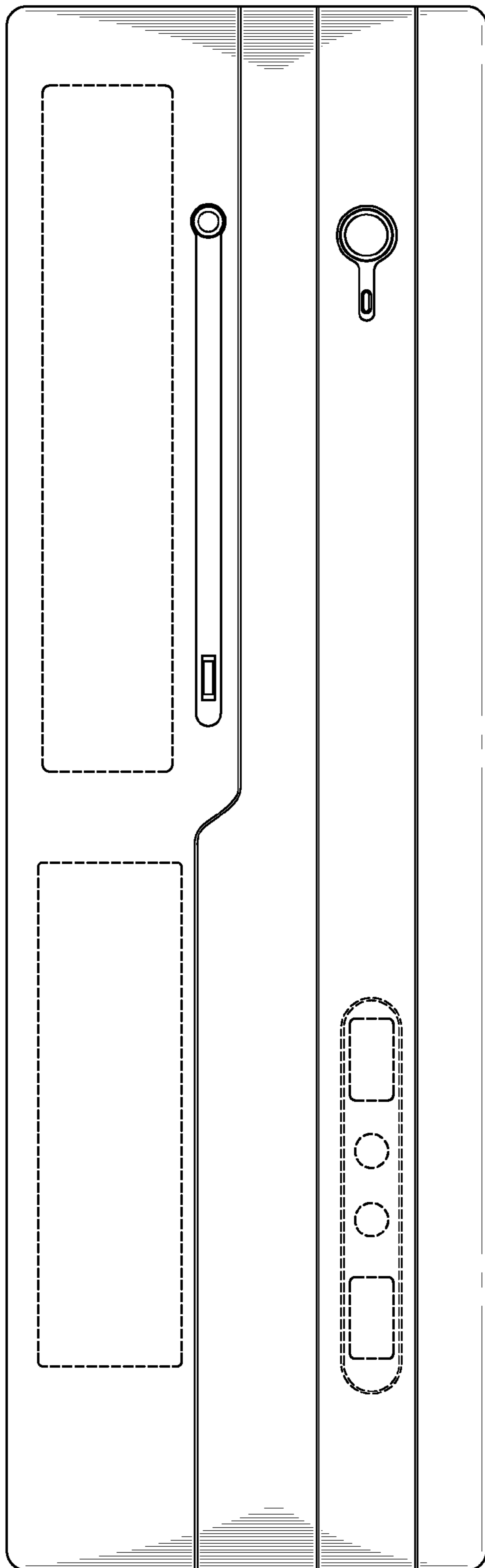

FIG. 2



FIG. 3

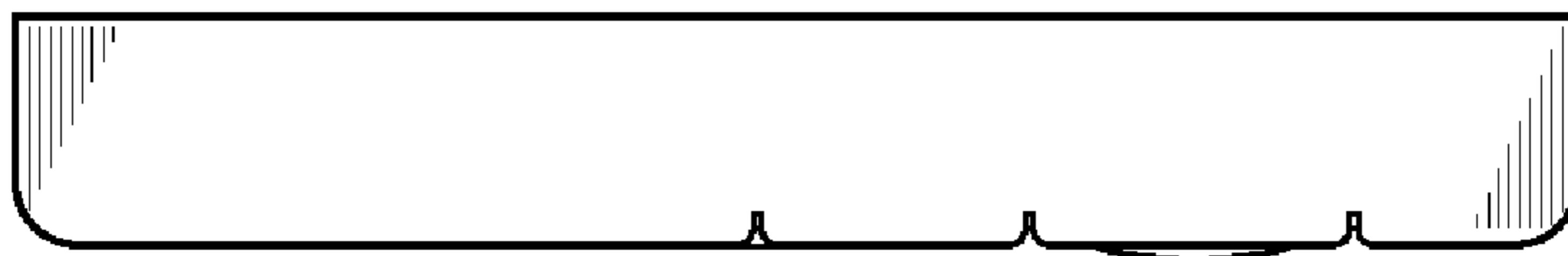

FIG. 4

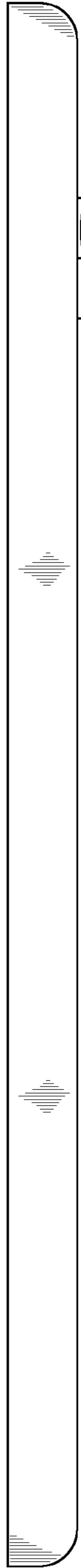

FIG. 5



FIG. 6

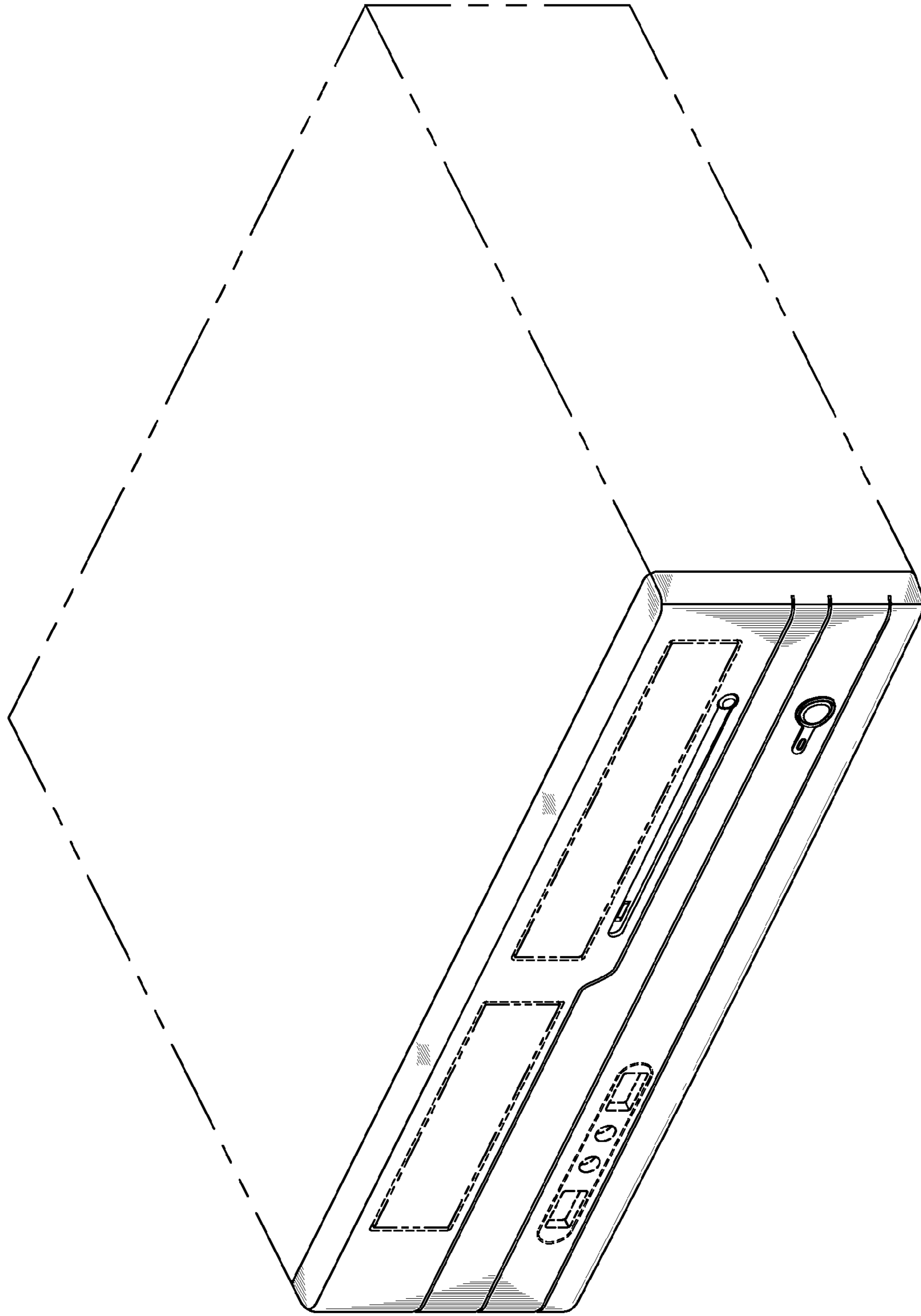

FIG. 7