



US00D571700S

(12) **United States Design Patent**  
**Laurent et al.**

(10) **Patent No.:** **US D571,700 S**  
(45) **Date of Patent:** **\*\* Jun. 24, 2008**

(54) **INTEGRATED LIGHT AND VISOR CONTROL FOR AN AUTOMOBILE**

6,938,942 B1 \* 9/2005 Ytterberg ..... 296/97.9  
D539,714 S \* 4/2007 Toyama et al. .... D12/192

(76) Inventors: **Patrice Laurent**, N. 183 allée de la Thyollire, Bâtiment A, appartement Ao3, Residence le Clos Vully, 74250 Viuz en Sallaz (FR); **Jean-Marc Tissot**, Le Bellevue, Le Bourg, 74250 Viuz en Sallaz (FR); **Stephane Vanhelle**, 50 rue Croix du Martelet, 74970 Marignier (FR)

\* cited by examiner

*Primary Examiner*—Caron D. Veynar  
*Assistant Examiner*—Abraham Bahta  
(74) *Attorney, Agent, or Firm*—Sofer & Haroun, LLP

(\*\*) Term: **14 Years**

(57) **CLAIM**

We claim the ornamental design for an integrated light and visor control for an automobile, as shown and described.

(21) Appl. No.: **29/224,373**

**DESCRIPTION**

(22) Filed: **Feb. 28, 2005**

FIG. 1 is a bottom perspective view of an integrated light and visor control showing our new design;

(30) **Foreign Application Priority Data**

Sep. 6, 2004 (FR) ..... 044270

FIG. 2 is a left side view of the integrated light and visor control from FIG. 1;

(51) **LOC (8) Cl.** ..... **12-16**

(52) **U.S. Cl.** ..... **D12/192**

(58) **Field of Classification Search** ..... D12/190–192, D12/345, 418, 187, 188; 296/190.03, 97.1, 296/97.2, 97.3, 97.7, 97.9, 190.01, 70, 1.07, 296/1.11; 280/750–751; 180/90; 362/490, 362/494; D26/28

FIG. 3 is a rear view of the integrated light and visor control from FIG. 1;

FIG. 4 is a front view of the integrated light and visor control from FIG. 1;

See application file for complete search history.

FIG. 5 is a bottom side perspective view of the integrated light and visor control from FIG. 1 shown attached to a car roof and windshield;

FIG. 6 is a bottom front perspective view of the integrated light and visor control from FIG. 1 shown attached to a car roof and windshield;

(56) **References Cited**

**U.S. PATENT DOCUMENTS**

4,133,405 A \* 1/1979 Turek ..... 180/90  
5,975,708 A \* 11/1999 Fitzpatrick et al. .... 359/844  
D421,946 S \* 3/2000 Drone ..... D12/190  
6,406,086 B2 \* 6/2002 Bauer et al. .... 296/97.4  
D466,061 S \* 11/2002 Samora, Jr. .... D12/191  
6,513,855 B2 \* 2/2003 Zenisek ..... 296/97.9  
6,692,060 B1 \* 2/2004 Wilson ..... 296/97.5  
6,921,121 B2 \* 7/2005 Schneider et al. .... 296/97.1

FIG. 7 is a bottom view of the integrated light and visor control from FIG. 1 shown attached to a car roof and windshield; and,

FIG. 8 is a bottom view of the integrated light and visor control from FIG. 1.

The broken lines shown in the drawing are for illustrative purposes only and form no part of the claimed design.

**1 Claim, 8 Drawing Sheets**

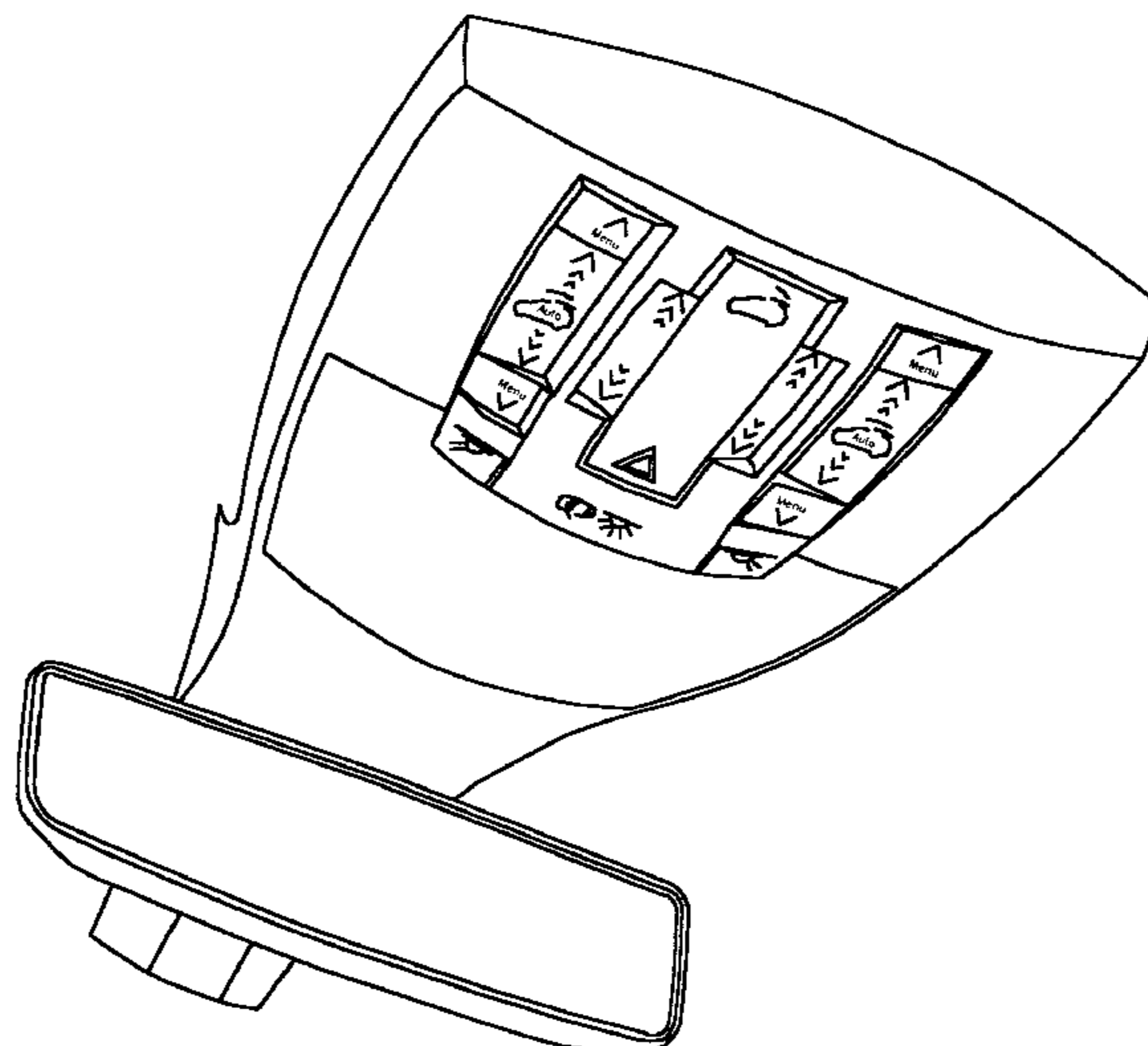

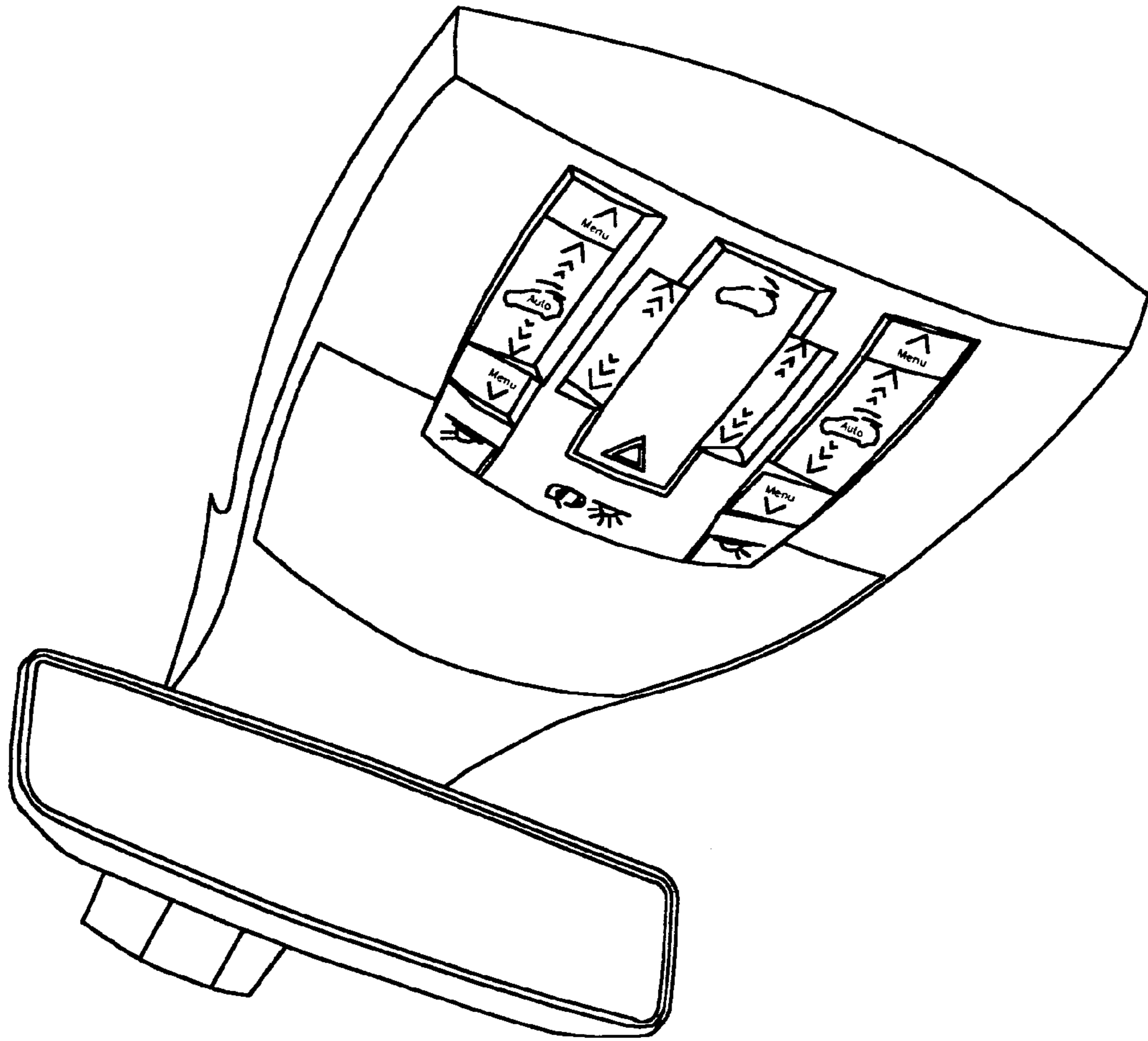

FIG. 1

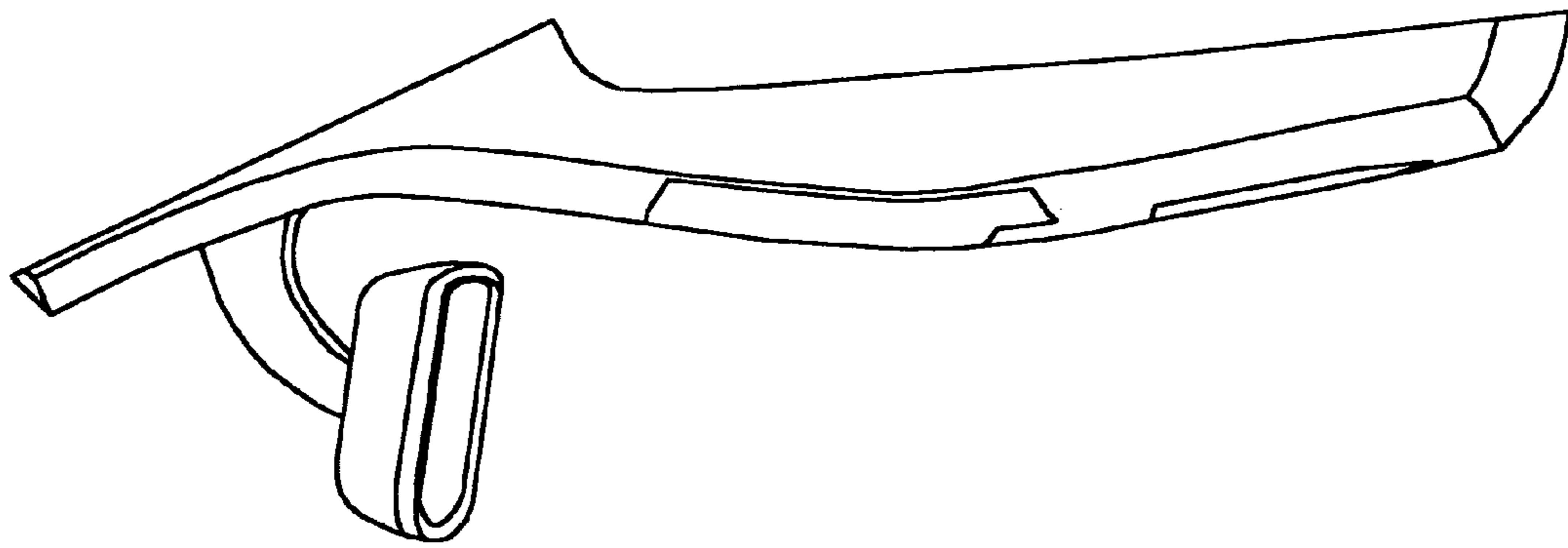

FIG. 2

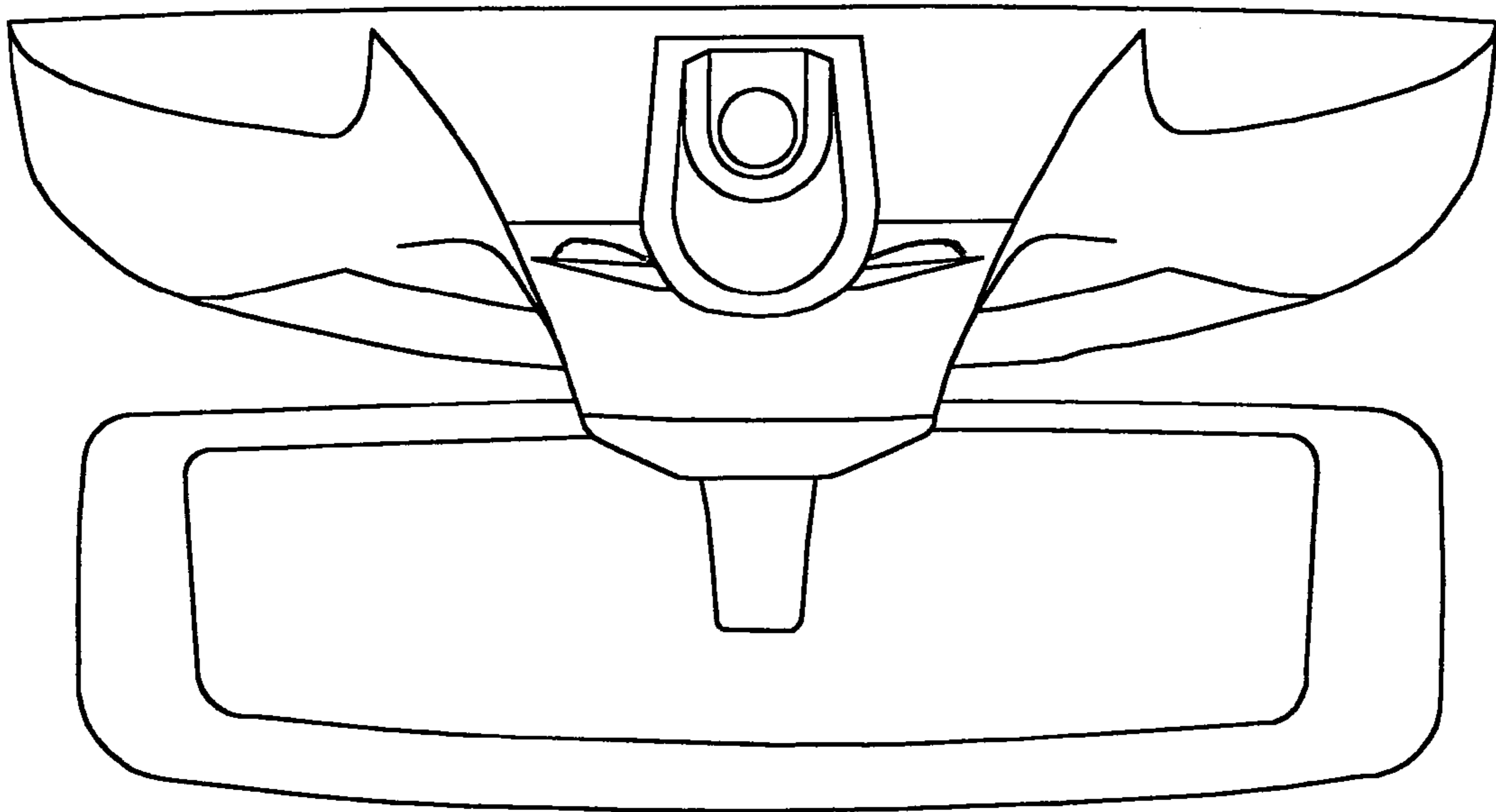

FIG. 3

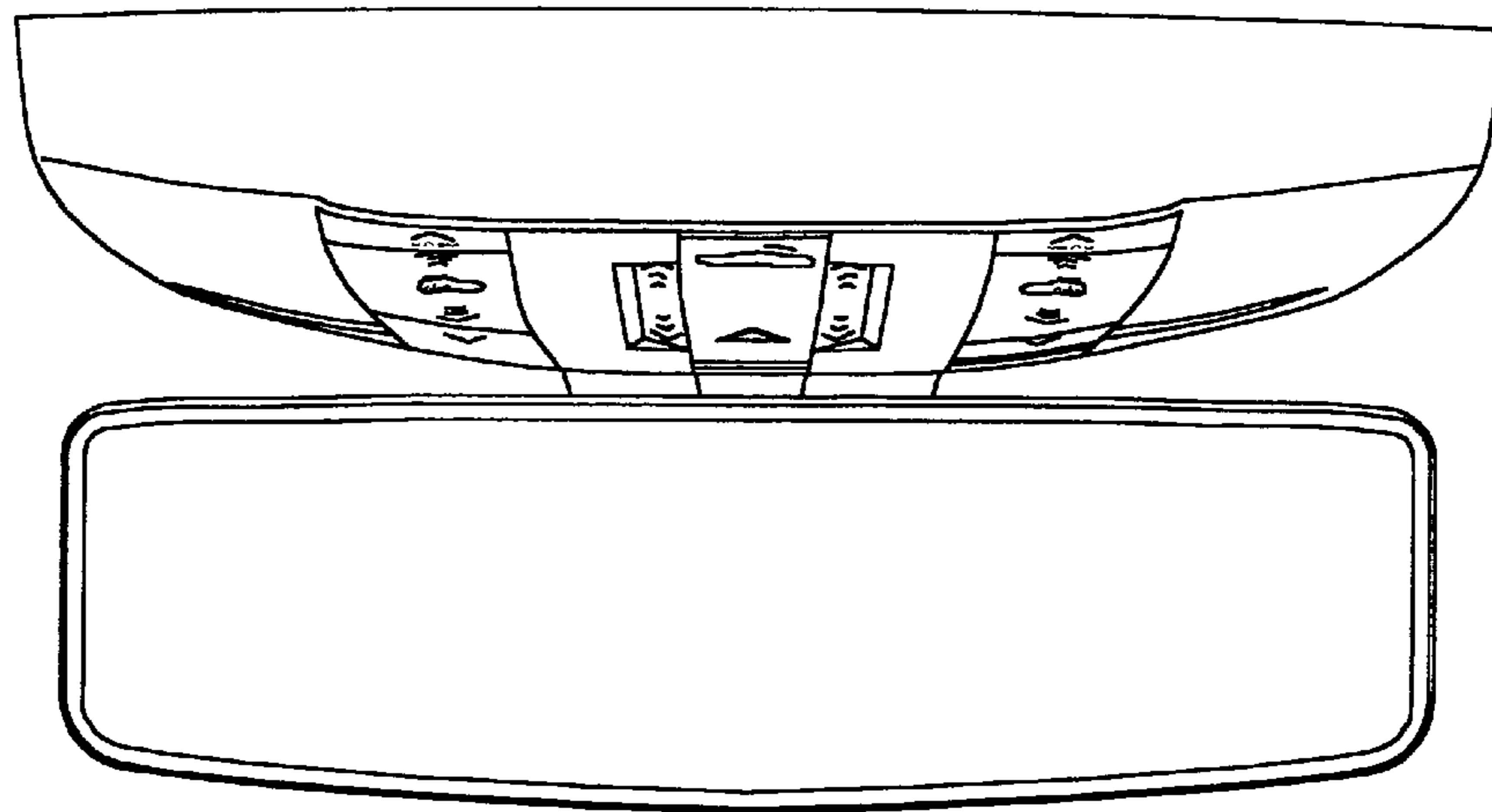

FIG. 4

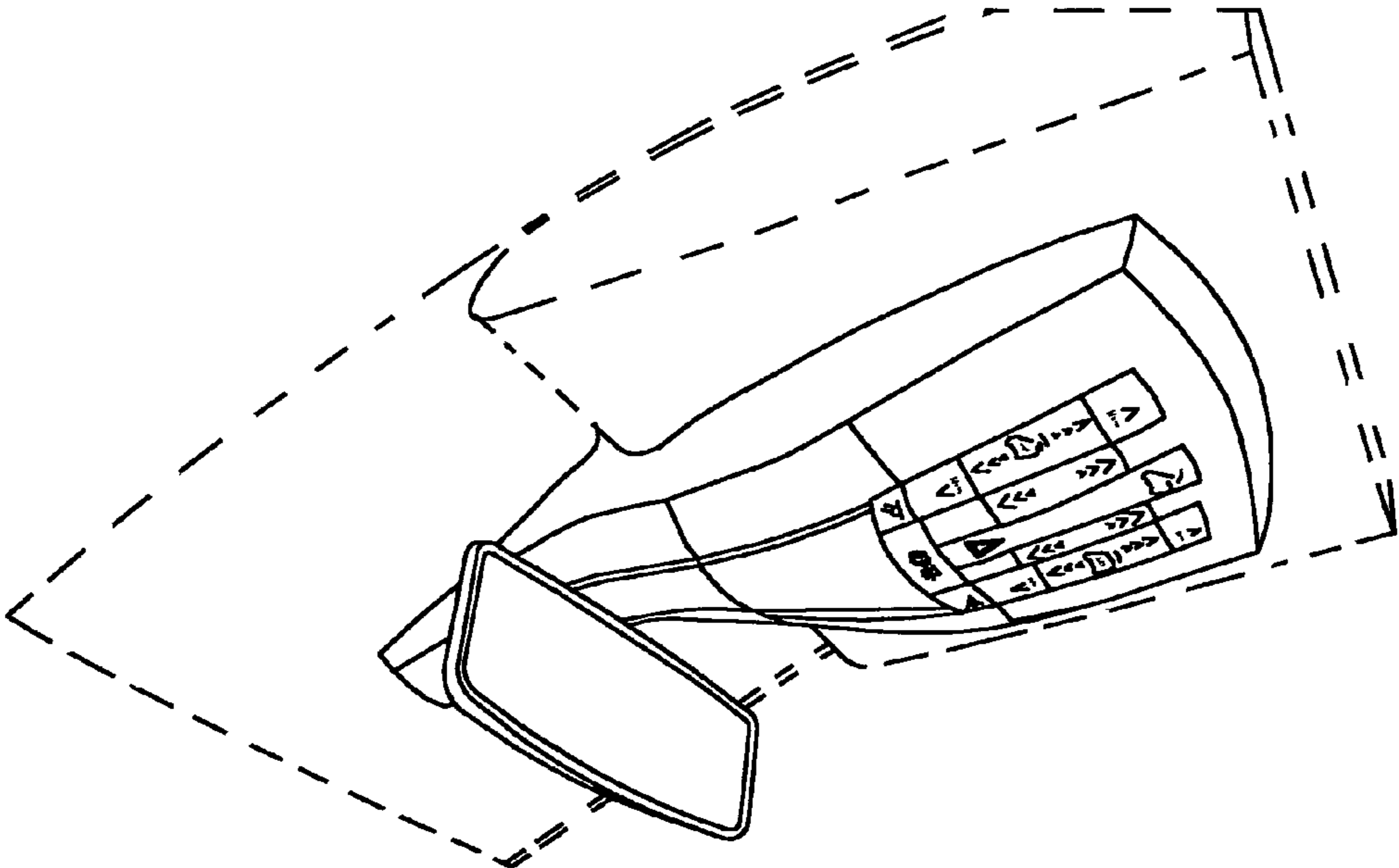

FIG. 5

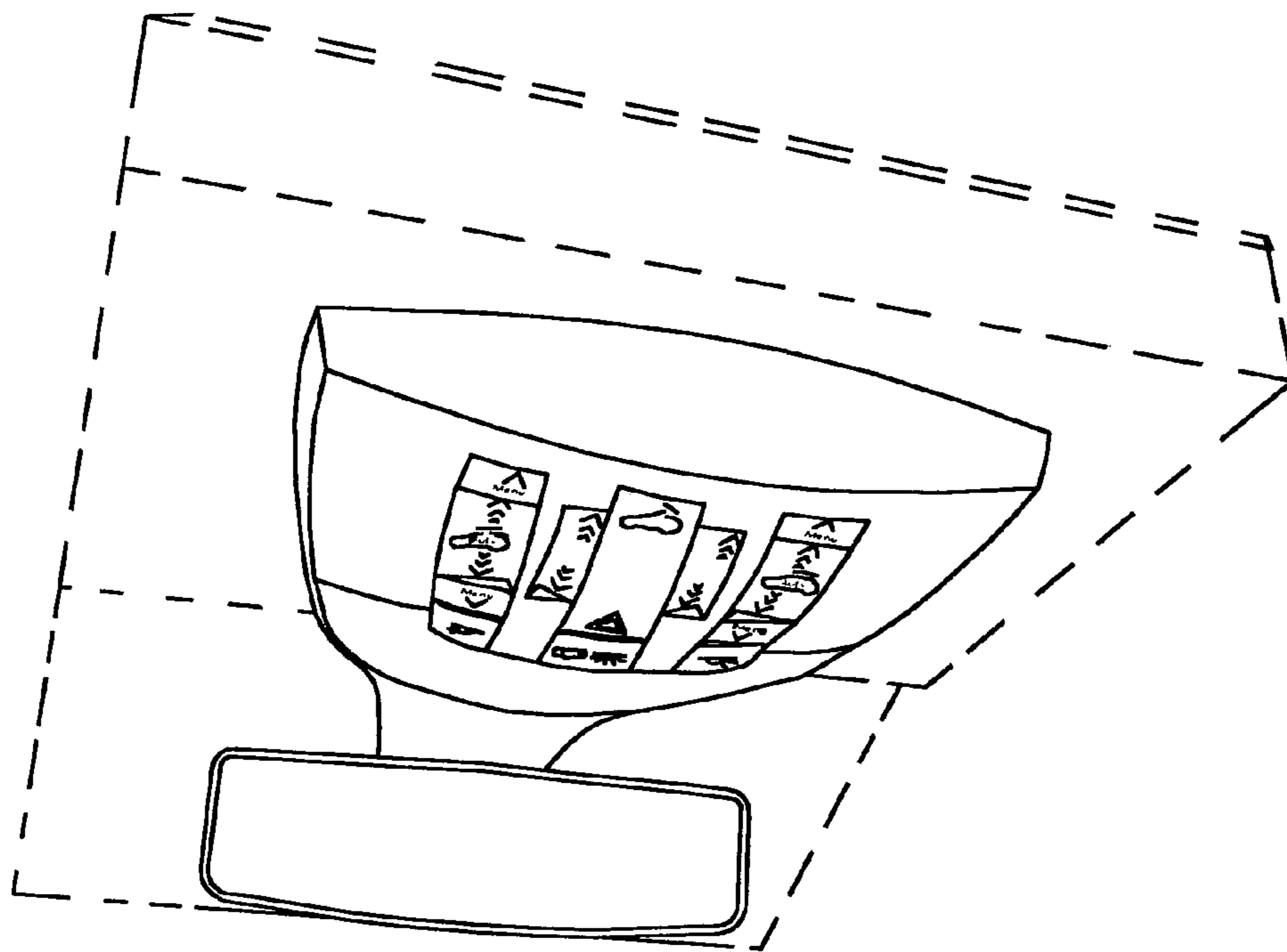

FIG. 6



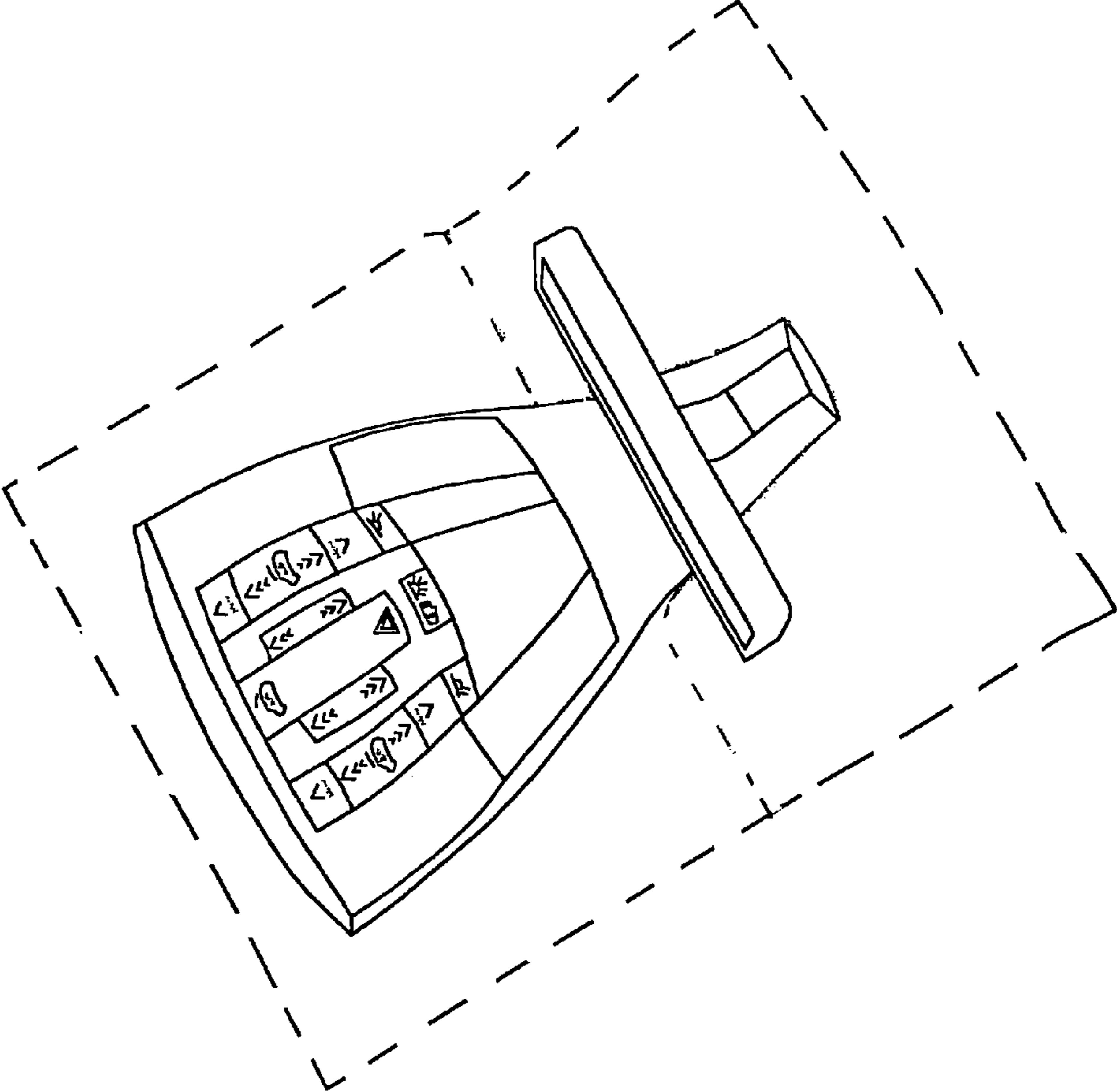

FIG. 7



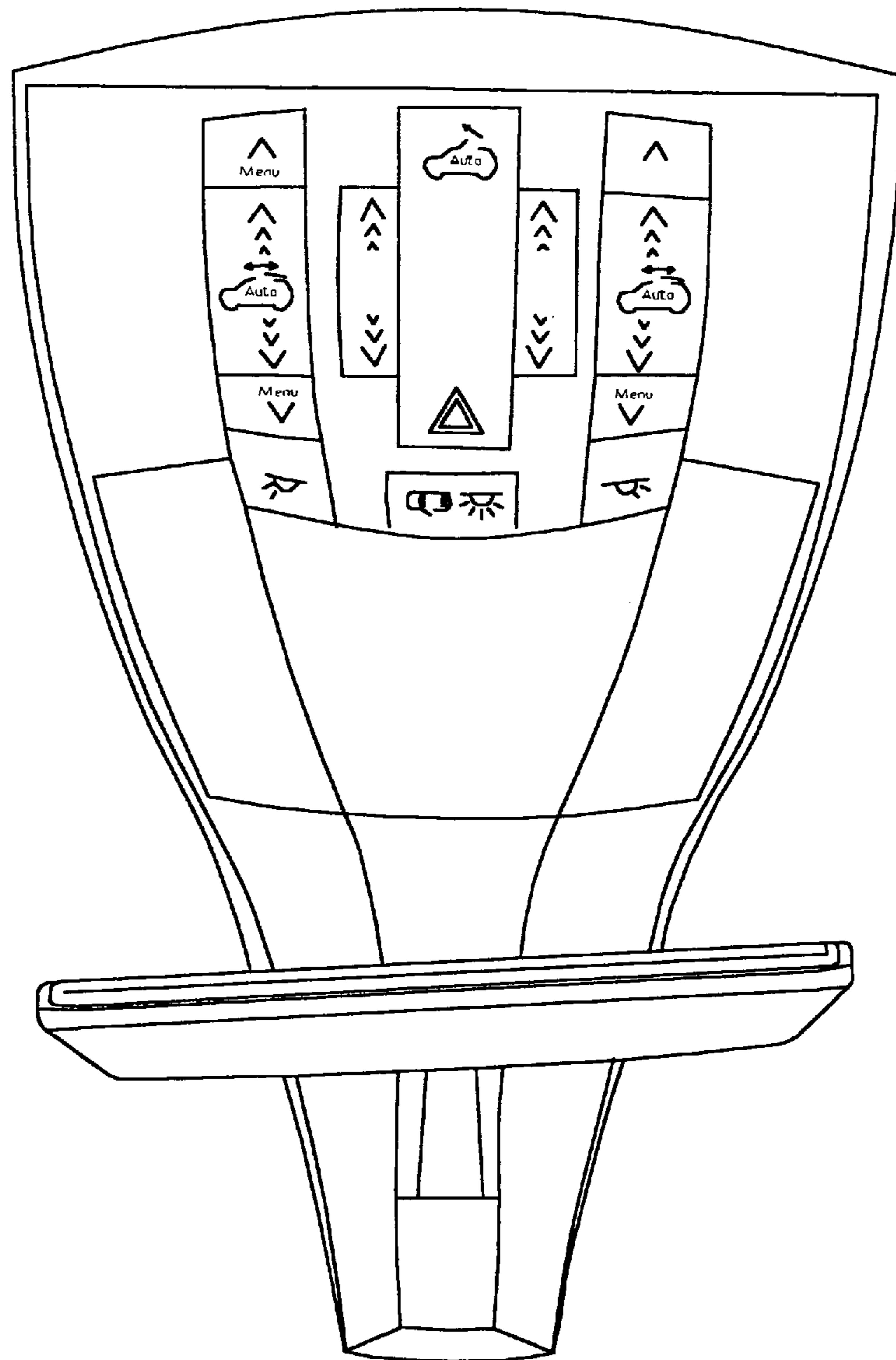

FIG. 8