



US00D571180S

(12) **United States Design Patent**  
**Marshall**

(10) **Patent No.:** **US D571,180 S**  
(45) **Date of Patent:** **\*\* Jun. 17, 2008**

(54) **SAFETY KNIFE**  
(75) Inventor: **Peter Marshall**, Gloucester (GB)  
(73) Assignee: **The Safety Knife Company Limited**,  
Gloucester (GB)

5,758,423 A \* 6/1998 Eversole et al. .... 30/279.2  
D405,674 S \* 2/1999 Reidenbach ..... D8/102  
D421,889 S \* 3/2000 Moore ..... D8/102  
D481,609 S \* 11/2003 Perlmutter et al. .... D8/99  
D498,404 S \* 11/2004 Schmidt ..... D8/98  
D527,604 S \* 9/2006 Kempker et al. .... D8/98

(\*\*) Term: **14 Years**

\* cited by examiner

(21) Appl. No.: **29/267,542**

*Primary Examiner*—Philip S Hyder

(22) Filed: **Oct. 17, 2006**

(74) *Attorney, Agent, or Firm*—Skinner and Associates

(30) **Foreign Application Priority Data**

Apr. 20, 2006 (EM) ..... 000519855-0001

(57) **CLAIM**

The ornamental design for a safety knife, as shown.

(51) **LOC (8) Cl.** ..... **08-03**  
(52) **U.S. Cl.** ..... **D8/98**  
(58) **Field of Classification Search** ..... D8/99,  
D8/98, 102, 14; 30/280, 294, 279.2, 287,  
30/289

**DESCRIPTION**

FIG. 1 is a perspective view of the safety knife;  
FIG. 2 is a front view of the safety knife;  
FIG. 3 is a rear view of the safety knife;  
FIG. 4 is a top view of the safety knife;  
FIG. 5 is a bottom view of the safety knife;  
FIG. 6 is a right side view of the safety knife; and,  
FIG. 7 is a left side view of the safety knife.

See application file for complete search history.

The broken line portions of the drawings form no part of the claimed design.

(56) **References Cited**

**U.S. PATENT DOCUMENTS**

D365,267 S \* 12/1995 Goessling et al. .... D8/102  
D372,184 S \* 7/1996 Bender, Jr. .... D8/102  
5,561,905 A \* 10/1996 Sherman ..... 30/280  
D377,595 S \* 1/1997 Wiezenhal ..... D8/98

**1 Claim, 2 Drawing Sheets**

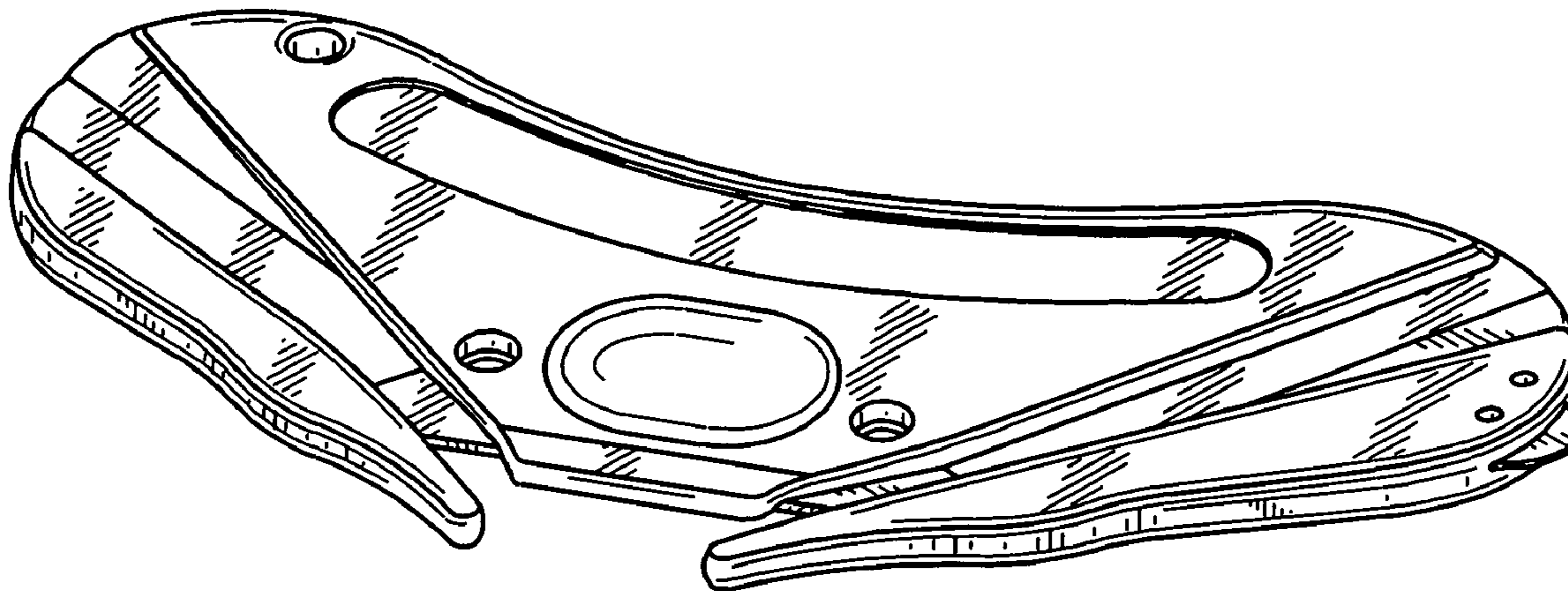

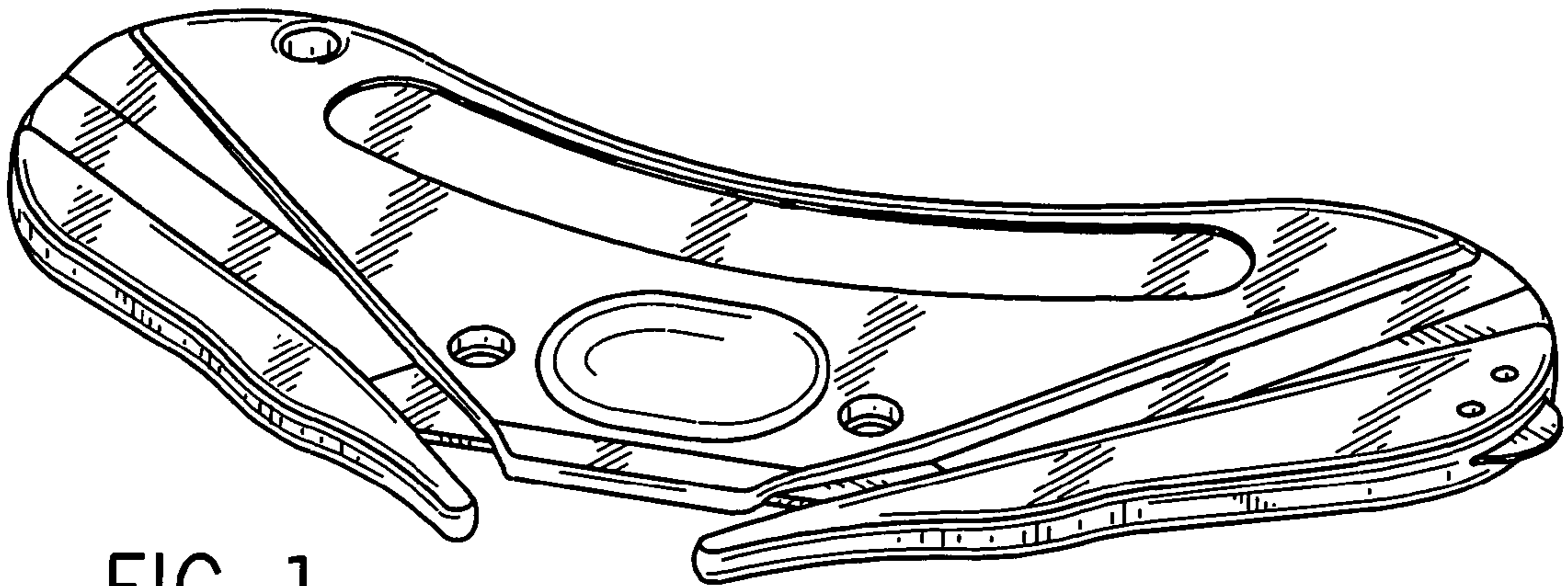

FIG. 1

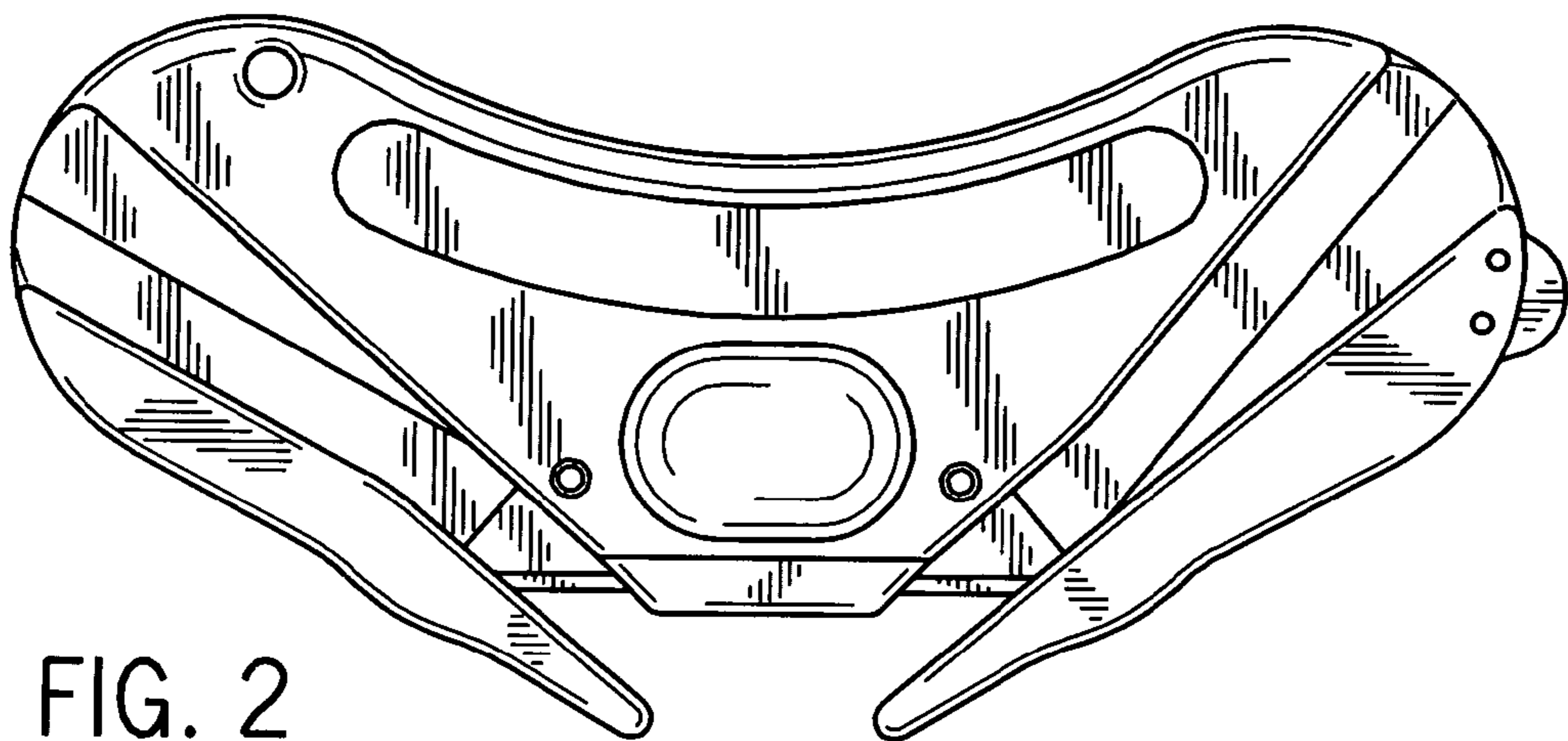

FIG. 2

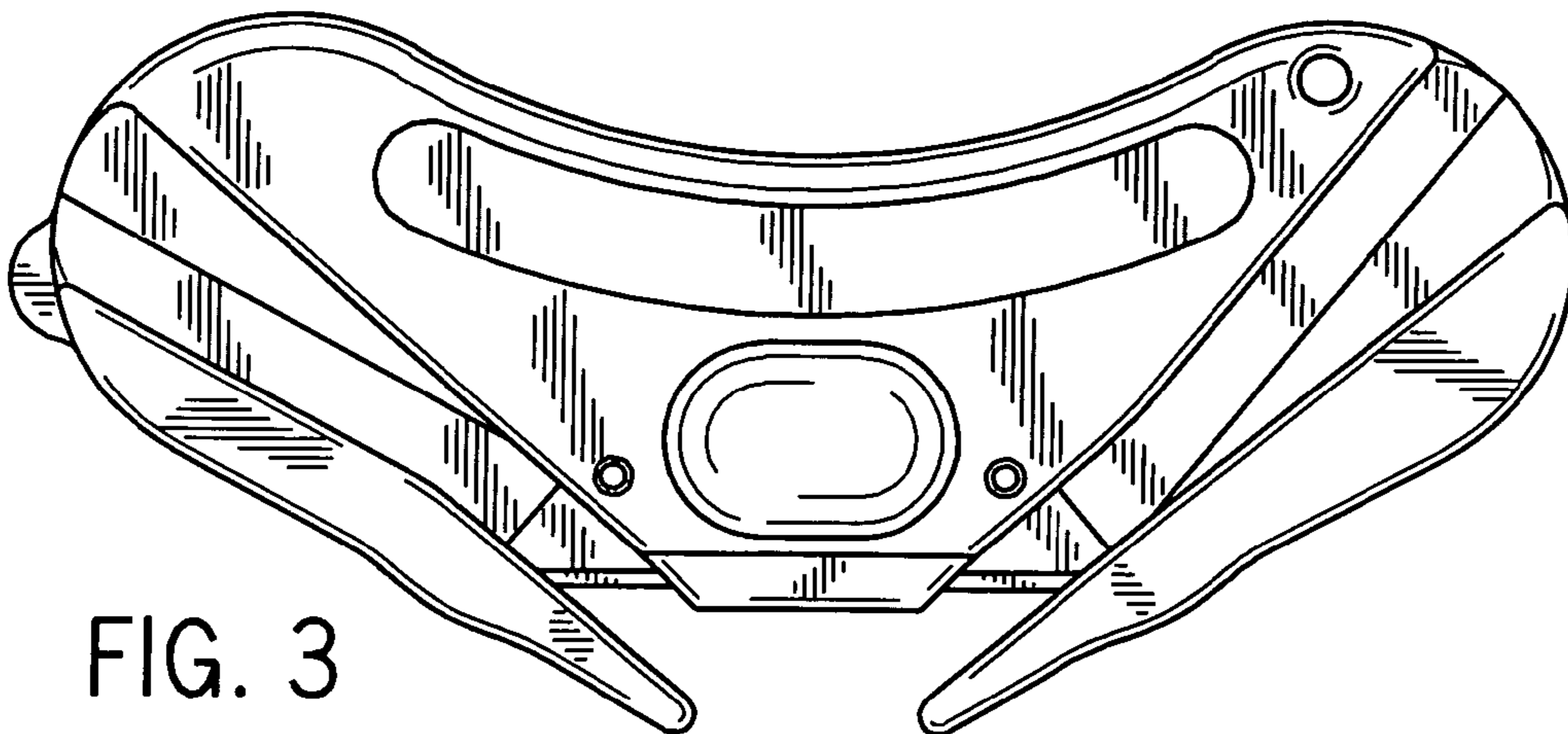

FIG. 3



FIG. 4

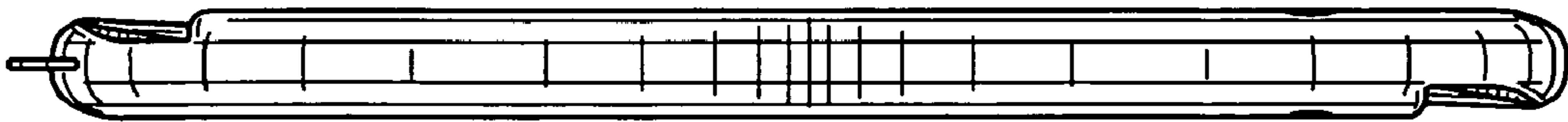

FIG. 5

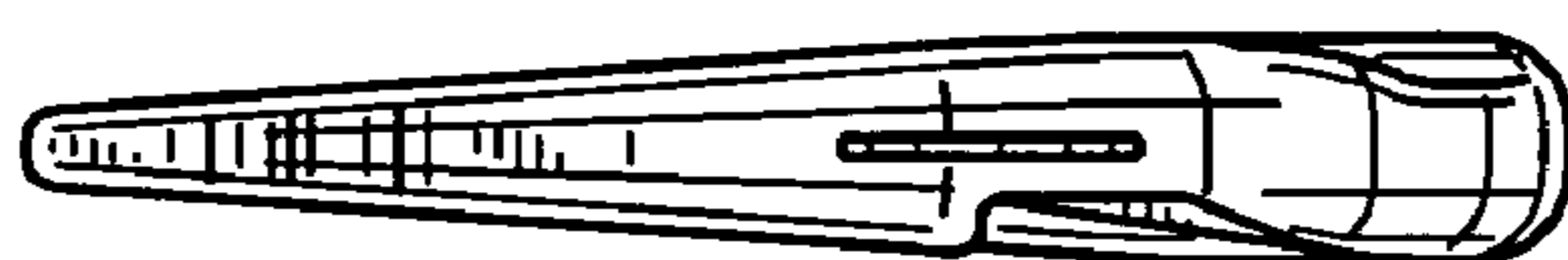

FIG. 6

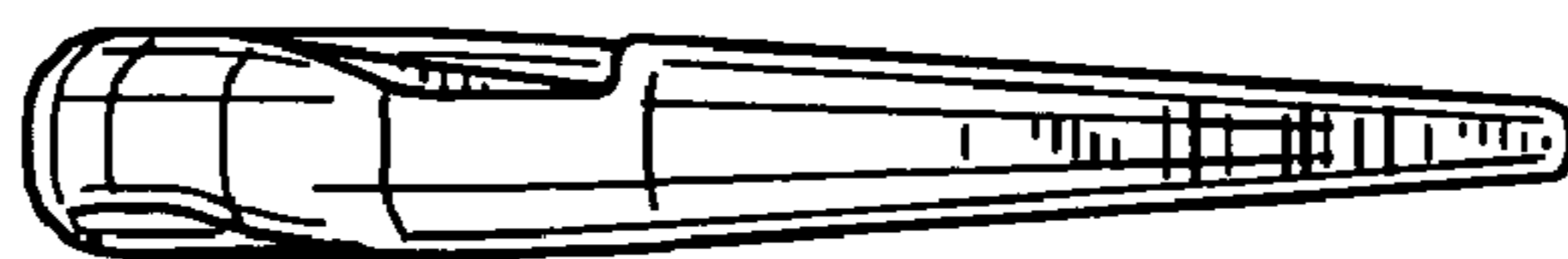

FIG. 7