



US00D571139S

(12) **United States Design Patent**
Knee et al.

(10) **Patent No.:** **US D571,139 S**
(45) **Date of Patent:** **** Jun. 17, 2008**

(54) **BED RAIL COVER**

(75) Inventors: **Barrie Knee**, 7 Jackson Ct., Monmouth Beach, NJ (US) 07750-1058; **Ilene Gore**, Fair Haven, NJ (US)

(73) Assignee: **Barrie Knee**, Short Hills, NJ (US)

(**) Term: **14 Years**

(21) Appl. No.: **29/289,193**

(22) Filed: **Jul. 11, 2007**

(51) **LOC (8) Cl.** **06-13**

(52) **U.S. Cl.** **D6/610**

(58) **Field of Classification Search** D6/610,
D6/611, 612, 616, 596, 601, 606, 607, 624;
5/663, 512, 946, 93.1, 100; 160/638.1, 327-329,
160/330, 348, 349.1, 45, 46, 35, 84.03; 128/872;
D25/57

See application file for complete search history.

(56) **References Cited**

U.S. PATENT DOCUMENTS

1,416,304	A *	5/1922	Robinson	160/327
1,970,256	A *	8/1934	Terrel	160/327
3,877,090	A *	4/1975	Schutz	5/93.1
3,996,987	A *	12/1976	Rodriguez	160/330
5,319,870	A *	6/1994	Weiss	160/329
D365,957	S *	1/1996	Ferrari	D6/606

5,768,722	A *	6/1998	Olson et al.	5/512
5,898,964	A *	5/1999	Stanley	5/663
D427,834	S *	7/2000	Buckley	D6/610
6,178,573	B1 *	1/2001	Wagner et al.	5/946
6,530,413	B2 *	3/2003	Hwang	160/84.03
6,550,525	B1 *	4/2003	Grisolia	160/349.1
D484,347	S *	12/2003	Curran	D6/596
D510,217	S *	10/2005	Neveau	D6/596
2004/0045684	A1 *	3/2004	Smith et al.	160/348
2006/0060314	A1 *	3/2006	Battista	160/330

* cited by examiner

Primary Examiner—Louis S Zarfaz

Assistant Examiner—David G Muller

(74) *Attorney, Agent, or Firm*—Mandel & Peslak, LLC;
Arthur M. Peslak

(57) **CLAIM**

The ornamental design for a bed rail cover, as shown and described.

DESCRIPTION

FIG. 1 is a front perspective view of the bed rail cover of the present invention.

FIG. 2 is a front elevation view of the bed rail cover of the present invention; and,

FIG. 3 is a side elevation view of the bed rail cover of the present invention.

1 Claim, 3 Drawing Sheets

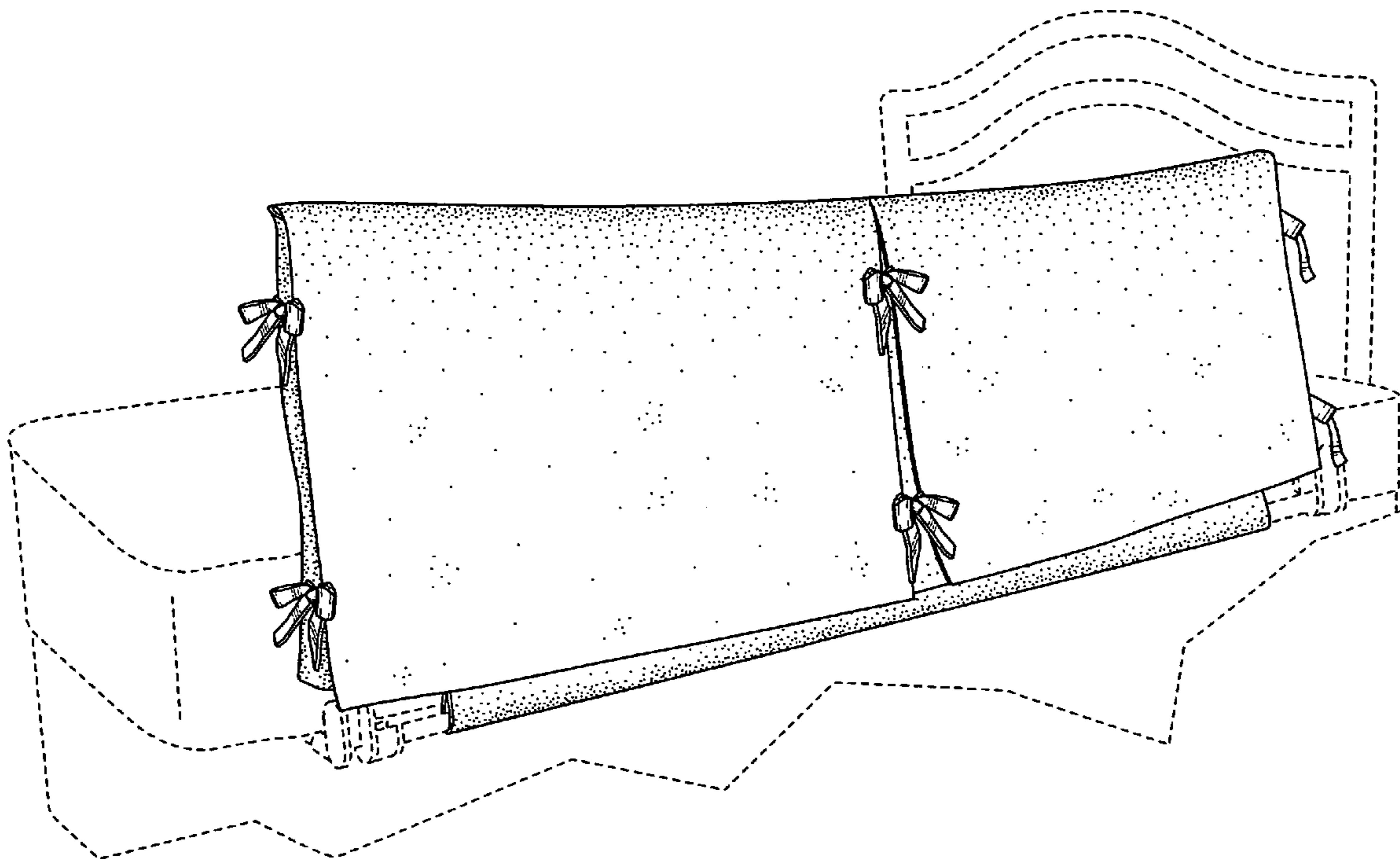

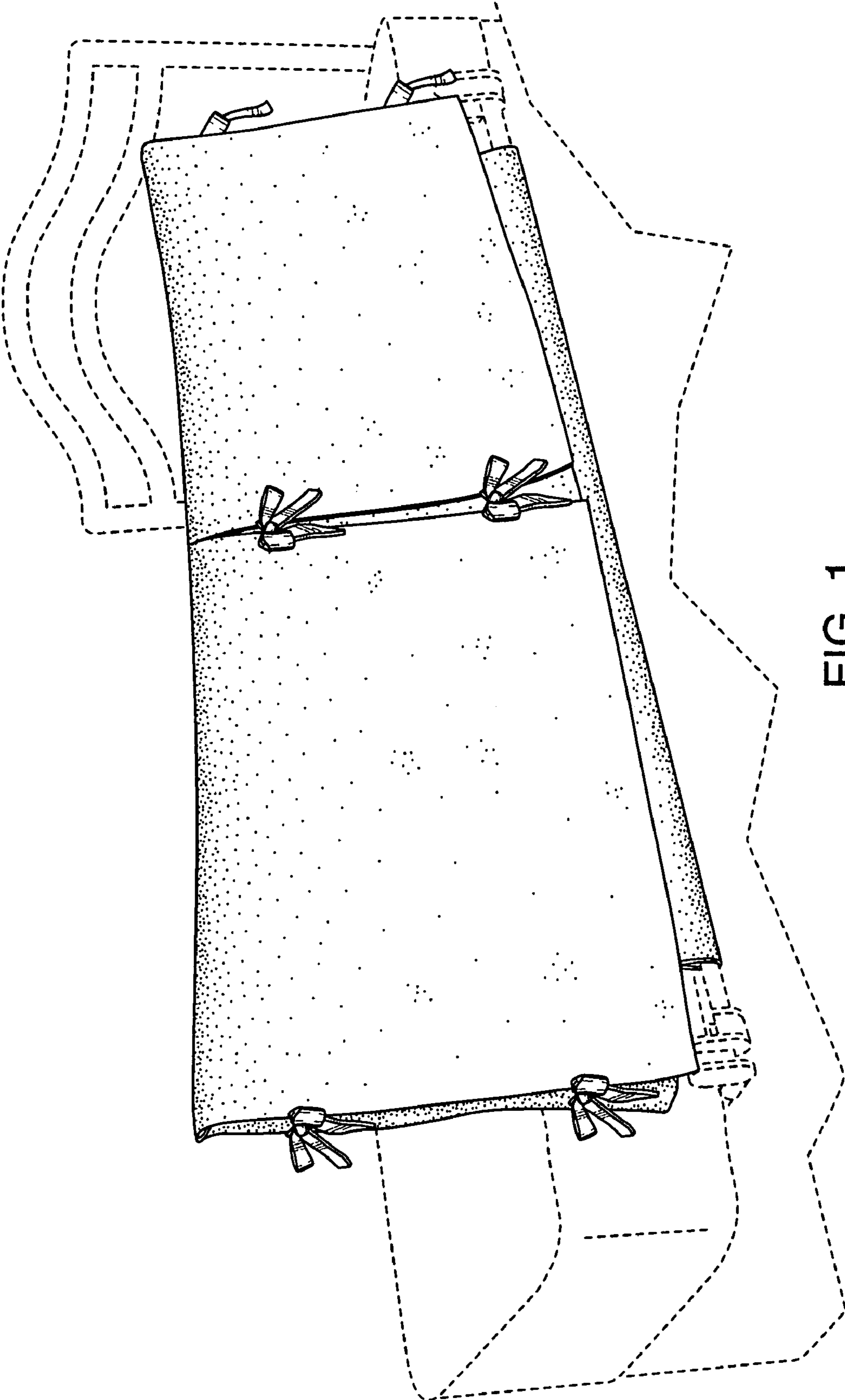

FIG. 1

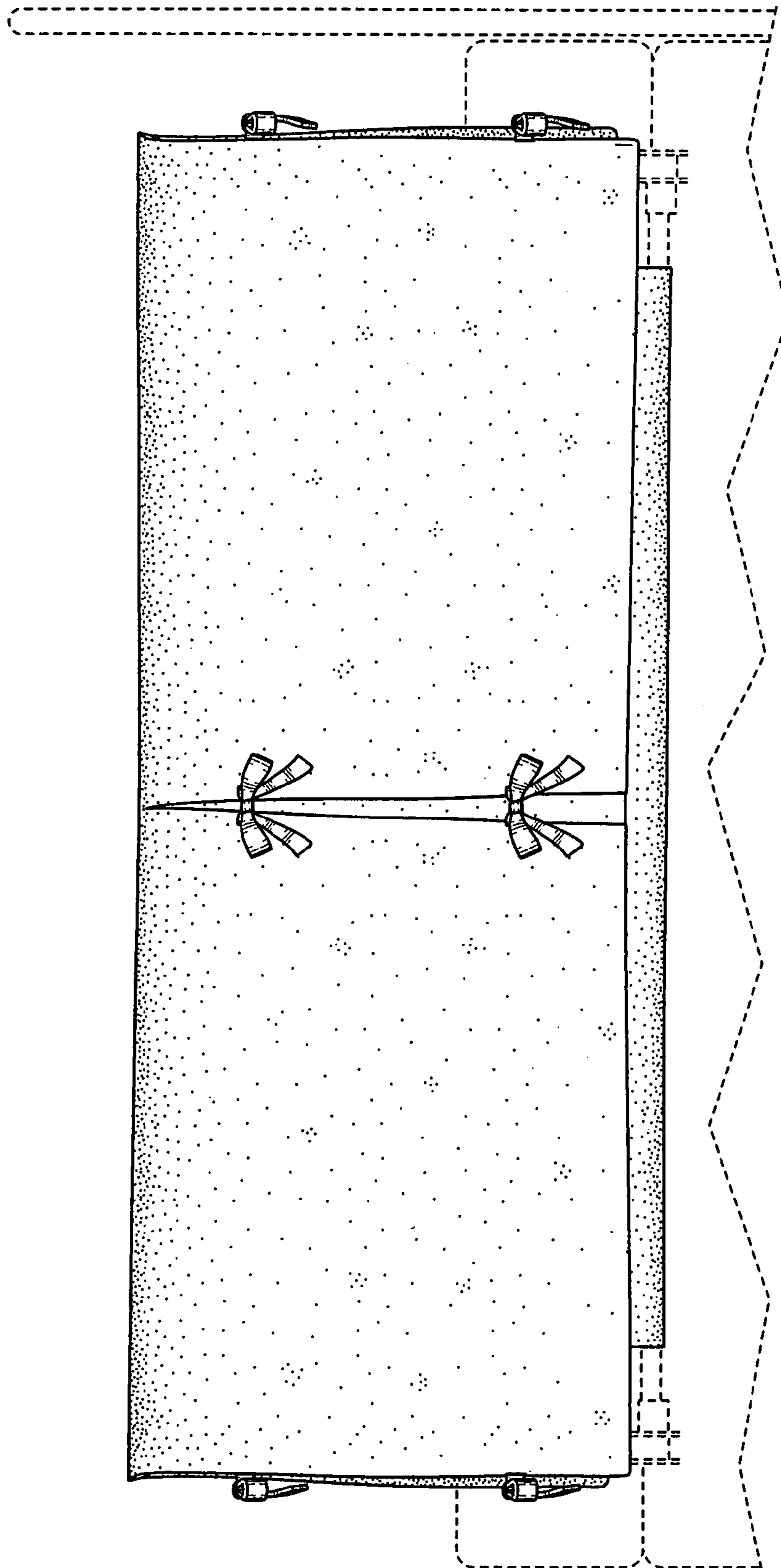

FIG. 2

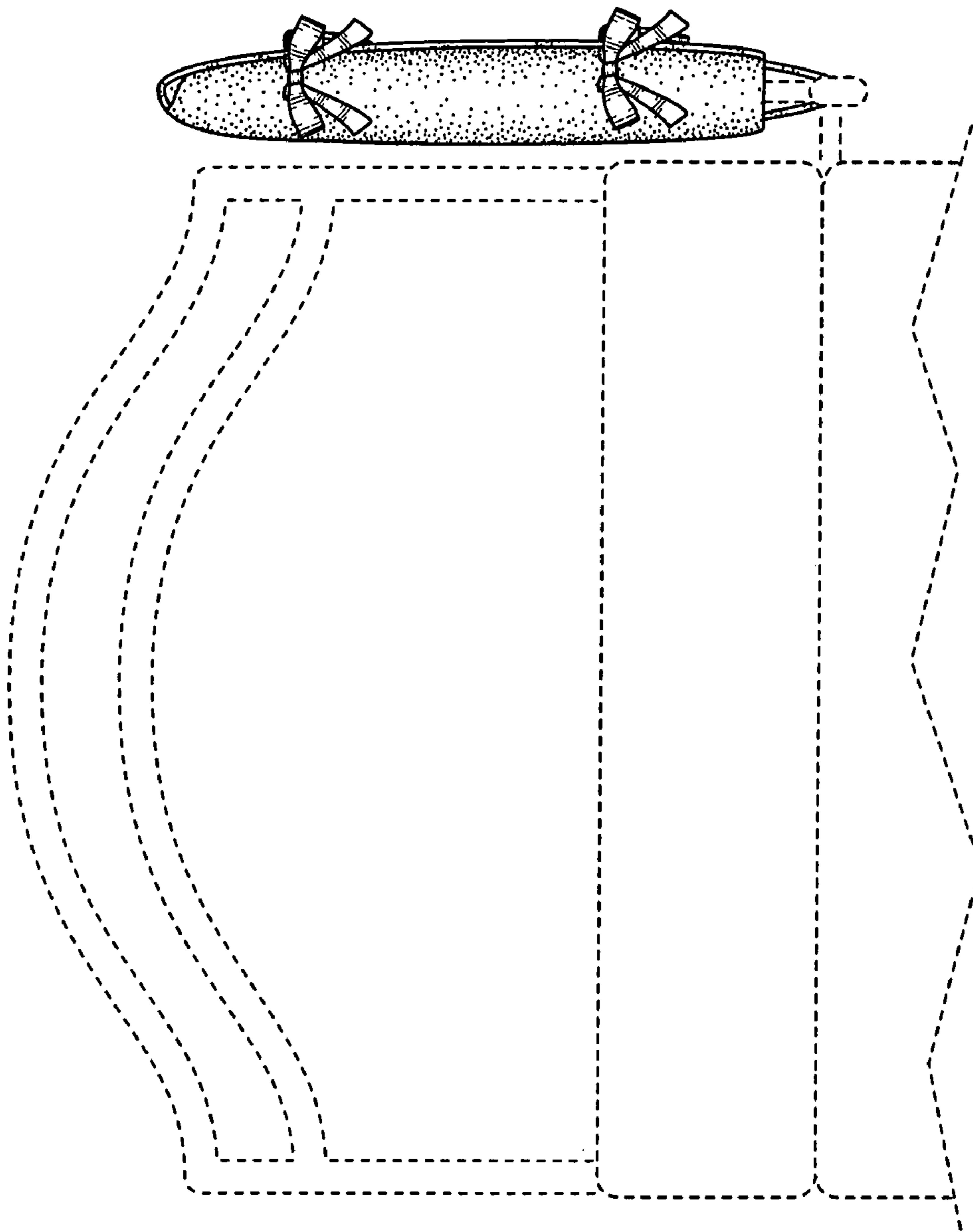

FIG. 3