



US00D570826S

(12) **United States Design Patent**  
**Fong**

(10) **Patent No.:** **US D570,826 S**  
(45) **Date of Patent:** **\*\* Jun. 10, 2008**

(54) **BOTTLE-SHAPED PORTABLE MUSIC  
PLAYER SPEAKER AND AMPLIFIER  
ASSEMBLY**

*Primary Examiner*—Nanda Bondade  
(74) *Attorney, Agent, or Firm*—William Keyworth; Bill & Mary Lou Inc.

(76) Inventor: **Barre Jay Fong**, 1776 11th Ave., San Francisco, CA (US) 94122

(57) **CLAIM**

(\*\*) Term: **14 Years**

The ornamental design for a bottle-shaped portable music player speaker and amplifier assembly, as shown and described.

(21) Appl. No.: **29/247,960**

(22) Filed: **Jul. 21, 2006**

(51) **LOC (8) Cl.** ..... **14-01**

(52) **U.S. Cl.** ..... **D14/207**

(58) **Field of Classification Search** ..... D14/204,  
D14/207, 209–217; D9/453, 500, 504; 181/143–148,  
181/150, 157, 198–199, 151, 153; 381/300–302,  
381/306, 333, 345, 361–364, 386–388, 332,  
381/336; D24/197; 215/252, 258  
See application file for complete search history.

**DESCRIPTION**

(56) **References Cited**

**U.S. PATENT DOCUMENTS**

4,981,230	A *	1/1991	Marshall et al.	.....	215/252
D375,746	S *	11/1996	Wu	.....	D14/216
6,053,343	A *	4/2000	Krueger	.....	215/209
D435,450	S *	12/2000	Eisenbarth	.....	D9/500
D451,393	S *	12/2001	Gerhart et al.	.....	D9/453
D474,172	S *	5/2003	Jacobson	.....	D14/207
D498,228	S *	11/2004	Kasden	.....	D14/207

FIG. 1 is an exploded perspective view of a bottle-shaped portable music player speaker and amplifier assembly showing my new design;

FIG. 2 is front elevational view thereof;

FIG. 3 is a right side elevational view thereof, the opposite side being a mirror image;

FIG. 4 is a rear elevational view thereof;

FIG. 5 is a top plan view thereof;

FIG. 6 is a bottom plan view thereof; and,

FIG. 7 is a reduced perspective view thereof.

The broken line showing on the drawing disclosure is for illustrative purposes only and forms no part of the claimed design.

\* cited by examiner

**1 Claim, 3 Drawing Sheets**

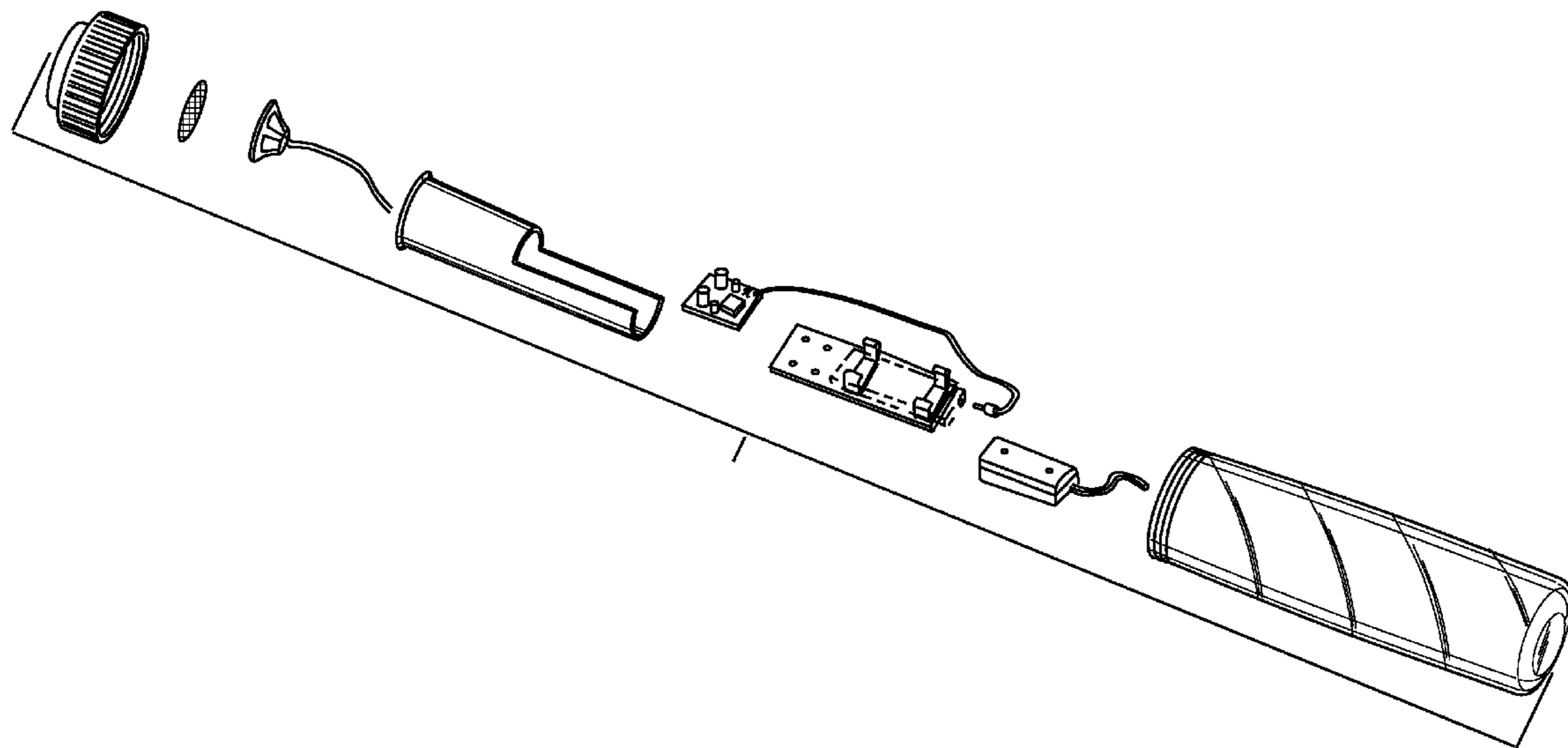

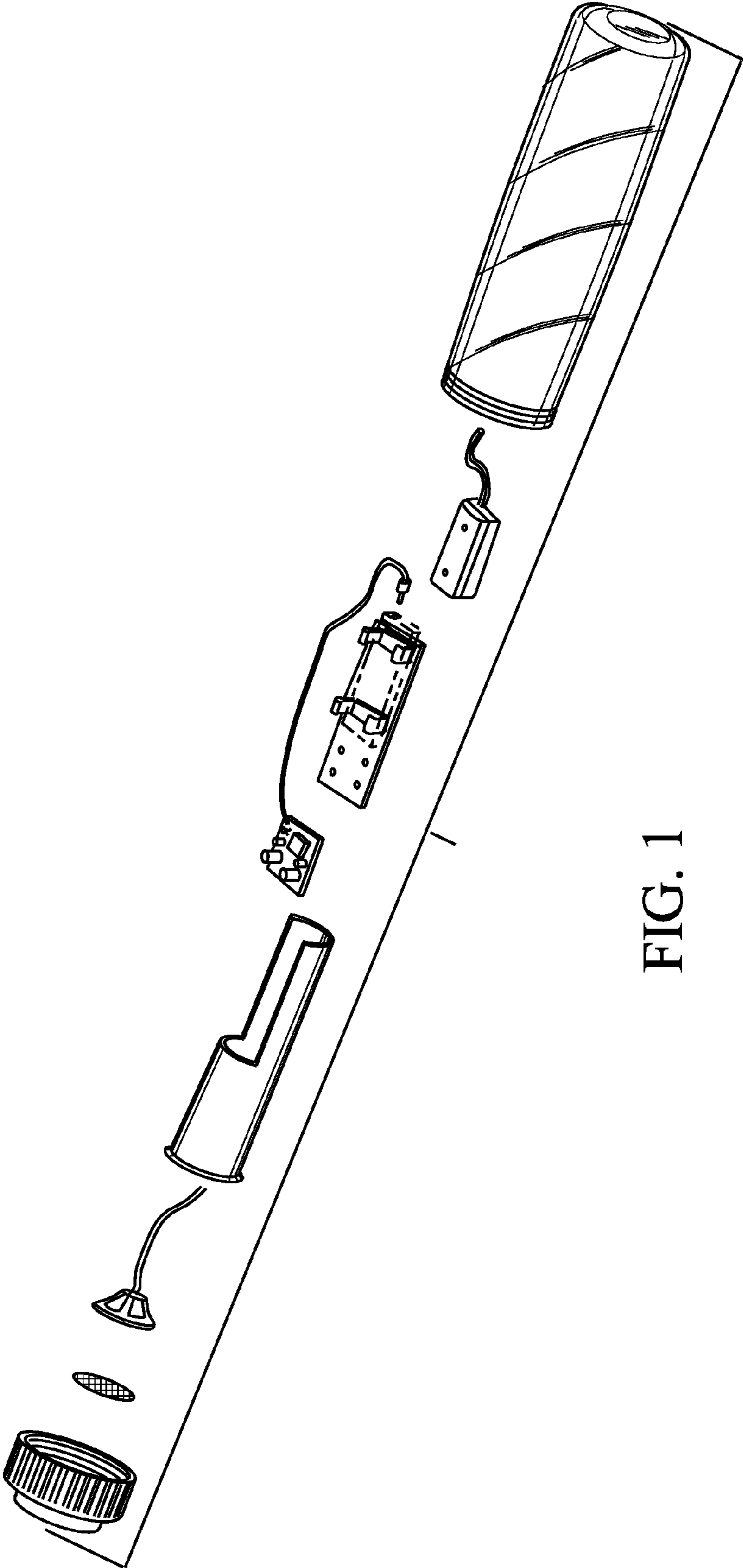

FIG. 1

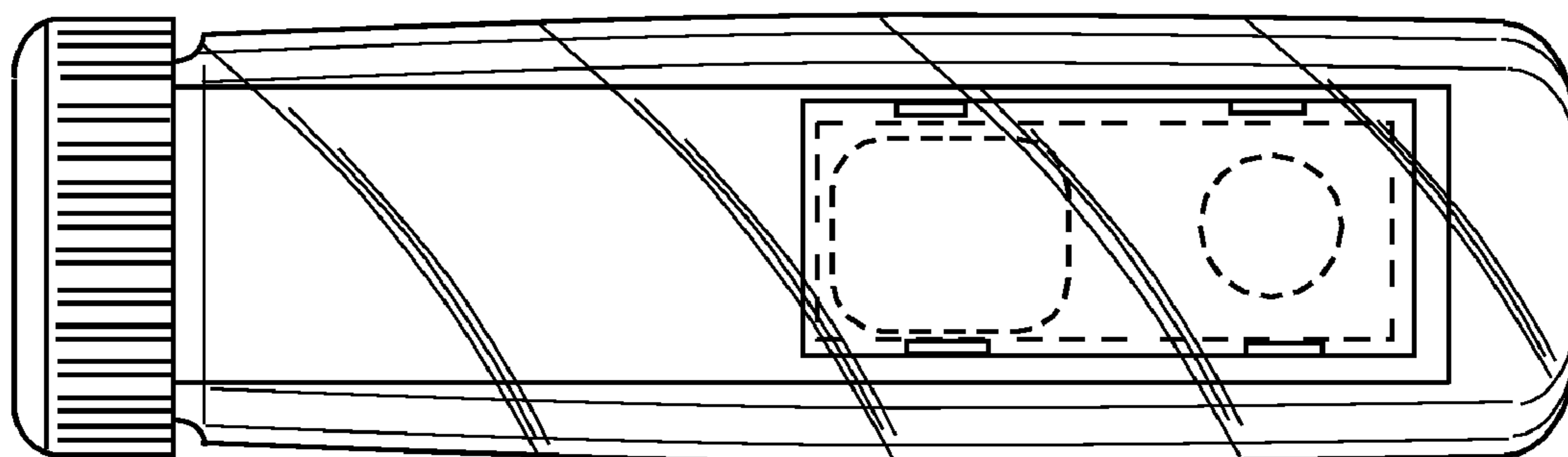

Fig. 2

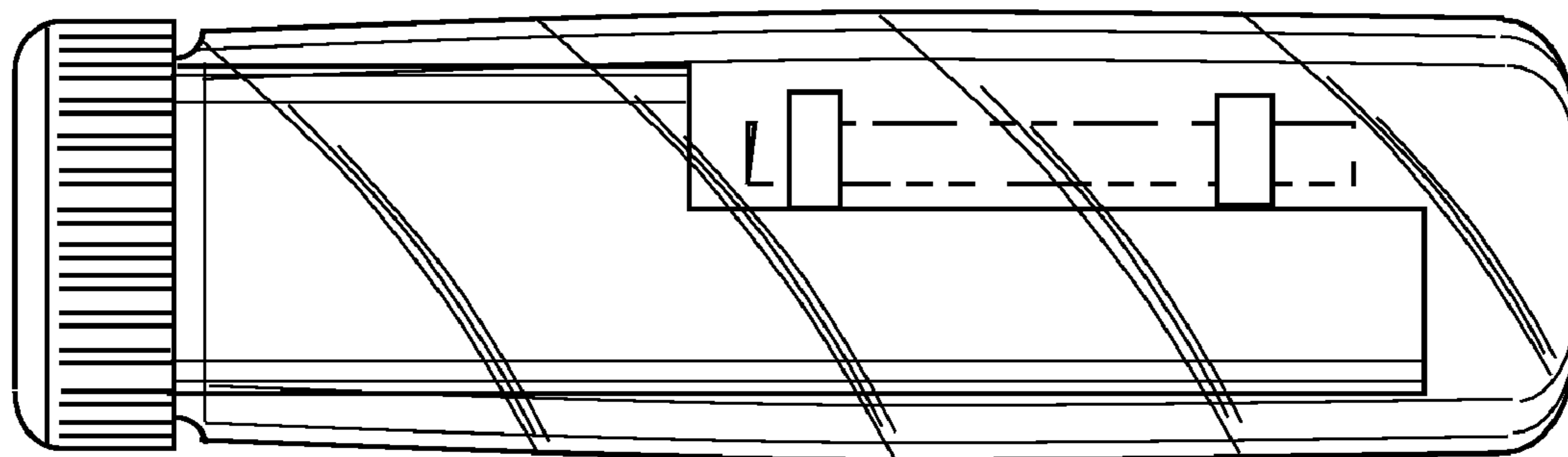

Fig. 3

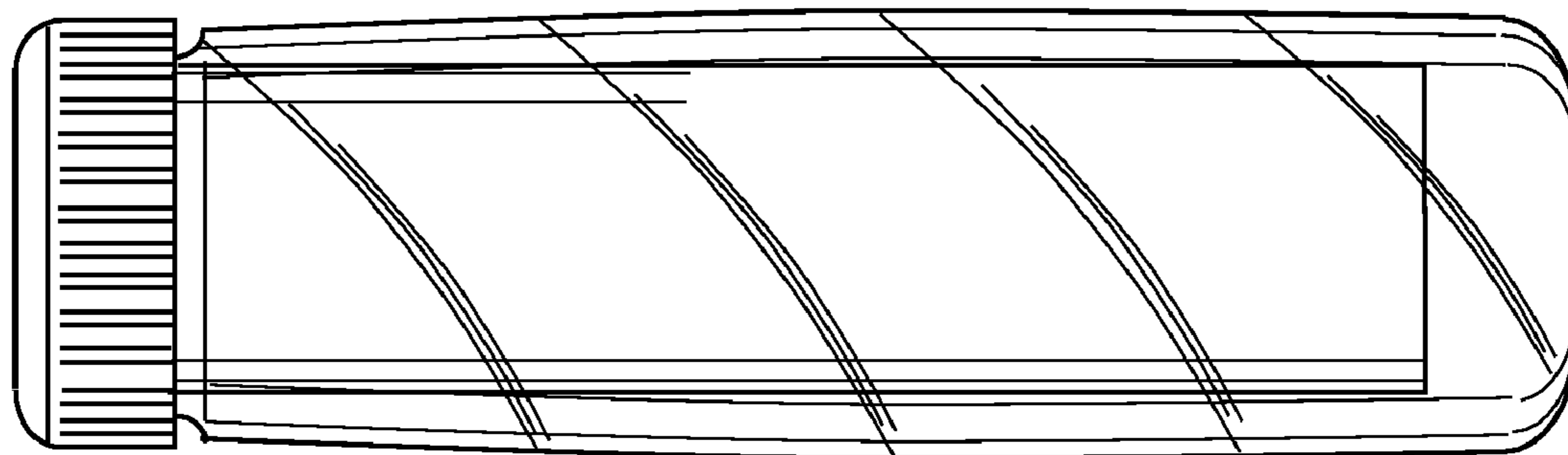

Fig. 4

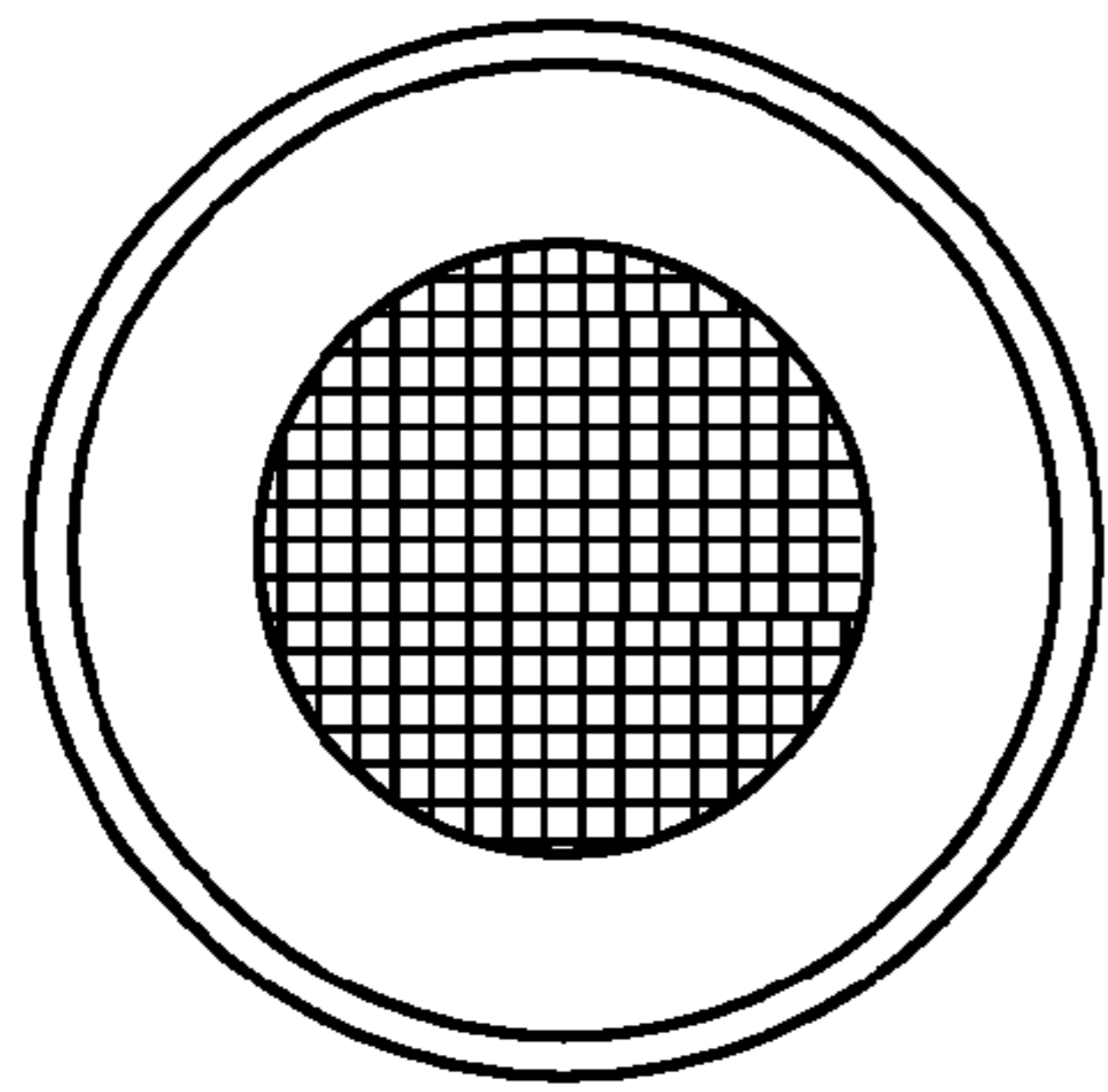

Fig. 5

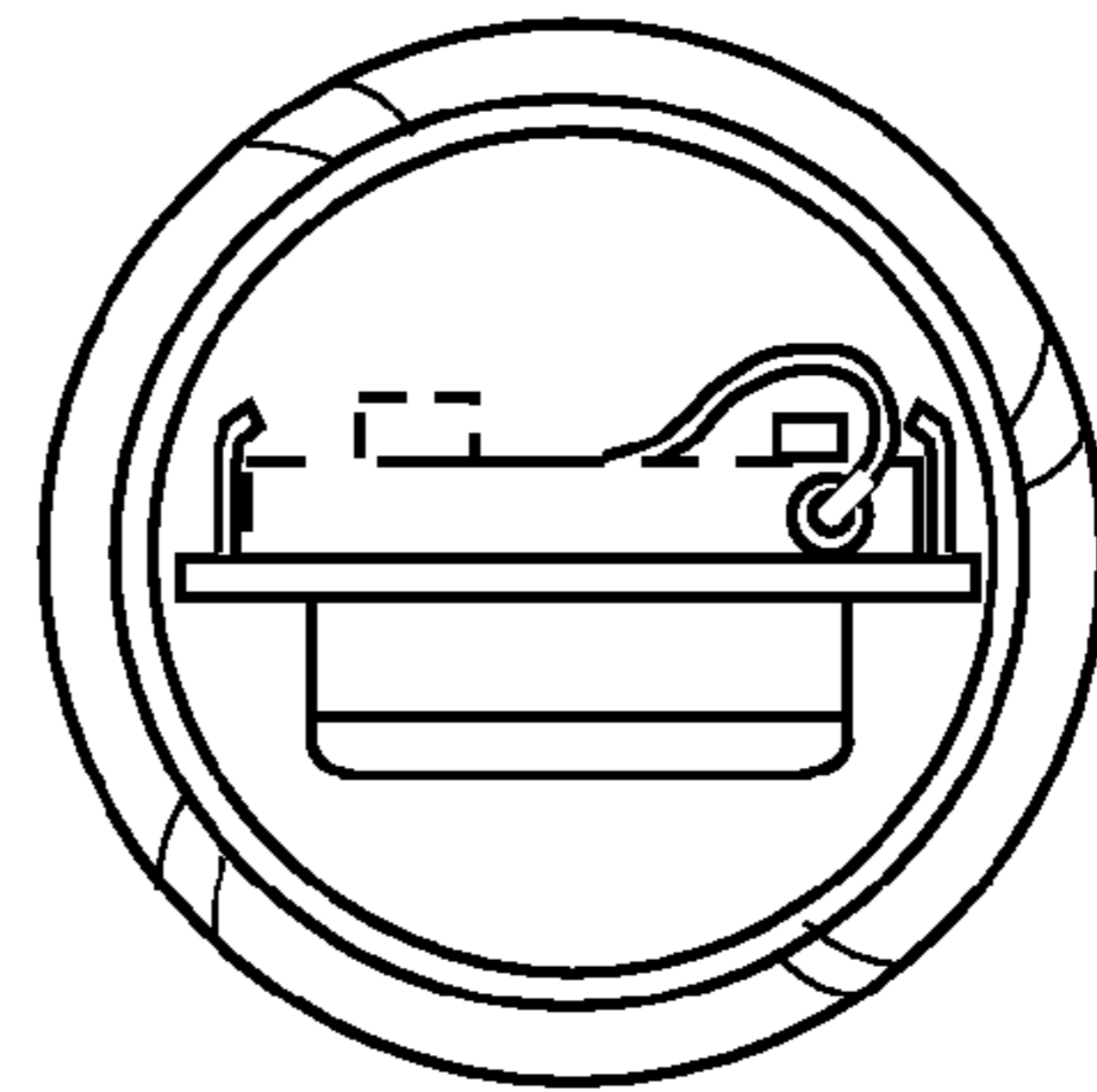

Fig. 6



Fig. 7