

US00D570778S

(12) **United States Design Patent** (10) **Patent No.:** **US D570,778 S**  
**Yu et al.** (45) **Date of Patent:** **\*\* Jun. 10, 2008**

(54) **COMBINED PLUGGABLE OPTICAL  
TRANSCIVER AND LATCH-RELEASE  
SLEEVE**

(74) *Attorney, Agent, or Firm*—Foley & Lardner LLP

(75) Inventors: **Juhyun Yu**, Hitachi (JP); **Yoshinori  
Sunaga**, Hitachinaka (JP)

(57) **CLAIM**

The ornamental design for a combined pluggable optical transceiver and latch-release sleeve, as shown and described.

(73) Assignee: **Hitachi Cable, Ltd.**, Tokyo (JP)

**DESCRIPTION**

(\*\*) Term: **14 Years**

(21) Appl. No.: **29/250,559**

(22) Filed: **Nov. 21, 2006**

(30) **Foreign Application Priority Data**

Jun. 26, 2006 (JP) ..... 2006-016513

(51) **LOC (8) Cl.** ..... **13-03**

(52) **U.S. Cl.** ..... **D13/123**

(58) **Field of Classification Search** ..... D13/123,  
D13/133, 146, 147, 184, 199; 385/88, 89,  
385/92, 385; 361/728, 754, 759; 439/357,  
439/372, 359, 358, 76.1, 607, 608, 609

See application file for complete search history.

(56) **References Cited**

**U.S. PATENT DOCUMENTS**

6,066,001	A *	5/2000	Liptak et al.	439/607
6,287,128	B1 *	9/2001	Jones et al.	439/76.1
6,350,063	B1 *	2/2002	Gilliland et al.	385/88
D478,868	S *	8/2003	Zaremba	D13/123
7,178,996	B2 *	2/2007	Malagrino et al.	385/92
2003/0198025	A1 *	10/2003	Cao	361/728
2003/0236019	A1 *	12/2003	Hanley et al.	439/372
2005/0286837	A1 *	12/2005	Oki et al.	385/92
2006/0078260	A1 *	4/2006	Ishigami	385/92
2006/0274518	A1 *	12/2006	Yu et al.	361/816
2007/0110374	A1 *	5/2007	Oki et al.	385/89
2007/0167077	A1 *	7/2007	Mizue	439/607

\* cited by examiner

*Primary Examiner*—Daniel Bui

*Assistant Examiner*—Thomas J Johannes

This article is a combined pluggable optical transceiver and latch-release sleeve, used for optical communication, and including an optical transmitter and an optical receiver that are integrally formed. The combined pluggable optical transceiver and latch-release sleeve has a latch mechanism that is plugged to a network apparatus to serve as a retainer when this article is installed on the network apparatus. The latch mechanism connected to a latch-release sleeve can be released by pulling the latch-release sleeve to the forward direction, so that this article can be detached from the network apparatus. Respective corners of the latch-release sleeve are formed to have a round shape, so that the latch-release sleeve can be easily hold along omni-direction, namely, vertical and horizontal directions. Upper and lower surfaces of the latch-release sleeve that are often held by a user are provided with plural grooves with a constant pitch to prevent the user's fingers from being slipped. Further, a height of the latch-release sleeve is slowly increased from a main body side to a front side thereof, such that a holding force can be easily transmitted to the latch mechanism. Still further, the latch-release sleeve is provided with a stopper for limiting a front position thereof with respect to an optical transceiver housing, to avoid an application of an excessive force being to the latch mechanism.

FIG. 1 is an enlarged top, front and right side perspective view of a combined pluggable optical transceiver and latch-release sleeve showing our new design;

FIG. 2 is a front view thereof;

FIG. 3 is a back view thereof;

FIG. 4 is a right side view thereof;

FIG. 5 is a left side view thereof;

FIG. 6 is a top view thereof;

FIG. 7 is a bottom view thereof;

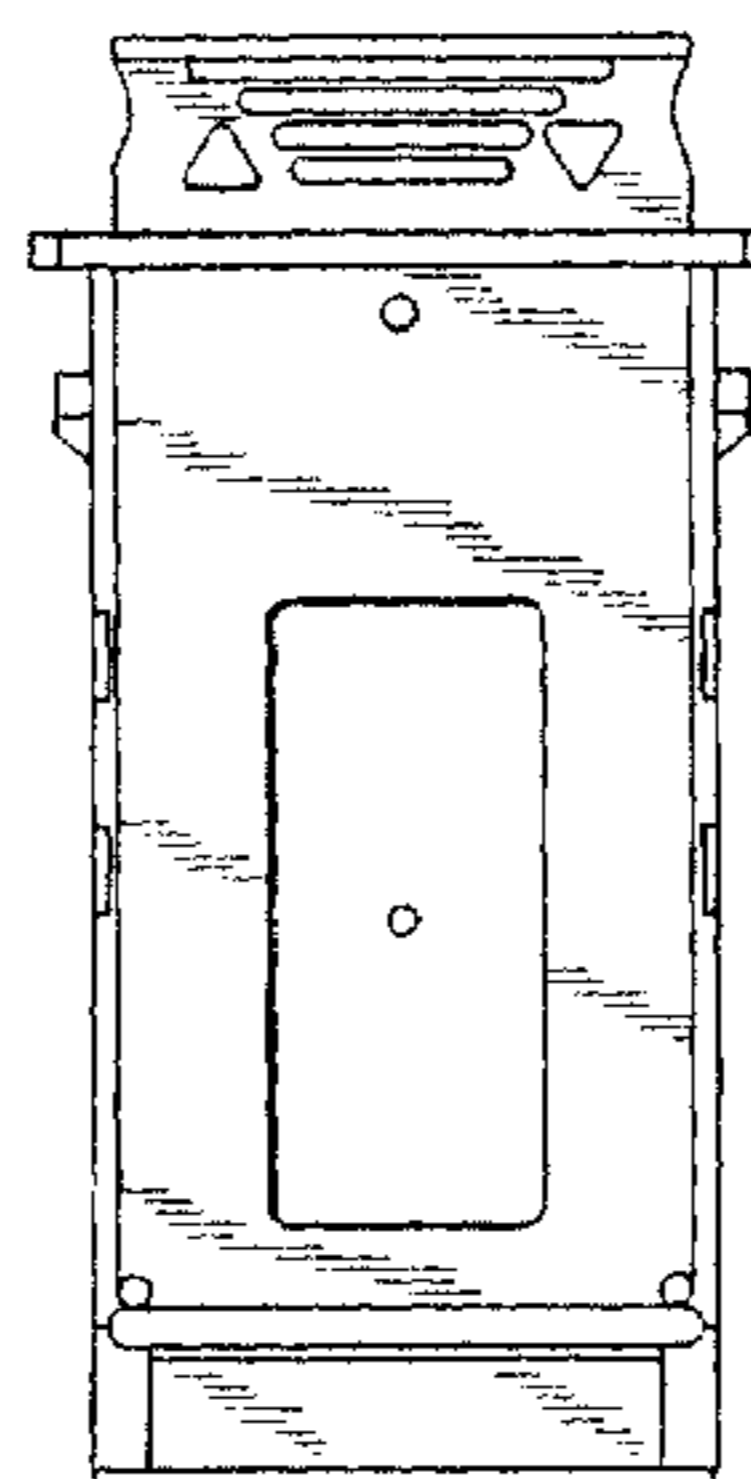

FIG. 8 is an enlarged top, front and right side perspective view of a combined pluggable optical transceiver and latch-release sleeve in a state where a latch is released showing an alternate usage condition;

FIG. 9 is a front view thereof;

FIG. 10 is a back view thereof;

FIG. 11 is a right side view thereof;

FIG. 12 is a left side view thereof;

FIG. 13 is a top view thereof;

FIG. 14 is a bottom view thereof;

FIG. 15 is an enlarged top, front and right perspective view of the latch-release sleeve disassembled from a combined pluggable optical receiver shown separately for clarity;

FIG. 16 is a front view thereof;

FIG. 17 is a back view thereof;

FIG. 18 is a right side view thereof;

FIG. 19 is a left side view thereof;

FIG. 20 is a top view thereof;

FIG. 21 is a bottom view thereof; and,

FIG. 22 is a cross sectional view thereof, taken along line 22—22 in FIG. 21.

In FIGS. 6 and 13, small circles shown at two points on a rear portion of the optical transceiver housing and an outer circle of a double circle shown at one point on a front portion of the optical transceiver housing are holes.

In FIGS. 7 and 14, small circles shown at two points on the rear portion, one point on a front-center portion, and one point on a center portion of the optical transceiver housing are holes. Further, in FIGS. 7 and 14, a rectangular concave portion with a depth of about 0.1 mm is formed at the center portion along a longitudinal direction.

The broken line showing in the figure drawings is included for illustrative purposes only and forms no part of the claimed design.

**1 Claim, 22 Drawing Sheets**

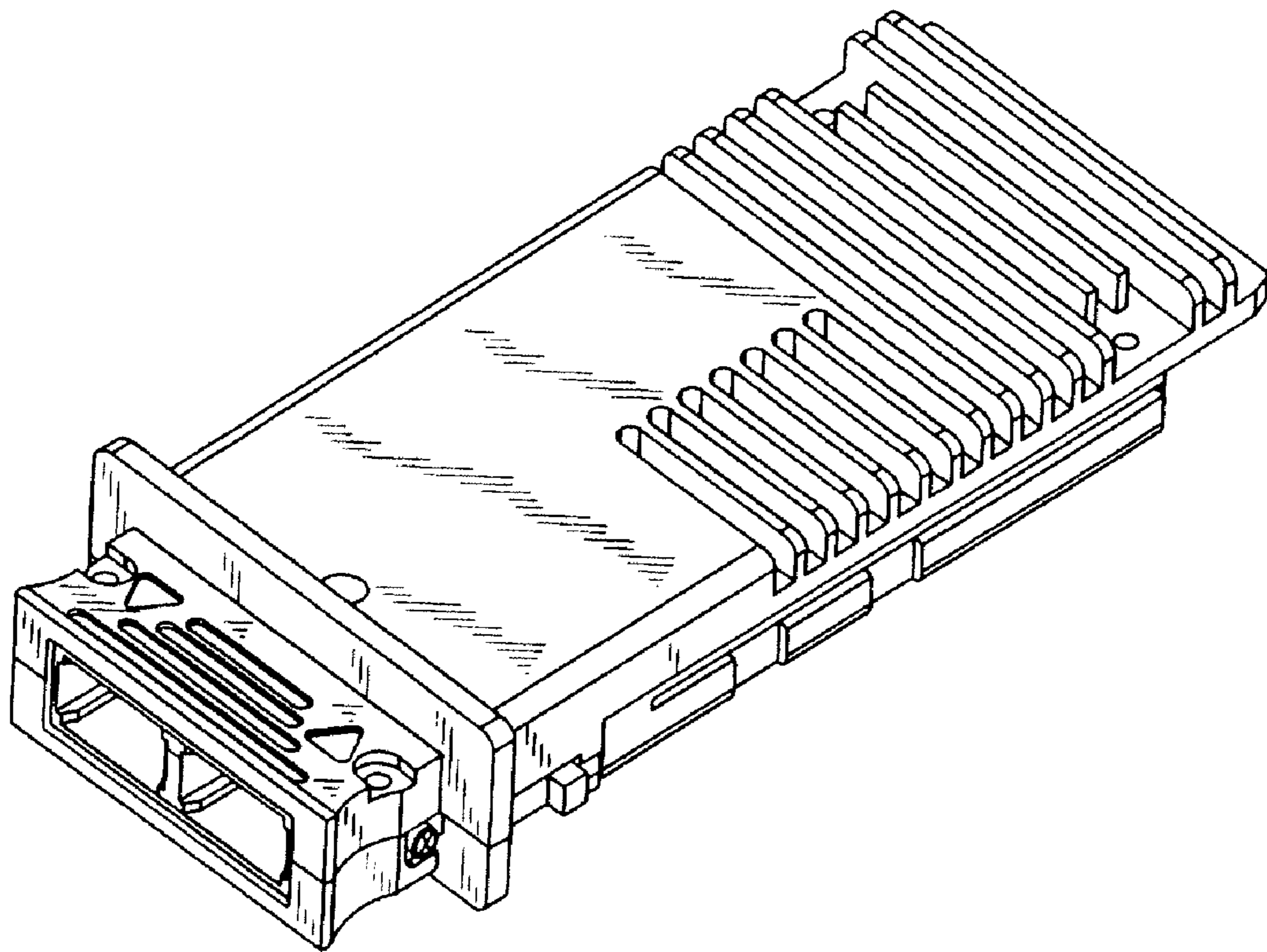
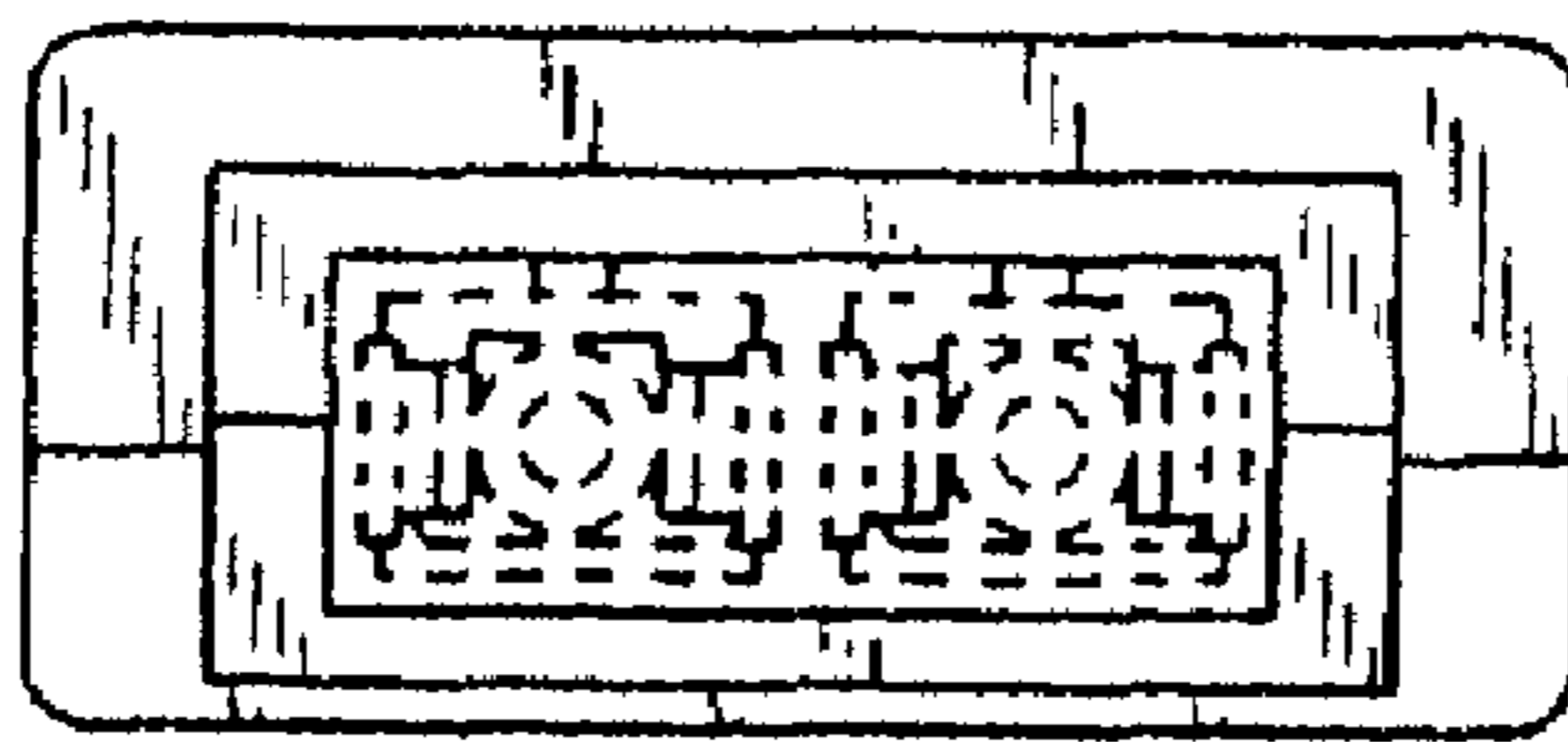
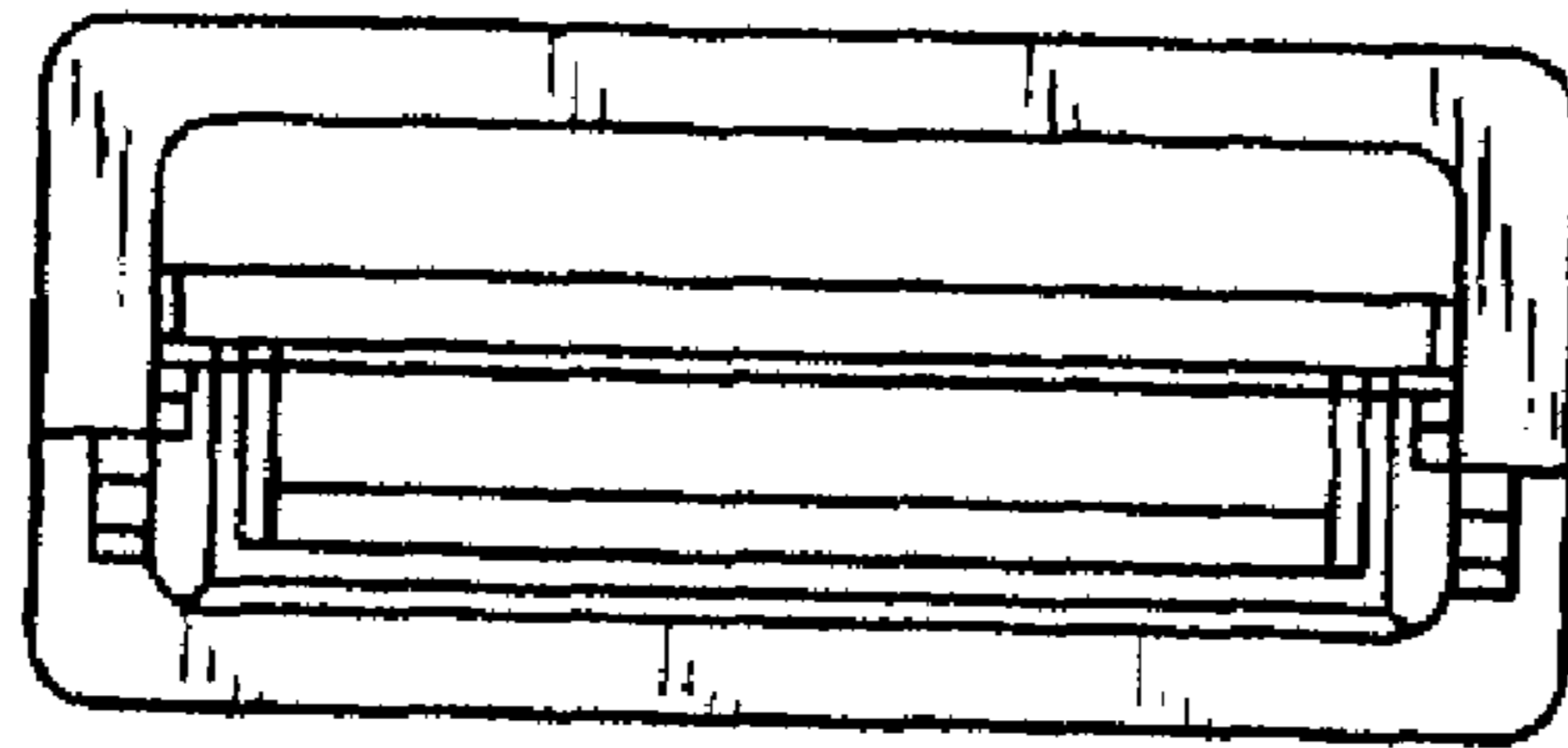

FIG. 1



**FIG. 2**



**FIG. 3**

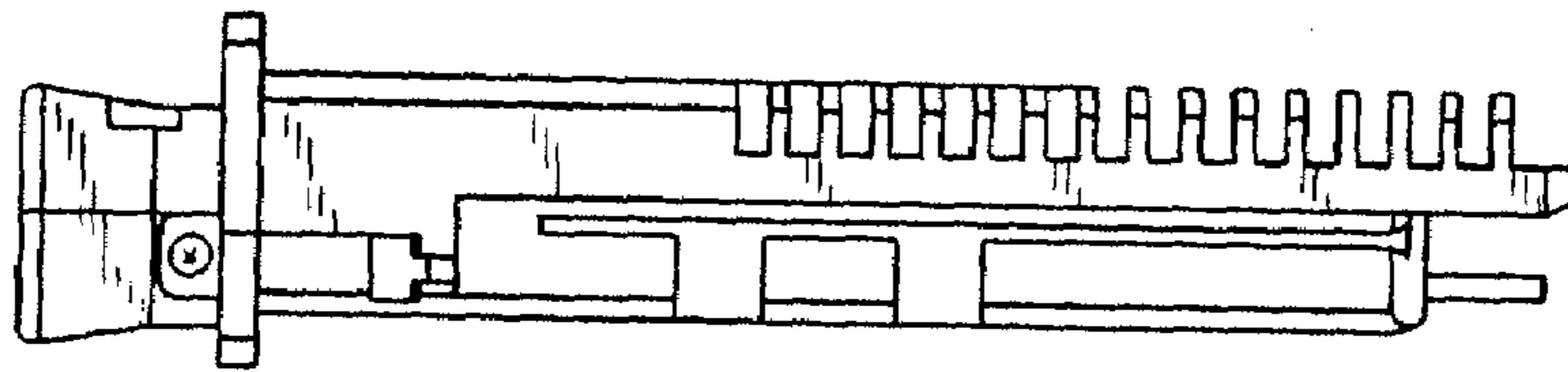

FIG. 4

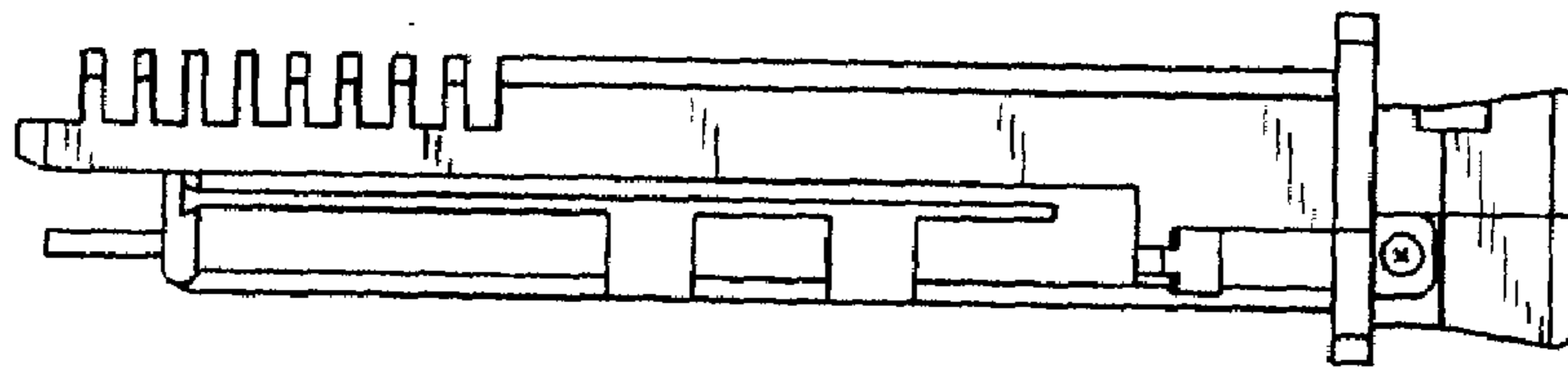

FIG. 5

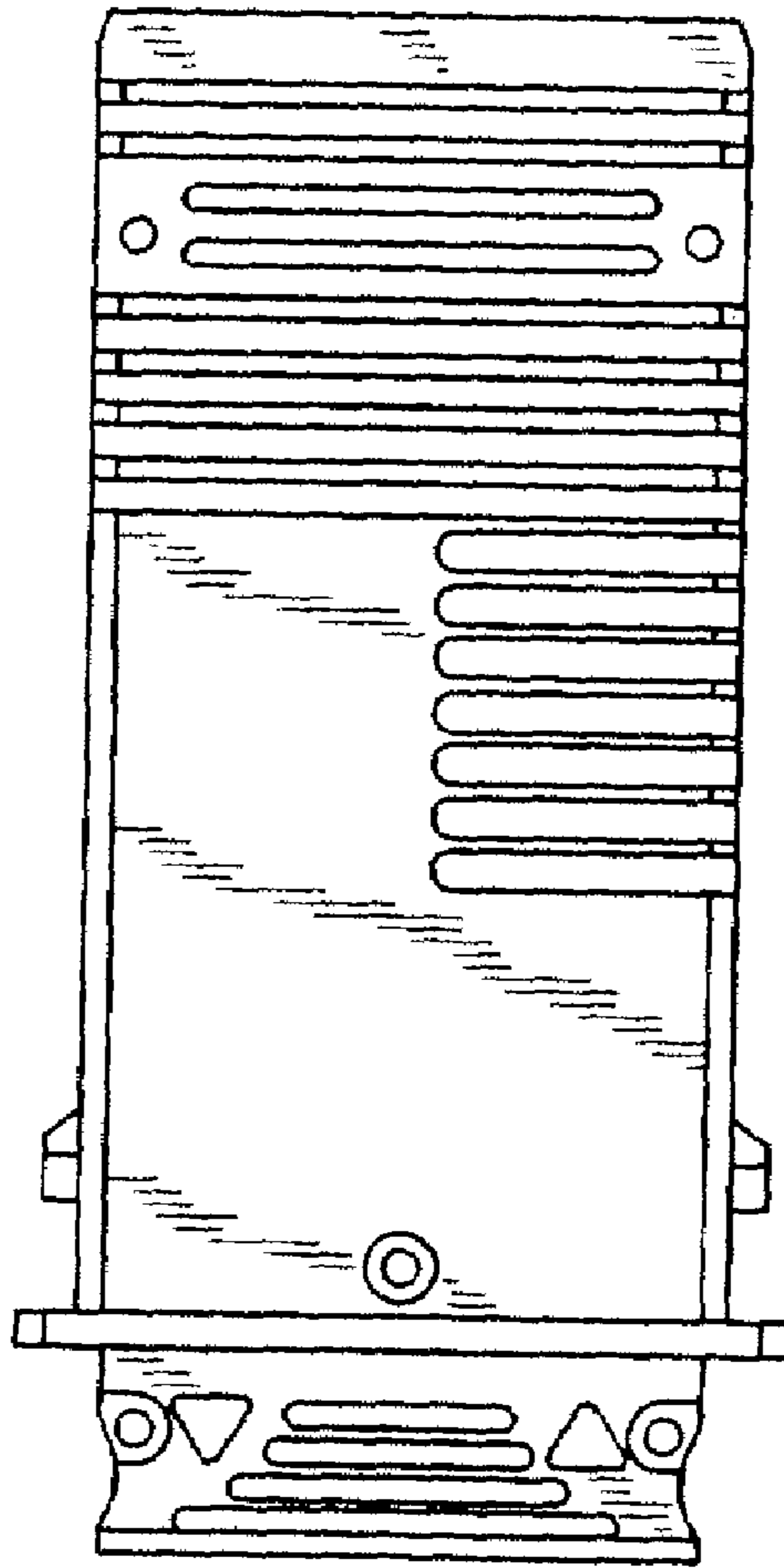

FIG. 6



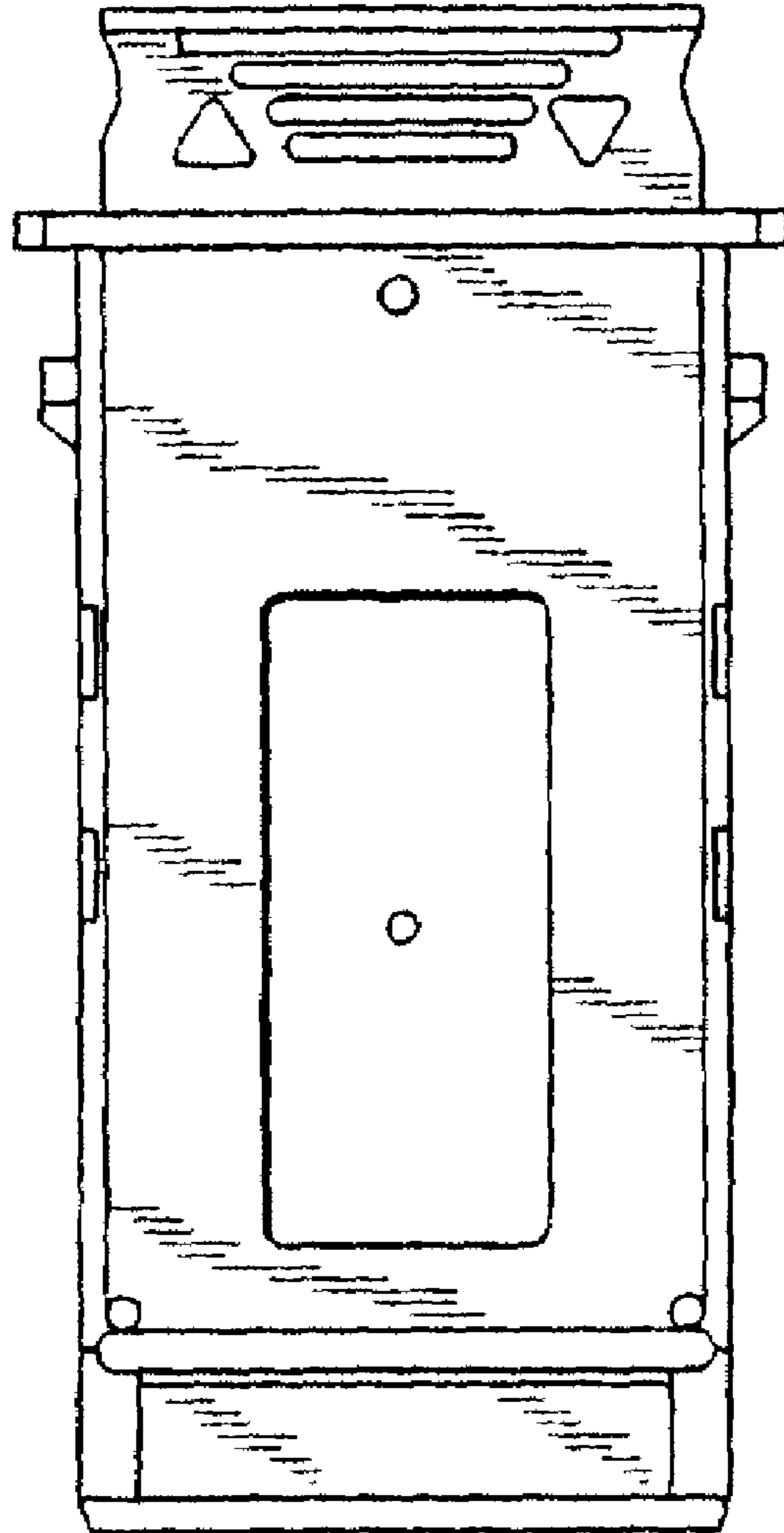

FIG. 7

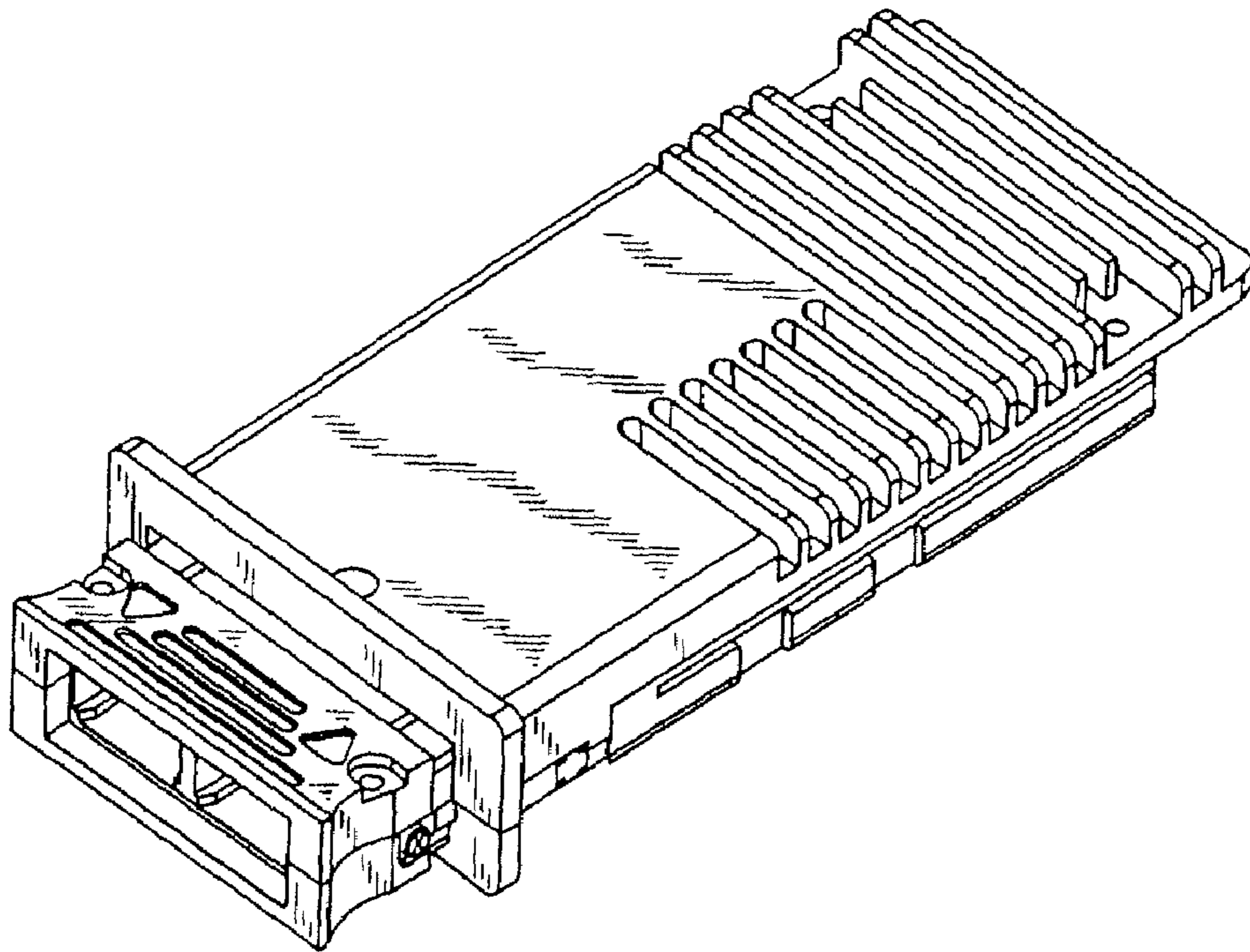
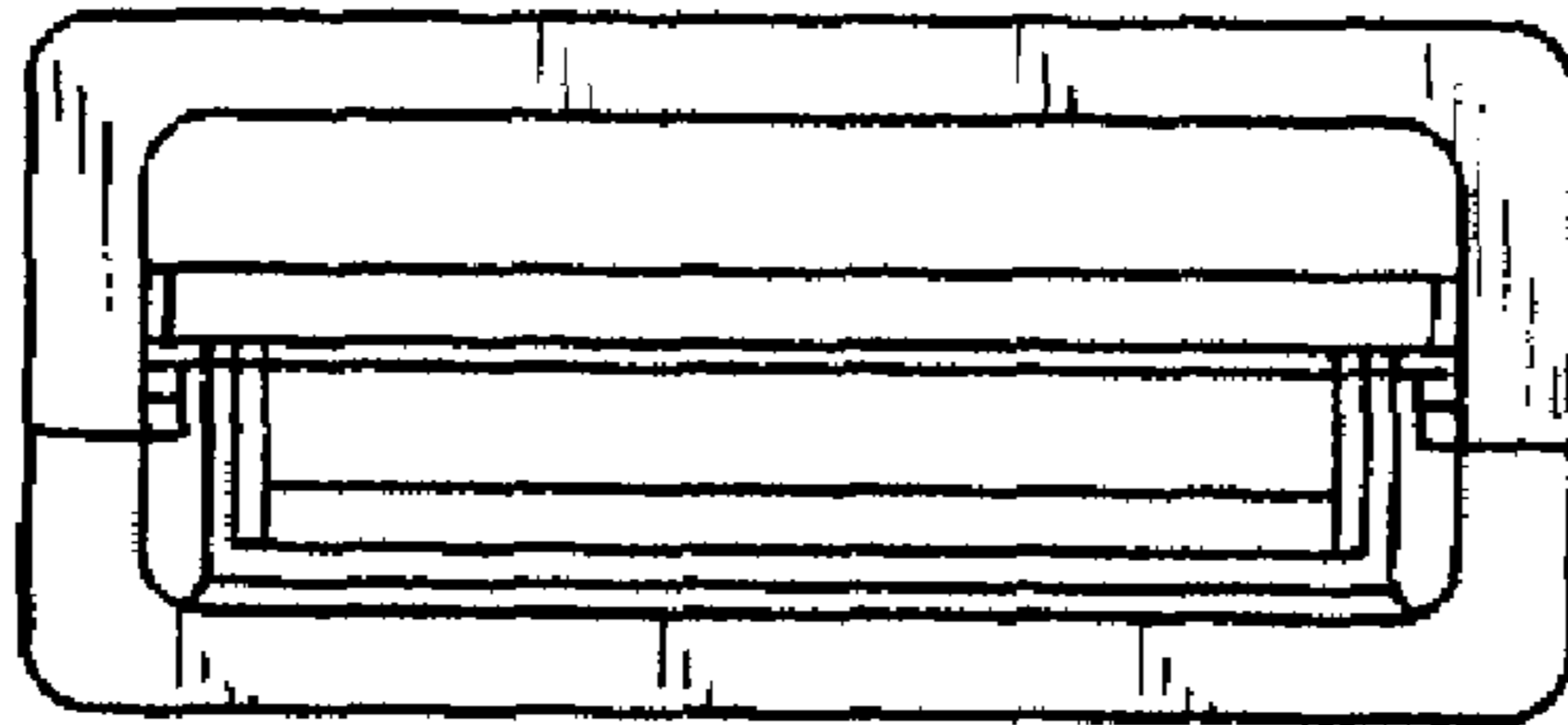

FIG. 8



**FIG. 9**



**FIG. 10**

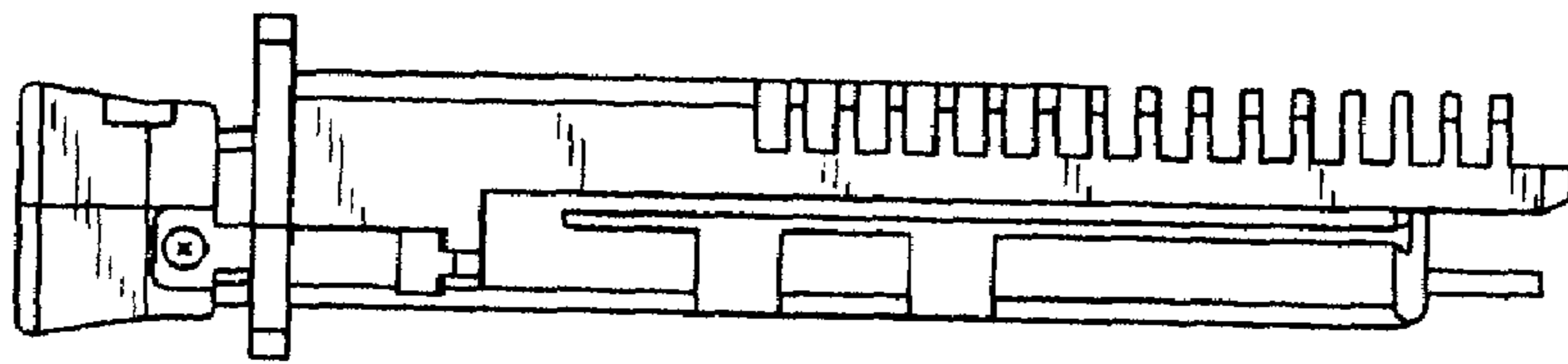

FIG. 11

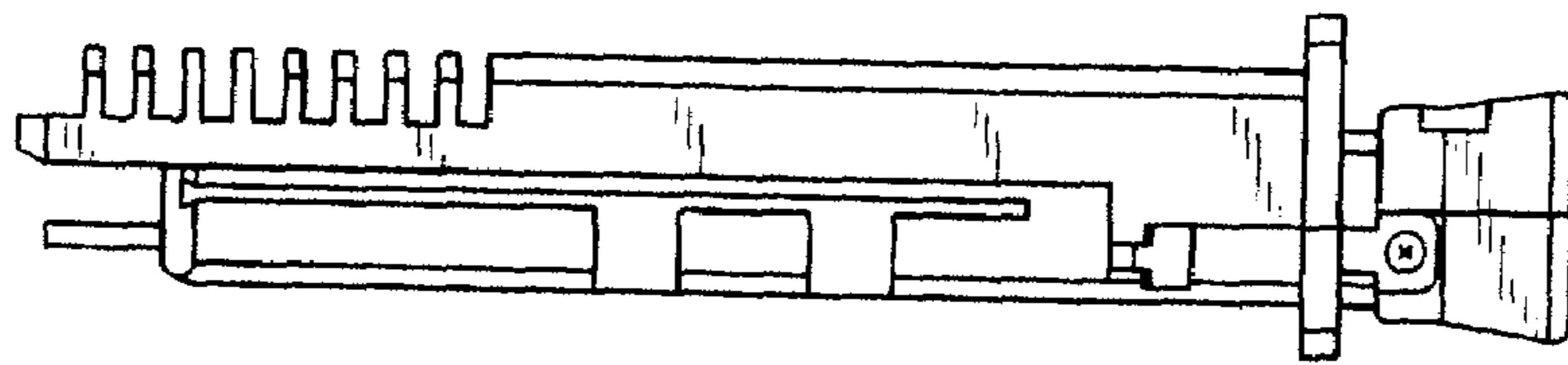

FIG. 12

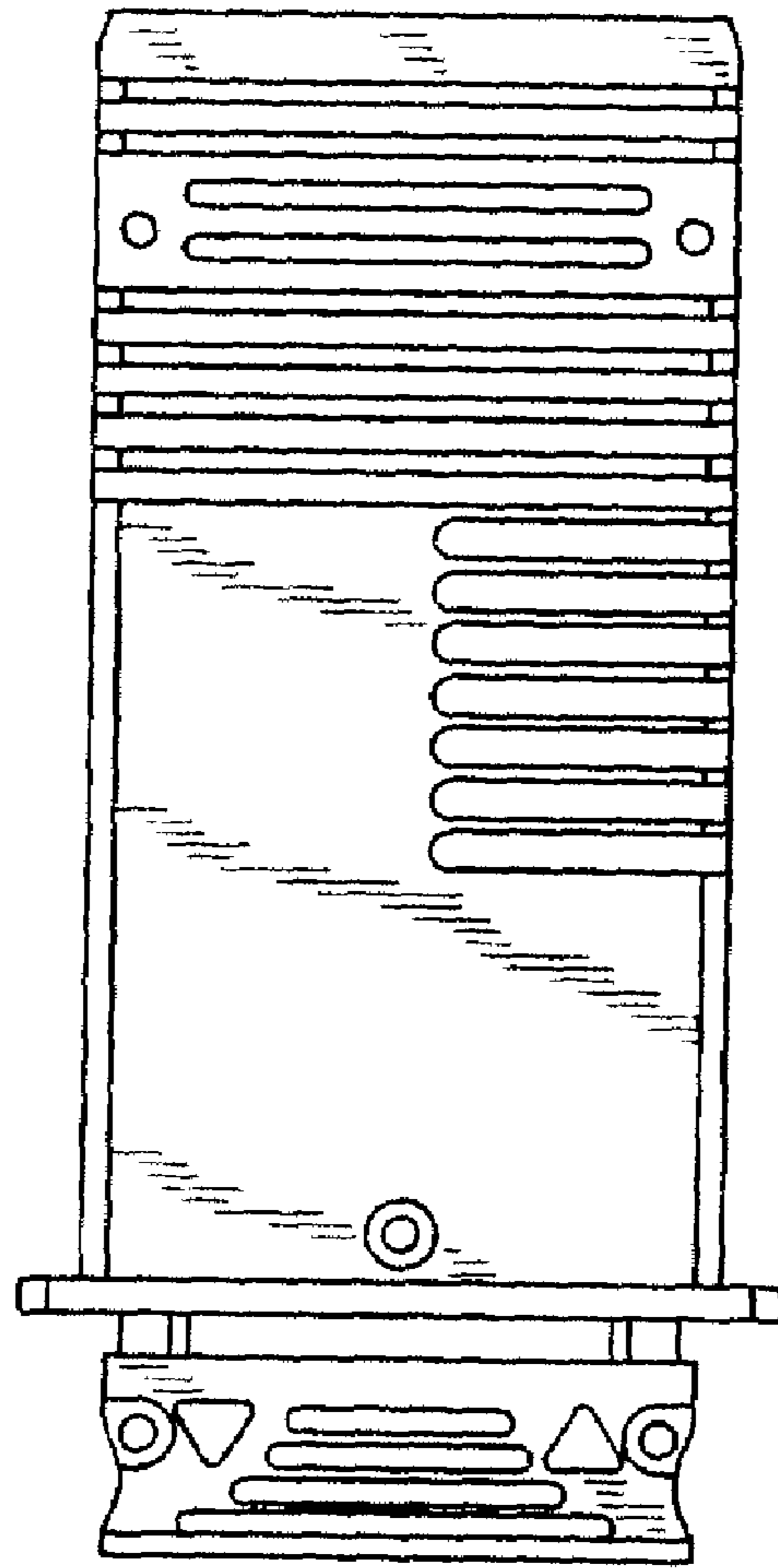
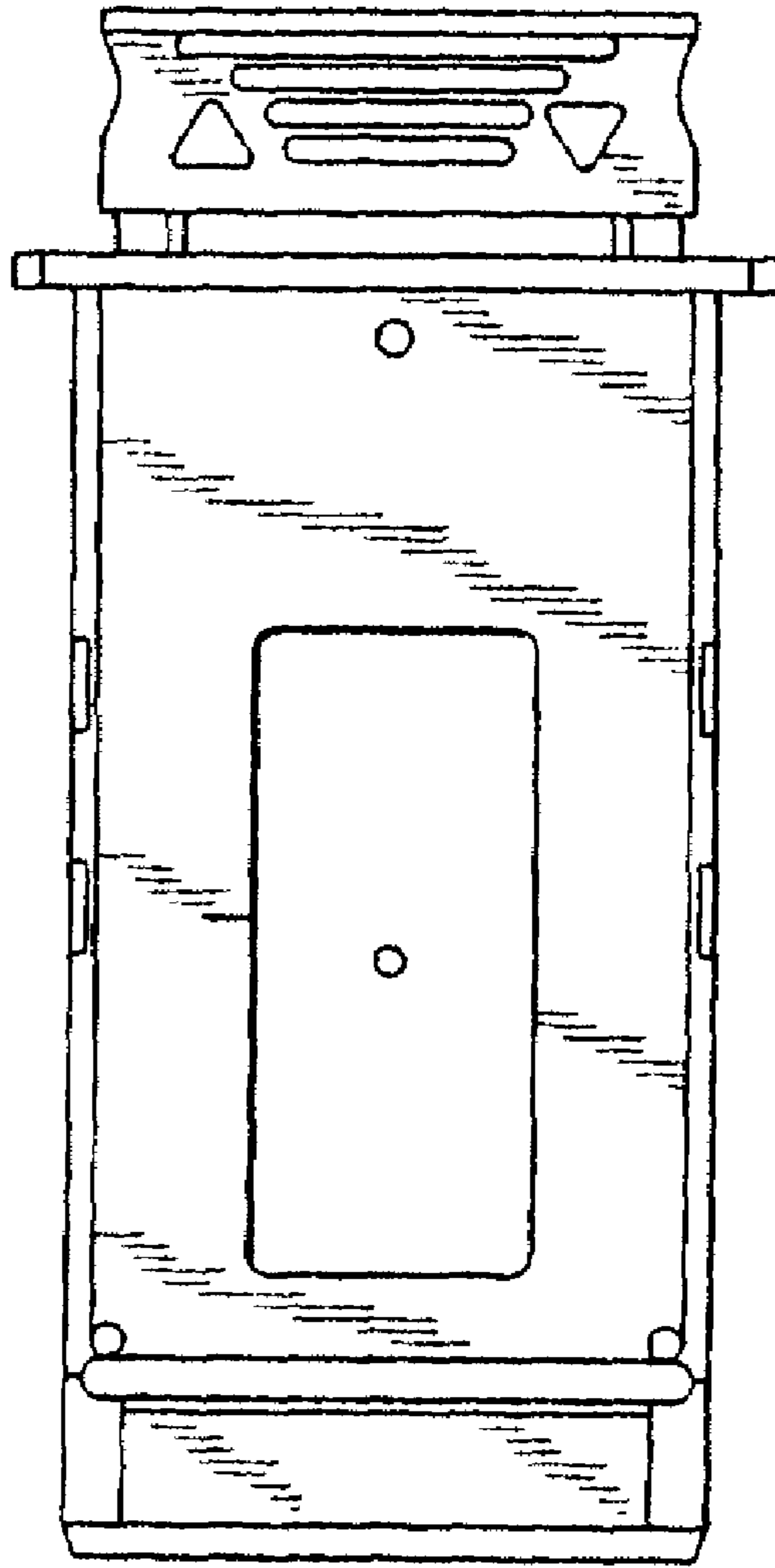
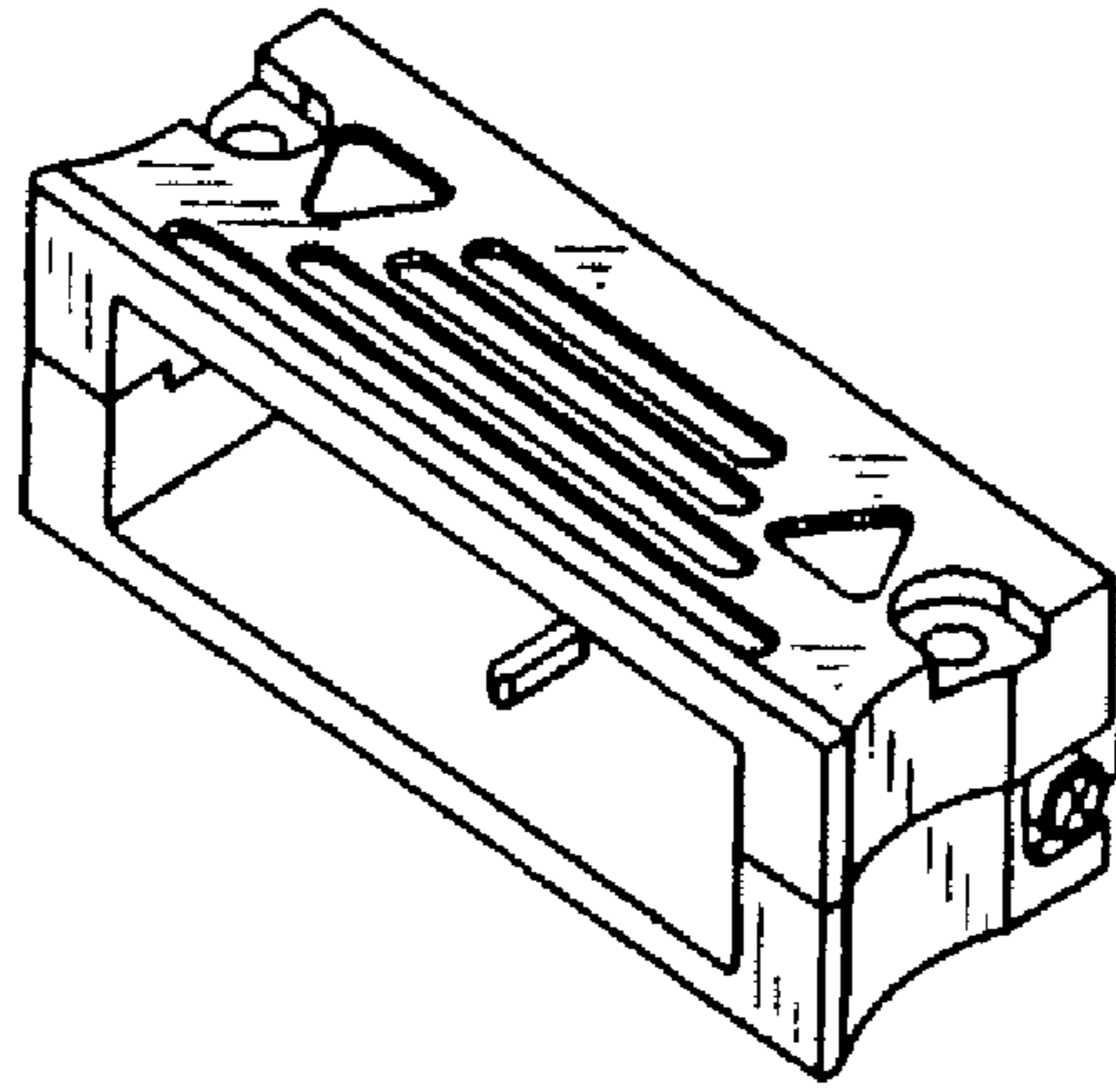

FIG. 13

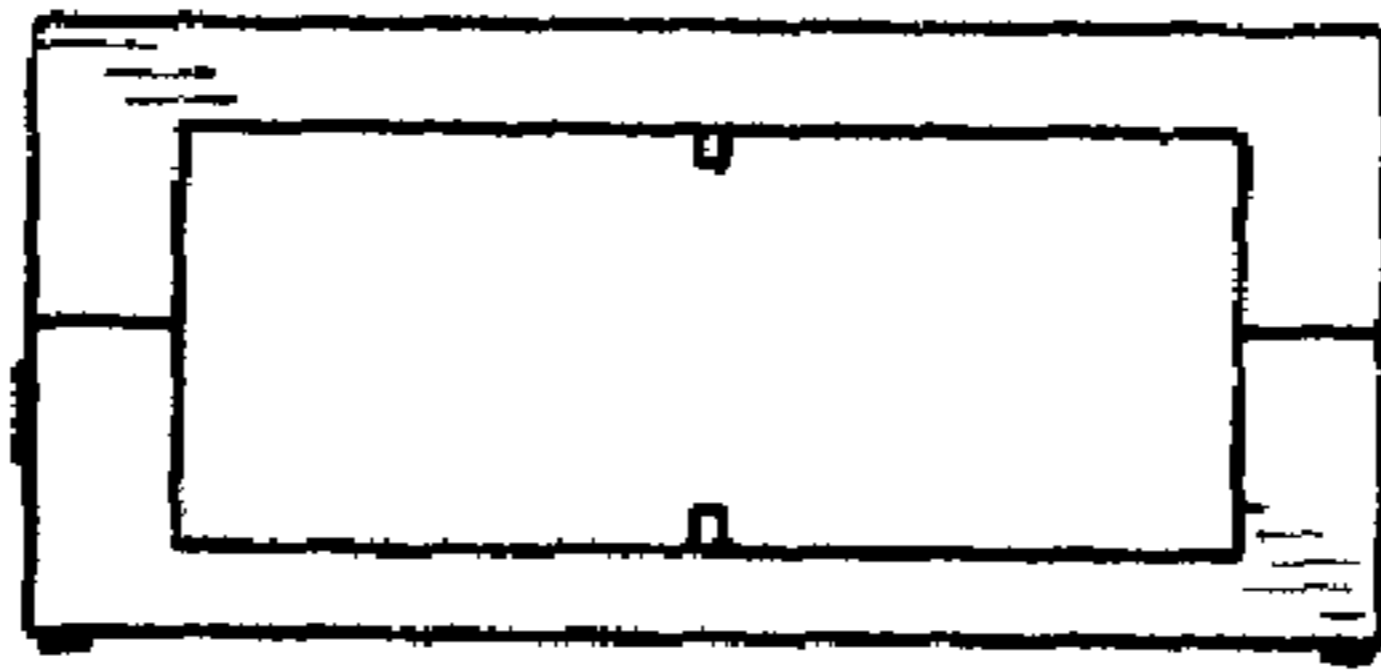

**FIG. 14**

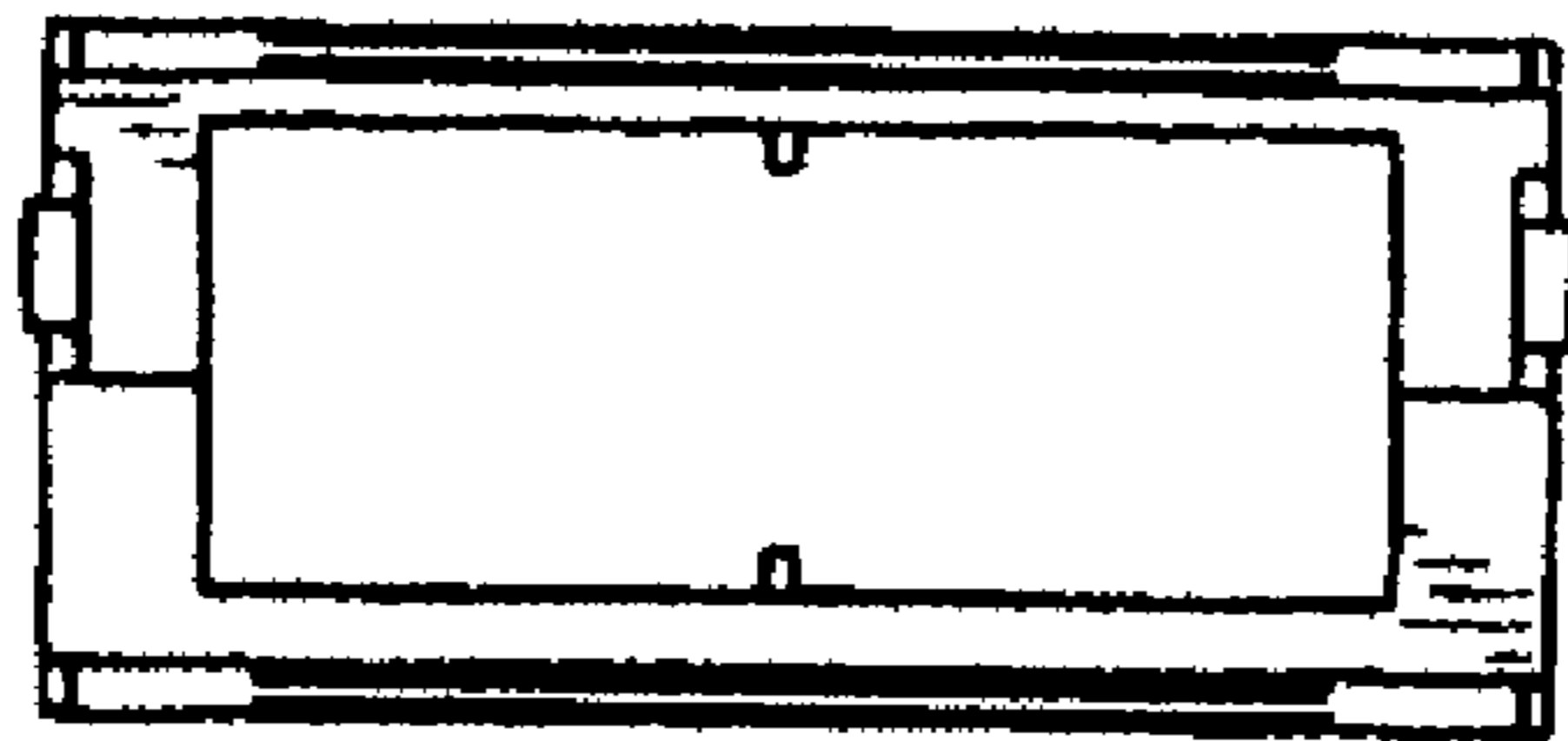



**FIG. 15**



**FIG. 16**



**FIG. 17**

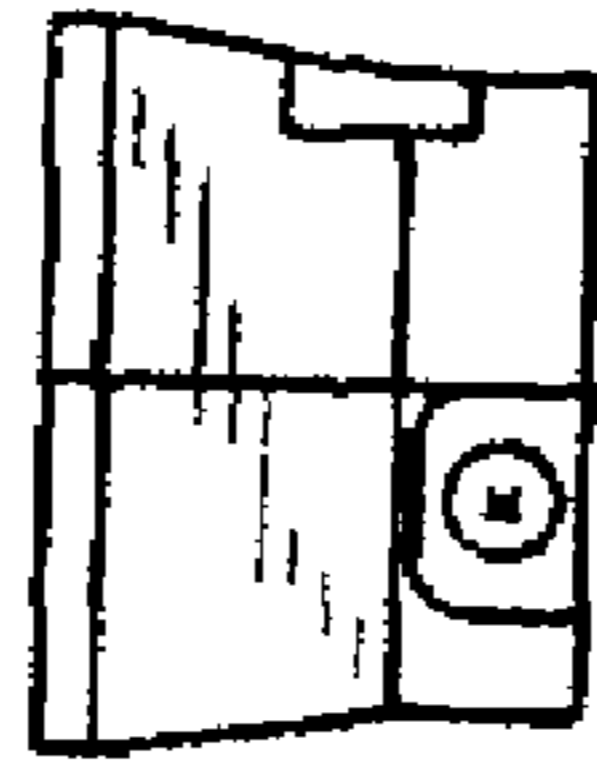

**FIG. 18**

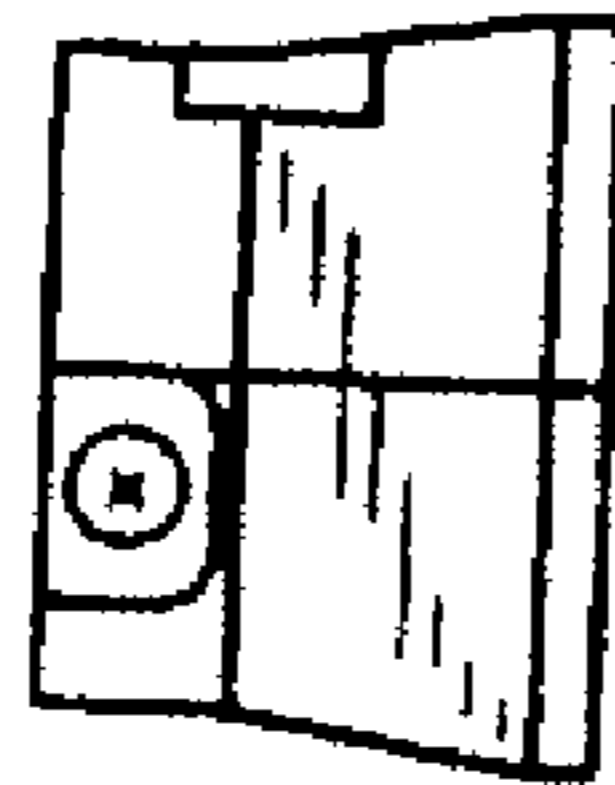

**FIG. 19**

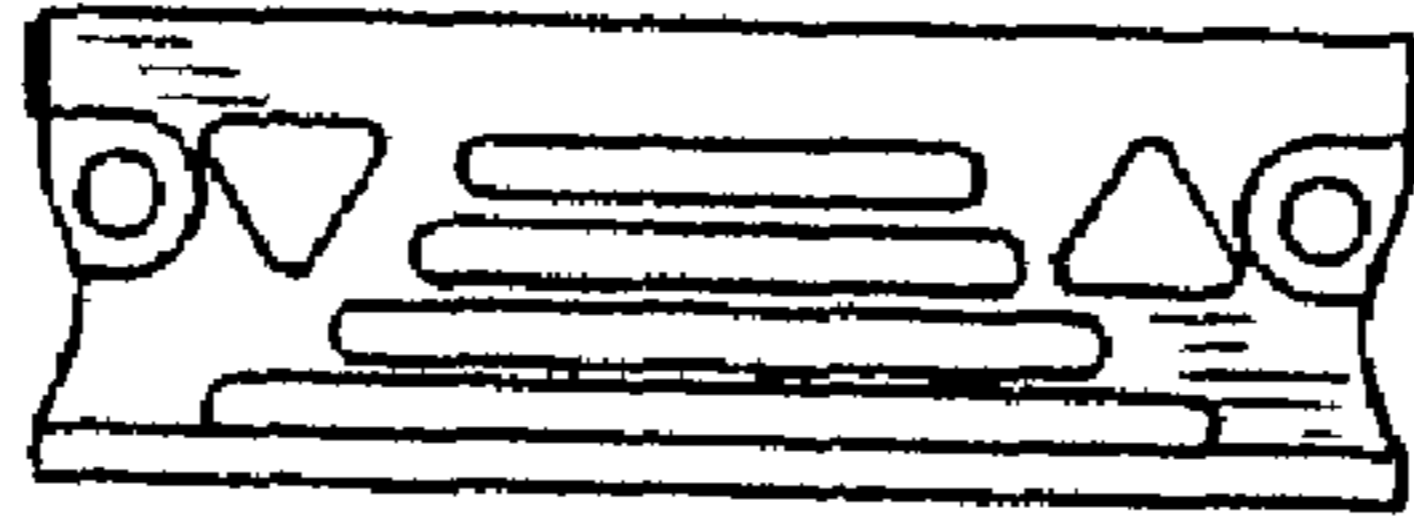

**FIG. 20**

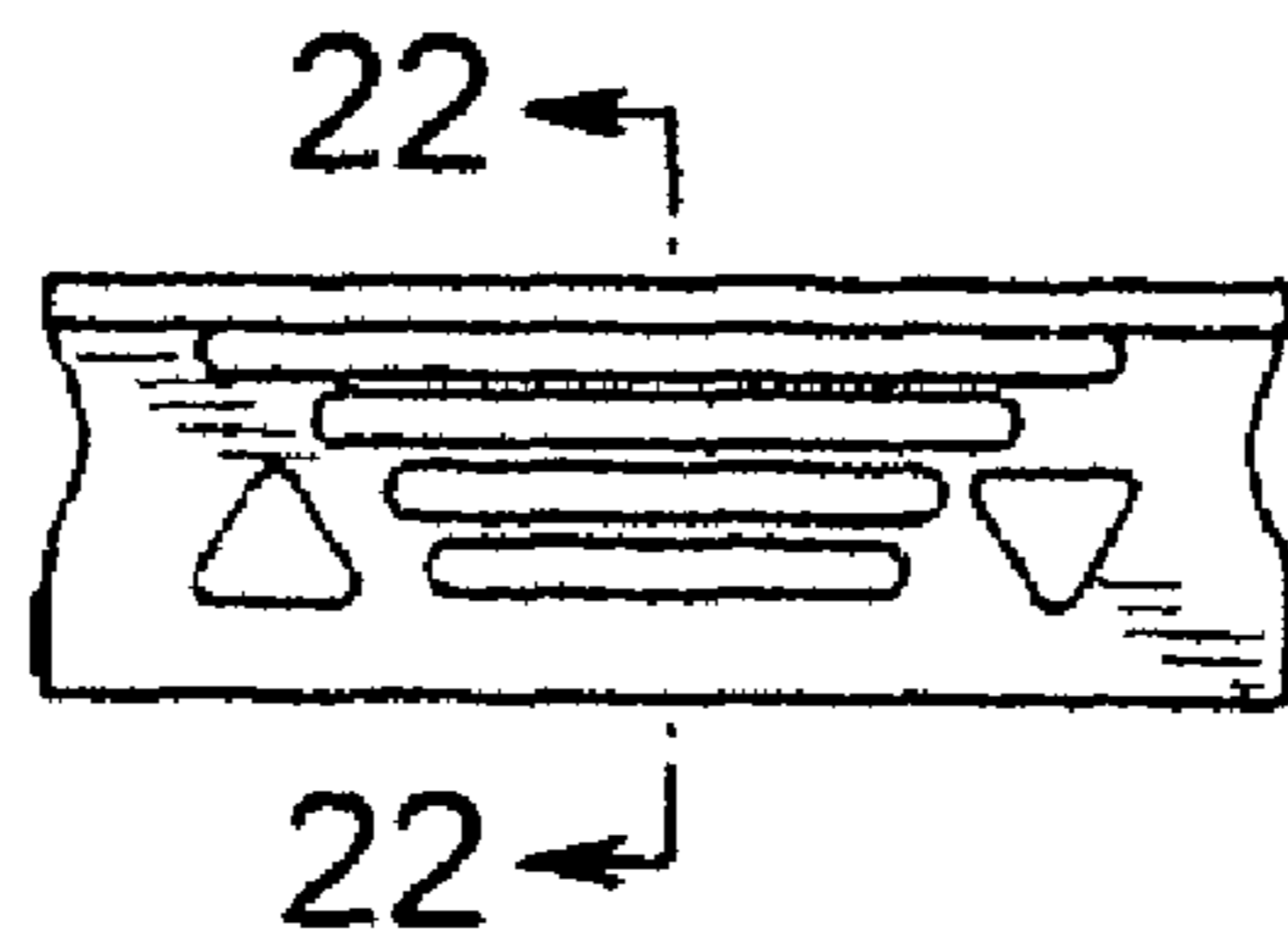

**FIG. 21**

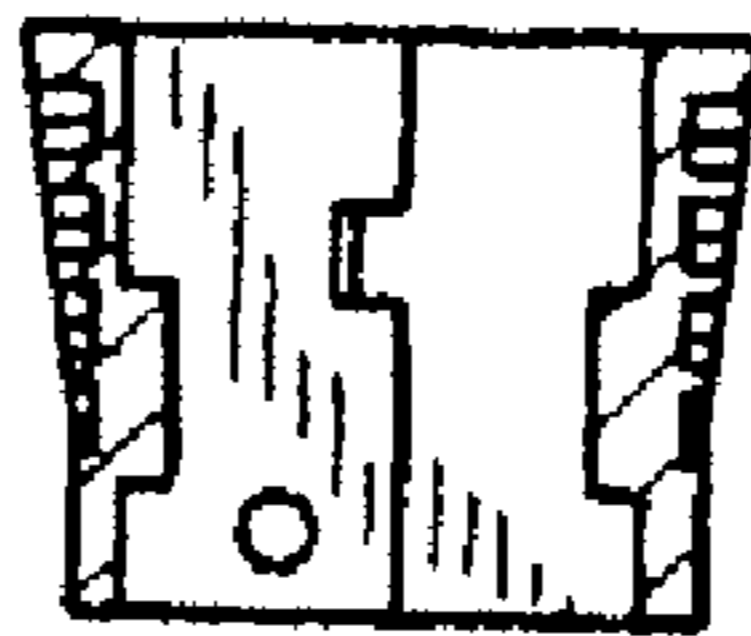

**FIG. 22**