



US00D570618S

(12) **United States Design Patent**
Tai

(10) **Patent No.:** **US D570,618 S**
(45) **Date of Patent:** **** Jun. 10, 2008**

- (54) **SPEAKER STAND**
- (75) Inventor: **Jonathan Tai**, Shanghai (CN)
- (73) Assignee: **Shanghai Max Precision Instrument**,
Shanghai (CN)
- (**) Term: **14 Years**
- (21) Appl. No.: **29/247,761**
- (22) Filed: **Jul. 10, 2006**
- (51) **LOC (8) Cl.** **06-06**
- (52) **U.S. Cl.** **D6/431**
- (58) **Field of Classification Search** D6/431,
D6/449, 455, 457, 466, 474, 486; D14/204,
D14/211, 221, 224, 451; D24/128; D8/373;
181/198–199; 248/346.01, 676
See application file for complete search history.

(56) **References Cited**
U.S. PATENT DOCUMENTS

| | | | |
|---------------|---------|---------------|-----------------|
| 230,851 A | 8/1880 | Anthony | |
| 368,426 A | 8/1887 | Rutmann | |
| 730,062 A | 6/1903 | Widmer | |
| D47,742 S * | 8/1915 | Smith | D6/431 |
| 1,359,811 A | 11/1920 | Kirkendall | |
| 1,684,912 A | 9/1928 | Dunklau | |
| 1,862,562 A | 6/1932 | Aldeen et al. | |
| 1,863,756 A | 6/1932 | Lufkin | |
| 2,547,924 A | 4/1951 | Citro | |
| 2,559,200 A | 7/1951 | Schaf | |
| 2,579,348 A * | 12/1951 | Taylor | 248/178.1 |
| 2,630,289 A | 3/1953 | Selig | |
| 2,727,708 A | 12/1955 | Lorenzen | |
| 2,940,709 A | 6/1960 | Neuwirth | |
| 3,057,591 A | 10/1962 | Weimer | |
| 3,526,380 A | 9/1970 | Tong | |
| D223,638 S | 5/1972 | Smith | |
| 3,709,454 A | 1/1973 | Hyde | |
| 3,804,355 A | 4/1974 | Uroshevich | |
| 3,881,675 A | 5/1975 | Matchett | |
| D236,227 S | 8/1975 | Kester, Jr. | |
| 4,010,922 A | 3/1977 | Heller | |
| 4,061,302 A | 12/1977 | Boone | |

| | | | |
|---------------|---------|----------------------|---------------|
| D260,816 S * | 9/1981 | Zissimopoulos et al. | ... D24/128 |
| 4,317,552 A | 3/1982 | Weidler | |
| 4,378,100 A * | 3/1983 | Minozzi et al. | 248/168 |
| D268,458 S * | 4/1983 | Schoenig | D6/431 |
| 4,561,339 A | 12/1985 | Jensen | |
| 4,582,282 A | 4/1986 | Gracie | |
| 4,671,479 A | 6/1987 | Johnson | |
| 4,691,610 A | 9/1987 | Gilbert | |
| 4,693,161 A | 9/1987 | Uhrig | |
| 4,695,021 A | 9/1987 | Leinfelder | |
| D293,052 S * | 12/1987 | Handler et al. | D6/431 |
| 4,712,756 A | 12/1987 | Kester | |
| 4,744,536 A | 5/1988 | Bancalari | |

(Continued)

OTHER PUBLICATIONS

Ultimate Support Systems, Inc. Product Catalog 2004; Fort Collins, Colorado.

(Continued)

Primary Examiner—Caron D. Veynar
Assistant Examiner—Abraham Bahta
(74) *Attorney, Agent, or Firm*—William W. Cochran;
Cochran Freund & Young LLC

(57) **CLAIM**

The ornamental design for a speaker stand, as shown and described.

DESCRIPTION

FIG. 1 is an isometric view of a speaker stand showing my new design.
FIG. 2 is a front view thereof.
FIG. 3 is a top view thereof.
FIG. 4 is a right side view thereof.
FIG. 5 is a left side view thereof.
FIG. 6 is a rear view thereof; and,
FIG. 7 is a bottom view thereof.

1 Claim, 7 Drawing Sheets

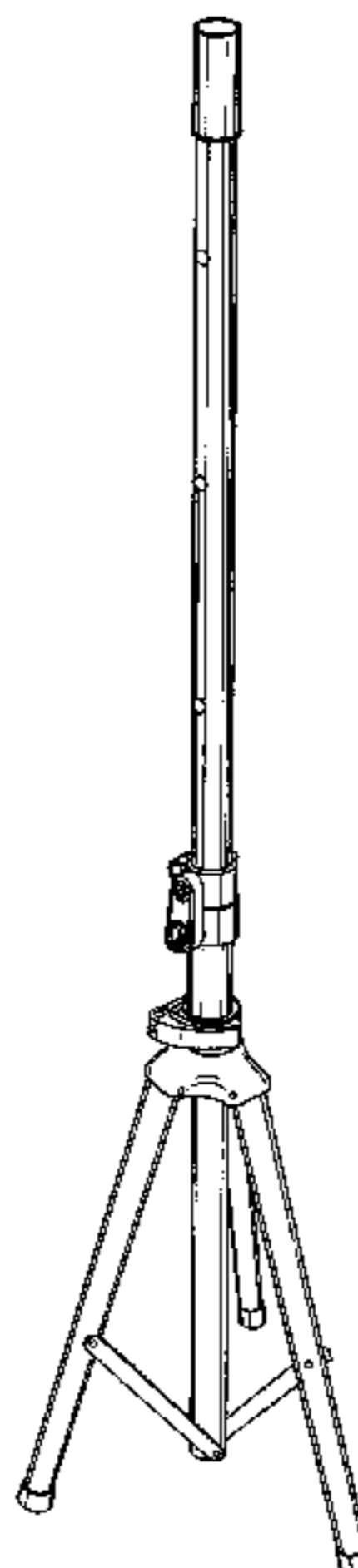

US D570,618 S

U.S. PATENT DOCUMENTS

| | | | | | | |
|---------------|---------|-----------------------------|--|-----------------|---------|------------------------------|
| D299,244 S | 1/1989 | Jones | | D421,447 S | 3/2000 | Eason |
| 4,807,837 A | 2/1989 | Gawlik | | 6,036,159 A | 3/2000 | Yu |
| 4,923,156 A | 5/1990 | Linneusson | | 6,108,194 A * | 8/2000 | Seligman et al. 361/600 |
| 5,037,057 A | 8/1991 | Andrews | | 6,113,040 A | 9/2000 | Yu |
| 5,060,894 A | 10/1991 | Hillinger | | 6,127,612 A | 10/2000 | Yu |
| 5,114,111 A | 5/1992 | Andrews | | D435,365 S | 12/2000 | Eason |
| 5,165,635 A | 11/1992 | Hoshino | | 6,209,829 B1 | 4/2001 | Yu |
| D332,882 S | 2/1993 | Graves | | 6,283,421 B1 | 9/2001 | Eason |
| 5,197,701 A | 3/1993 | Olson | | 6,322,027 B1 * | 11/2001 | Hsu 248/177.1 |
| 5,213,296 A | 5/1993 | Lee | | 6,323,405 B1 | 11/2001 | Yu |
| 5,267,712 A * | 12/1993 | Shen 248/179.1 | | 6,375,135 B1 | 4/2002 | Eason |
| 5,340,066 A | 8/1994 | Ditch | | 6,439,532 B1 | 8/2002 | Yu |
| 5,350,143 A | 9/1994 | Hoshino | | 6,513,768 B1 | 2/2003 | Hsieh |
| D353,729 S | 12/1994 | MacOwan | | 6,682,042 B2 | 1/2004 | Anderson |
| 5,375,497 A | 12/1994 | Pirchio | | D490,289 S * | 5/2004 | Chuang D8/72 |
| 5,383,634 A | 1/1995 | Liao | | D540,564 S * | 4/2007 | Tai D6/419 |
| D356,901 S * | 4/1995 | Schoenig et al. D6/400 | | 2002/0070319 A1 | 6/2002 | Yu |
| D357,828 S | 5/1995 | Liao | | 2002/0088914 A1 | 7/2002 | Yu |
| 5,454,473 A | 10/1995 | Hennessey | | | | |
| 5,505,413 A | 4/1996 | Hennessey | | | | |
| 5,564,661 A * | 10/1996 | Gershon 248/167 | | | | |
| 5,664,756 A | 9/1997 | Liao | | | | |
| 5,692,719 A | 12/1997 | Shepherd | | | | |
| 5,713,547 A | 2/1998 | Yu | | | | |
| D392,123 S | 3/1998 | Lynch | | | | |
| 5,726,369 A | 3/1998 | Gilday | | | | |
| D394,764 S | 6/1998 | Nordstrom | | | | |
| D408,179 S | 4/1999 | Rellinger | | | | |
| 5,934,628 A | 8/1999 | Bosnakovic | | | | |
| 5,957,417 A | 9/1999 | Yu | | | | |
| 5,959,225 A | 9/1999 | Hsu | | | | |
| D414,962 S | 10/1999 | Welsh | | | | |
| 6,005,176 A | 12/1999 | Yu | | | | |

OTHER PUBLICATIONS

Hamilton Orchestra Music Stands Brochure; Hamilton Stands Incorporated; Middletown, Ohio.
 Hamilton School and Orchestra Stands, Conductors' Stands; Folding Stands, Instrument Stands Brochure; Hamilton Stands Incorporated.
http://www.hamiltonstands.com/speaker_stands_and_capos.htm;
 Hamilton Stands, Inc., Middleton, Ohio.
<http://www.herculesstands.com/speakers/speakerstands.html>;
 Hercules Stands.
<http://www.activemusician.com/store/search.asp?qu=speaker+stand&m=0>; ActiveMusician.com.
<http://www.zzounds.com/cat—Speaker-Stands—3811>.
<http://www.samash.com/catalog/search.asp>; SamAsh.com.

* cited by examiner

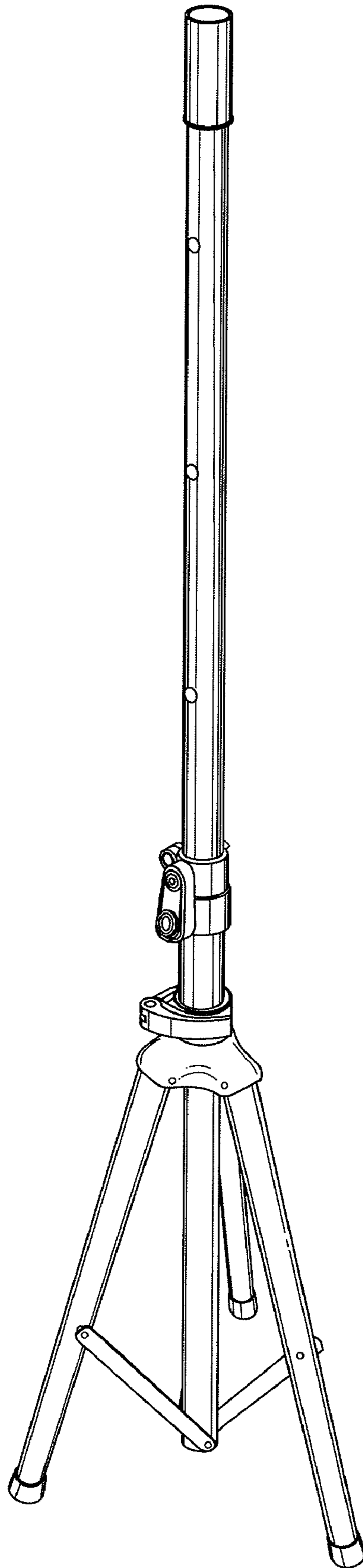

FIG. 1

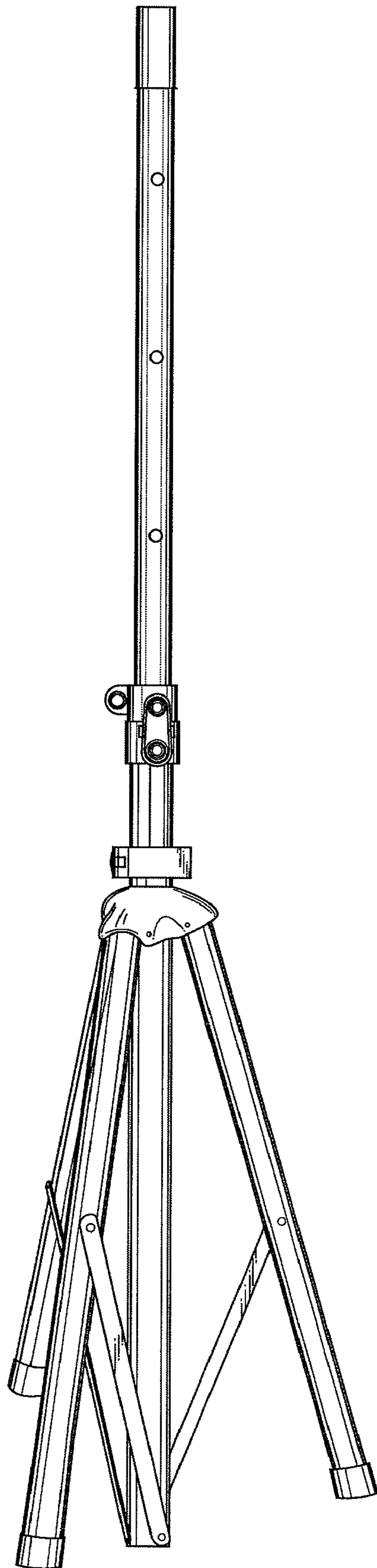

FIG. 2

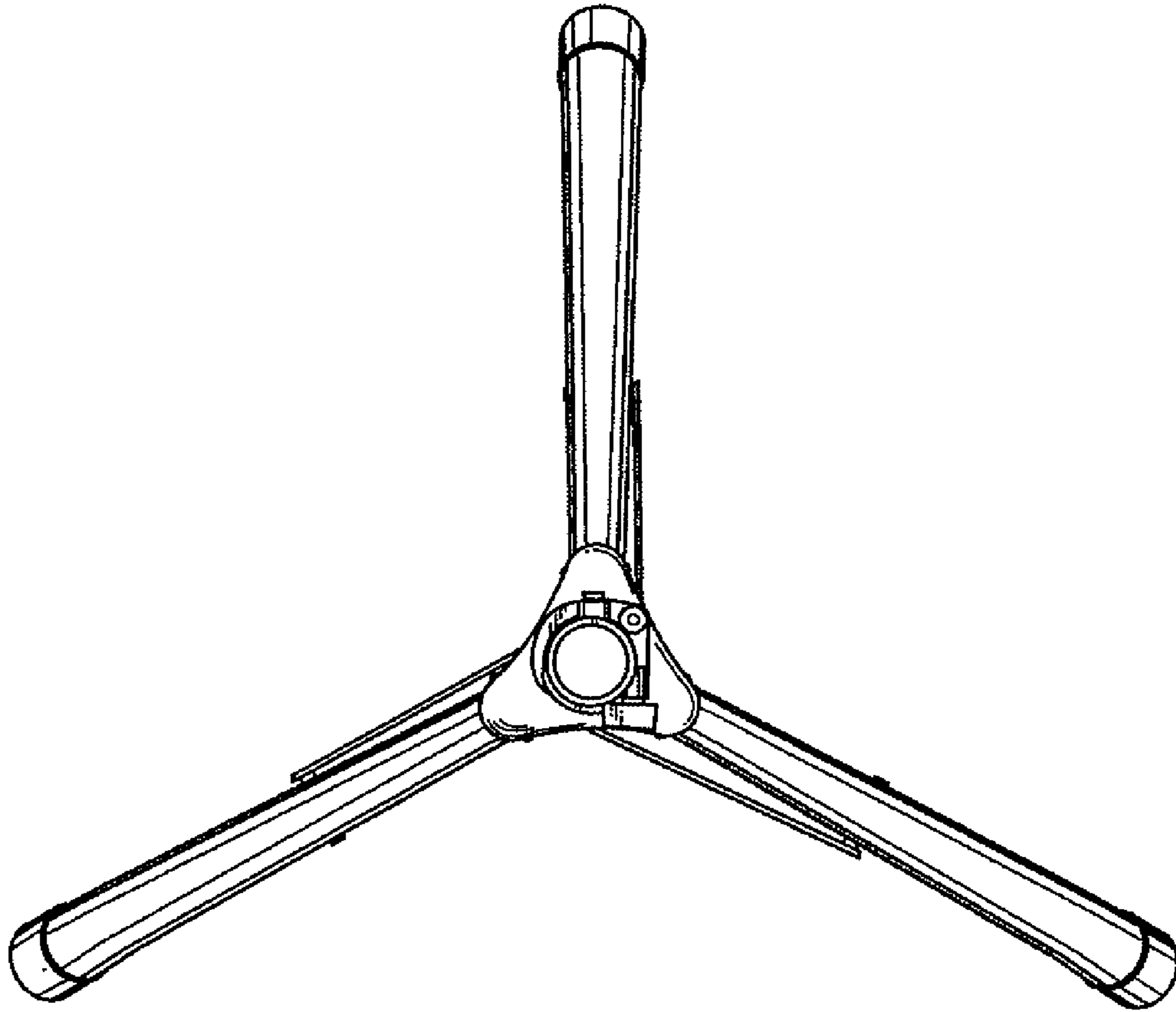

FIG. 3

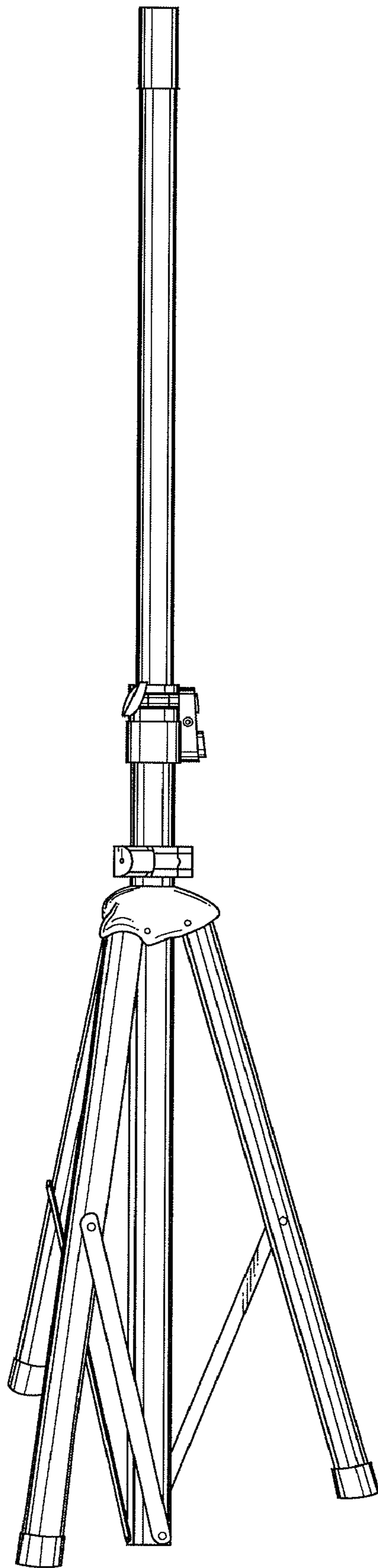

FIG. 4

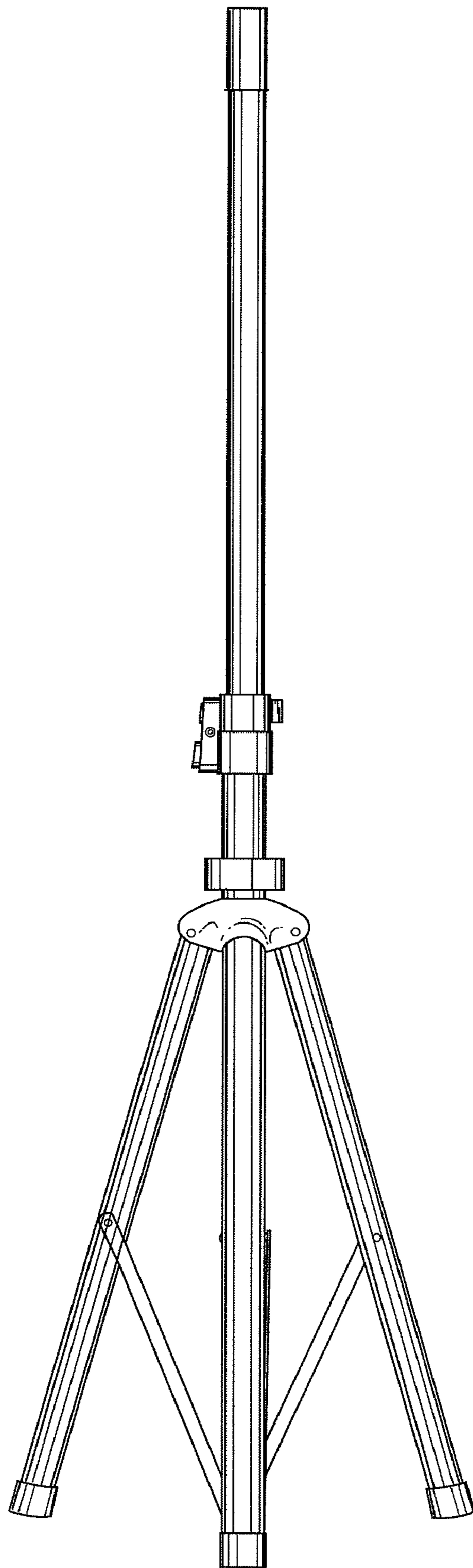

FIG. 5

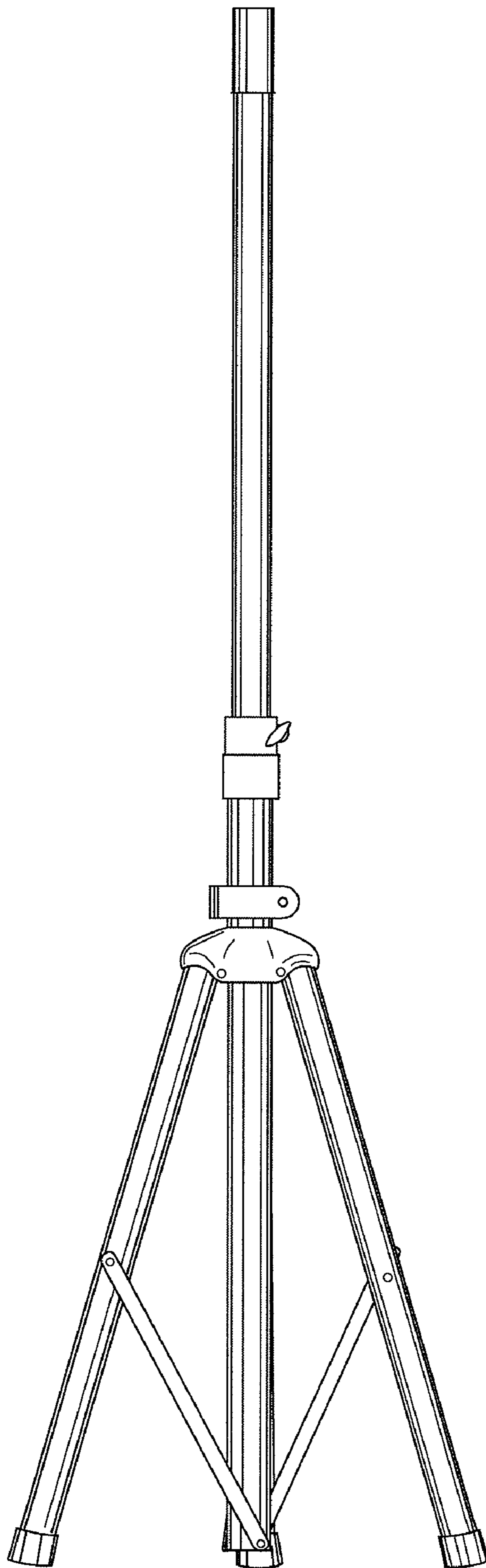

FIG. 6

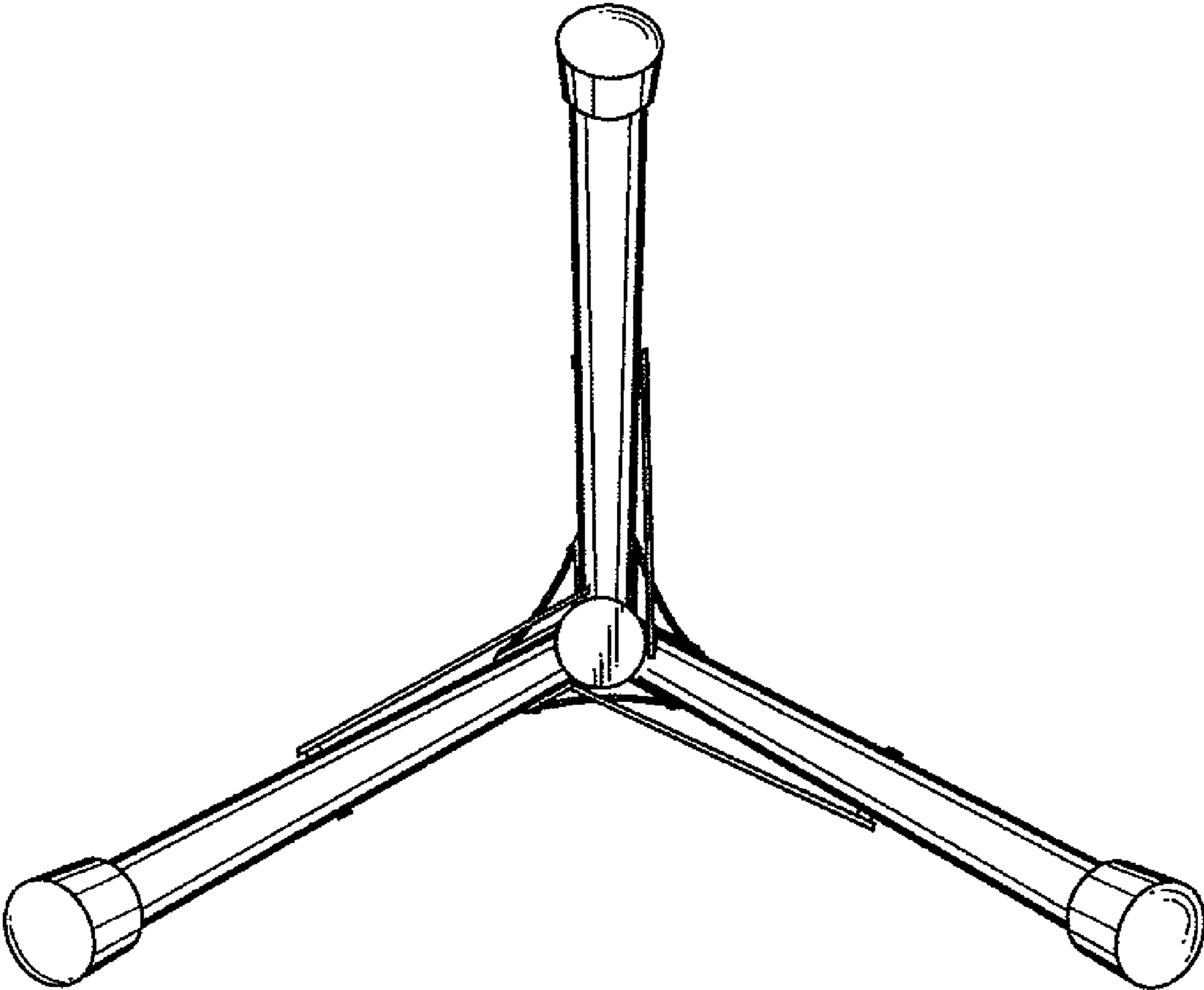

FIG. 7