



US00D570484S

(12) **United States Design Patent**  
**Kaneko et al.**

(10) **Patent No.:** **US D570,484 S**  
(45) **Date of Patent:** **\*\* Jun. 3, 2008**

- (54) **RADIATION THERAPY DEVICE**
- (75) Inventors: **Shuji Kaneko**, Hiroshima (JP); **Hiroshi Muraoka**, Kyoto (JP)
- (73) Assignee: **Mitsubishi Heavy Industries, Ltd.**, Tokyo (JP)
- (\*\*) Term: **14 Years**
- (21) Appl. No.: **29/271,034**
- (22) Filed: **Jan. 9, 2007**
- (30) **Foreign Application Priority Data**
  - Nov. 17, 2006 (JP) ..... 2006-031570
  - Nov. 17, 2006 (JP) ..... 2006-031607
- (51) **LOC (8) Cl.** ..... **24-01**
- (52) **U.S. Cl.** ..... **D24/158**
- (58) **Field of Classification Search** ..... D24/158-161;  
378/4, 19-21, 23, 25, 17, 321, 65, 196, 197;  
324/309, 318, 319; 250/370.08, 370.09  
See application file for complete search history.
- (56) **References Cited**

U.S. PATENT DOCUMENTS

D306,577 S \* 3/1990 Matsutani et al. .... D24/158

(Continued)

FOREIGN PATENT DOCUMENTS

JP 1247196 S 8/2005

*Primary Examiner*—Lou Zarfaz

*Assistant Examiner*—Anhdao Doan

(74) *Attorney, Agent, or Firm*—Birch, Stewart, Kolasch & Birch, LLP

(57) **CLAIM**

The ornamental design for a radiation therapy device, as shown and described.

**DESCRIPTION**

The radiation therapy device according to the design is provided for inserting a treatment table with a patient placed thereon into an opening at the front face of an annular body of the therapy device to provide treatment. In the radiation therapy device, a rotating portion is provided with a radia-

tion irradiator on the inside of the annular body of the therapy device, the rotating portion is rotated around the patient as viewed from the front to determine the position of the irradiator, and an affected area is irradiated with radiation from the irradiator to provide treatment. Further, in the radiation therapy device, the annular body of the therapy device can be rotated with respect to the base as viewed from the top to adjust the orientation of the body of the therapy device.

FIG. 1 is a front view of a radiation therapy device showing our new design;

FIG. 2 is a rear view thereof;

FIG. 3 is a top plan view thereof;

FIG. 4 is a bottom view thereof;

FIG. 5 is a right side view thereof;

FIG. 6 is a left side view thereof;

FIG. 7 is a front perspective view thereof;

FIG. 8 is sectional view thereof taken along line 8—8 of FIG. 1;

FIG. 9 is a front view thereof with the radiation irradiator member in an alternative position;

FIG. 10 is a top plan view thereof with the body portion of the radiation therapy device in an alternative position;

FIG. 11 is a front view of another embodiment of the radiation therapy device;

FIG. 12 is a rear view thereof;

FIG. 13 is a top plan view thereof;

FIG. 14 is a bottom view thereof;

FIG. 15 is a right side view thereof;

FIG. 16 is a left side view thereof;

FIG. 17 is a front perspective view thereof;

FIG. 18 is a sectional view thereof taken along line 18—18 of FIG. 11;

FIG. 19 is a front view thereof with the radiation irradiator member in an alternative position; and,

FIG. 20 is a top plan view thereof with the body portion of the radiation therapy device in an alternative position.

**1 Claim, 20 Drawing Sheets**

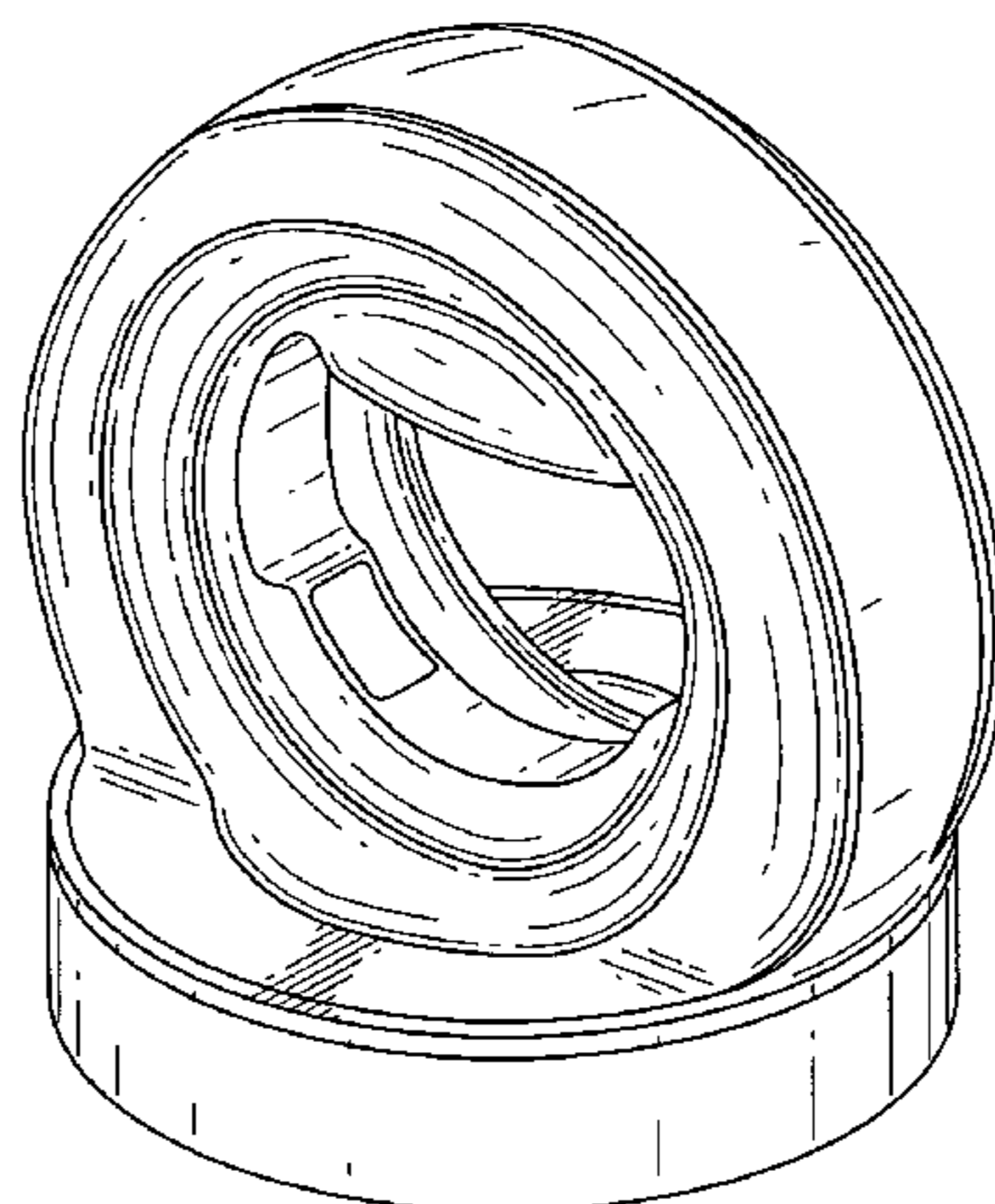

# US D570,484 S

Page 2

---

## U.S. PATENT DOCUMENTS

D345,606 S	*	3/1994	Perusek .....	D24/159	
D386,261 S	*	11/1997	Lee et al. ....	D24/159	
D399,958 S	*	10/1998	Hiramatsu .....	D24/158	* cited by examiner
D414,868 S	*	10/1999	Baars .....	D24/158	
D420,134 S	*	2/2000	Kitayama .....	D24/159	

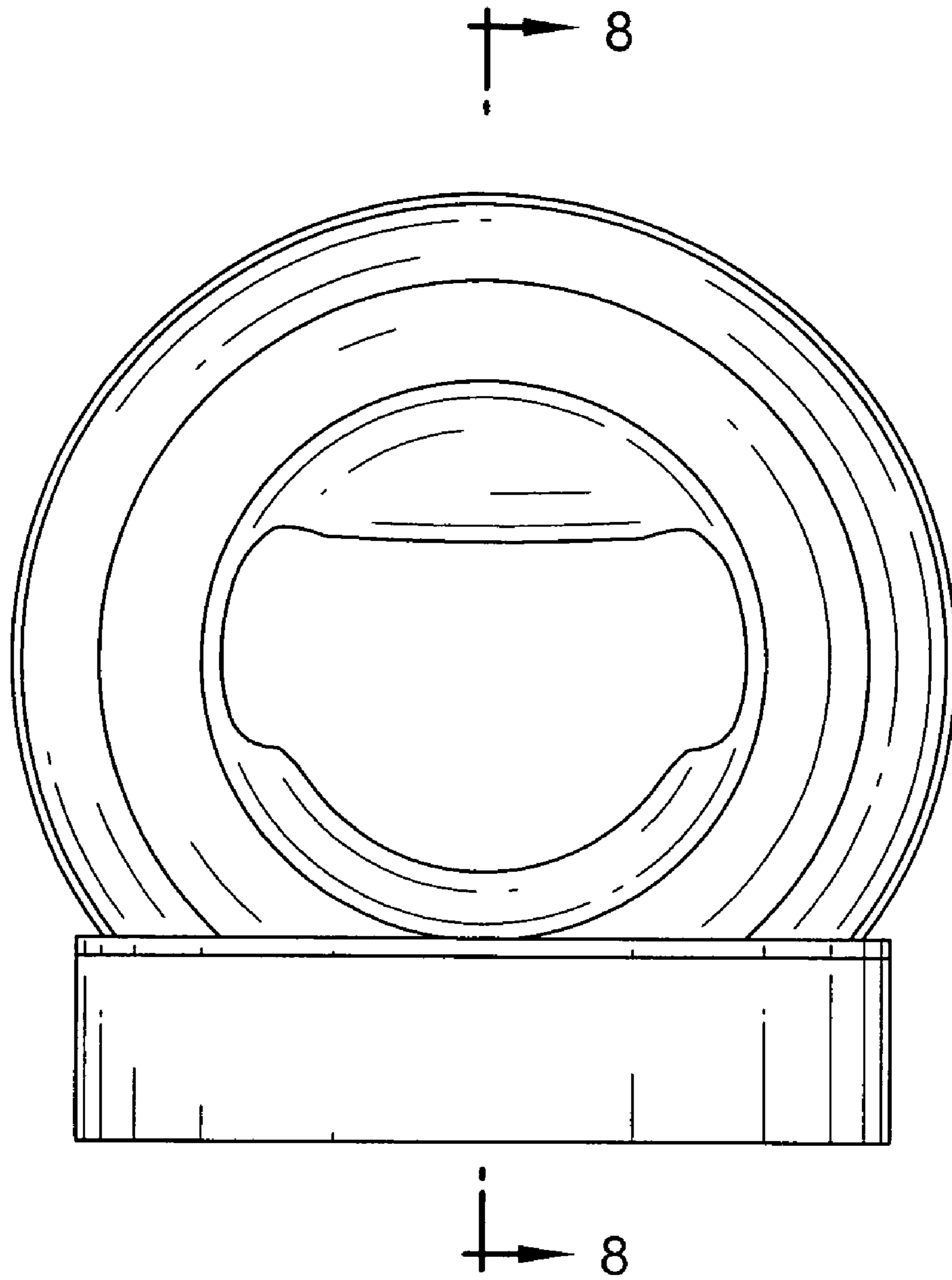

FIG.1

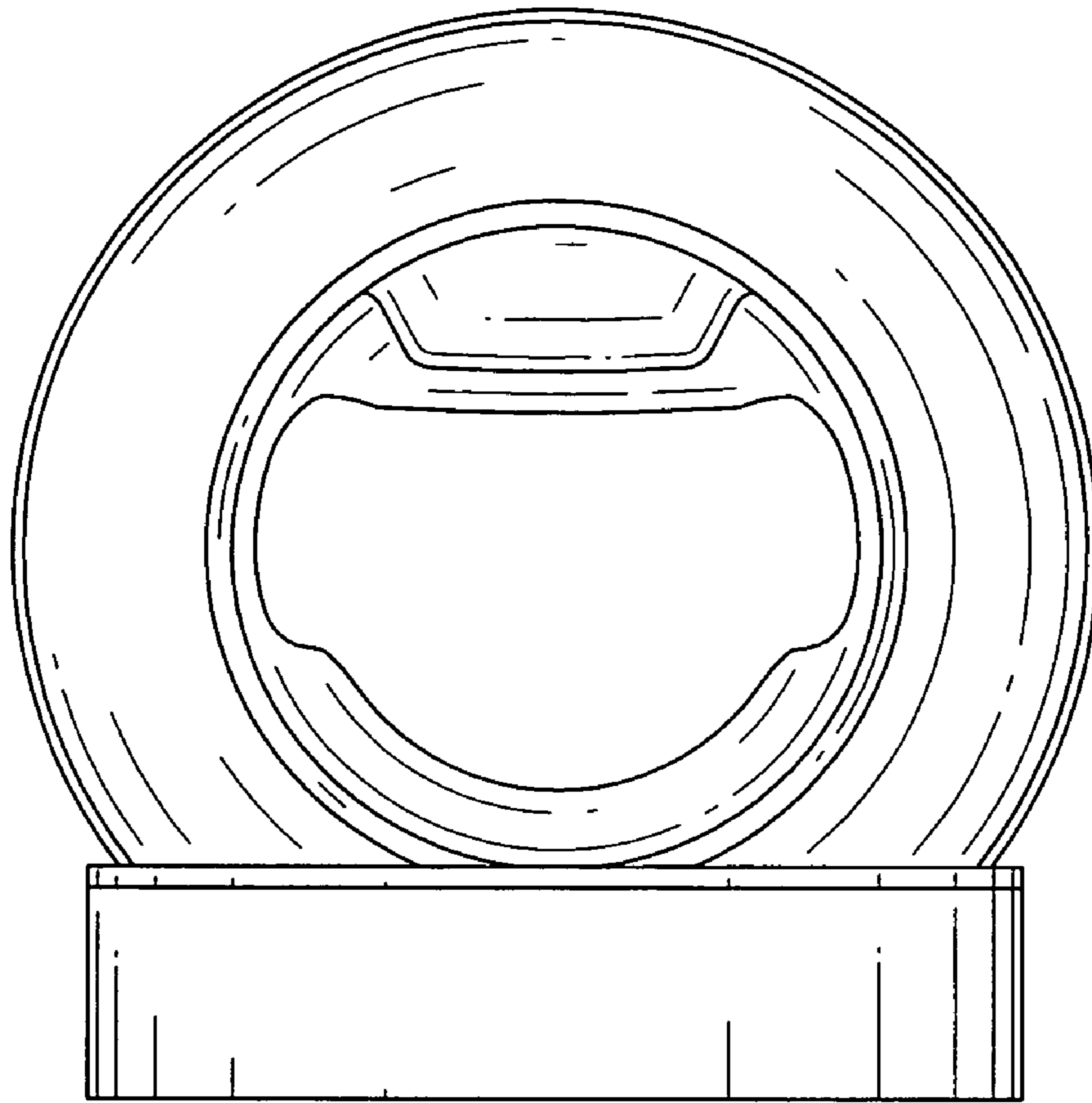

FIG.2

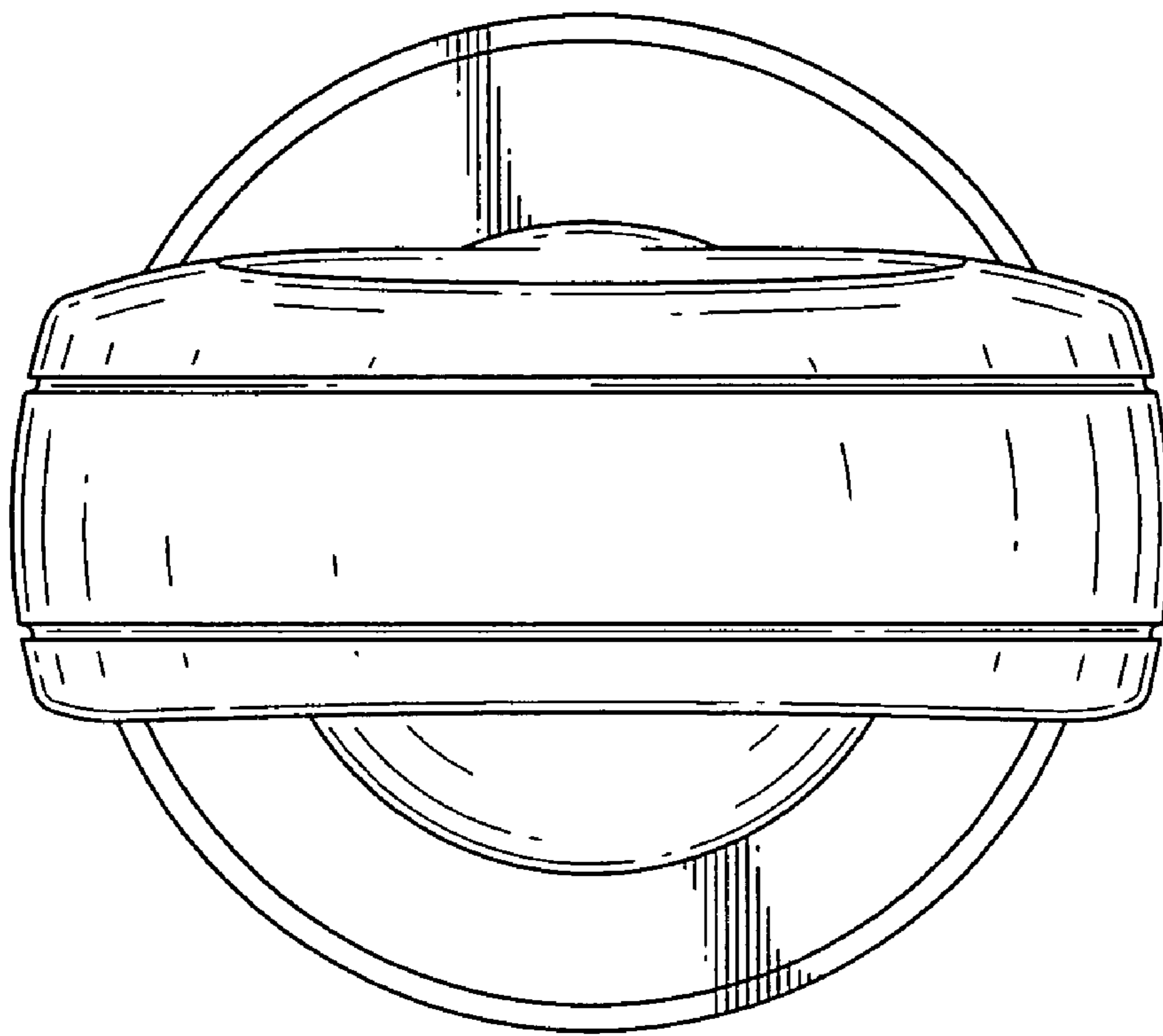

FIG.3

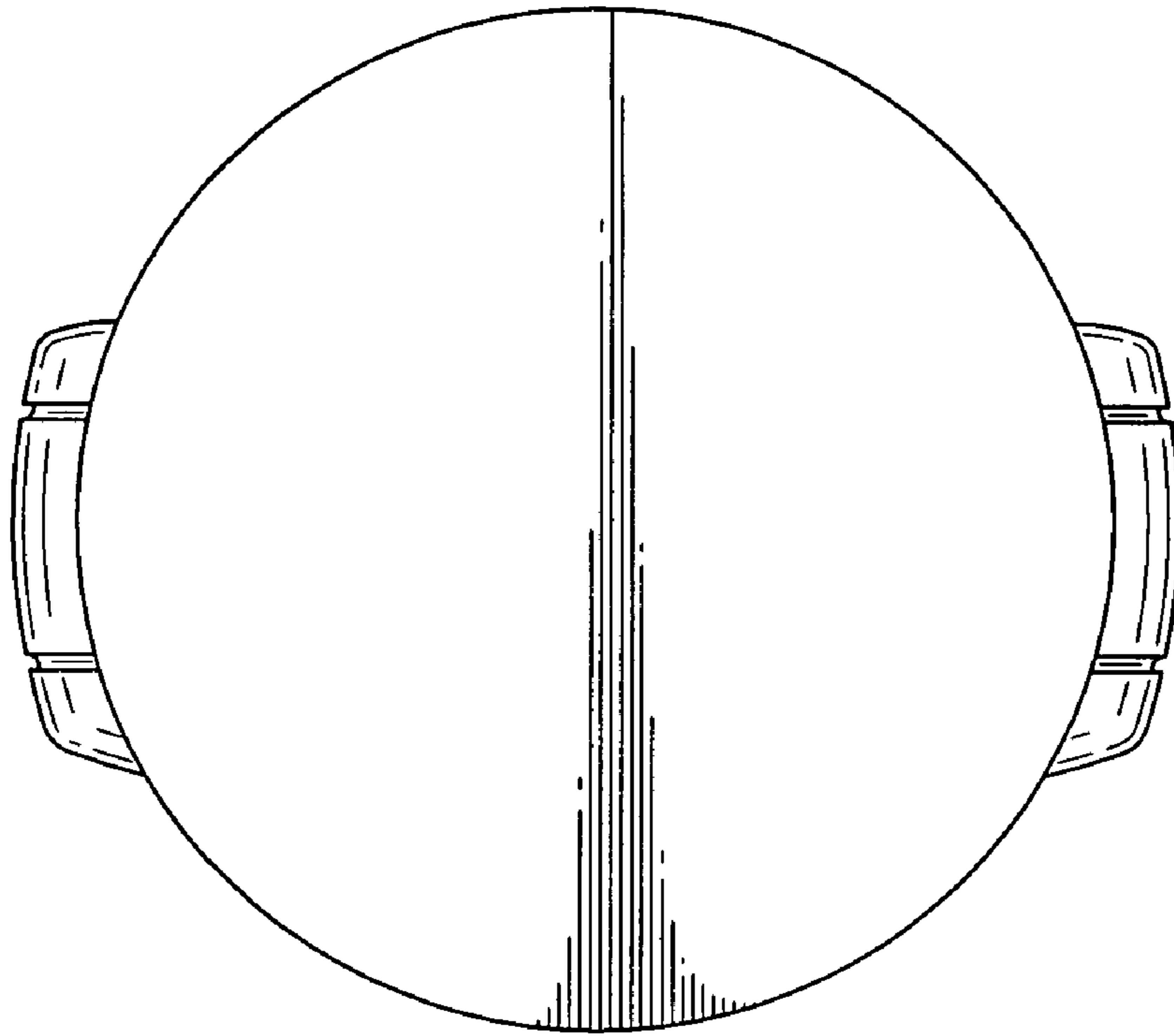

FIG.4

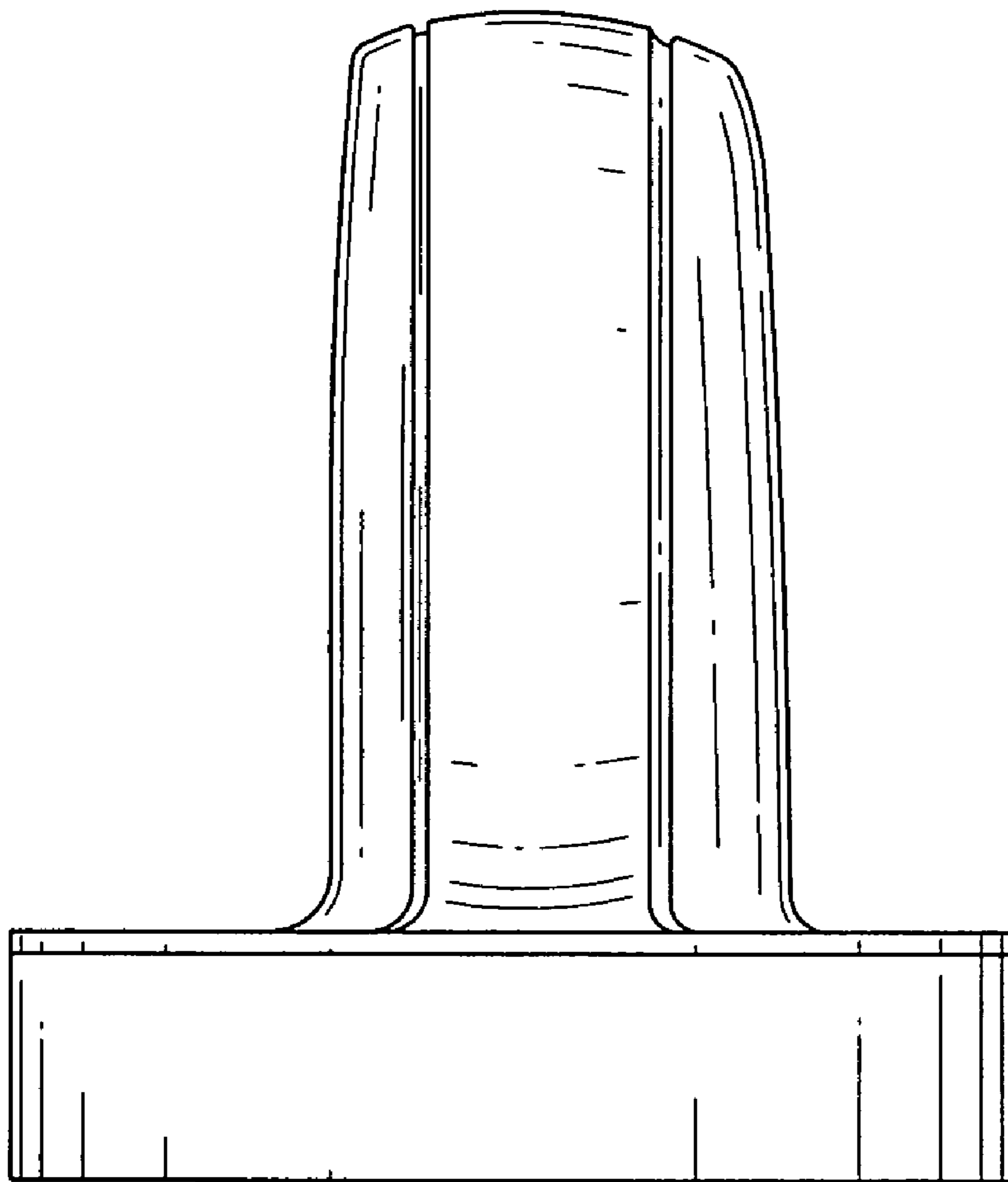

FIG. 5

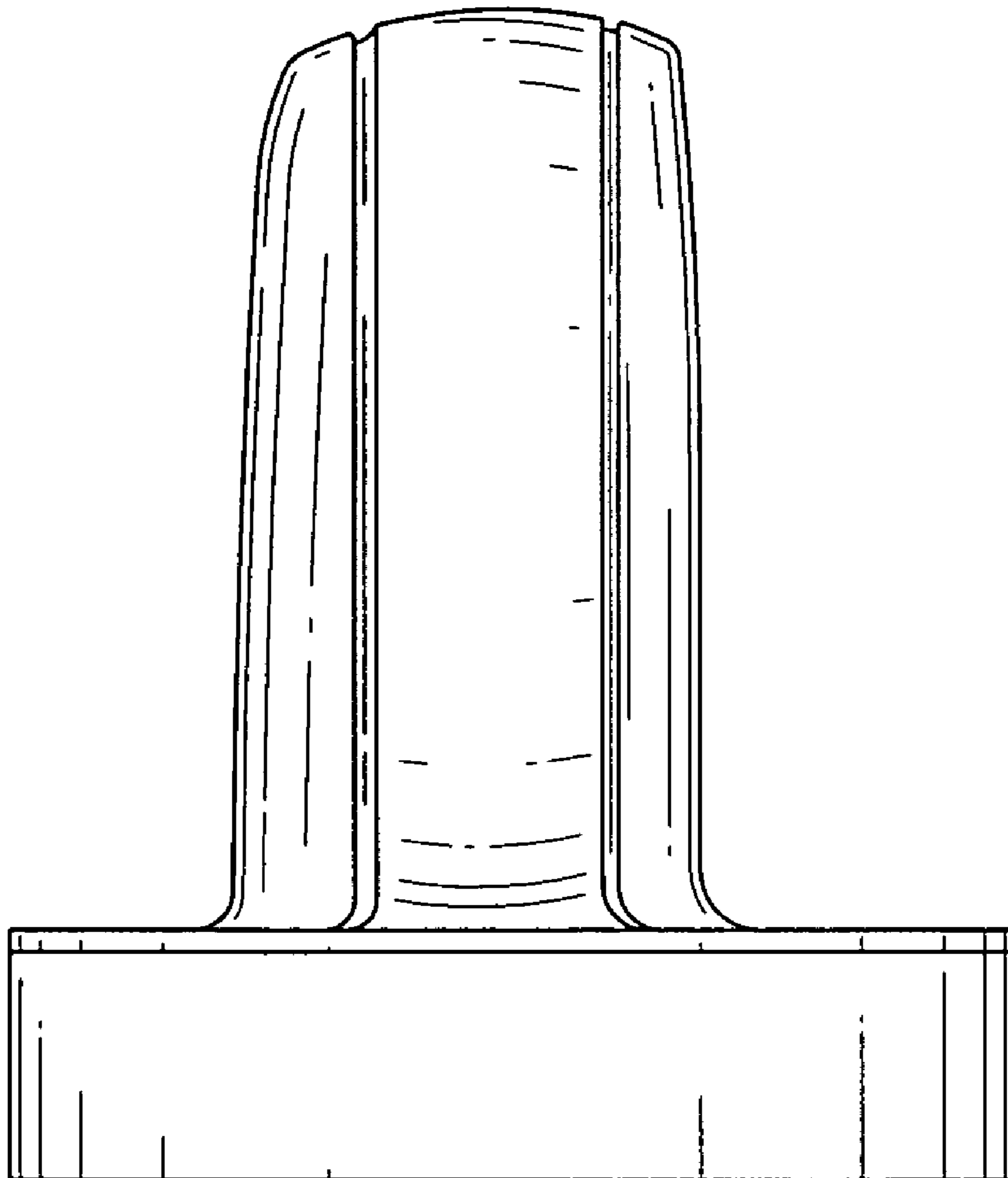

FIG. 6



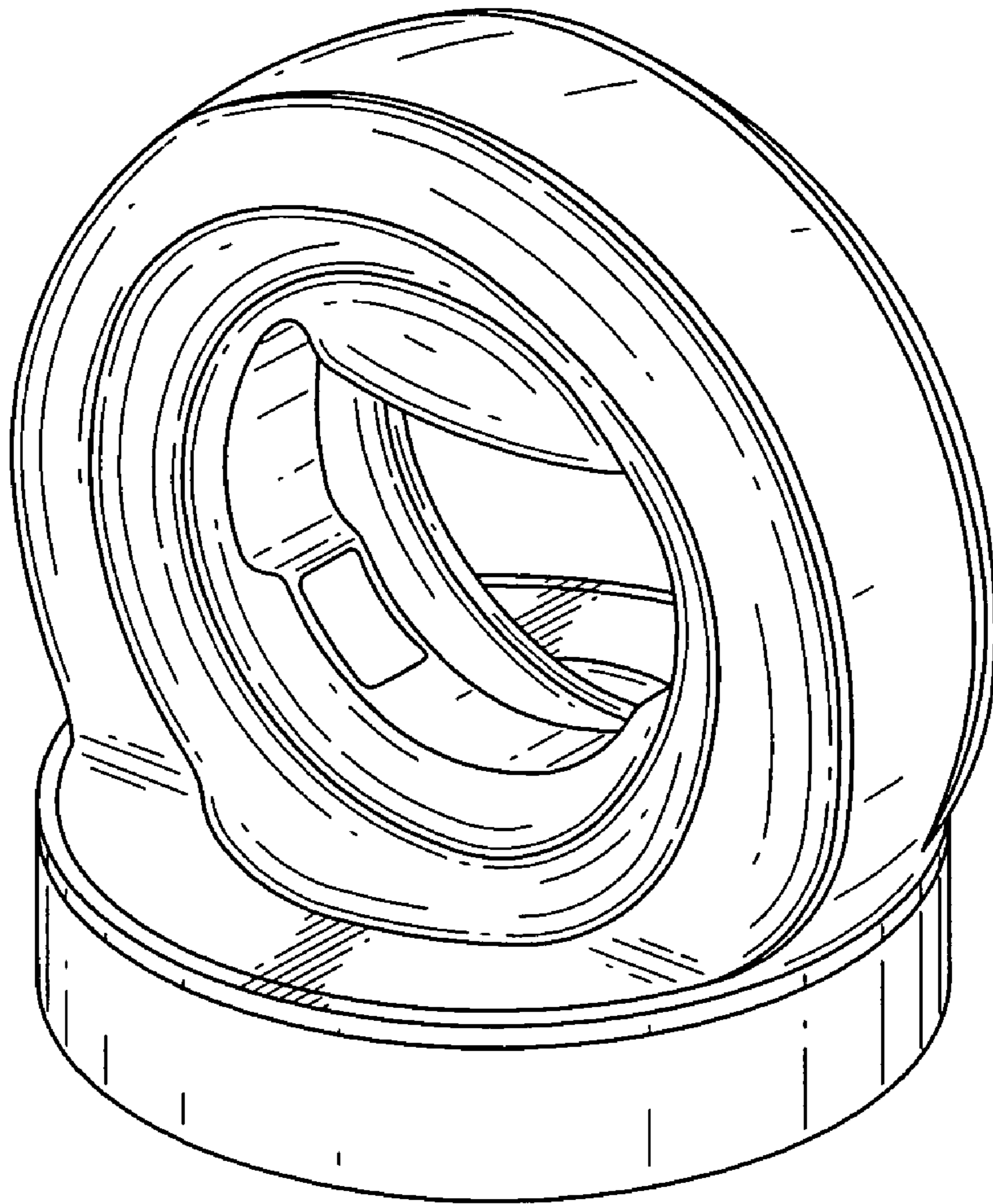

FIG. 7

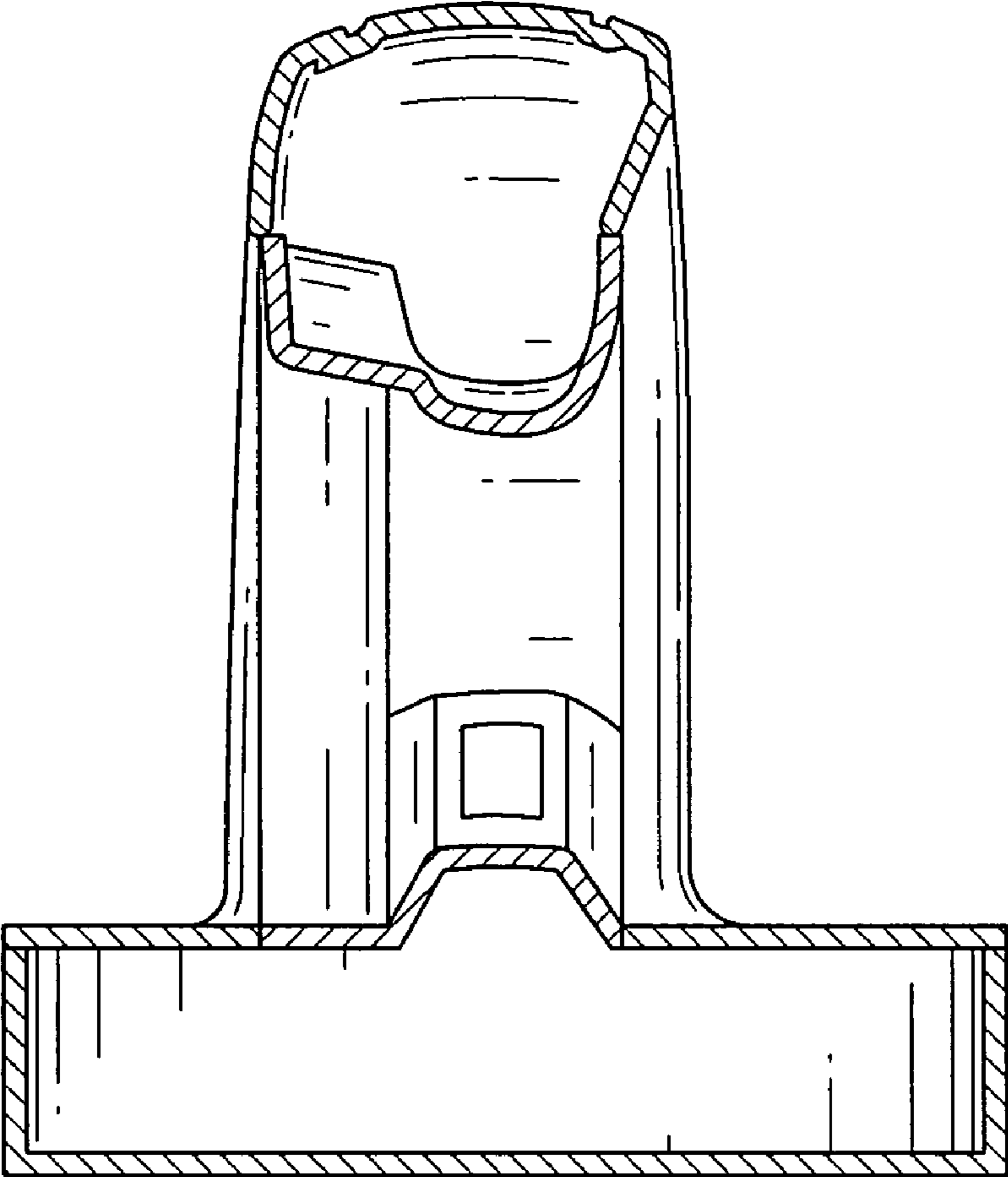

FIG. 8

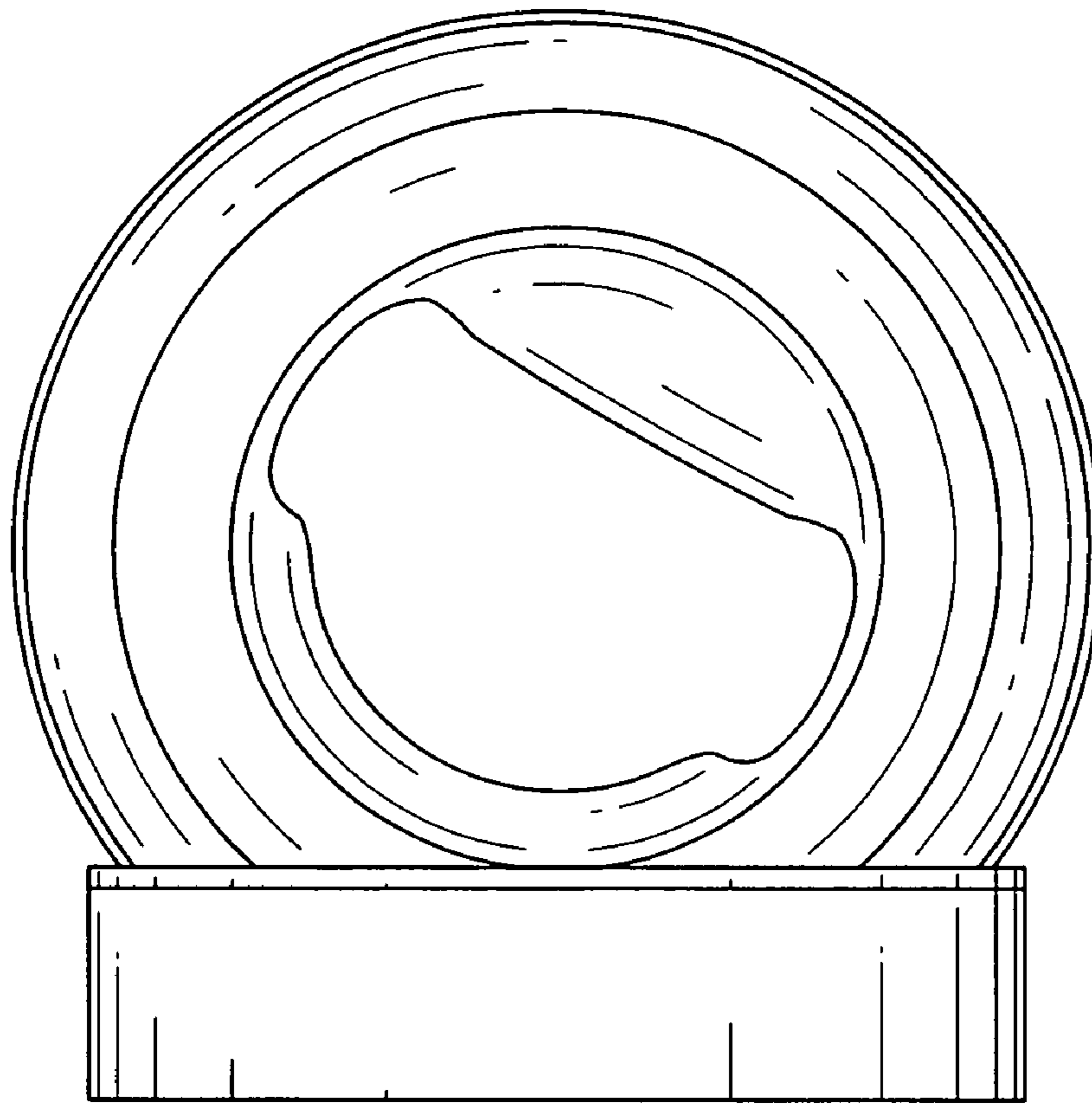

FIG.9

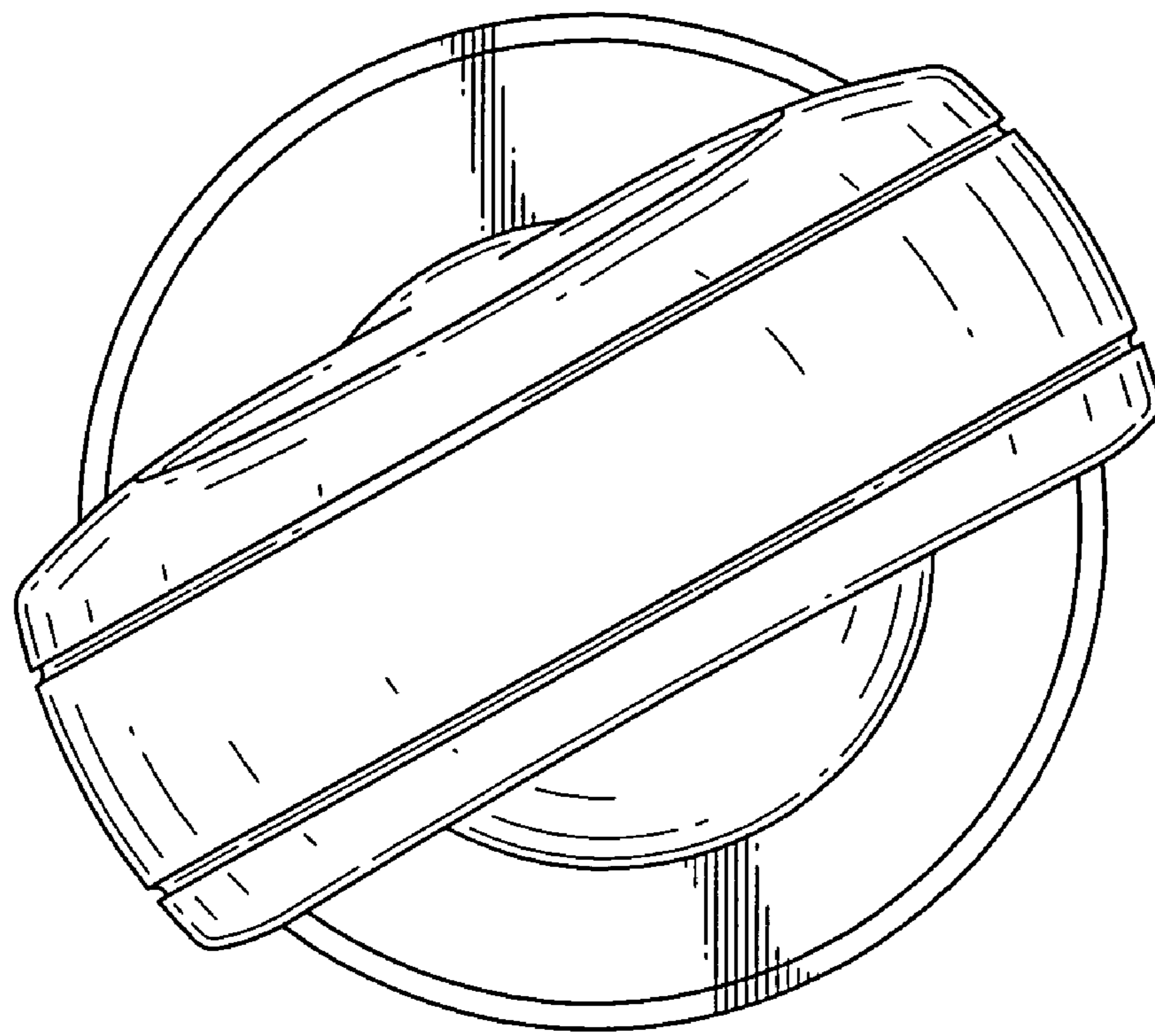

FIG. 10

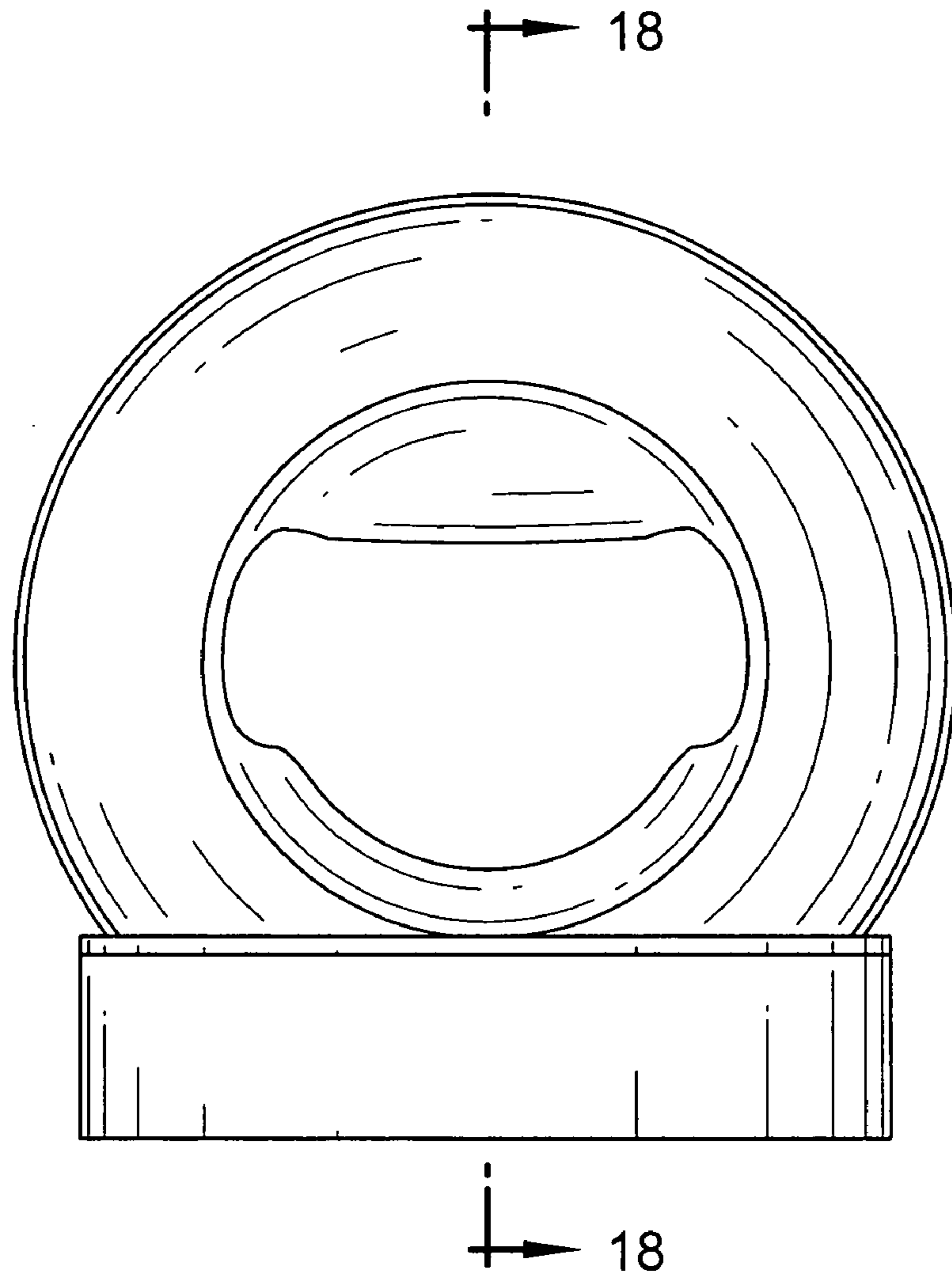

FIG.11

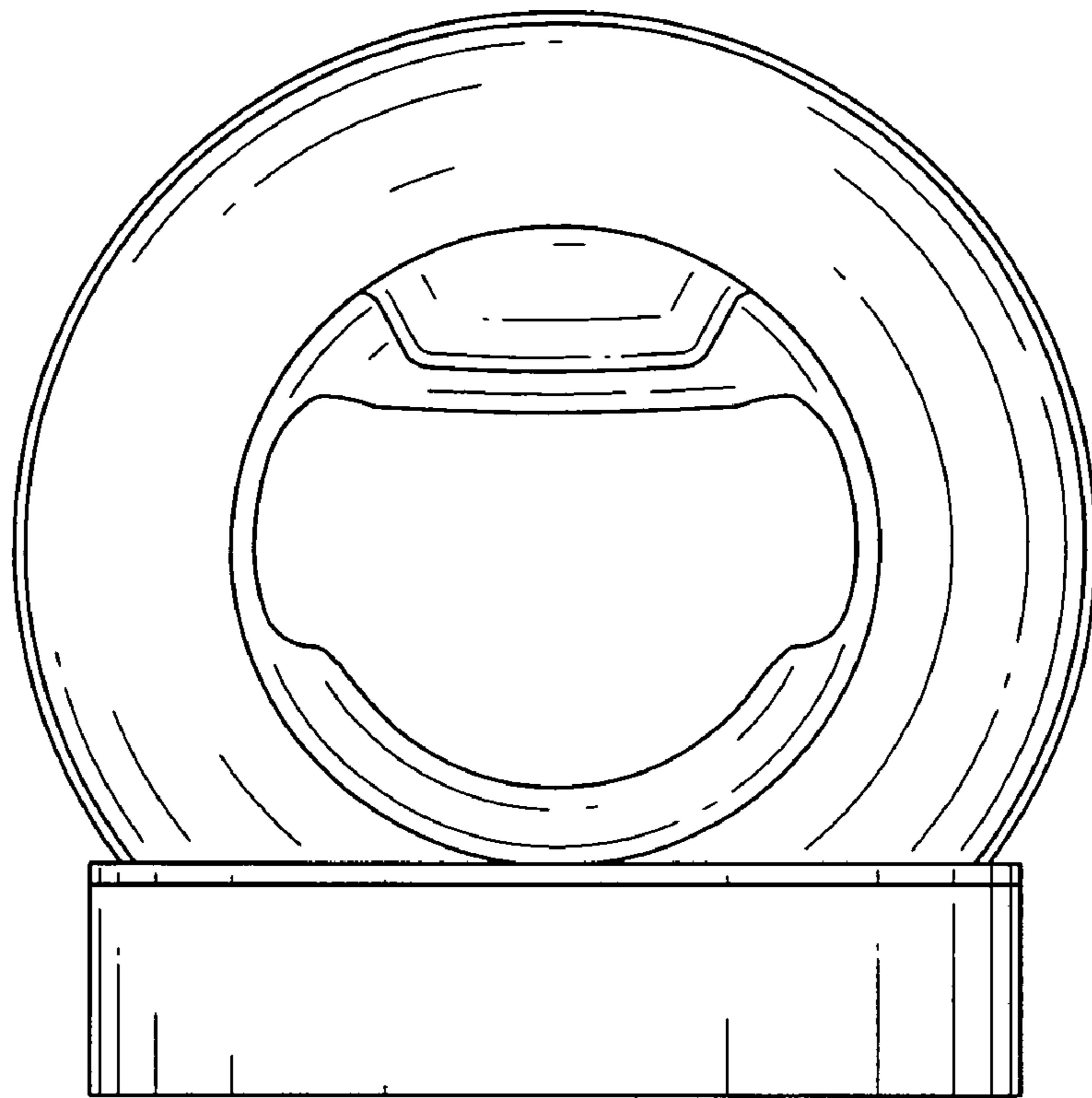

FIG. 12

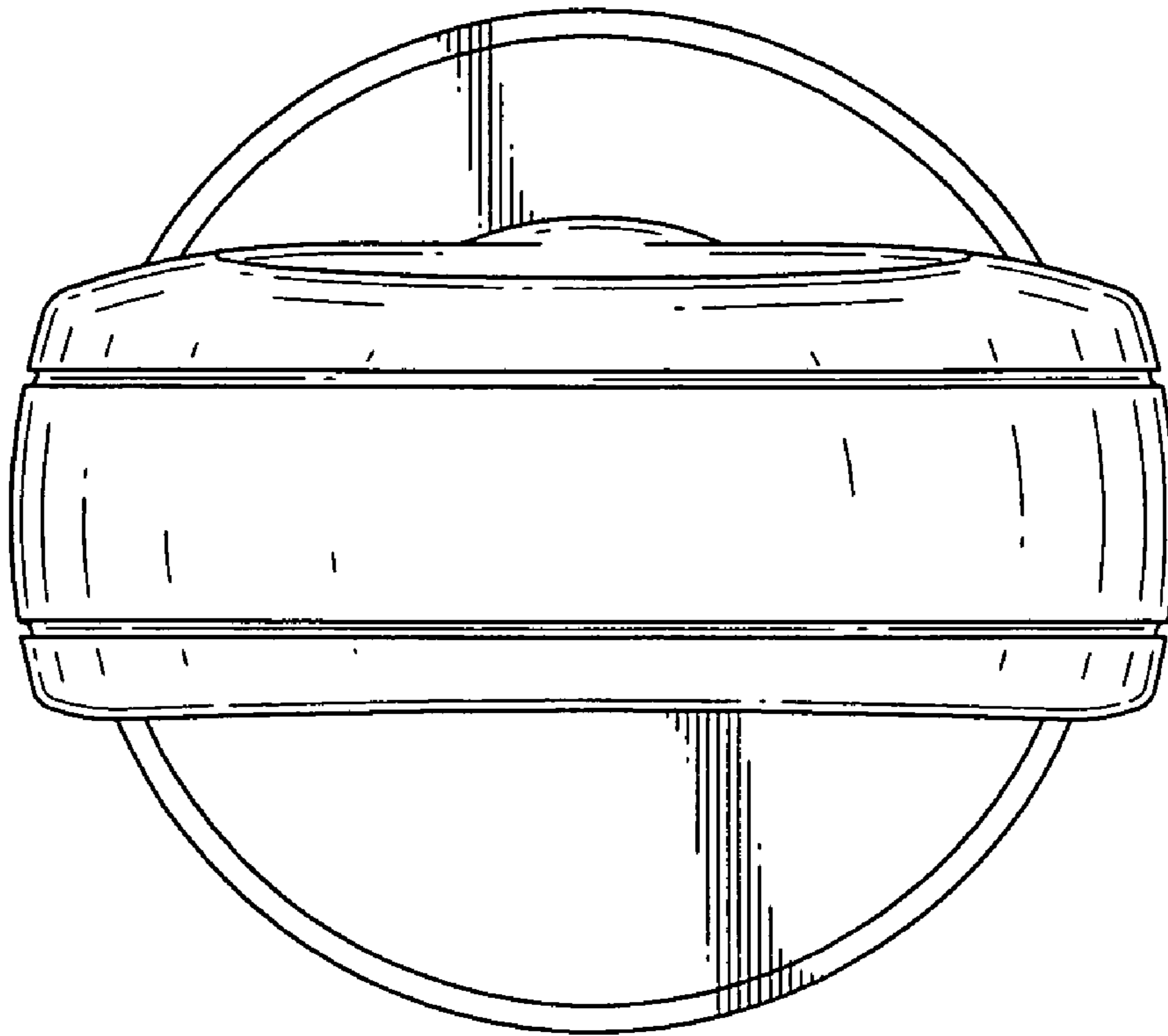

FIG.13

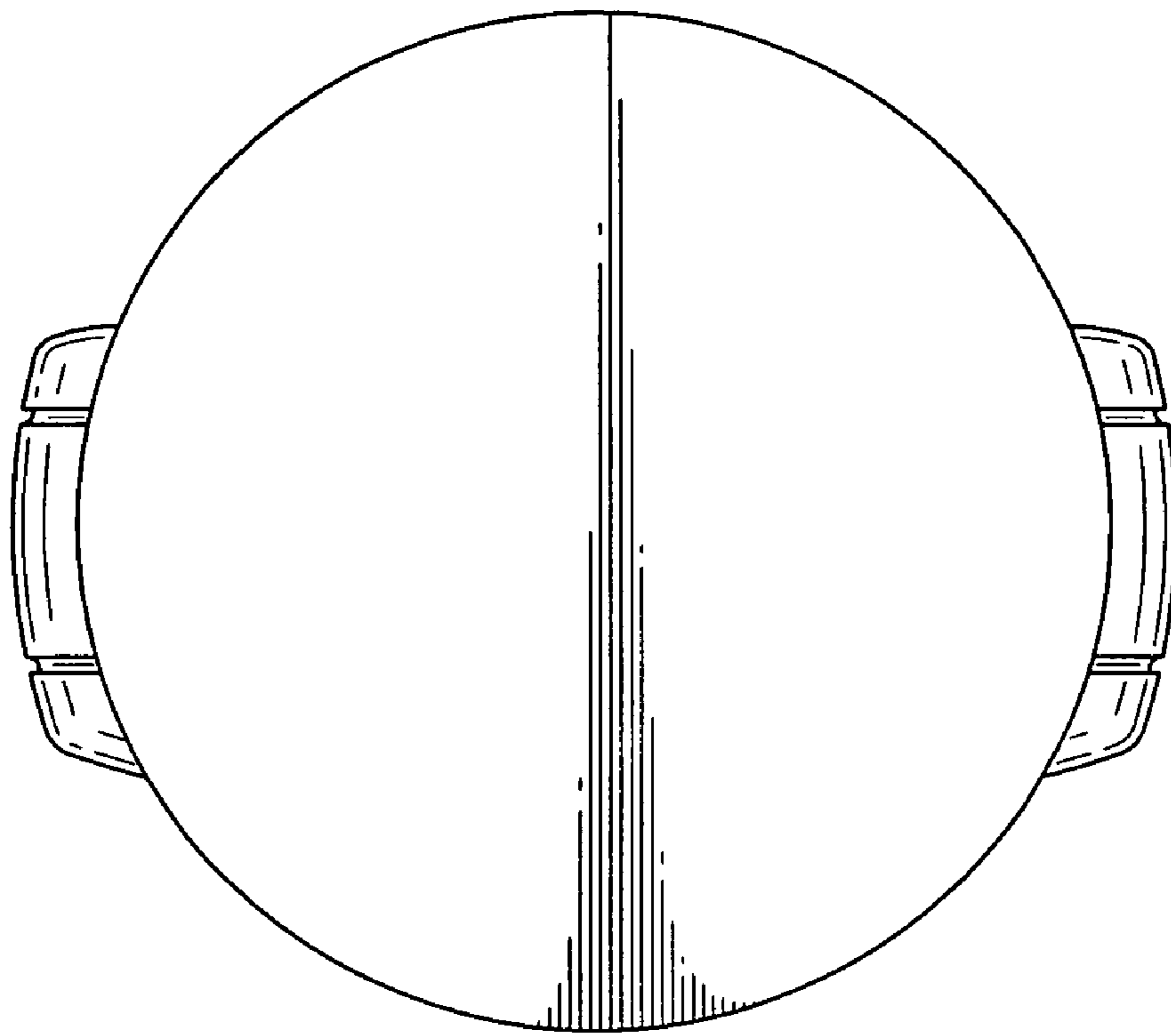

FIG. 14



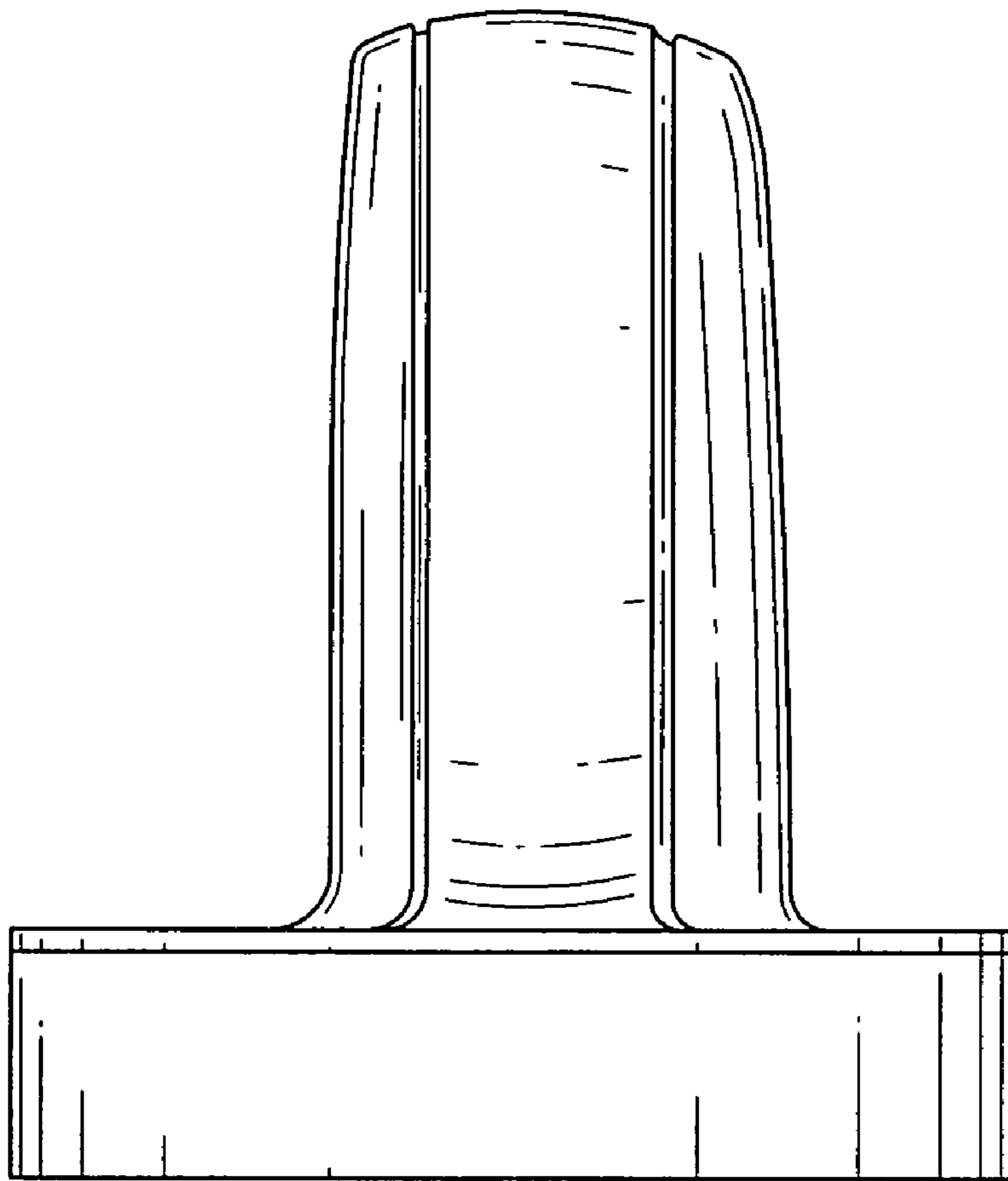

FIG. 15

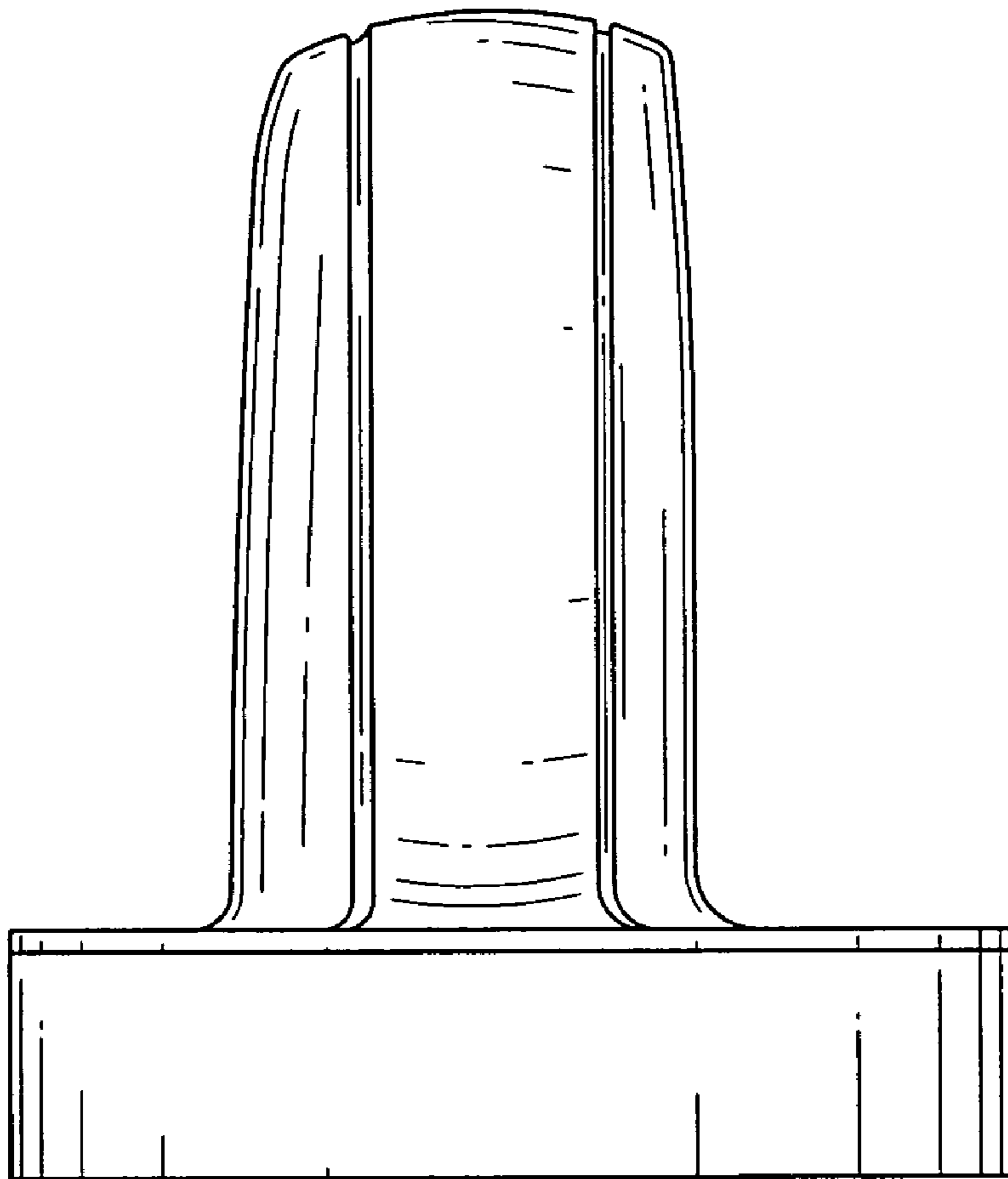

FIG. 16

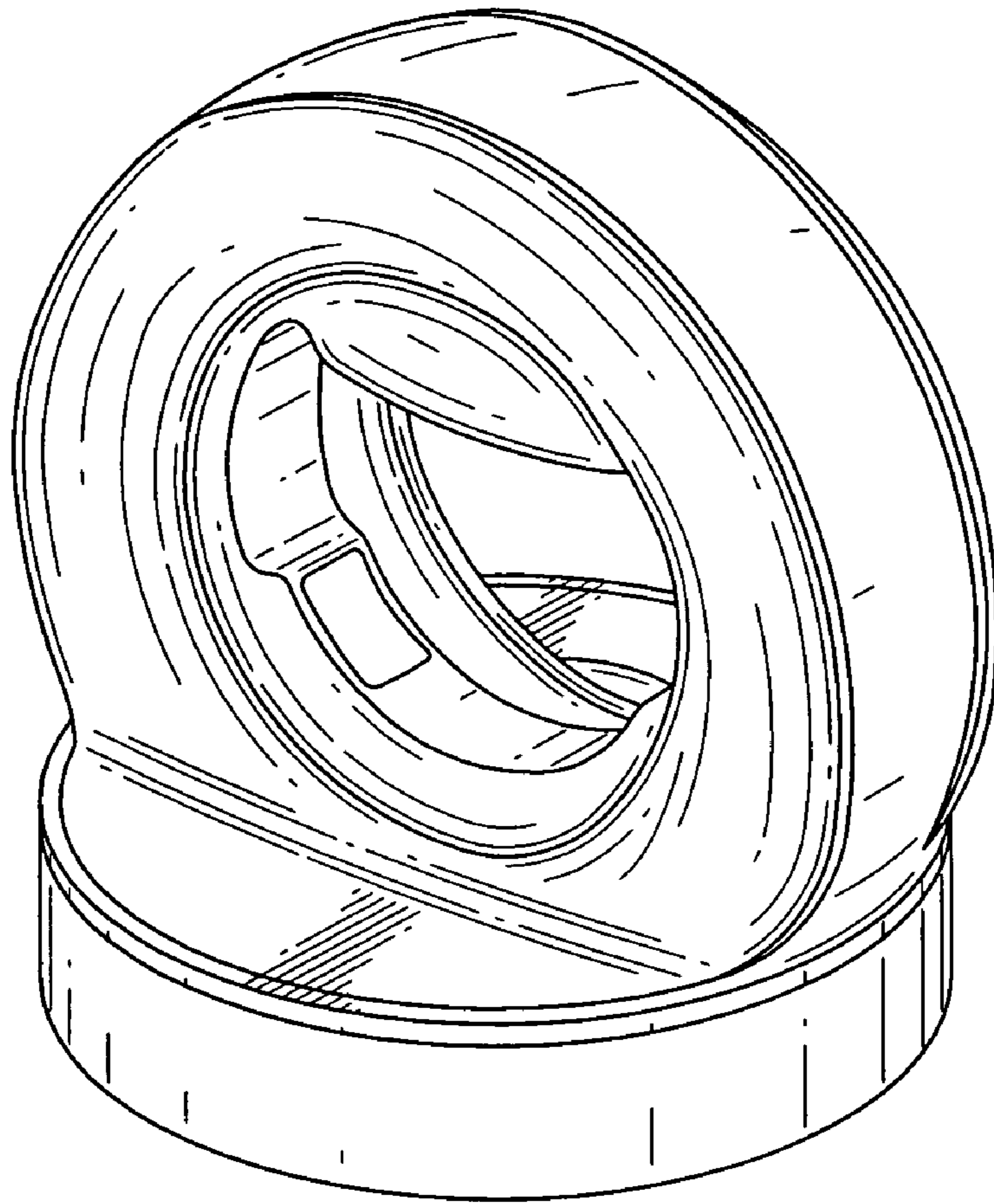

FIG. 17

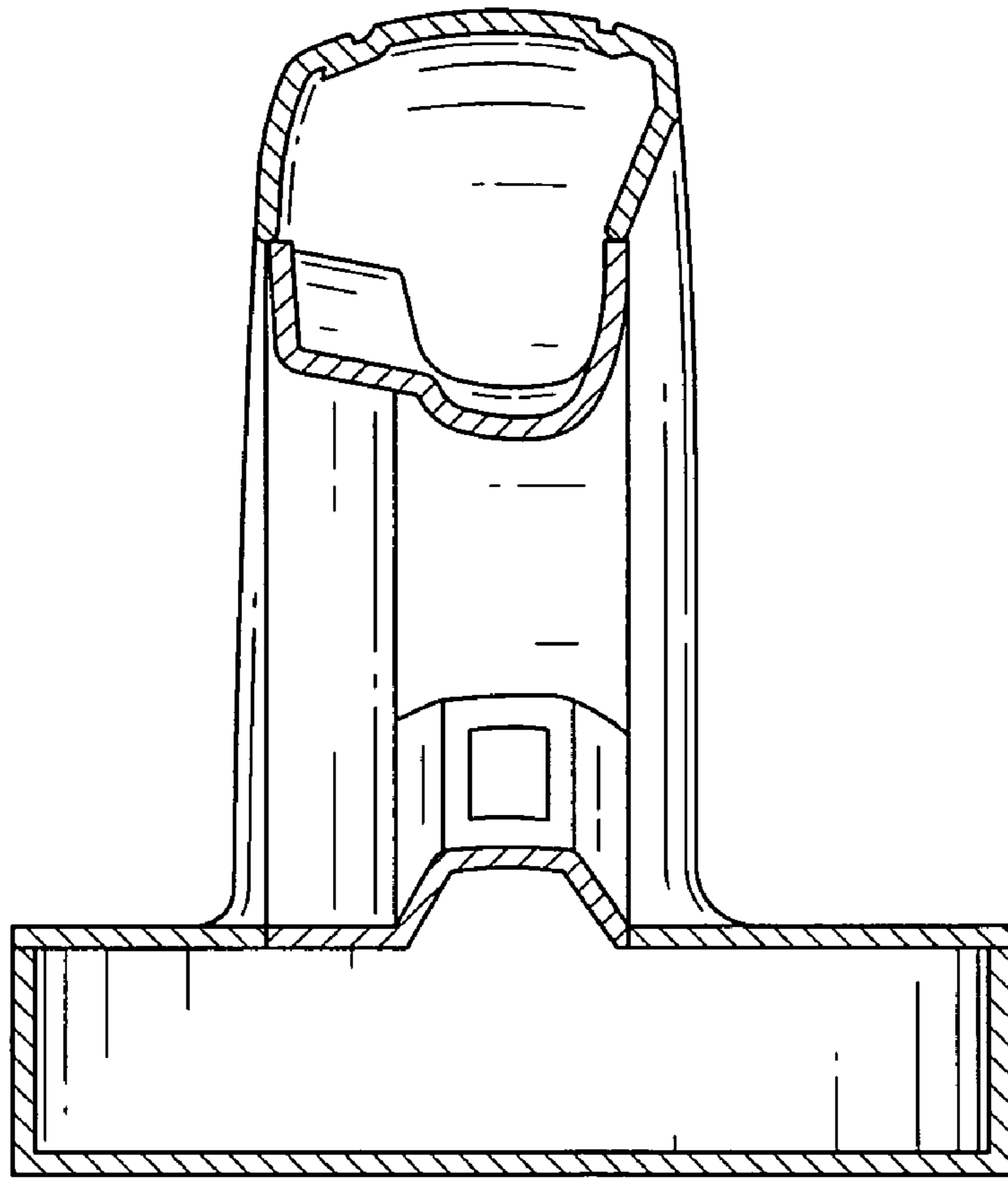

FIG. 18

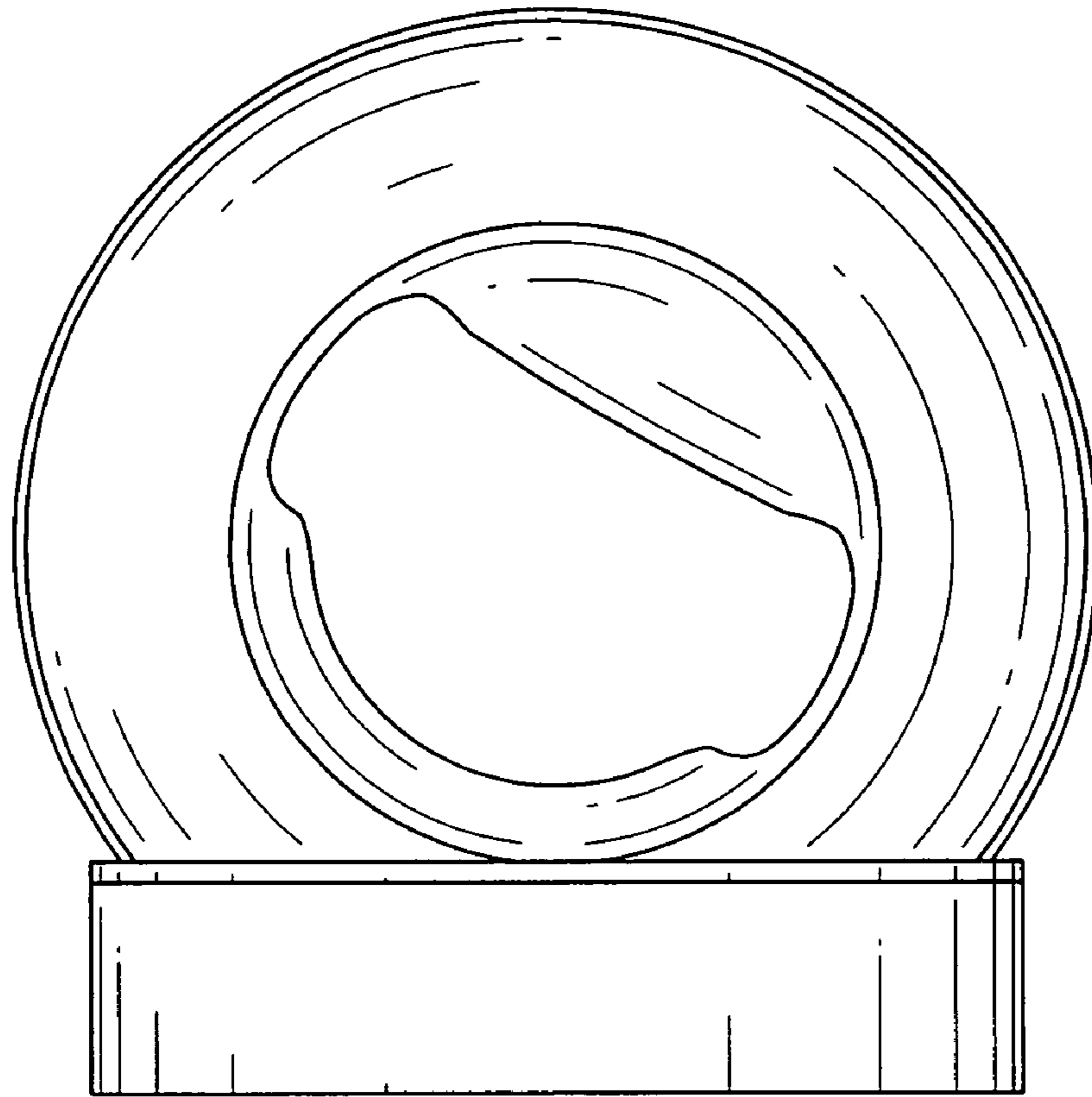

FIG. 19

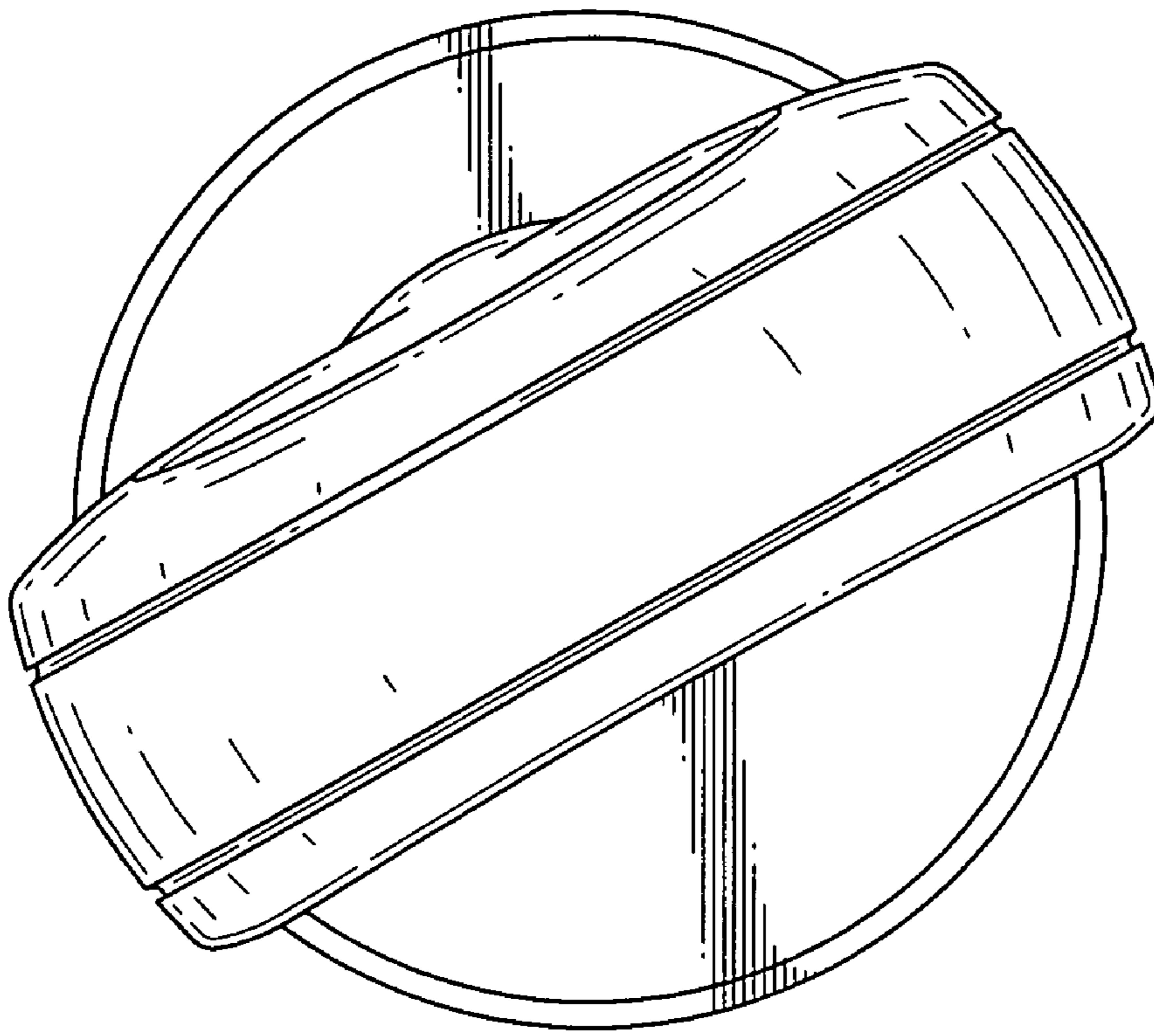

FIG. 20