

US00D570389S

(12) **United States Design Patent**
Nakamura

(10) **Patent No.:** **US D570,389 S**
(45) **Date of Patent:** **** Jun. 3, 2008**

(54) **DIGITAL STILL CAMERA**

(75) Inventor: **Makoto Nakamura**, Kadoma (JP)

(73) Assignee: **Matsushita Electric Industrial Co., Ltd.**, Osaka (JP)

(**) Term: **14 Years**

(21) Appl. No.: **29/288,828**

(22) Filed: **Jun. 22, 2007**

(30) **Foreign Application Priority Data**

Dec. 27, 2006 (JP) 2006-035927

(51) **LOC (8) Cl.** **16-01**

(52) **U.S. Cl.** **D16/202**

(58) **Field of Classification Search** D16/200–206,
D16/208, 209, 218, 219; 348/373–376; 358/909.1;
396/535–541

See application file for complete search history.

(56) **References Cited**

U.S. PATENT DOCUMENTS

- D497,926 S * 11/2004 Yanagisawa et al. D16/202
- D516,599 S * 3/2006 Nakamura D16/218
- D525,638 S 7/2006 Nakamura D16/202
- D528,579 S * 9/2006 Yasutomi D16/202
- D537,093 S * 2/2007 Nakamura D16/202
- D548,252 S * 8/2007 Tajima D16/202
- D553,658 S * 10/2007 Naito et al. D16/202

- D557,307 S * 12/2007 Nakamura D16/202
- D557,722 S * 12/2007 Horiki et al. D16/202
- D558,806 S * 1/2008 Nakamura D16/202
- D558,807 S * 1/2008 Horiki et al. D16/202
- 2005/0057685 A1 * 3/2005 Yamaguchi 348/375

OTHER PUBLICATIONS

Matsushita Electric Industrial Co., Ltd., “Panasonic Models DMC-LZ5”, Apr. 20, 2006, 3 pages.

* cited by examiner

Primary Examiner—Adir Aronovich

(74) *Attorney, Agent, or Firm*—Brinks Hofer Gilson & Lione

(57) **CLAIM**

I claim the ornamental design for a digital still camera, as shown and described.

DESCRIPTION

FIG. 1 is a front perspective view of a digital still camera of the present invention;

FIG. 2 is a front elevational view thereof;

FIG. 3 is a rear elevational view thereof;

FIG. 4 is a right side elevational view thereof;

FIG. 5 is a left side elevational view thereof;

FIG. 6 is a top plan view thereof; and,

FIG. 7 is a bottom plan view thereof.

1 Claim, 4 Drawing Sheets

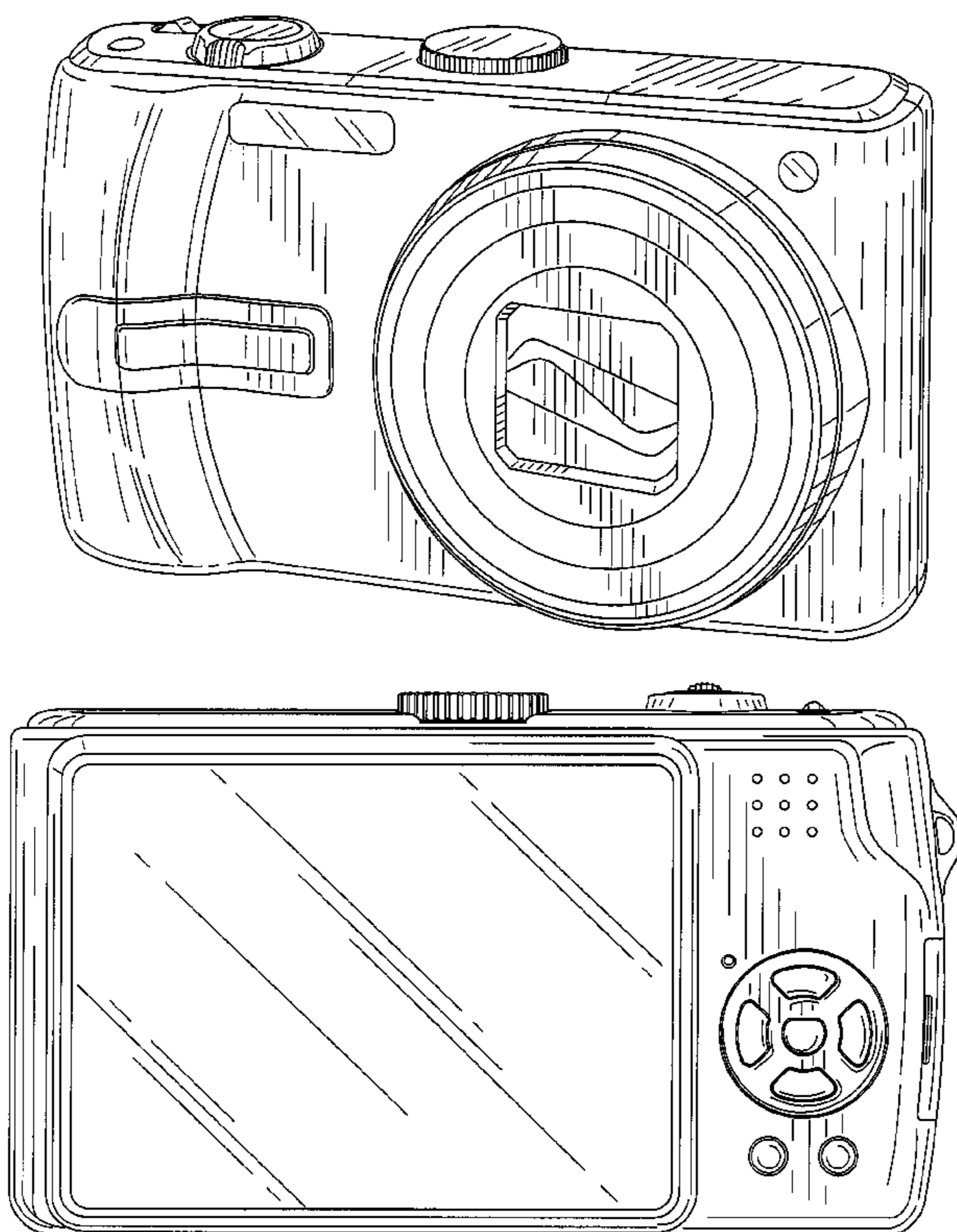

FIG.1

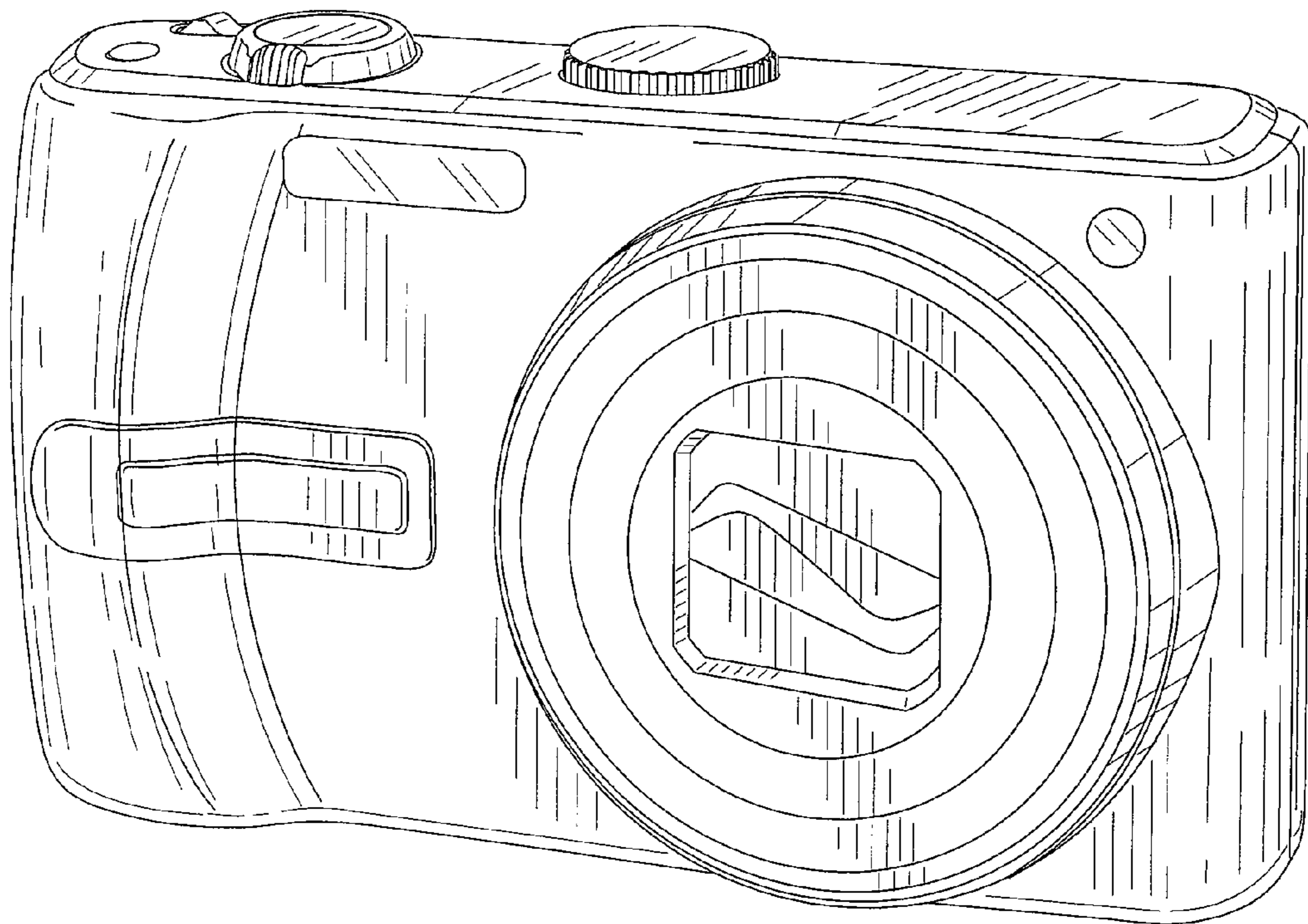

FIG.2

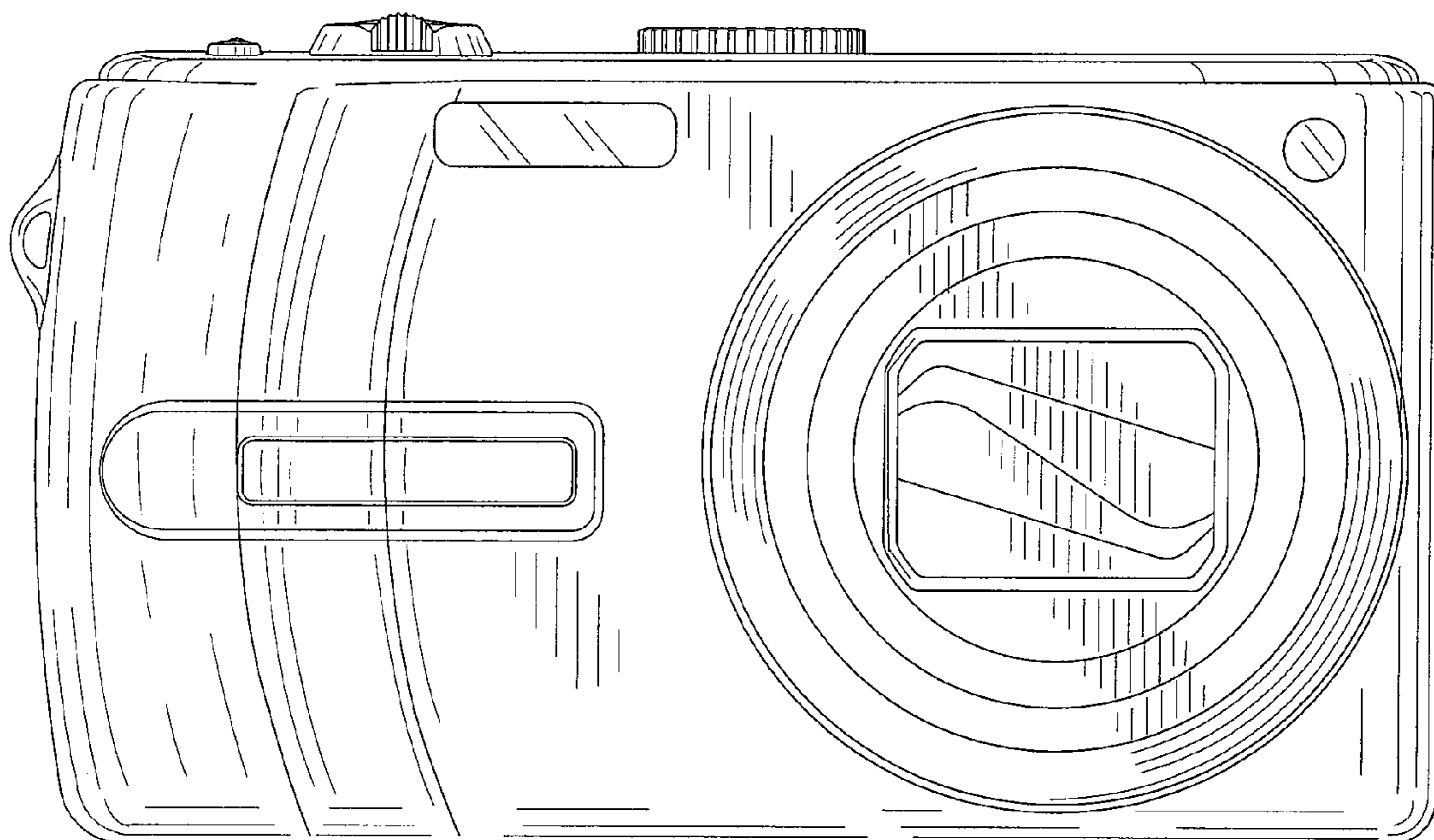

FIG.3

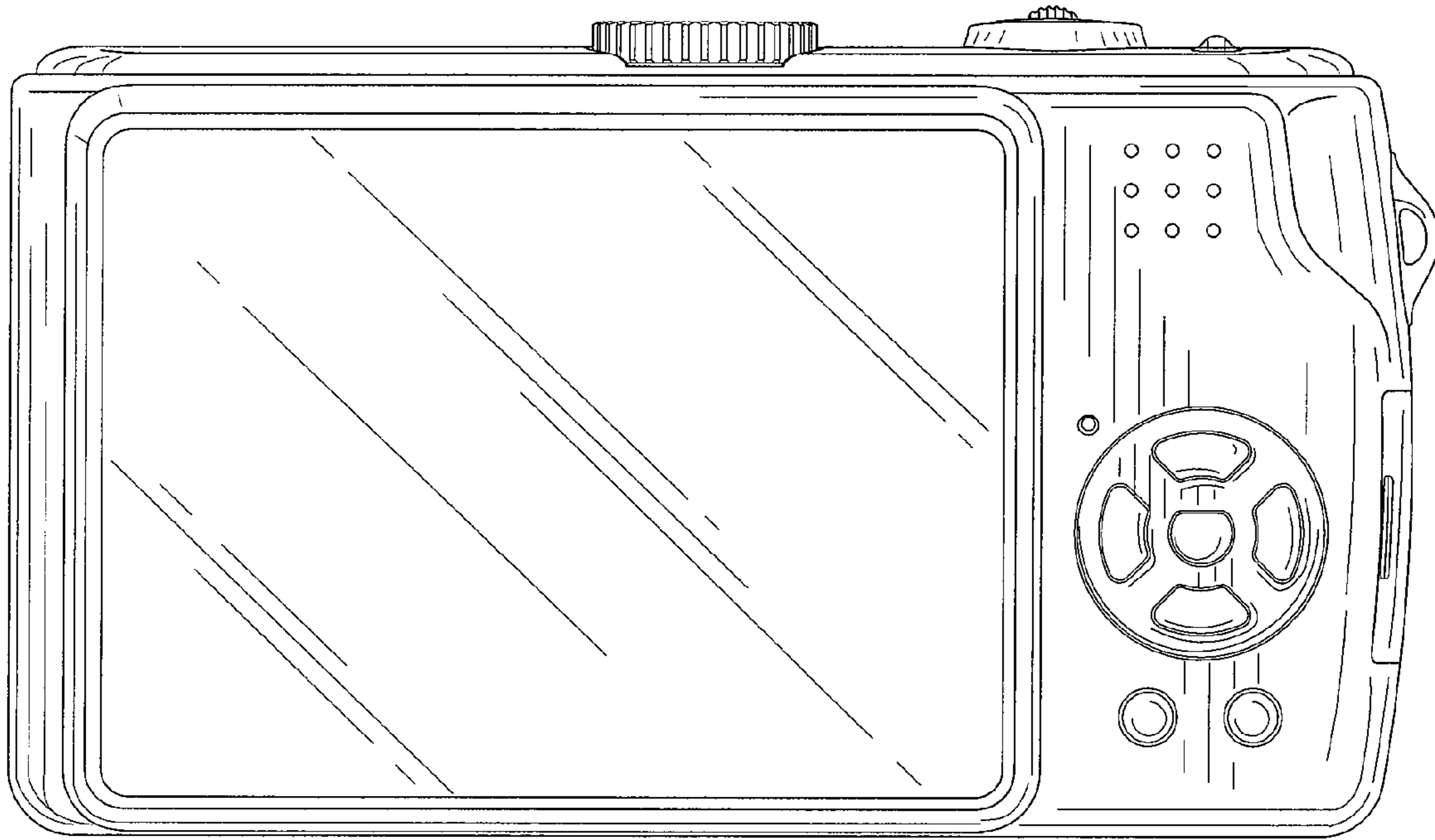

FIG.4

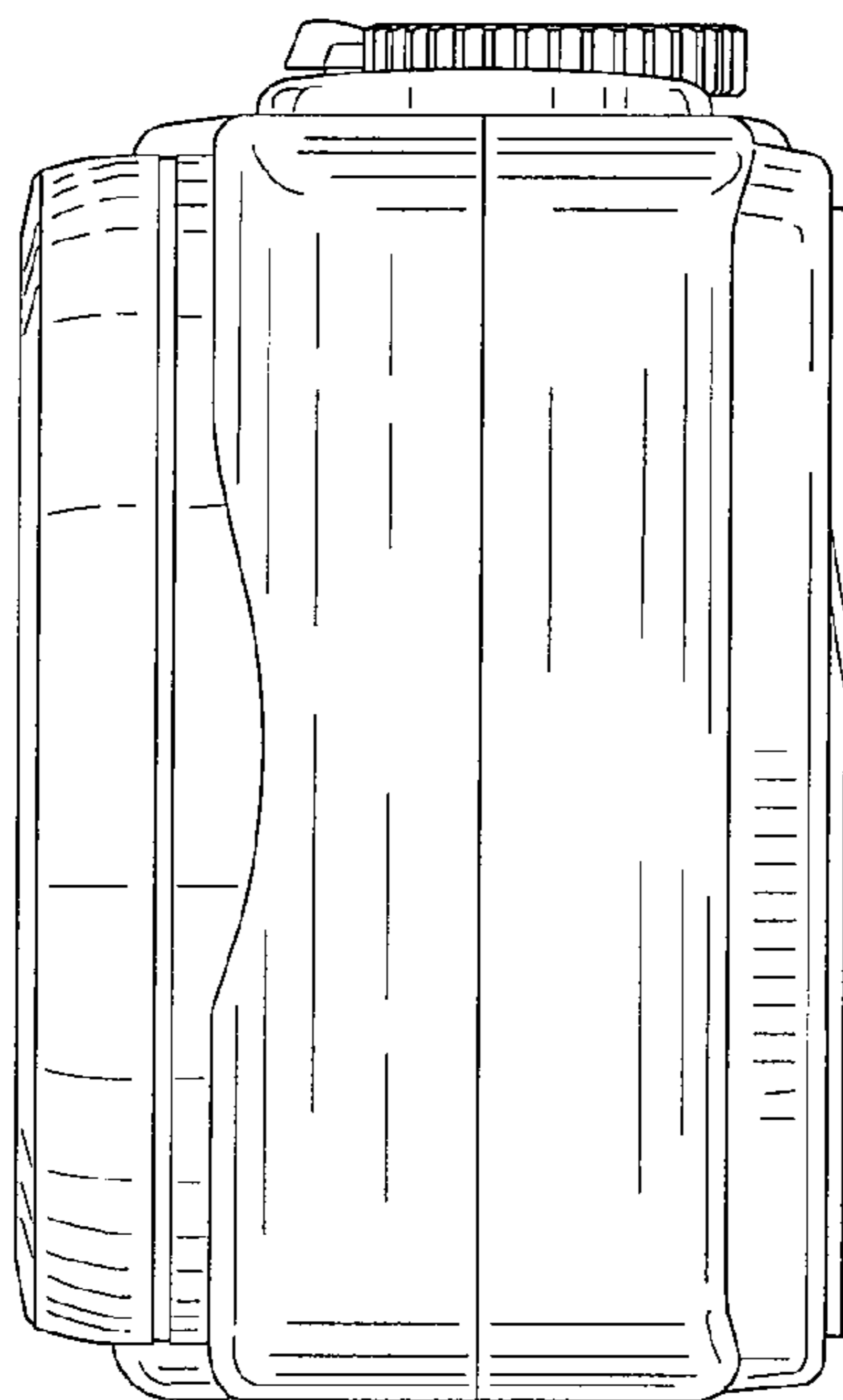

FIG.5

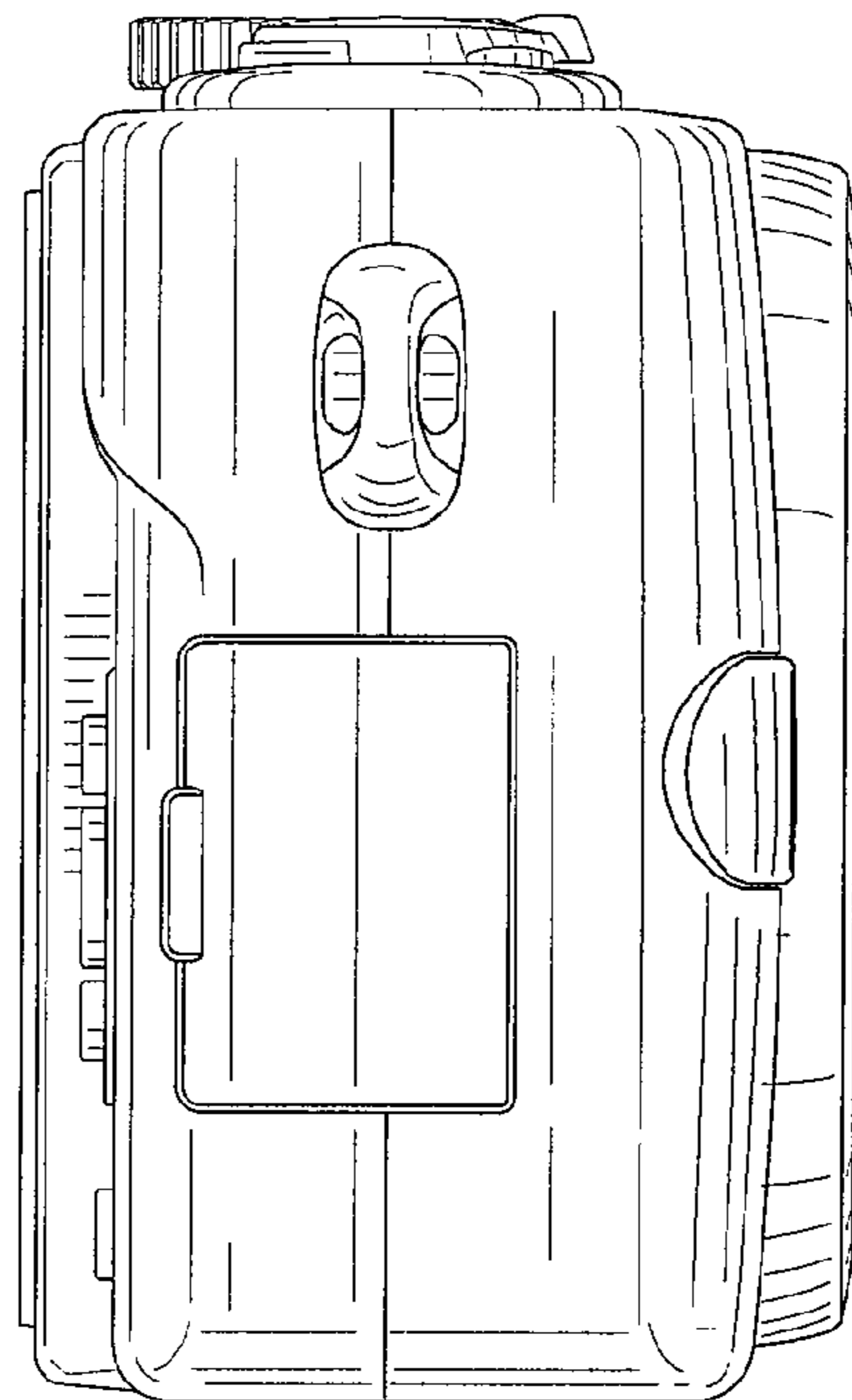

FIG.6

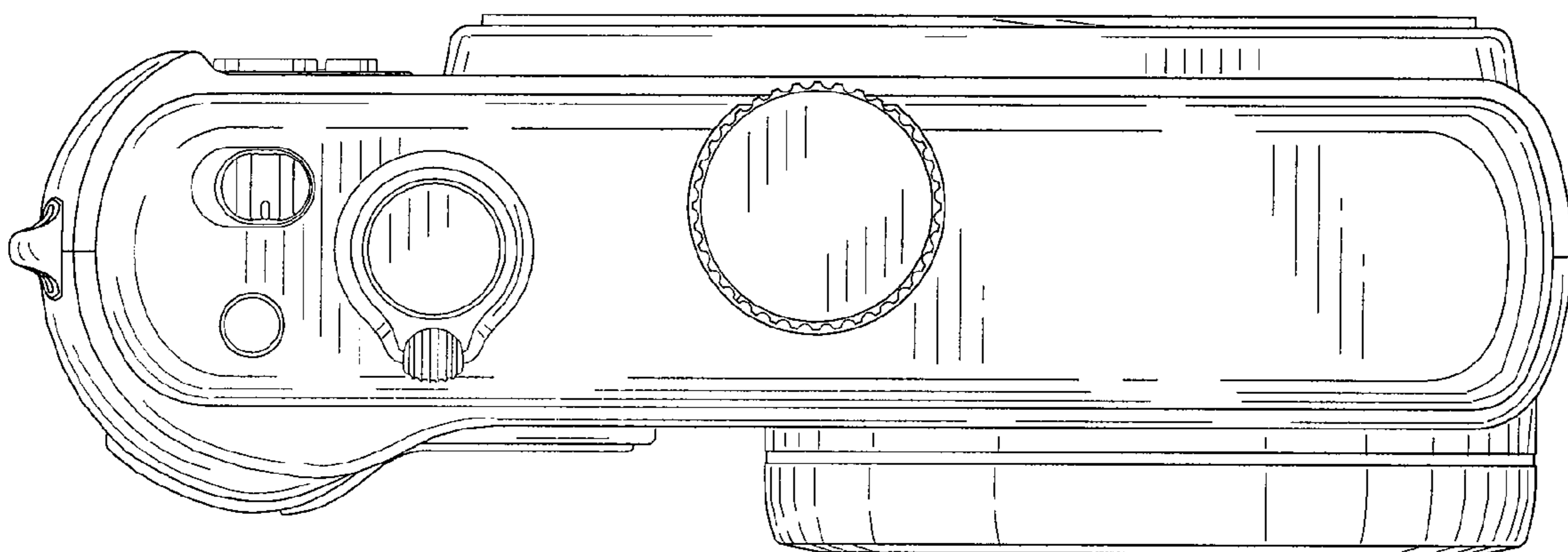

FIG.7

