



US00D570255S

(12) **United States Design Patent**
Kume et al.

(10) **Patent No.:** **US D570,255 S**
(45) **Date of Patent:** **** Jun. 3, 2008**

(54) **SEAT FRAME FOR MOTOR SCOOTER**

(75) Inventors: **Yasuo Kume**, Wako (JP); **Yuji Watanuki**, Wako (JP); **Yasushi Tateishi**, Wako (JP)

(73) Assignee: **Honda Motor Co., Ltd.**, Tokyo (JP)

(**) Term: **14 Years**

(21) Appl. No.: **29/253,262**

(22) Filed: **Feb. 3, 2006**

(30) **Foreign Application Priority Data**

Aug. 3, 2005 (JP) 2005-022517

(51) **LOC (8) Cl.** **12-11**

(52) **U.S. Cl.** **D12/119**

(58) **Field of Classification Search** D12/110,
D12/114, 117, 119, 223; D6/354; 180/219,
180/220, 311; 280/274, 281.1, 304.4, 304.5,
280/288.1-288.4, 288; 297/195.1, 195.12,
297/215.1, 215.11, 183.7, 183.9

See application file for complete search history.

(56) **References Cited**

U.S. PATENT DOCUMENTS

D521,418 S * 5/2006 Lee D12/117

* cited by examiner

Primary Examiner—Alan P. Douglas

Assistant Examiner—Linda Brooks

(74) *Attorney, Agent, or Firm*—Birch, Stewart, Kolasch & Birch, LLP

(57) **CLAIM**

The ornamental design for a seat frame for motor scooter, as shown and described.

DESCRIPTION

FIG. 1 is a perspective view of the front and left side of a seat frame for motor scooter showing our new design;

FIG. 2 is a perspective view of the rear and left side thereof;

FIG. 3 is a perspective view of the front and right side thereof;

FIG. 4 is a perspective view of the rear and right side thereof;

FIG. 5 is a front elevational view thereof;

FIG. 6 is a rear elevational view thereof;

FIG. 7 is a left side elevational view thereof;

FIG. 8 is a right side elevational view thereof;

FIG. 9 is a top plan view thereof; and,

FIG. 10 is a bottom plan view thereof.

1 Claim, 10 Drawing Sheets

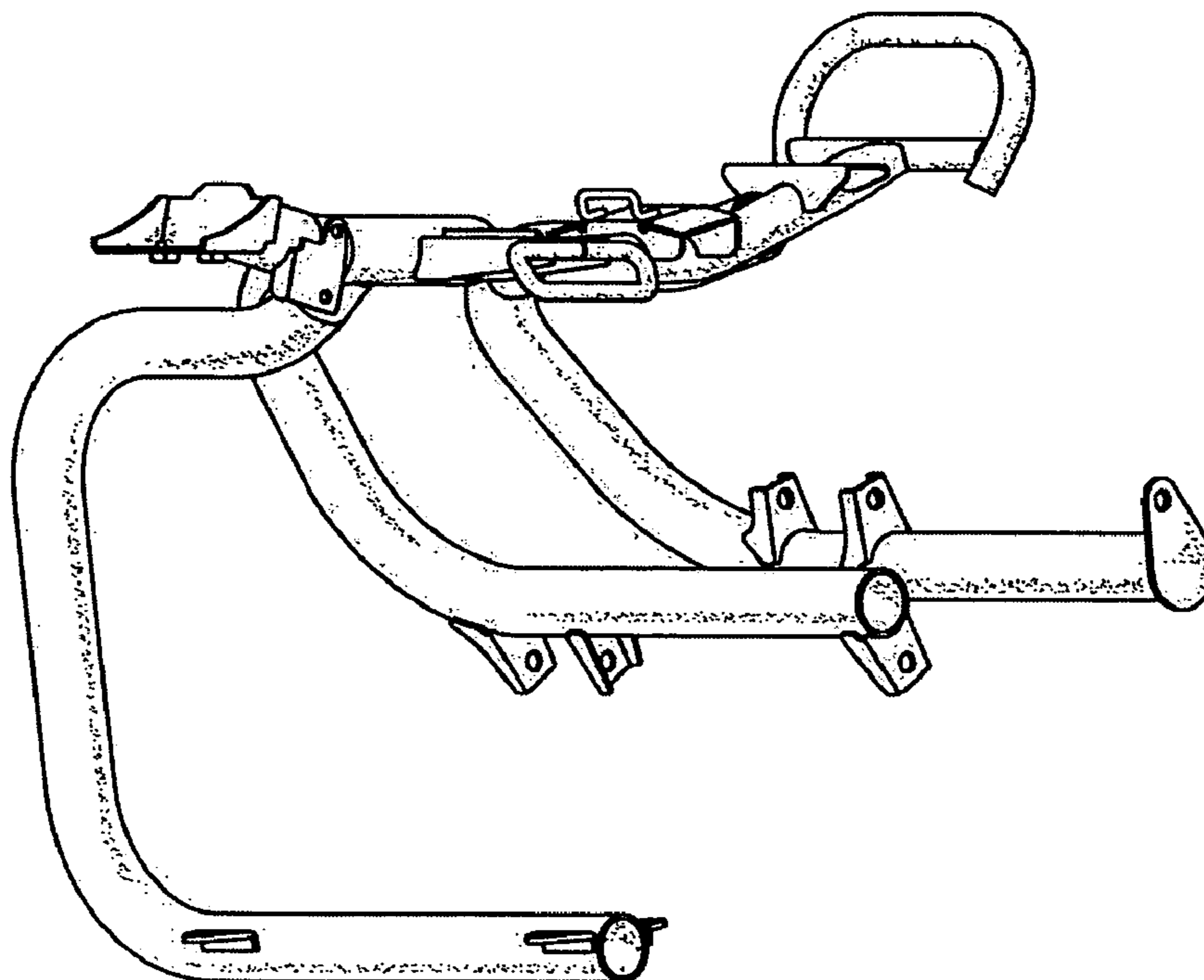

FIG. 1

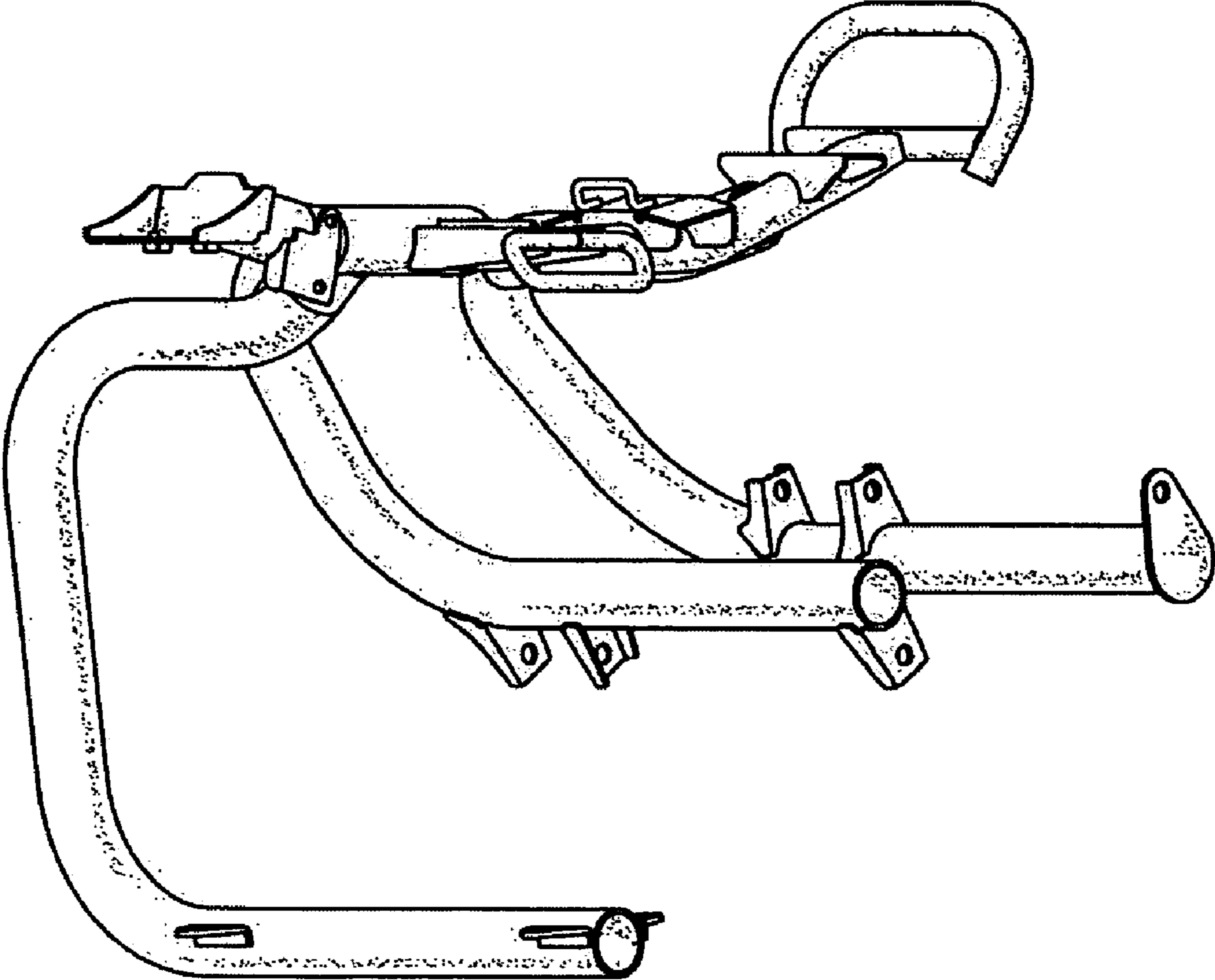

FIG. 2

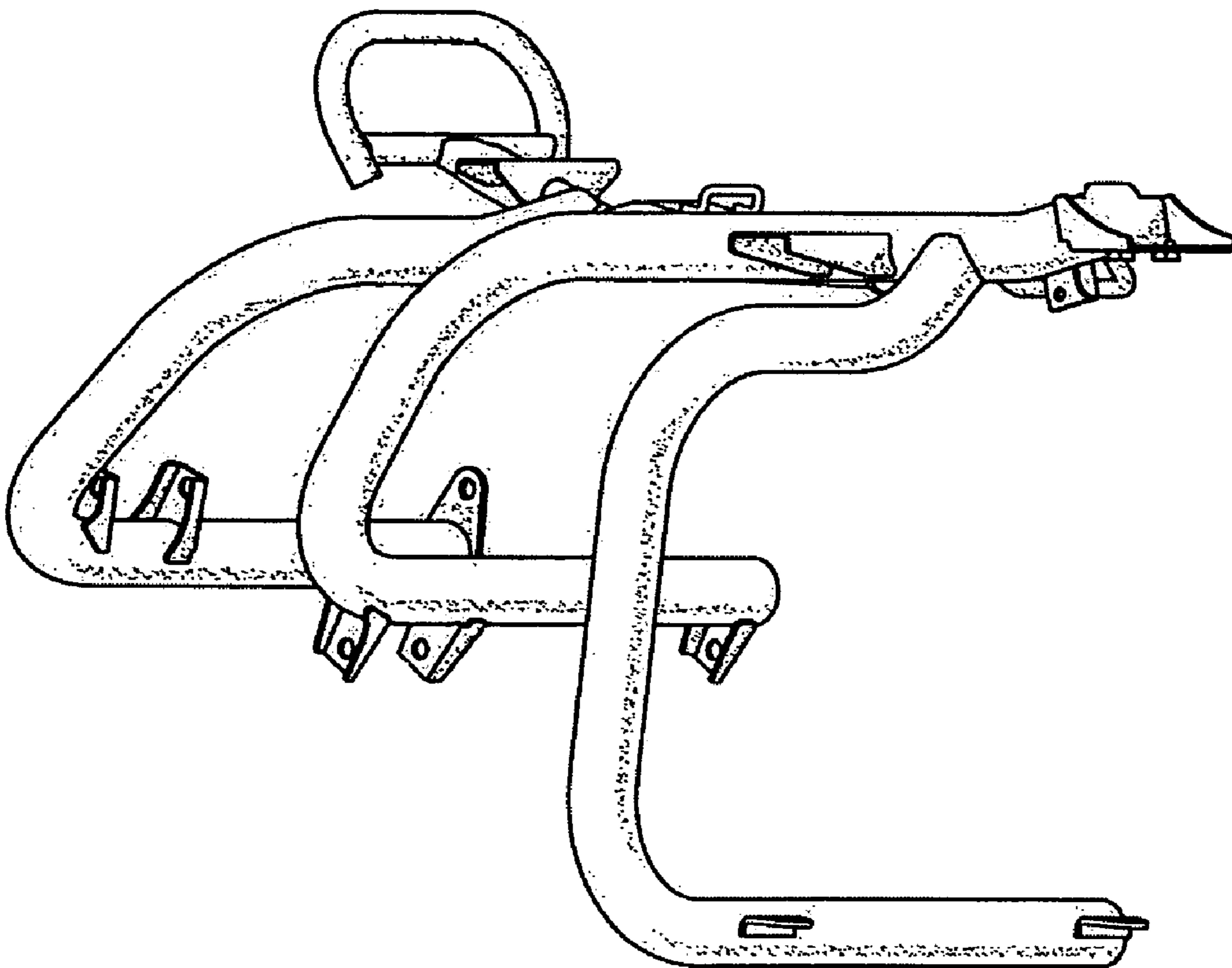

FIG. 3

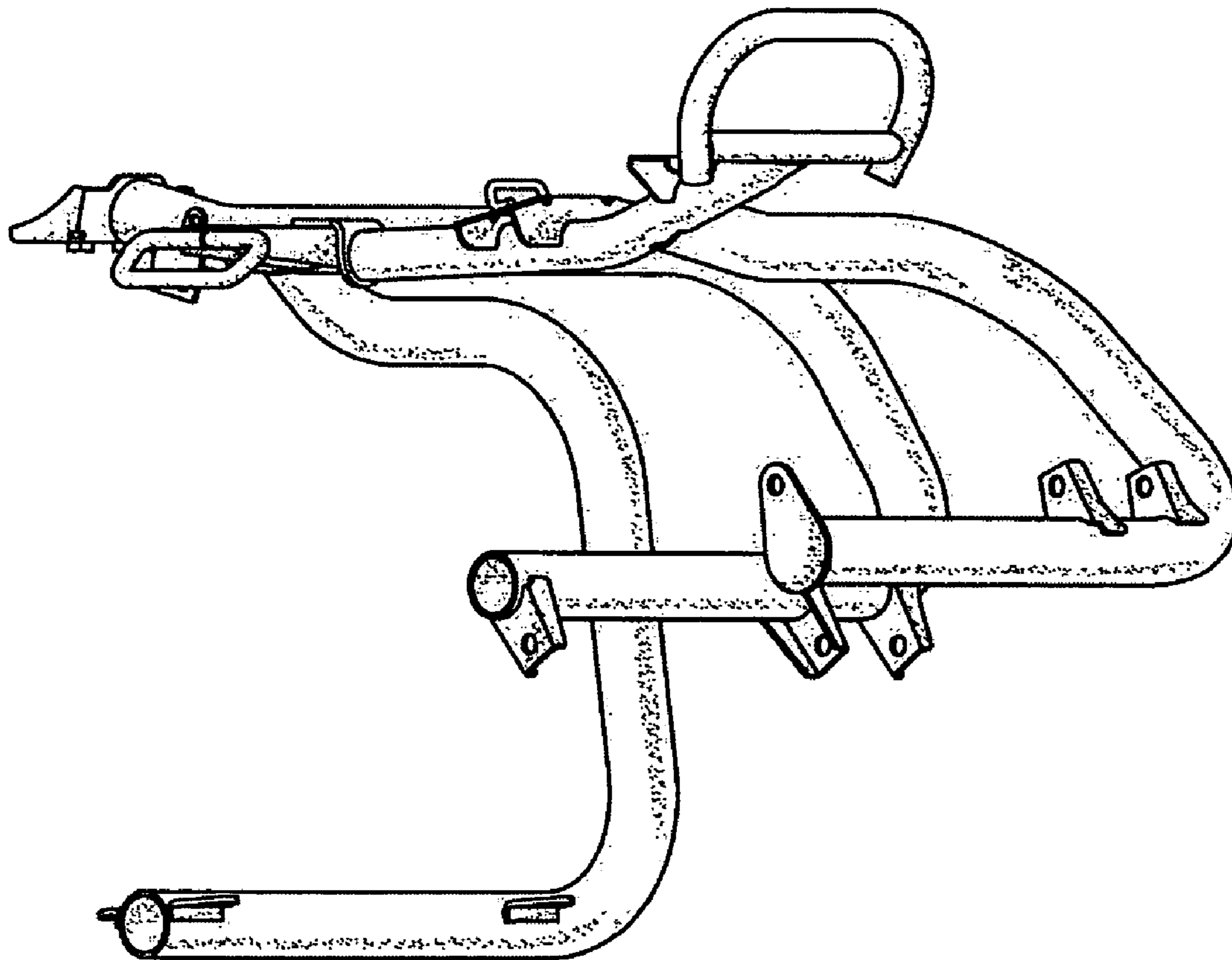

FIG. 4

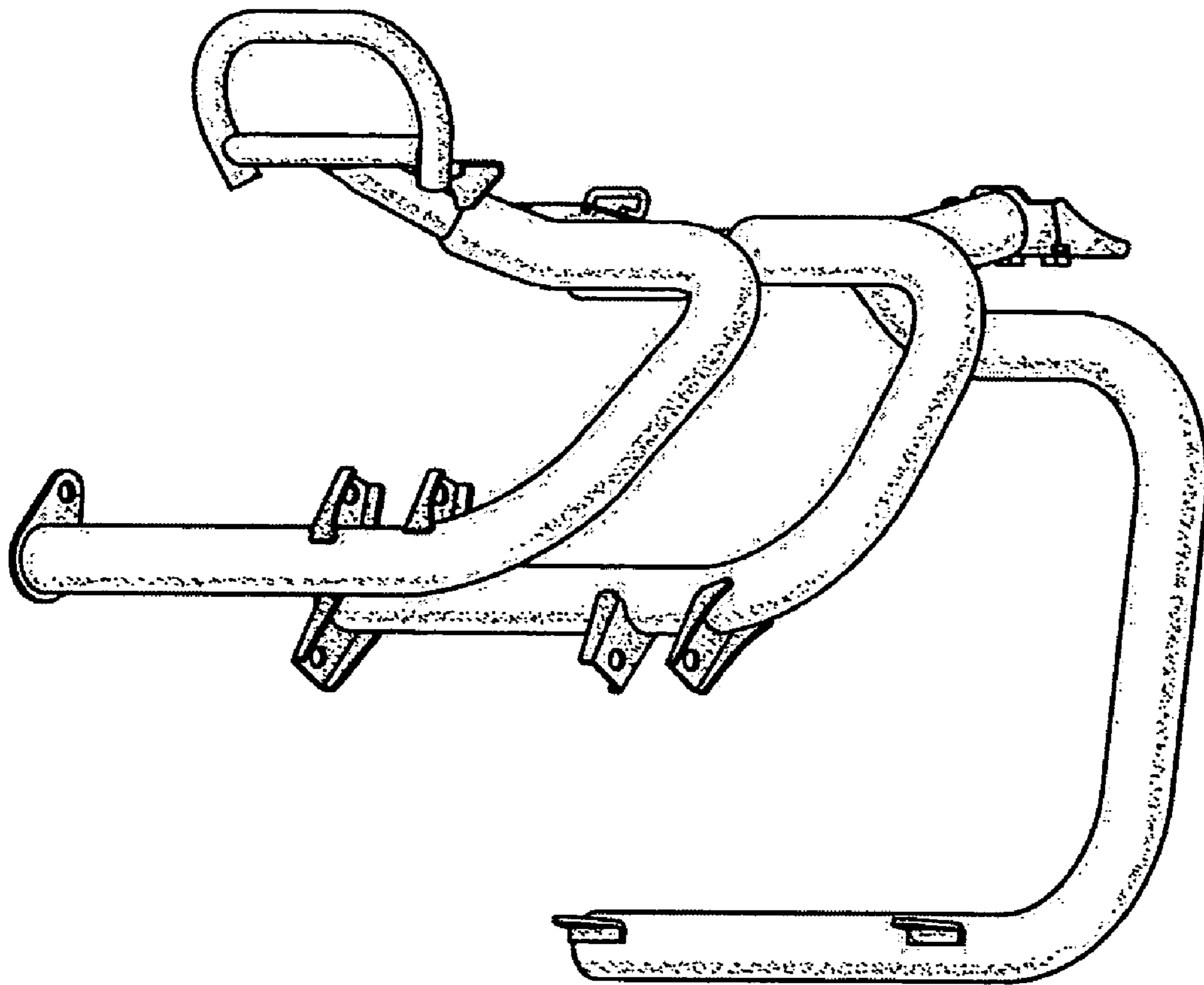

FIG. 5

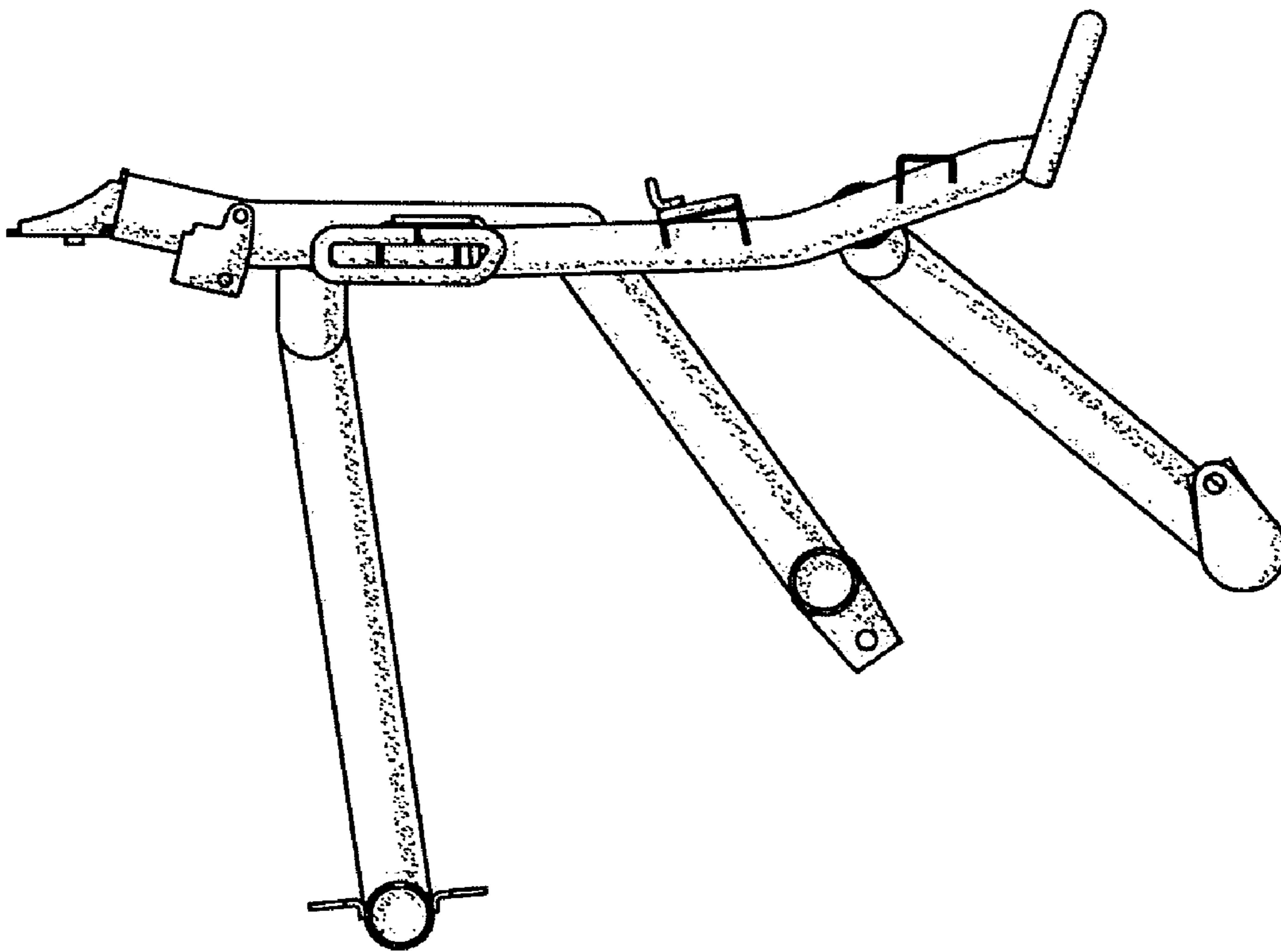

FIG. 6

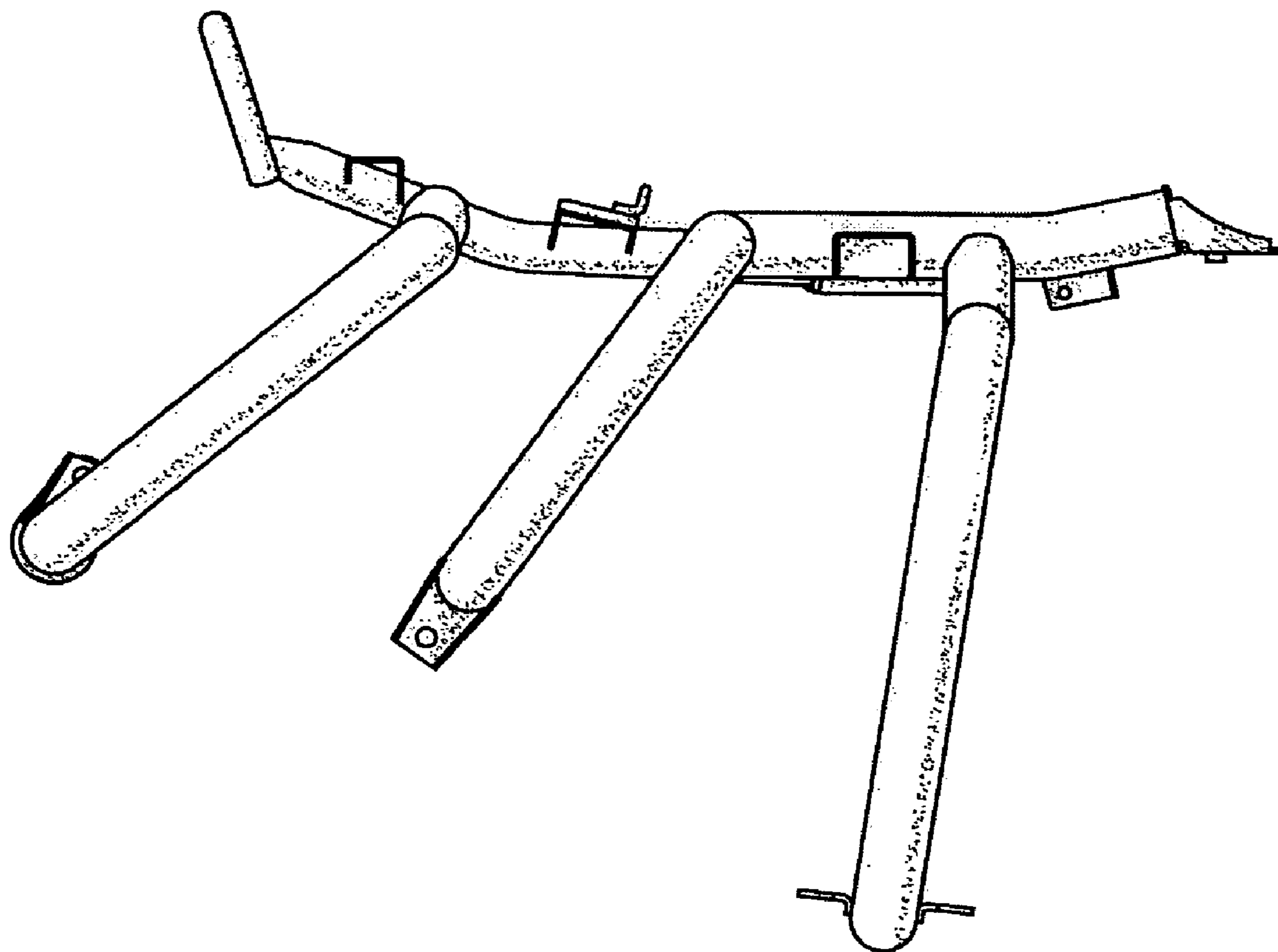

FIG. 7

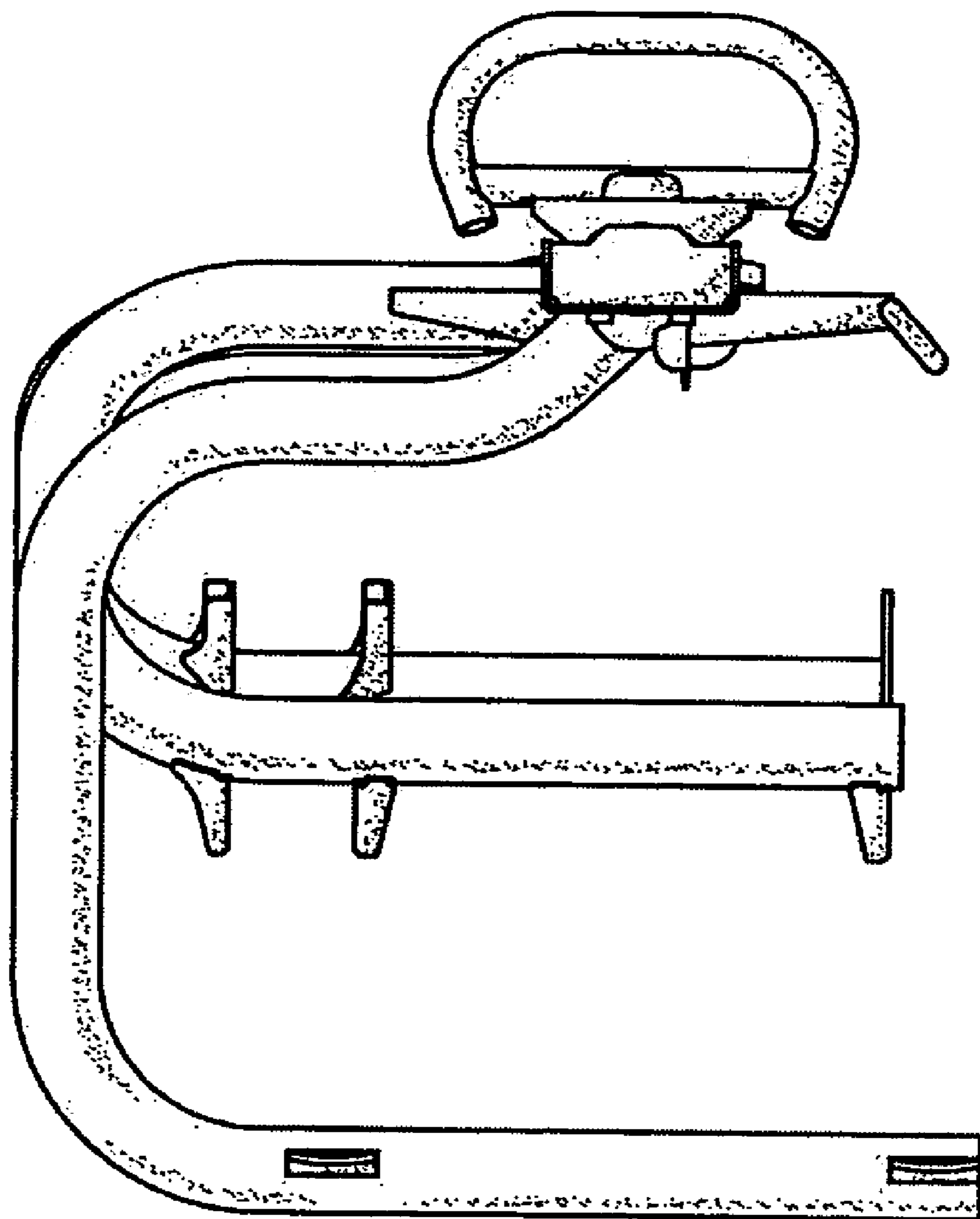

FIG. 8

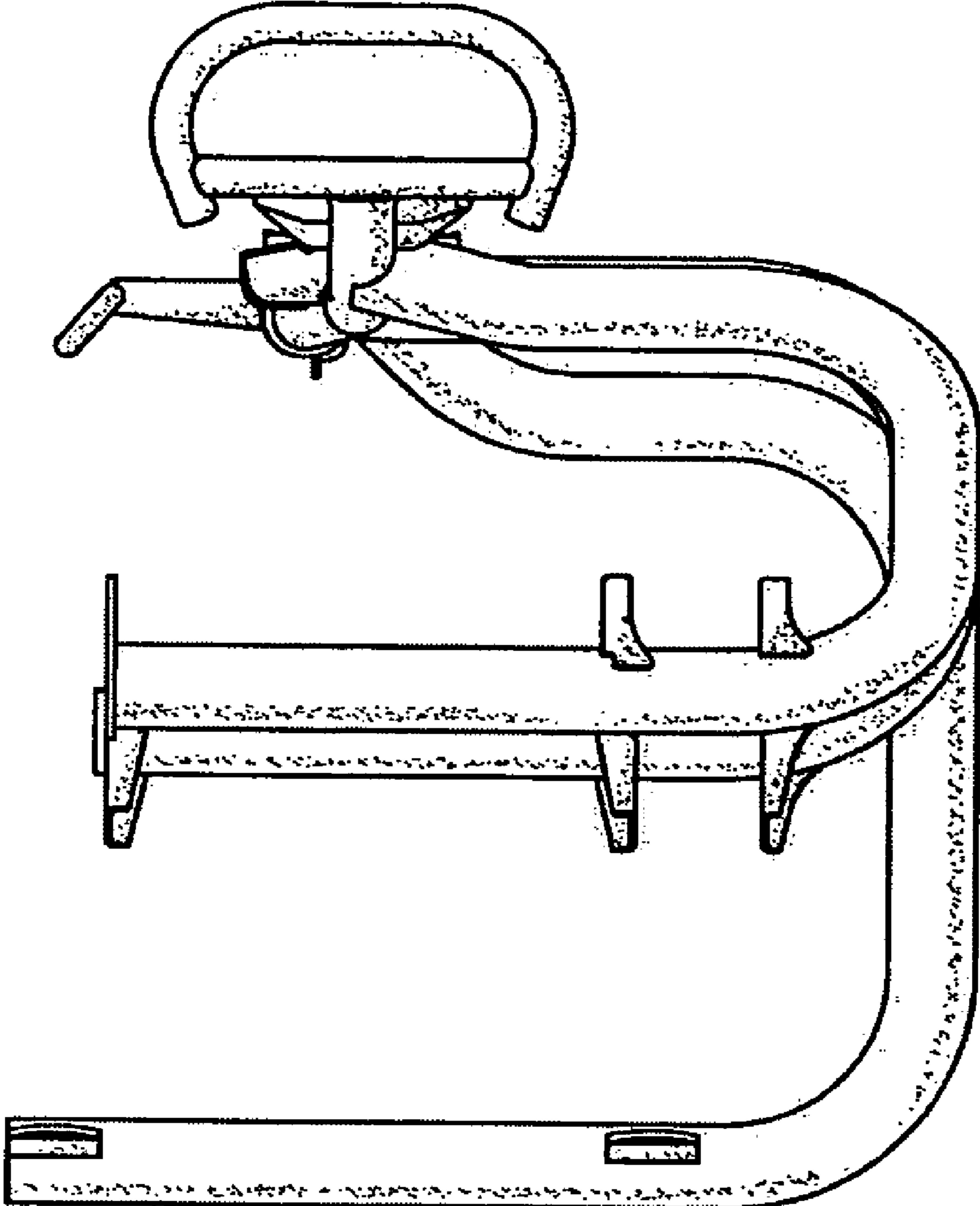

FIG. 9

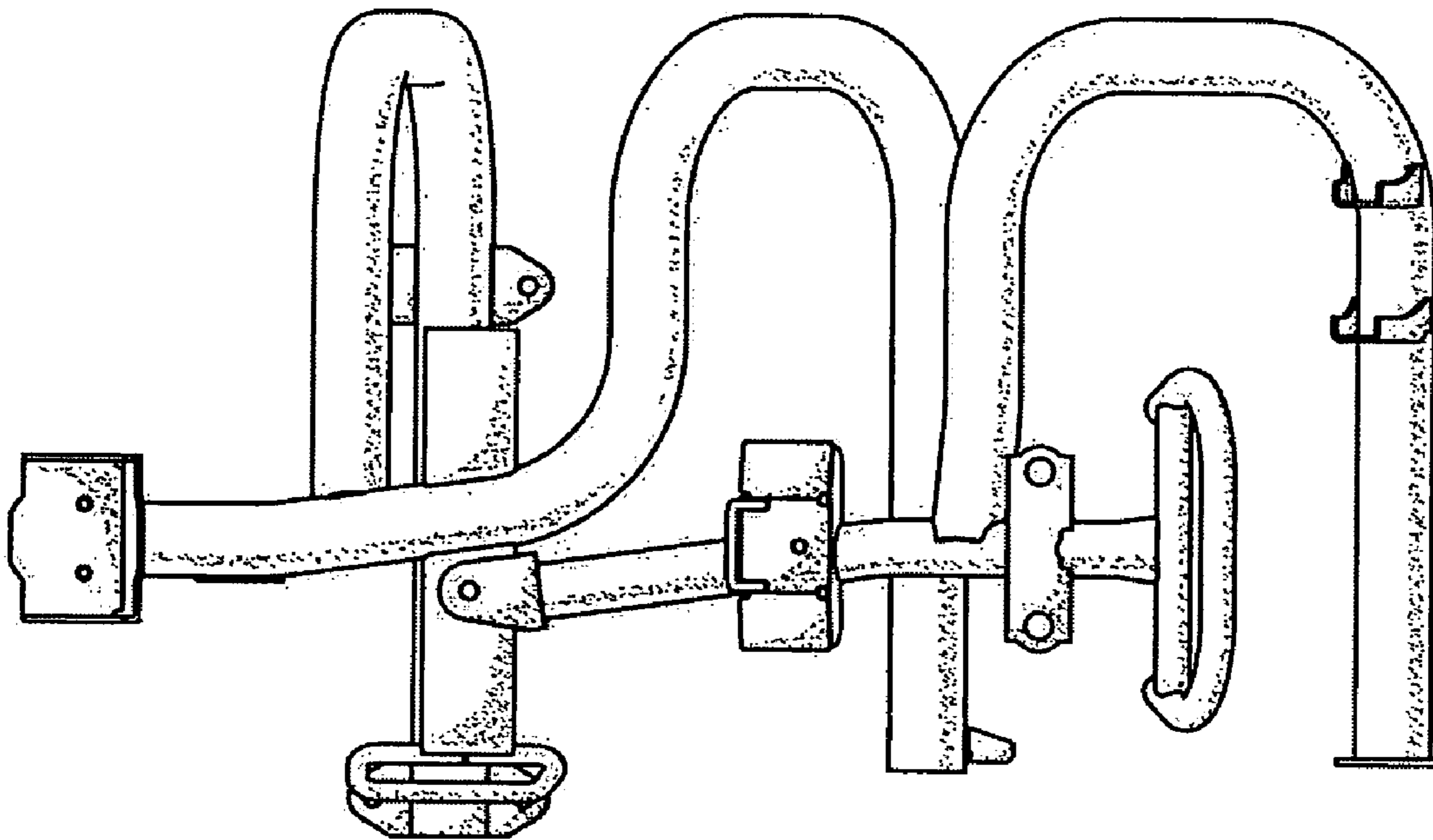

FIG. 10

