



US00D570068S

(12) **United States Design Patent**
Dukes

(10) **Patent No.:** **US D570,068 S**

(45) **Date of Patent:** **** May 27, 2008**

(54) **HAND TRUCK**

(75) Inventor: **Stephen A. Dukes**, North Baltimore,
OH (US)

(73) Assignee: **Impact Products LLC**, Toledo, OH
(US)

(**) Term: **14 Years**

(21) Appl. No.: **29/276,957**

(22) Filed: **Feb. 9, 2007**

(51) **LOC (8) Cl.** **12-02**

(52) **U.S. Cl.** **D34/17**

(58) **Field of Classification Search** D34/12-27;
280/47.131, 47.17-47.19, 47.24, 47.28, 47.27,
280/47.34, 33.996, 33.991, 33.994, 655,
280/651

See application file for complete search history.

(56) **References Cited**

U.S. PATENT DOCUMENTS

| | | | | | |
|-----------|-----|--------|--------------------|-------|------------|
| 2,738,201 | A * | 3/1956 | Spears | | 280/33.996 |
| 4,274,644 | A | 6/1981 | Taylor | | |
| 4,458,906 | A * | 7/1984 | Lamson | | 280/47.34 |
| 4,921,264 | A * | 5/1990 | Duffy | | 280/79.11 |
| D396,918 | S | 8/1998 | Golichowski et al. | | |
| D404,871 | S * | 1/1999 | Golichowski et al. | | D34/17 |
| 5,911,424 | A * | 6/1999 | Rovinsky | | 280/79.11 |
| 6,024,376 | A | 2/2000 | Golichowski et al. | | |
| 6,877,764 | B2 | 4/2005 | Sagol | | |

D523,201 S * 6/2006 Widmer D34/12
2003/0205873 A1 * 11/2003 Orozco 280/33.991

* cited by examiner

Primary Examiner—Cynthia E Ramirez

(74) *Attorney, Agent, or Firm*—Fraser Clemens Martin &
Miller LLC; J. Douglas Miller

(57) **CLAIM**

The ornamental design for a hand truck, as shown and
described.

DESCRIPTION

FIG. 1 is a perspective view of a hand truck incorporating
my new design with a handle in a first position;

FIG. 2 is a perspective view of the hand truck of FIG. 1 with
the handle in a second position;

FIG. 3 is a front elevational view thereof;

FIG. 4 is a rear elevational view thereof;

FIG. 5 is a top plan view thereof;

FIG. 6 is a bottom plan view thereof;

FIG. 7 is a left elevational view thereof; and,

FIG. 8 is a right elevational view thereof.

The ornamental design which is claimed is shown in solid
lines in the drawings. Any broken lines in the drawings are
for illustrative purposes only and form no part of the claimed
design.

1 Claim, 5 Drawing Sheets

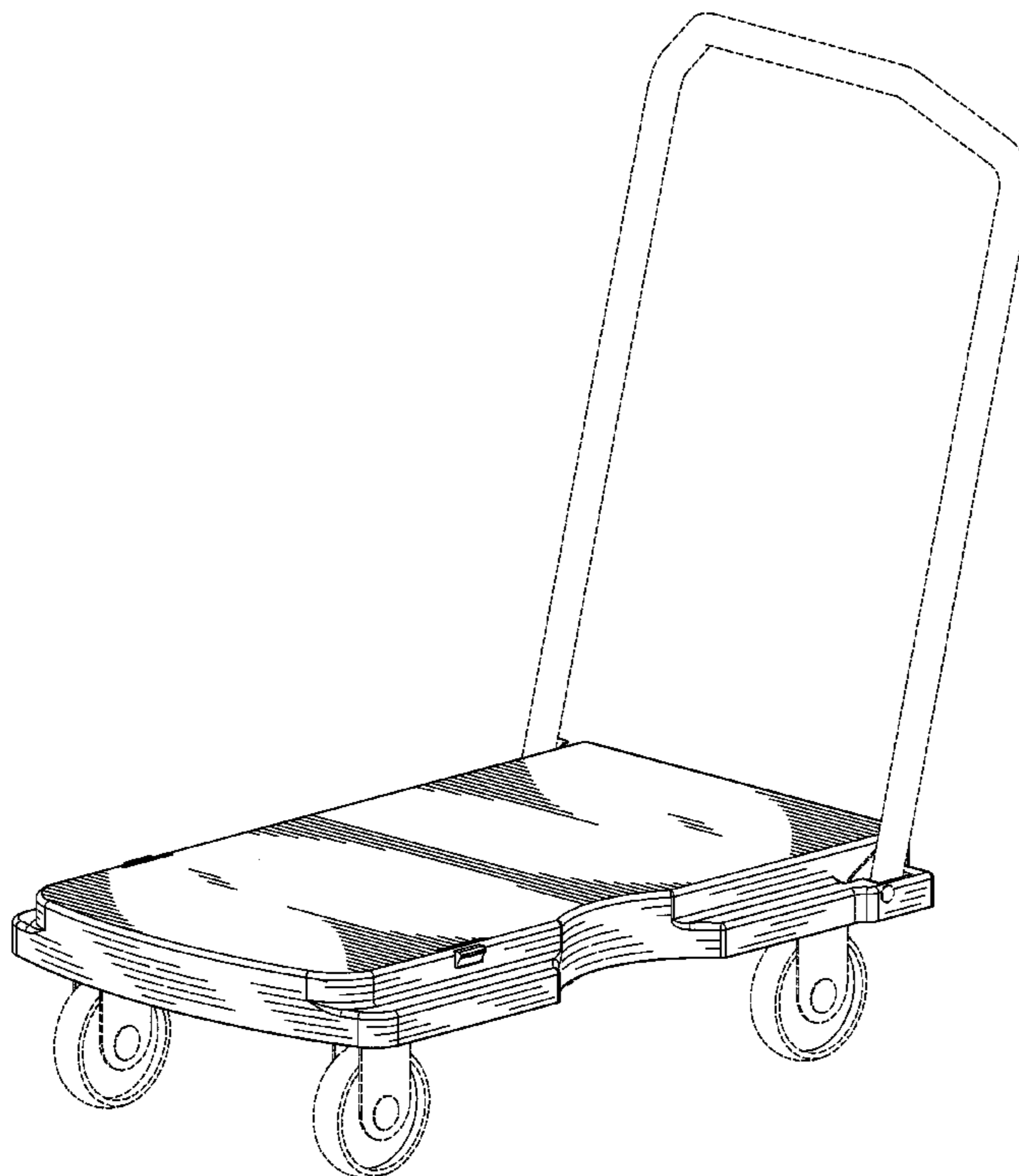

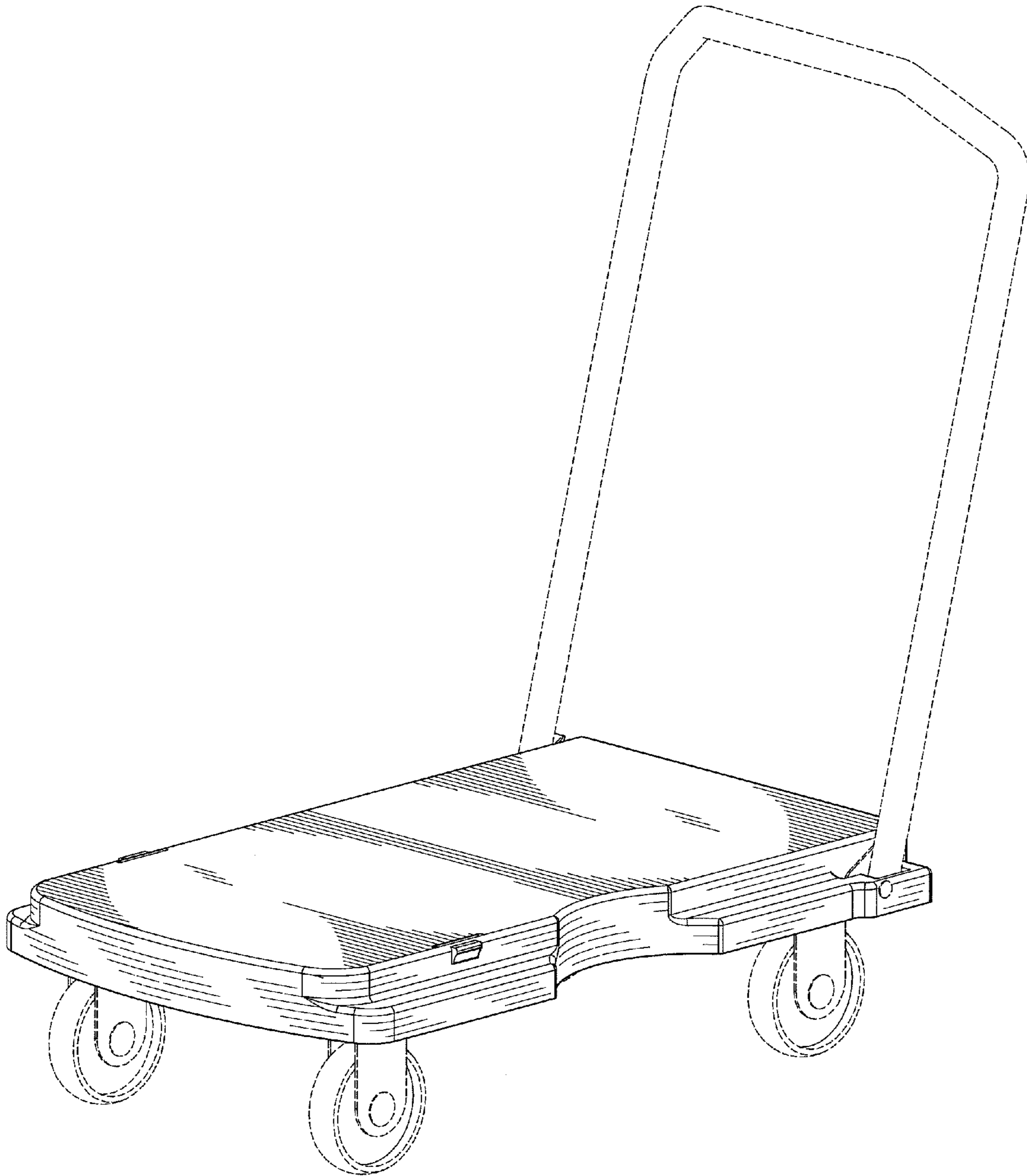

Fig. 1

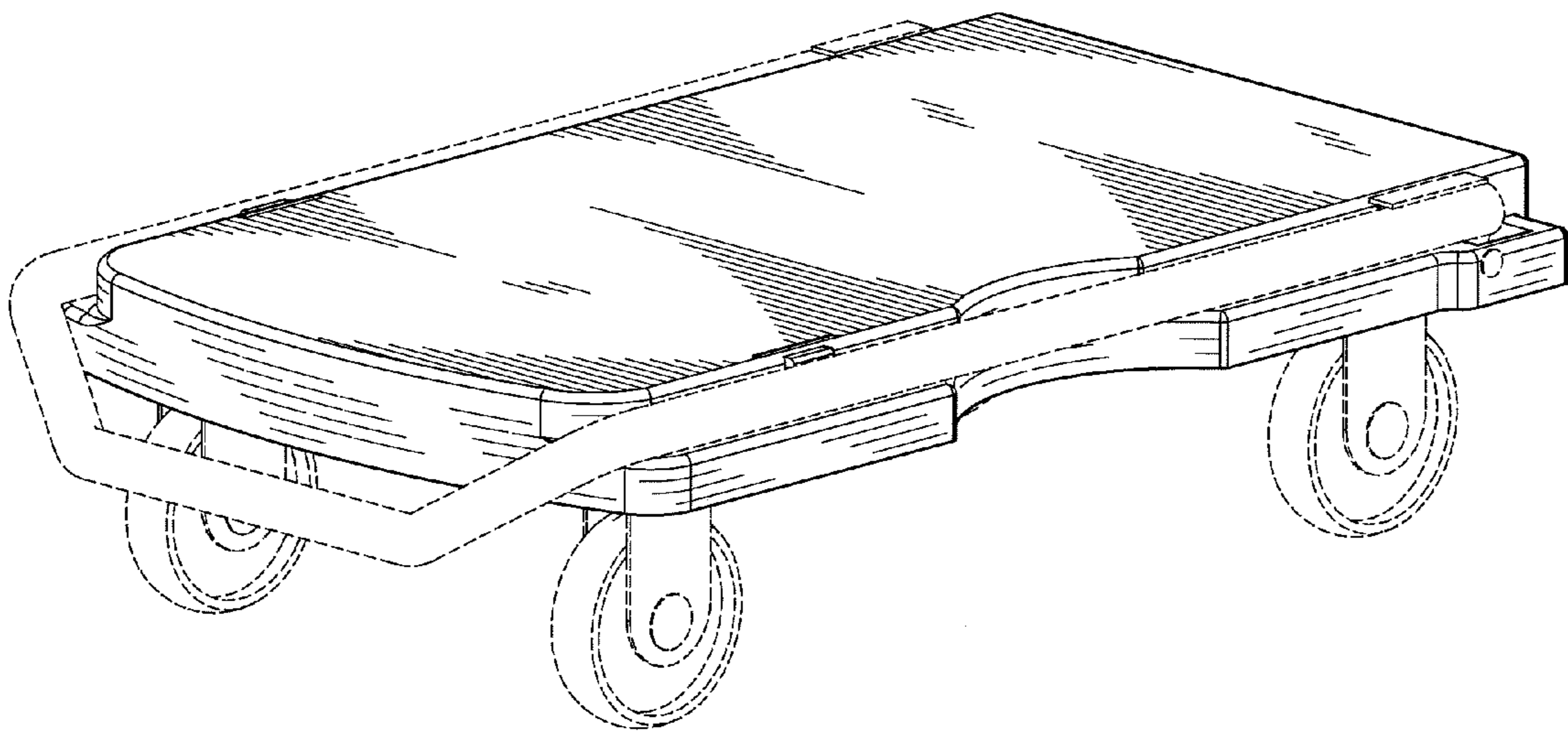

Fig. 2

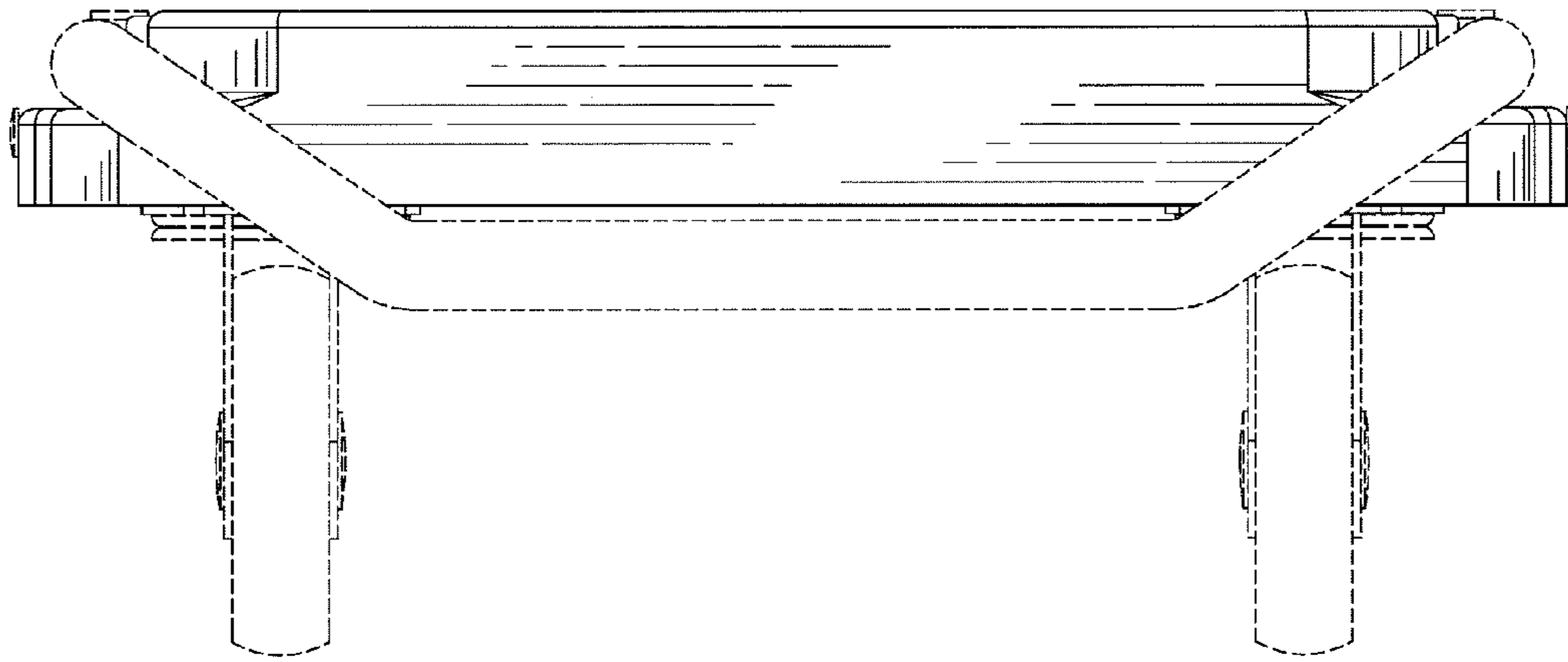

Fig. 3

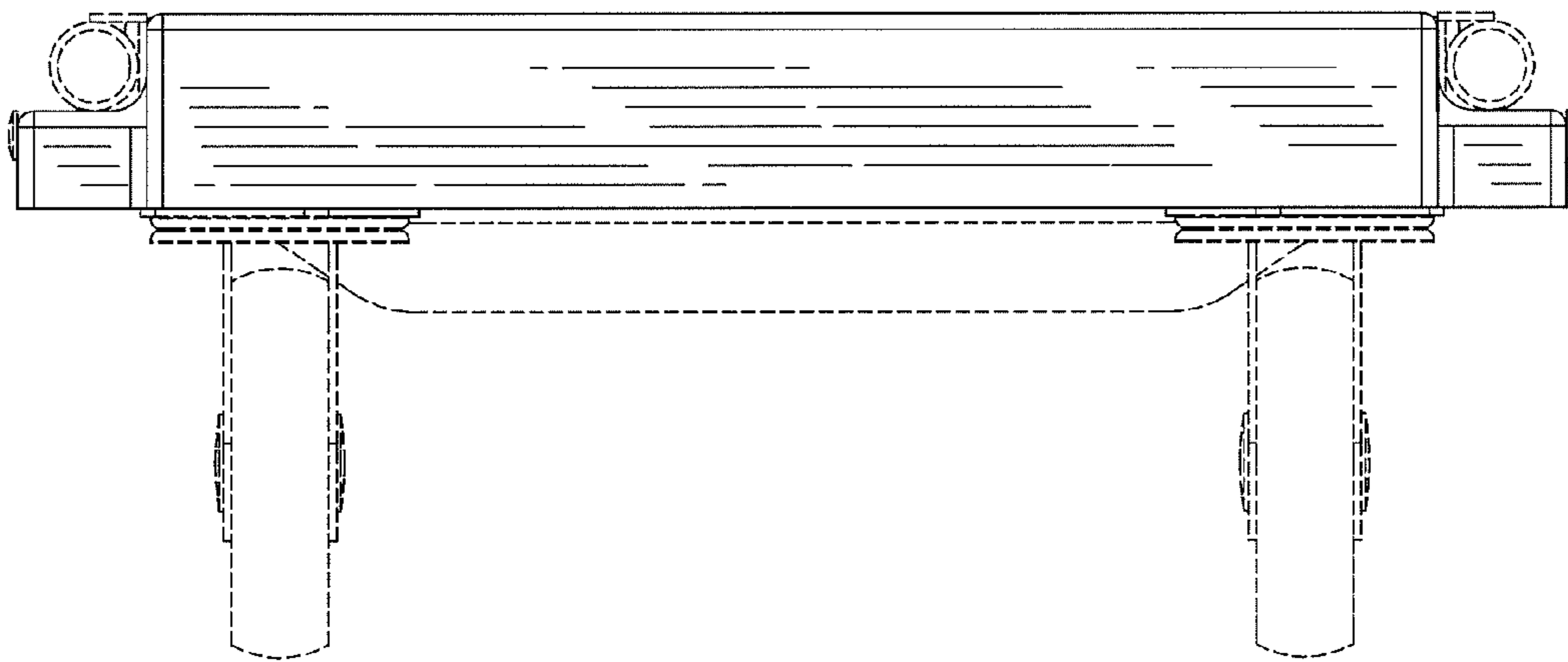

Fig. 4

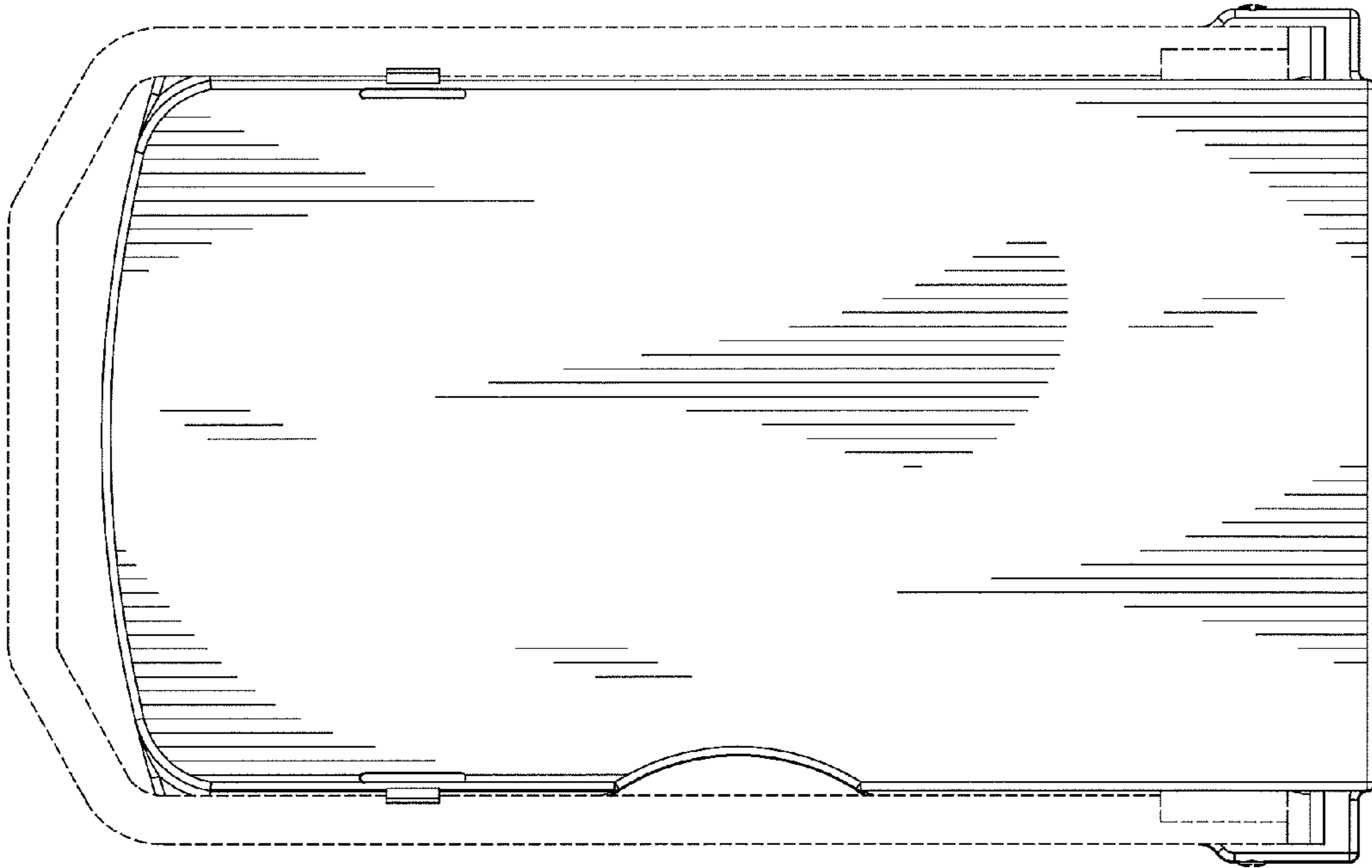

Fig. 5

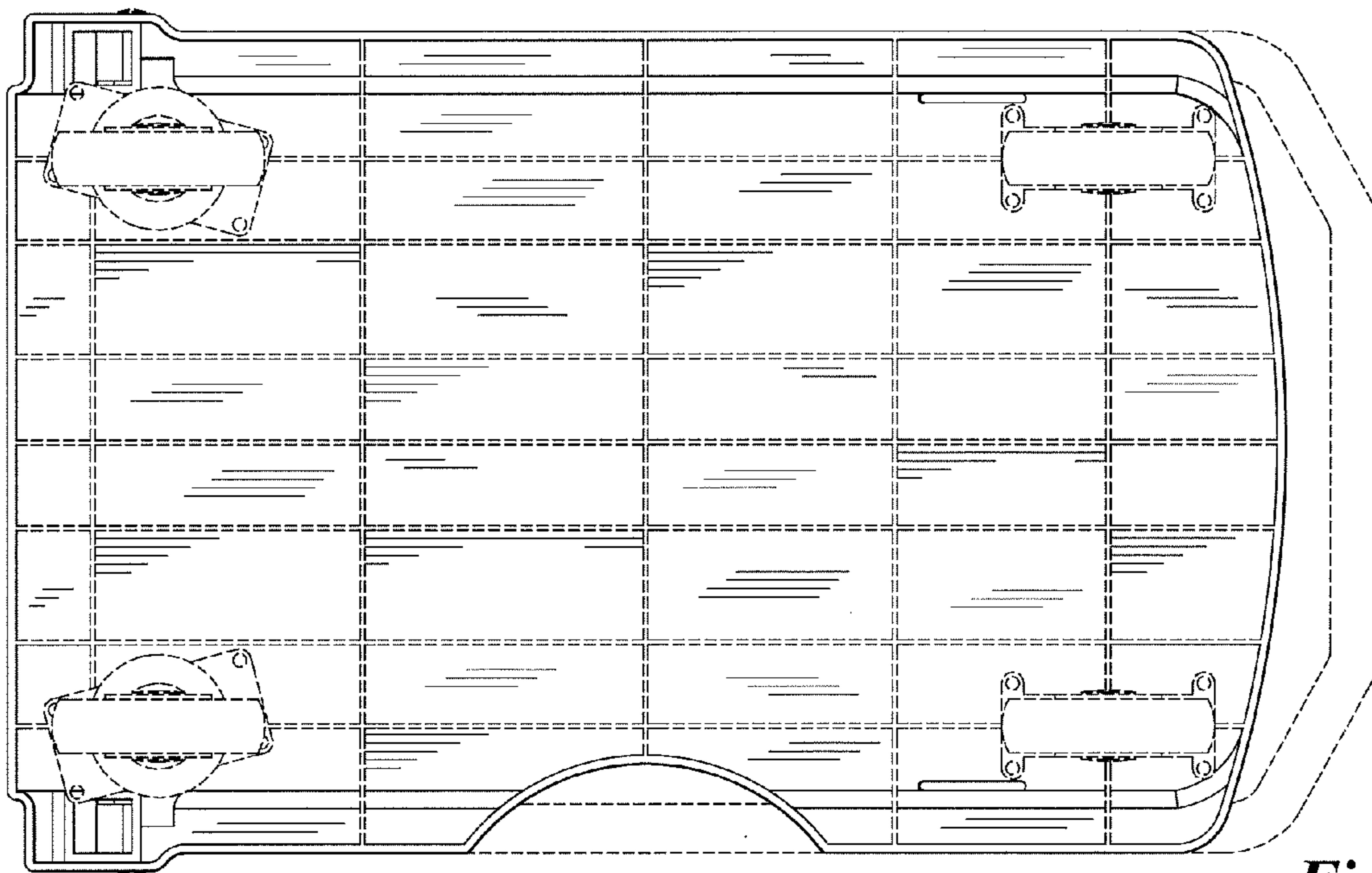

Fig. 6

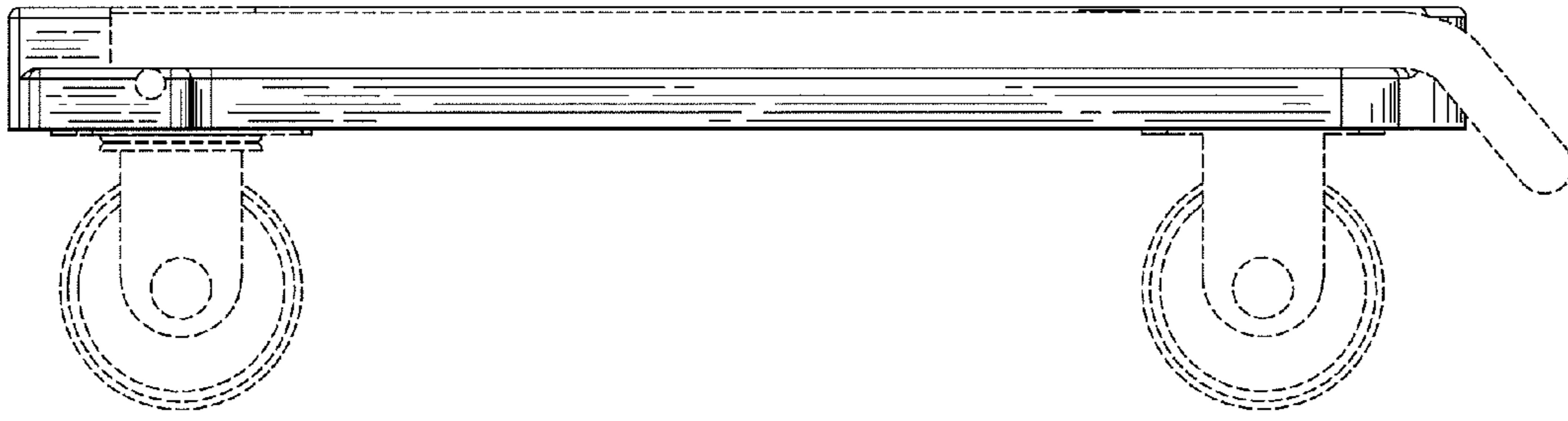

Fig. 7

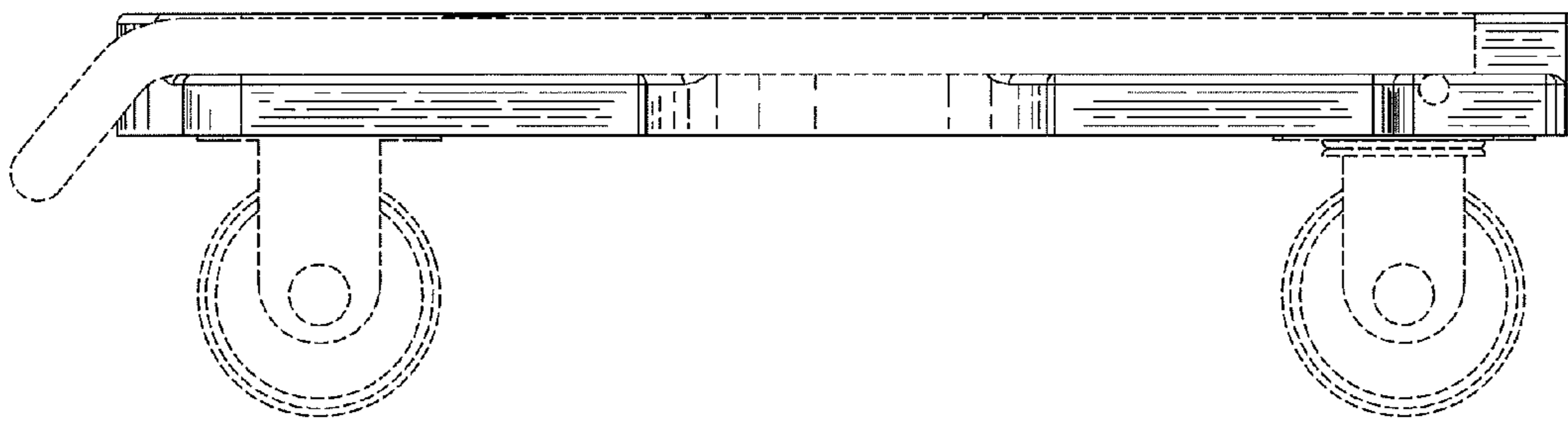

Fig. 8