

US00D570032S

(12) **United States Design Patent** (10) **Patent No.:** **US D570,032 S**  
**Lehman et al.** (45) **Date of Patent:** **\*\* May 27, 2008**

(54) **PORTION OF A HOUSING**

(75) Inventors: **Gregg Lehman**, Peachtree City, GA (US); **George Michael Drake**, Newnan, GA (US)

(73) Assignee: **Cooper Technologies Company**, Houston, TX (US)

(\*\*) Term: **14 Years**

(21) Appl. No.: **29/252,148**

(22) Filed: **Jan. 19, 2006**

(51) **LOC (8) Cl.** ..... **26-99**

(52) **U.S. Cl.** ..... **D26/118**

(58) **Field of Classification Search** ..... D26/72,  
D26/63, 85, 28, 124, 118, 65, 60, 40, 41,  
D26/42, 80, 87, 68, 67, 37, 49, 74, 77, 86,  
D26/88, 89, 93, 103, 104, 105, 113, 114,  
D26/119, 122, 123, 128, 138, 142, 143, 152;  
362/365, 96, 147, 151, 153, 217, 643, 654,  
362/257, 290, 296, 297, 301, 302, 309, 317,  
362/341, 342, 343, 347, 348, 349, 362, 364,  
362/395, 404, 405, 410, 441; 126/258  
See application file for complete search history.

(56) **References Cited**

**U.S. PATENT DOCUMENTS**

D263,340 S *	3/1982	Budnovitch et al.	.....	D26/67
D382,662 S *	8/1997	Shalvi	.....	D26/68
D389,938 S *	1/1998	Pink et al.	.....	D26/68
D427,928 S	7/2000	Hiller et al.		
D428,352 S	7/2000	Hiller et al.		
D431,092 S	9/2000	Hiller et al.		
D433,771 S	11/2000	Hiller et al.		
D434,165 S	11/2000	Hiller et al.		
D435,923 S	1/2001	Hiller et al.		
D435,924 S	1/2001	Hiller et al.		

D485,930 S *	1/2004	Chen	.....	D26/67
D488,576 S *	4/2004	Chen	.....	D26/67
D497,022 S *	10/2004	Bucher et al.	.....	D26/67
D506,280 S *	6/2005	Chen	.....	D26/67
2002/0191402 A1 *	12/2002	Leen	.....	362/362

**OTHER PUBLICATIONS**

Catalog page from Regent's Security Floodlight Systems, RFM181B Series, published as early as Mar. 2004.  
Four digital photos of the Regent's Security Floodlight Systems RFM181B, published as early as Mar. 2004.  
Catalog page from Regent Security Floodlight Systems, RFM182B Series, published as early as Mar. 2004.  
Catalog page from Regent, MTL27X Series Surveillance All Metal, published as early as 2000.

\* cited by examiner

*Primary Examiner*—Freda S. Nunn  
*Assistant Examiner*—Kevin K Rudzinski  
(74) *Attorney, Agent, or Firm*—SAIDMAN DesignLaw Group

(57) **CLAIM**

The ornamental design for a portion of a housing, as shown and described.

**DESCRIPTION**

FIG. 1 is a front, perspective view of a portion of a housing showing our new design;

FIG. 2 is a front view thereof;

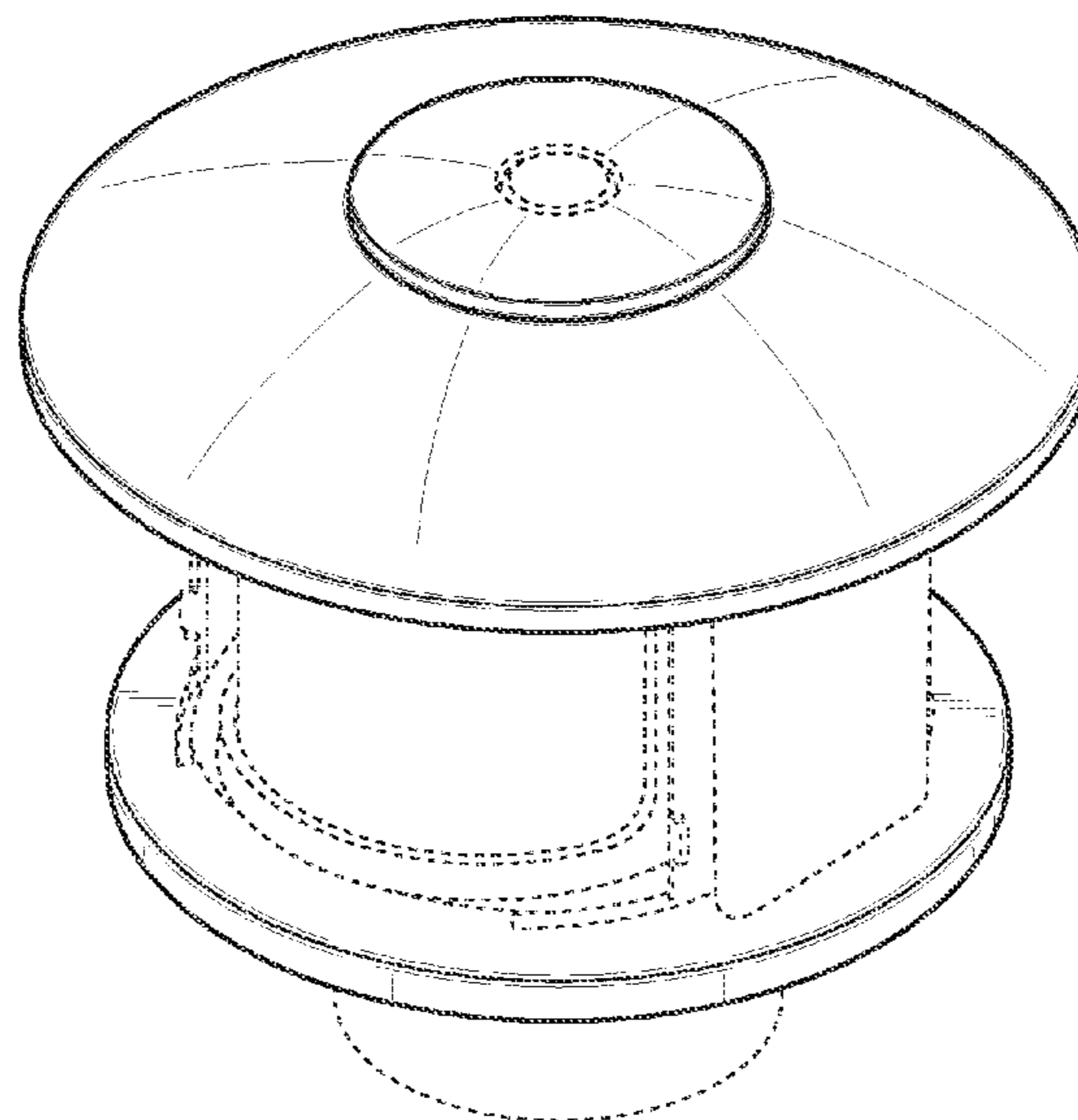
FIG. 3 is a rear view thereof;

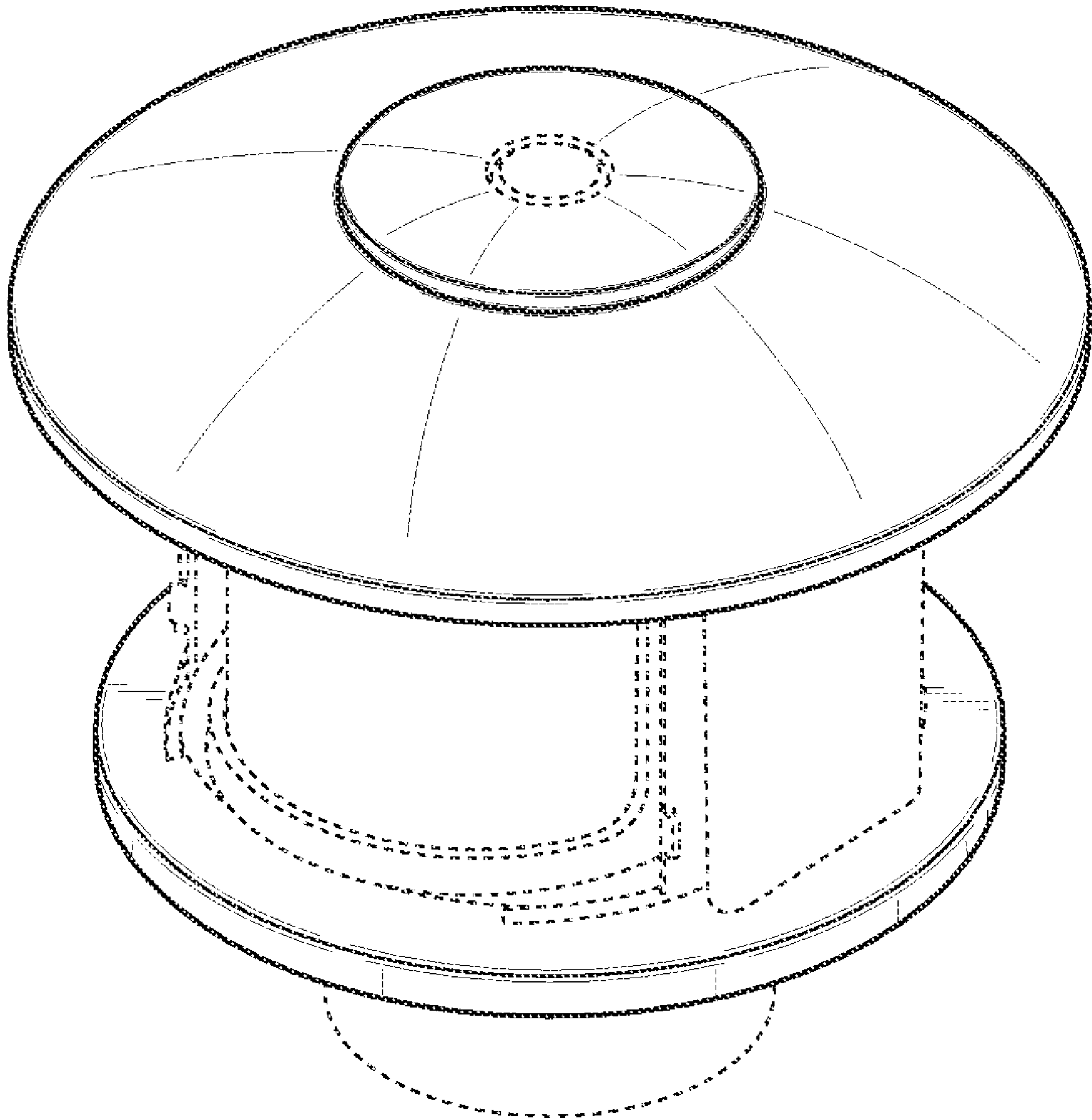
FIG. 4 is a right side view thereof, the left side view being a mirror image; and,

FIG. 5 is a top view thereof.

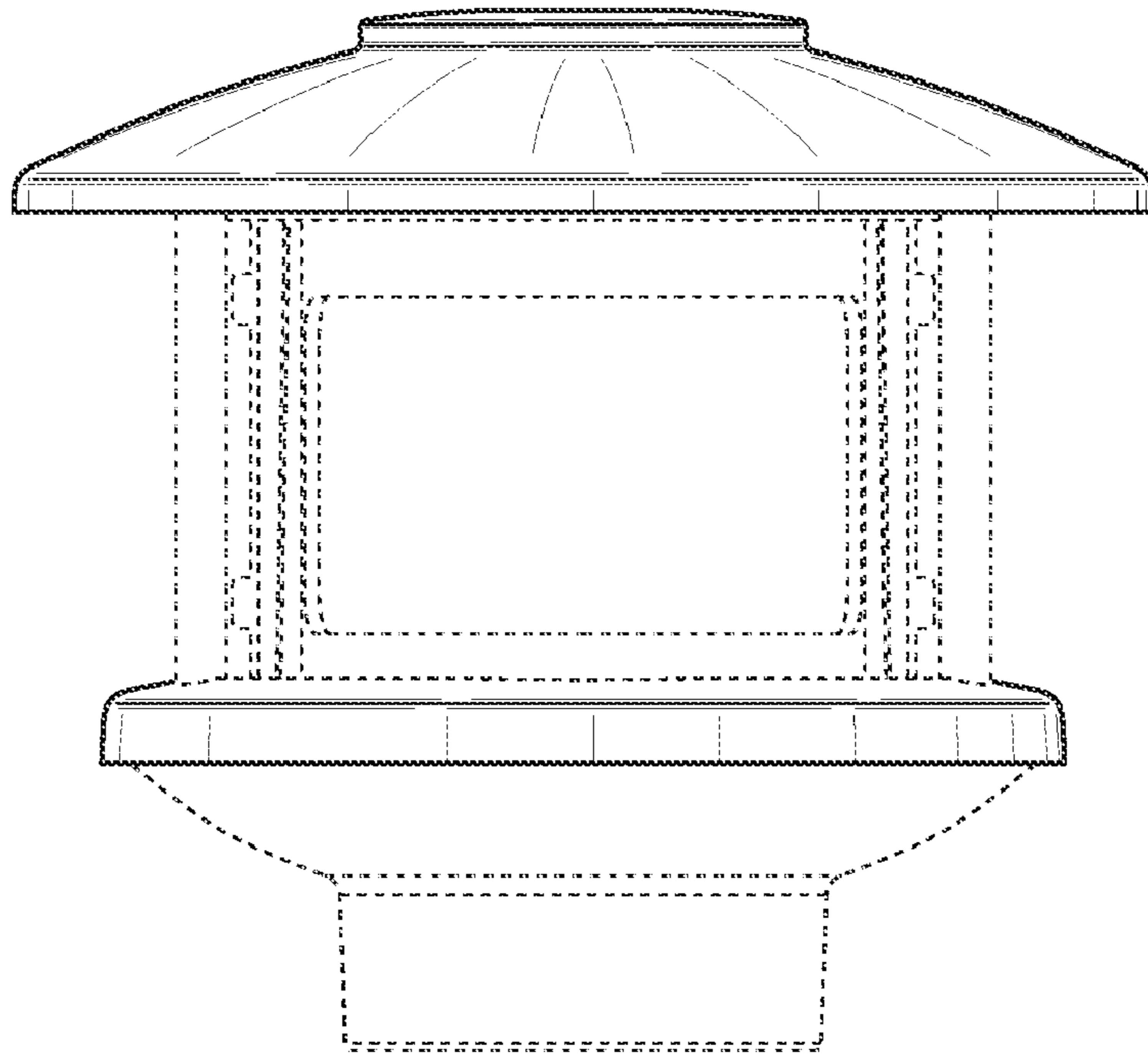
The broken lines form no part of the claimed design.

**1 Claim, 3 Drawing Sheets**

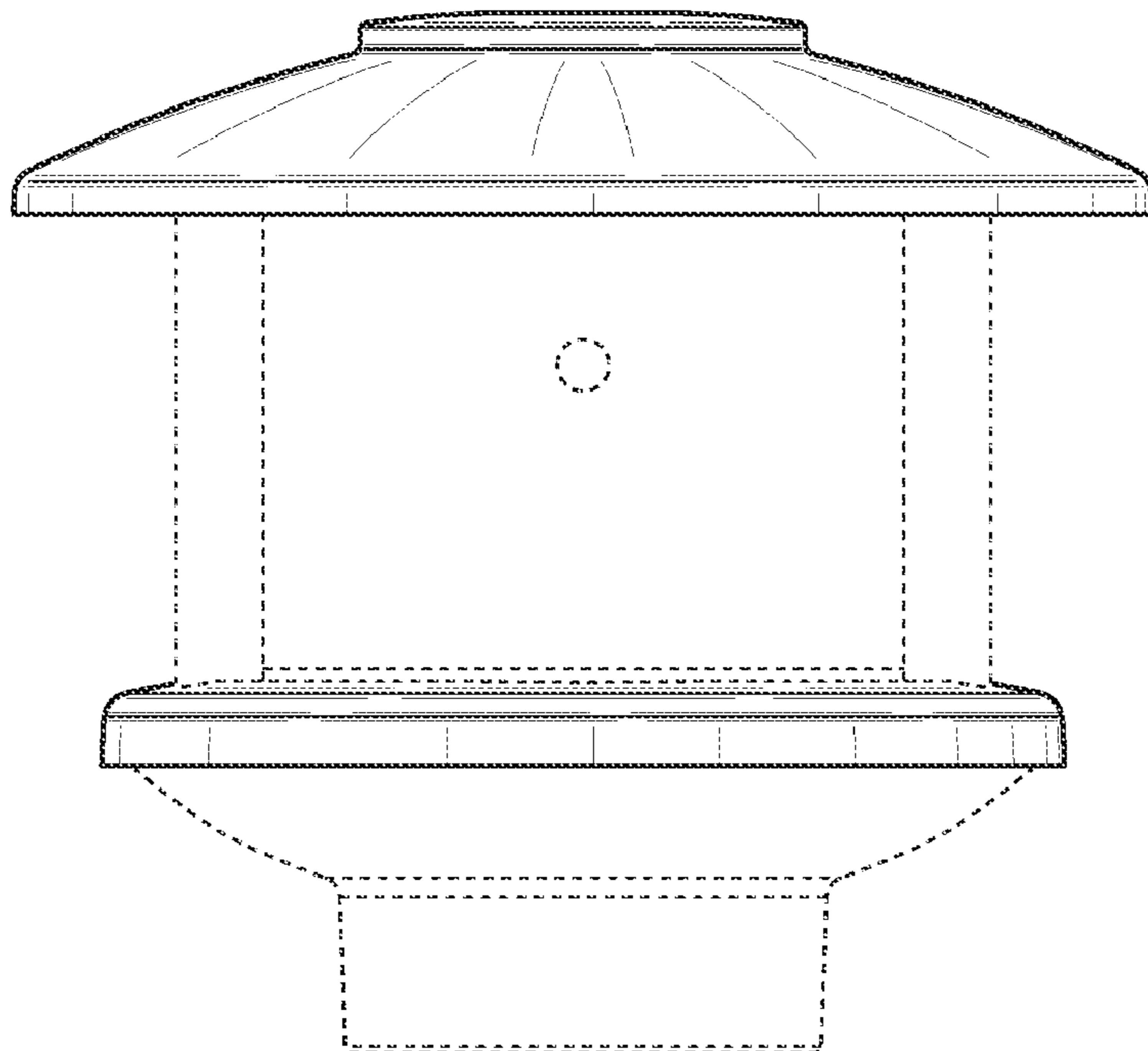




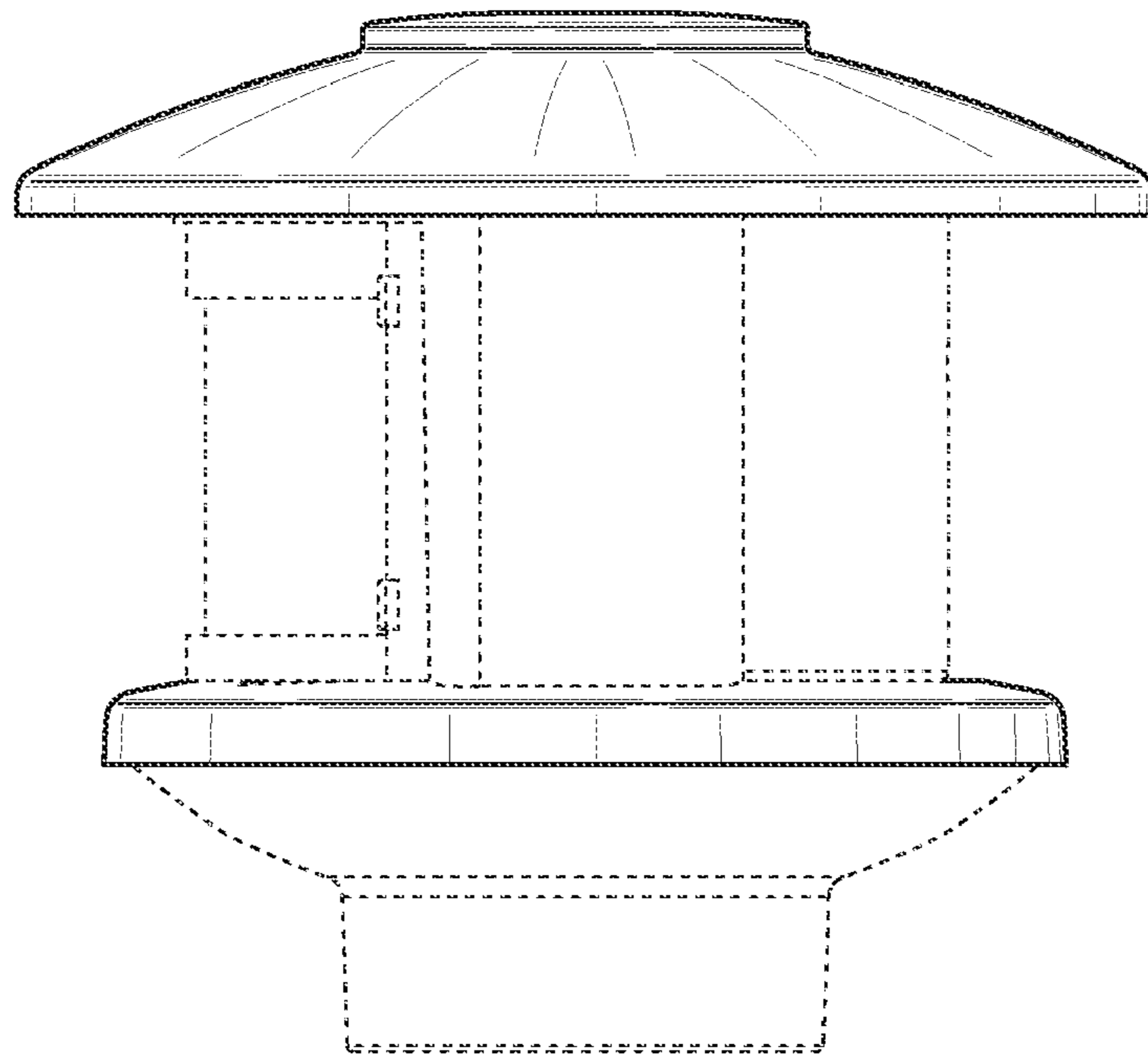
*Fig. 1*



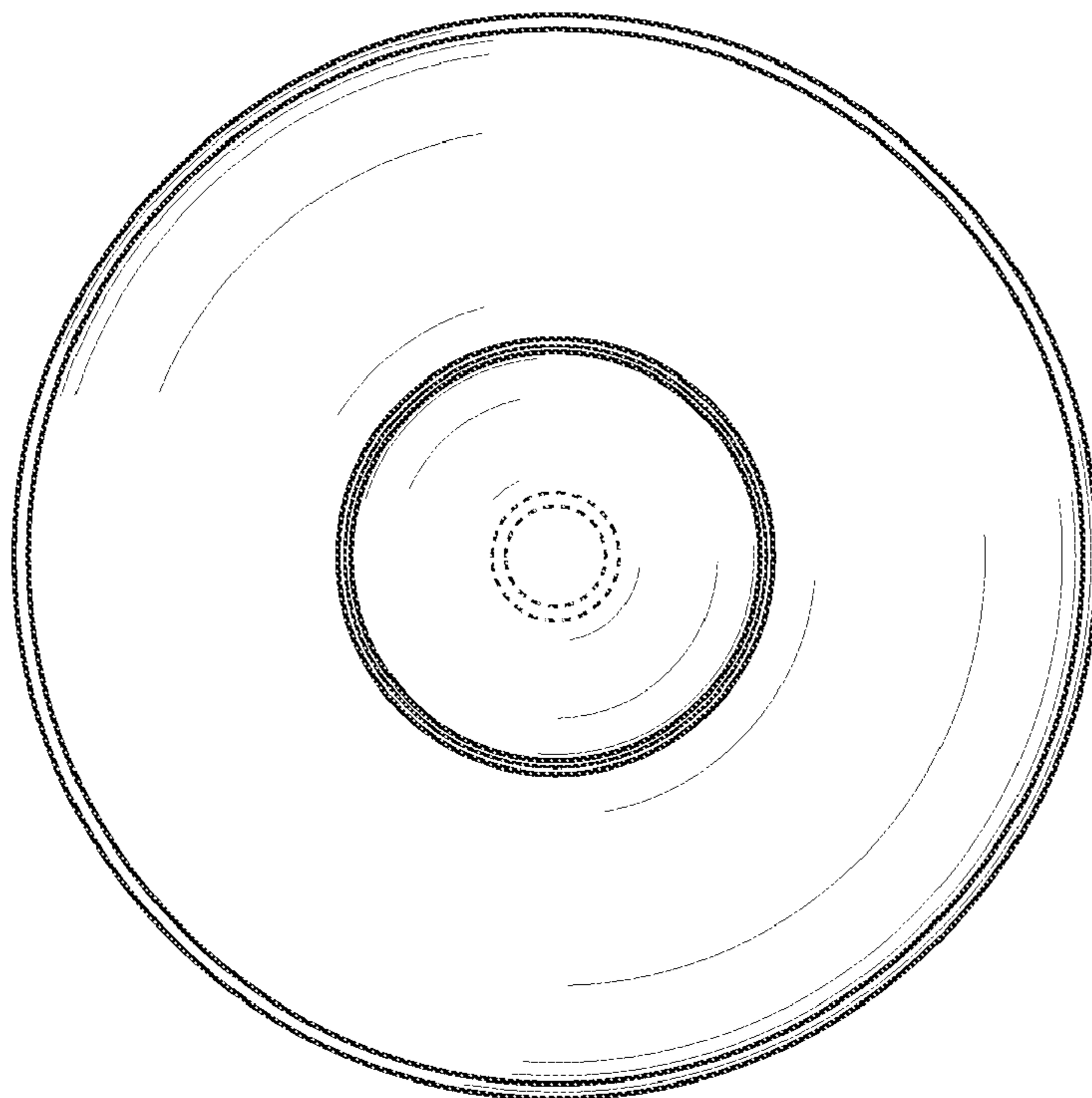
*Fig. 2*



*Fig. 3*



*Fig. 4*



*Fig. 5*