



US00D56997S

(12) **United States Design Patent**  
**McPherson**

(10) **Patent No.:** **US D569,997 S**

(45) **Date of Patent:** **\*\* May 27, 2008**

(54) **SLOTTED I-BEAM**

(75) Inventor: **Gary M. McPherson**, Wrightstown, PA (US)

(73) Assignee: **Load Rite Trailers, Inc.**, Fairless Hills, PA (US)

(\*\*) Term: **14 Years**

(21) Appl. No.: **29/278,955**

(22) Filed: **Apr. 16, 2007**

(51) **LOC (8) Cl.** ..... **25-01**

(52) **U.S. Cl.** ..... **D25/119; D25/121**

(58) **Field of Classification Search** ..... D25/119, D25/121; 52/729.1, 729.2

See application file for complete search history.

(56) **References Cited**

**U.S. PATENT DOCUMENTS**

1,377,891 A	5/1921	Knight	
4,005,941 A	2/1977	Laborde	
4,159,604 A	7/1979	Burrell	
4,285,095 A	8/1981	Janson	
4,584,809 A	4/1986	Stanford	
5,233,807 A *	8/1993	Spera	52/729.1
5,634,300 A	6/1997	Huebner et al.	
5,930,966 A *	8/1999	Wood et al.	52/364

D518,900 S *	4/2006	Barnett	.....	D25/119
2003/0205019 A1	11/2003	Becker et al.		
2005/0284078 A1	12/2005	Marsland		

\* cited by examiner

*Primary Examiner*—Doris Clark

(74) *Attorney, Agent, or Firm*—Paul & Paul

(57) **CLAIM**

The ornamental design for a slotted I-beam, as shown and described.

**DESCRIPTION**

FIG. 1 is perspective view of the slotted I-beam of the present invention;

FIG. 2 is a first end view of the slotted I-beam, with the opposite end view being a mirror image thereof;

FIG. 3 is a right side elevation view of the slotted I-beam, with the opposite, left side view being a mirror image thereof;

FIG. 4 is a top plan view of the slotted I-beam; and,

FIG. 5 is bottom plan view of the slotted I-beam.

The broken lines shown in the center of the slotted I-beam indicate indeterminate length.

**1 Claim, 3 Drawing Sheets**

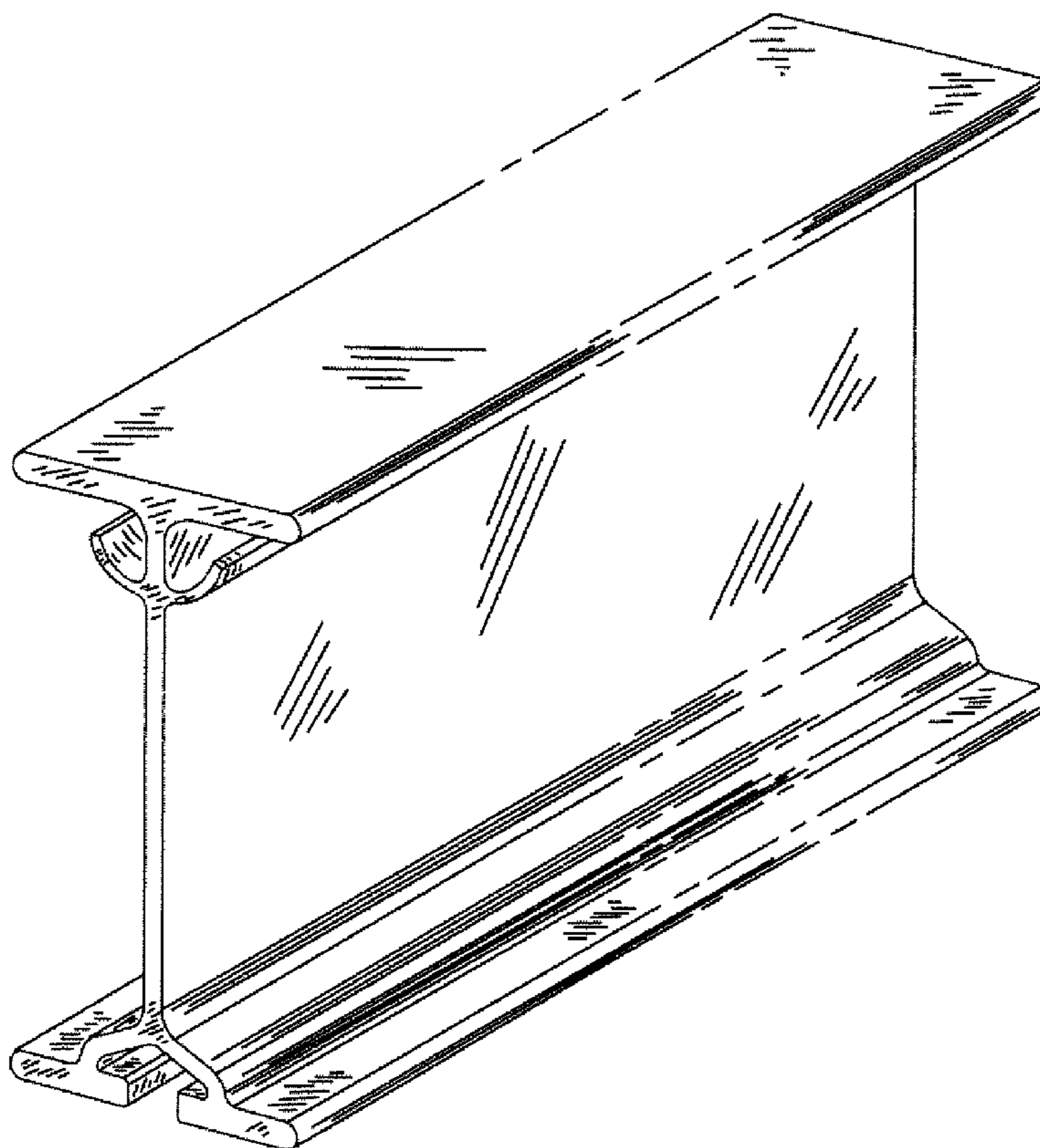

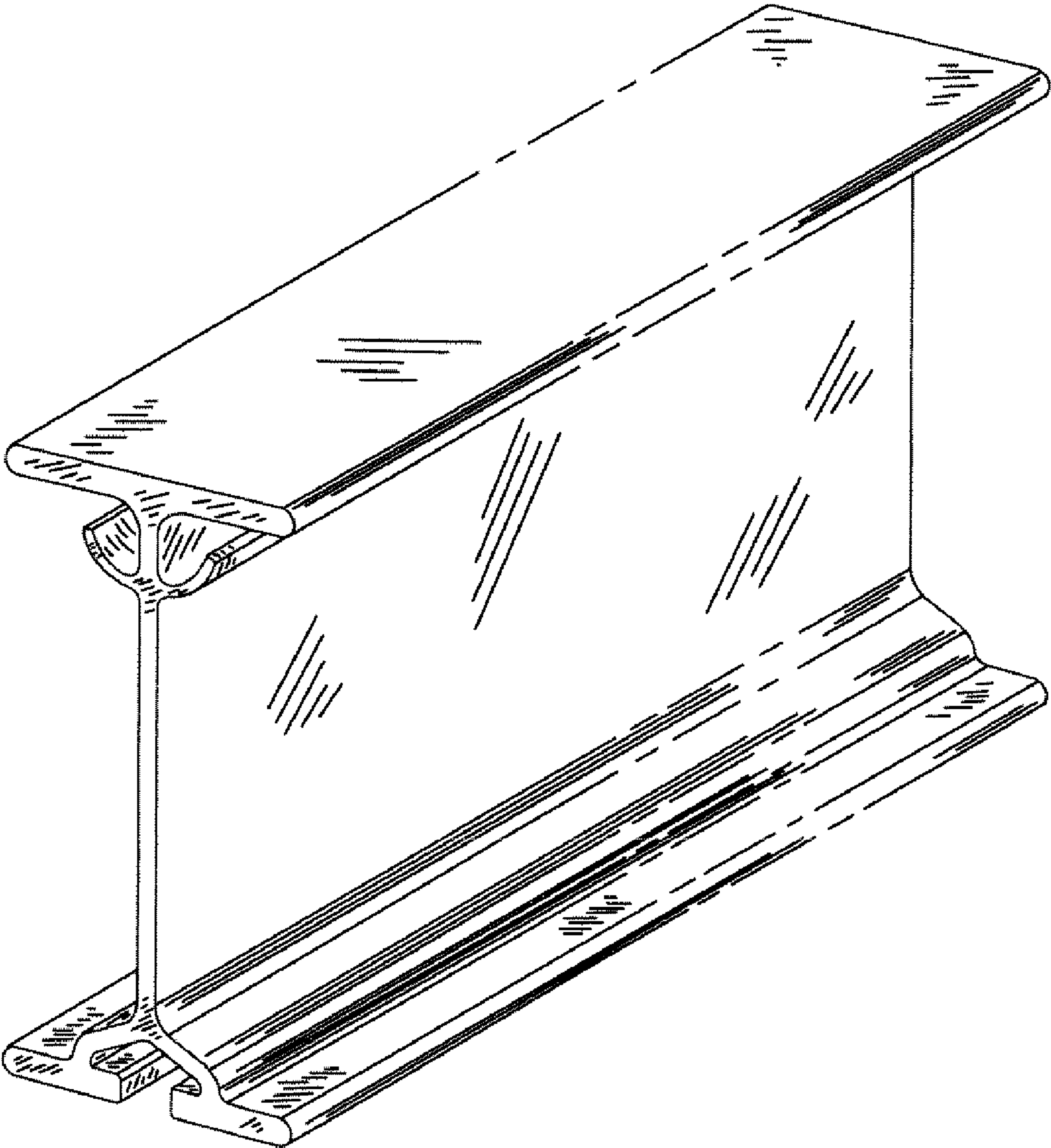

Fig. 1

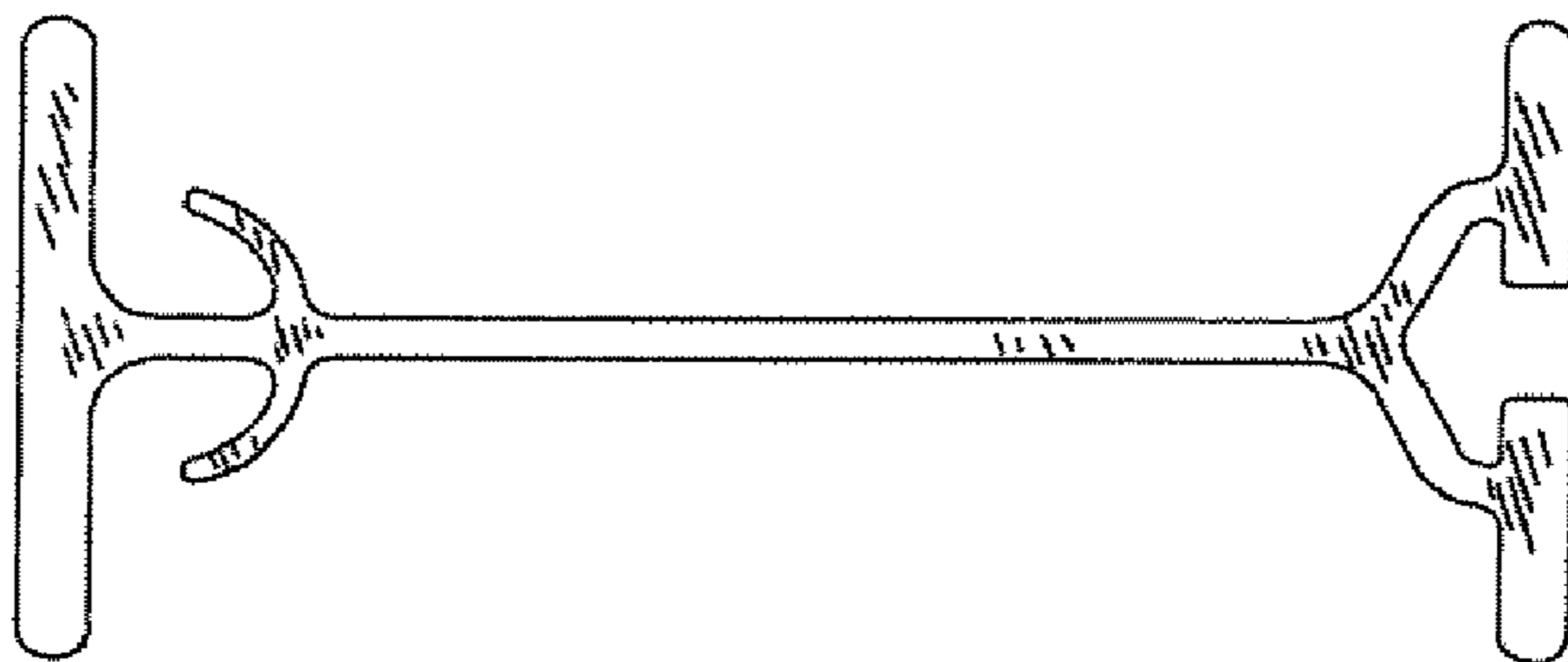

Fig. 2

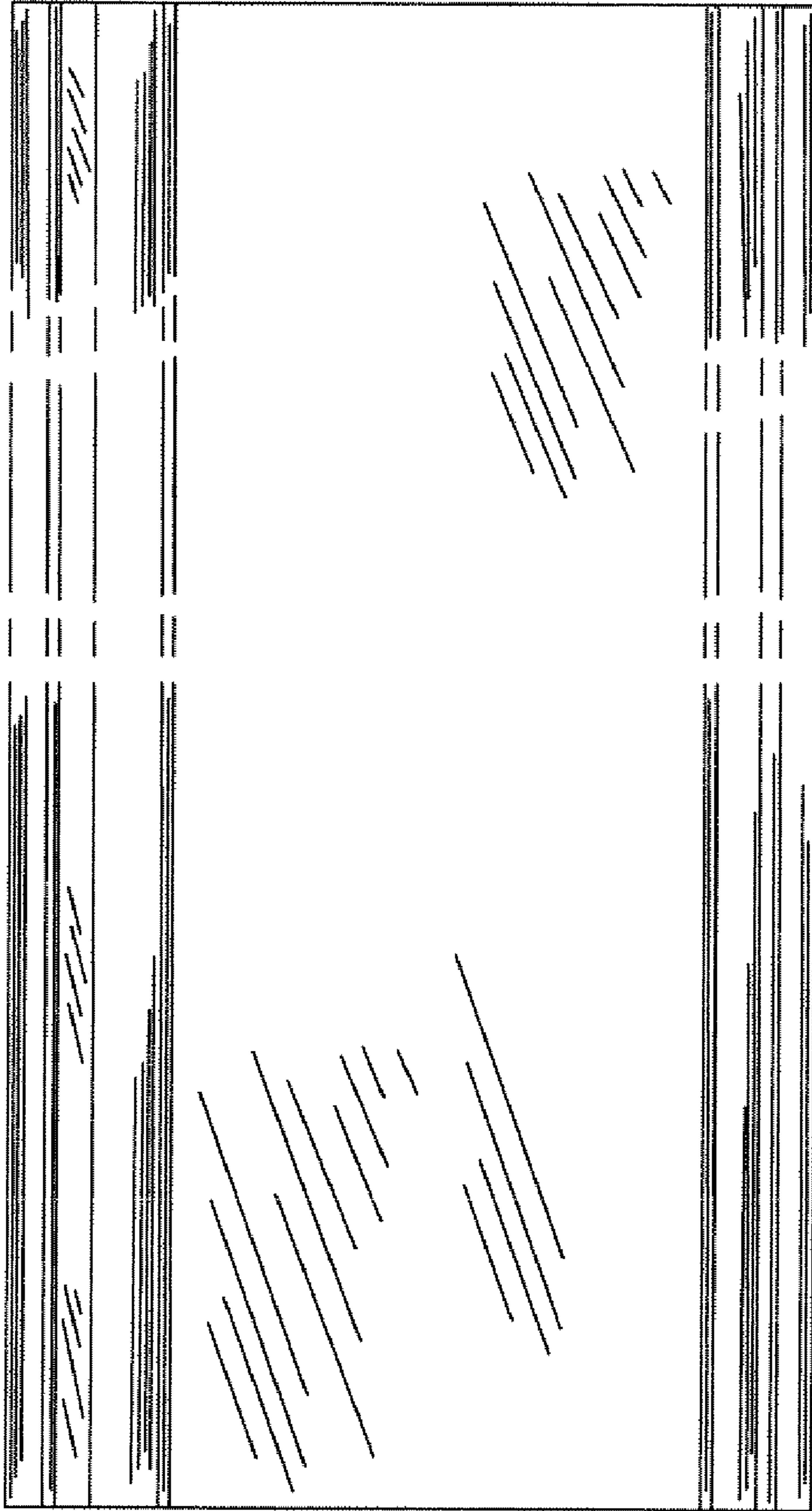

Fig. 3

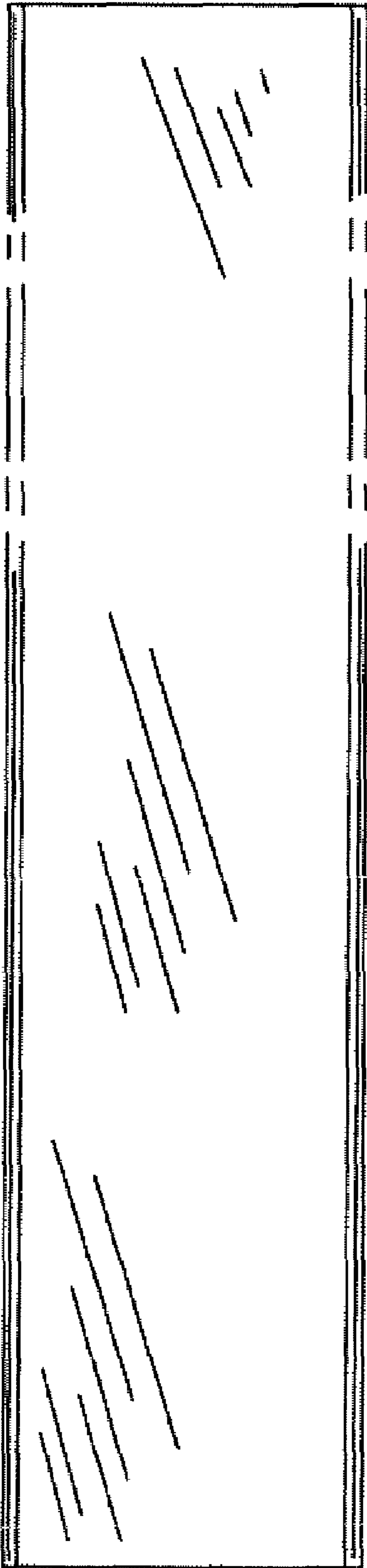

Fig. 4

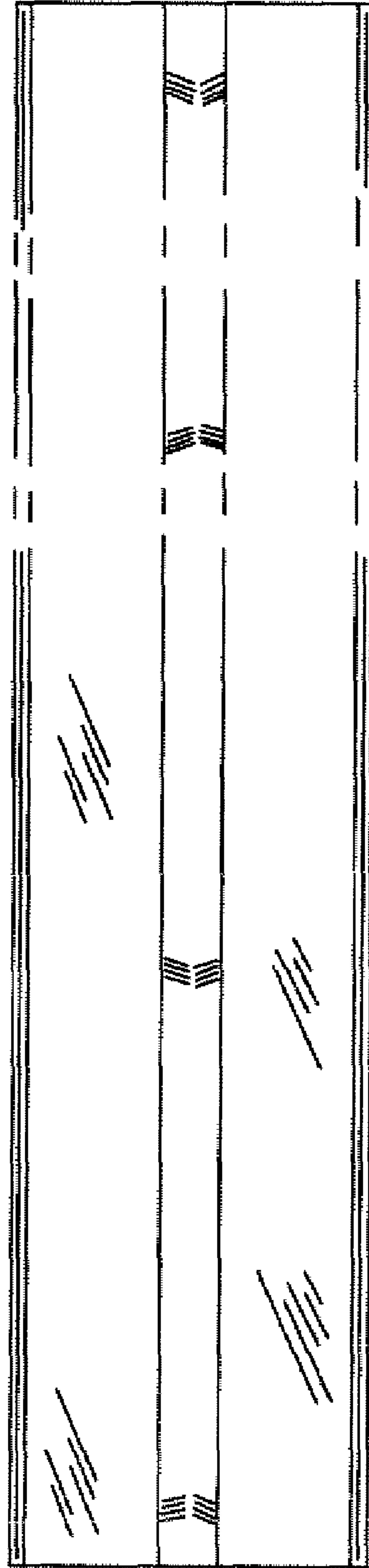

Fig. 5