



US00D56995S

(12) **United States Design Patent**
Downey et al.

(10) **Patent No.: US D569,995 S**
(45) **Date of Patent: ** May 27, 2008**

- (54) **ARCUATE MOVABLE SHUTTER FOR ARCHITECTURAL OPENINGS**
- (75) Inventors: **Joseph M. Downey**, Gilbert, CO (US);
Michael K. Hansen, Mesa, CO (US)
- (73) Assignee: **Hunter Douglas Inc.**, Upper Saddle River, NJ (US)
- (**) Term: **14 Years**
- (21) Appl. No.: **29/297,670**
- (22) Filed: **Nov. 15, 2007**

Related U.S. Application Data

- (62) Division of application No. 29/235,685, filed on Aug. 4, 2005, now Pat. No. Des. 560,820.
- (51) **LOC (8) Cl.** **25-02**
- (52) **U.S. Cl.** **D25/47**
- (58) **Field of Classification Search** D25/49,
D25/47; 52/473, 656.7, 783.12; 49/74.1,
49/80.1, 73.1; 160/104, 113, 84.07, 84.01
See application file for complete search history.

References Cited

U.S. PATENT DOCUMENTS

3,075,257 A 1/1963 Rosen

(Continued)

Primary Examiner—Doris Clark
(74) *Attorney, Agent, or Firm*—Dorsey & Whitney LLP

CLAIM

We claim the ornamental design for an arcuate movable shutter for architectural openings, as shown and described.

DESCRIPTION

FIG. 1 is an isometric of the arcuate movable shutter for architectural openings of the present invention showing movable vanes in a closed 0° position.

FIG. 2 is a front elevation of the arcuate movable shutter for architectural openings of FIG. 1.

FIG. 3 is a top plan view of the arcuate movable shutter for architectural openings of FIG. 1.

FIG. 4 is a right side view of the arcuate movable shutter for architectural openings of FIG. 1.

FIG. 5 is a bottom plan view of the arcuate movable shutter for architectural openings of FIG. 1.

FIG. 6 is an isometric of the arcuate movable shutter for architectural openings of FIG. 1 with the movable vanes in a 45° position.

FIG. 7 is a front elevation of the arcuate movable shutter for architectural openings as seen in FIG. 6.

FIG. 8 is a top plan view of the arcuate movable shutter for architectural openings as seen in FIG. 6.

FIG. 9 is a right side elevation of the arcuate movable shutter for architectural openings as seen in FIG. 6.

FIG. 10 is a bottom plan view of the arcuate movable shutter for architectural openings as seen in FIG. 6.

FIG. 11 is an isometric of the arcuate movable shutter for architectural openings of FIG. 1 with the movable vanes in a 90° or fully open position.

FIG. 12 is a front elevation of the arcuate movable shutter for architectural openings as seen in FIG. 11.

FIG. 13 is a top plan view of the arcuate movable shutter for architectural openings as seen in FIG. 11.

FIG. 14 is a right side elevation of the arcuate movable shutter for architectural openings as seen in FIG. 11.

FIG. 15 is a bottom plan view of the arcuate movable shutter for architectural openings as seen in FIG. 11.

FIG. 16 is an isometric looking at the front of a vane used in the arcuate movable shutter for architectural openings of FIG. 1.

FIG. 17 is an inverted isometric showing the reverse side of the vane of FIG. 16.

FIG. 18 is a front elevation of the vane as seen in FIG. 17.

FIG. 19 is a top plan view of the vane as shown in FIG. 18 with a dashed line representation of adjacent vanes when the vanes are in a closed 0° position as shown in FIG. 1; and,

FIG. 20 is a bottom elevation of the vane of FIG. 18.

1 Claim, 8 Drawing Sheets

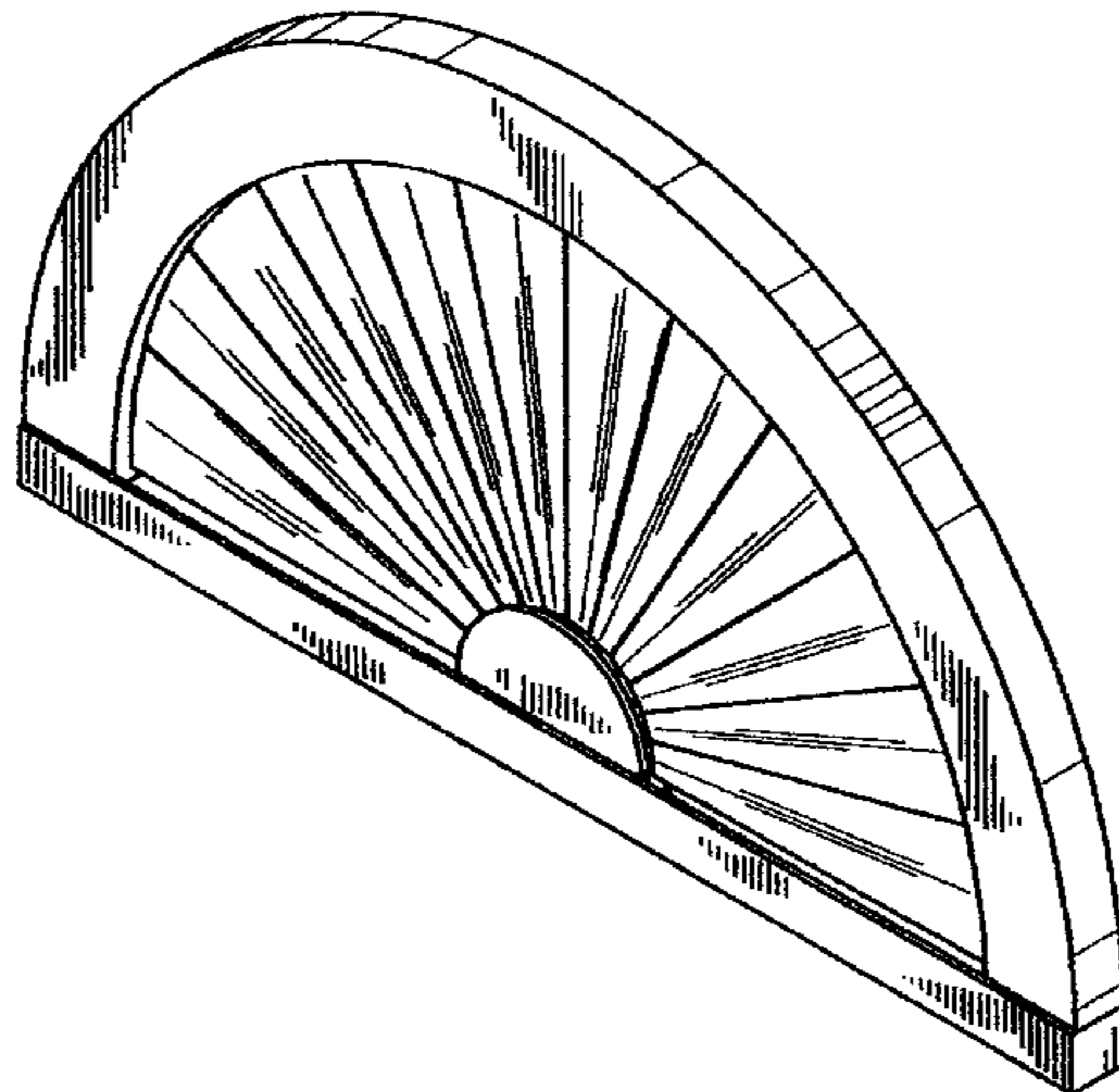

US D569,995 S

Page 2

U.S. PATENT DOCUMENTS

5,662,153	A *	9/1997	Rosenblatt	160/84.07	D432,663	S *	10/2000	Jean	D25/47
D389,690	S	1/1998	Denson		6,341,447	B1	1/2002	Jean	
5,782,051	A	7/1998	LaVoie		6,651,722	B1 *	11/2003	Fleishman et al.	160/168.1 V
5,823,241	A *	10/1998	Sitzes et al.	160/107	6,758,256	B1	7/2004	Garcia	
D402,374	S	12/1998	Kinder						

* cited by examiner

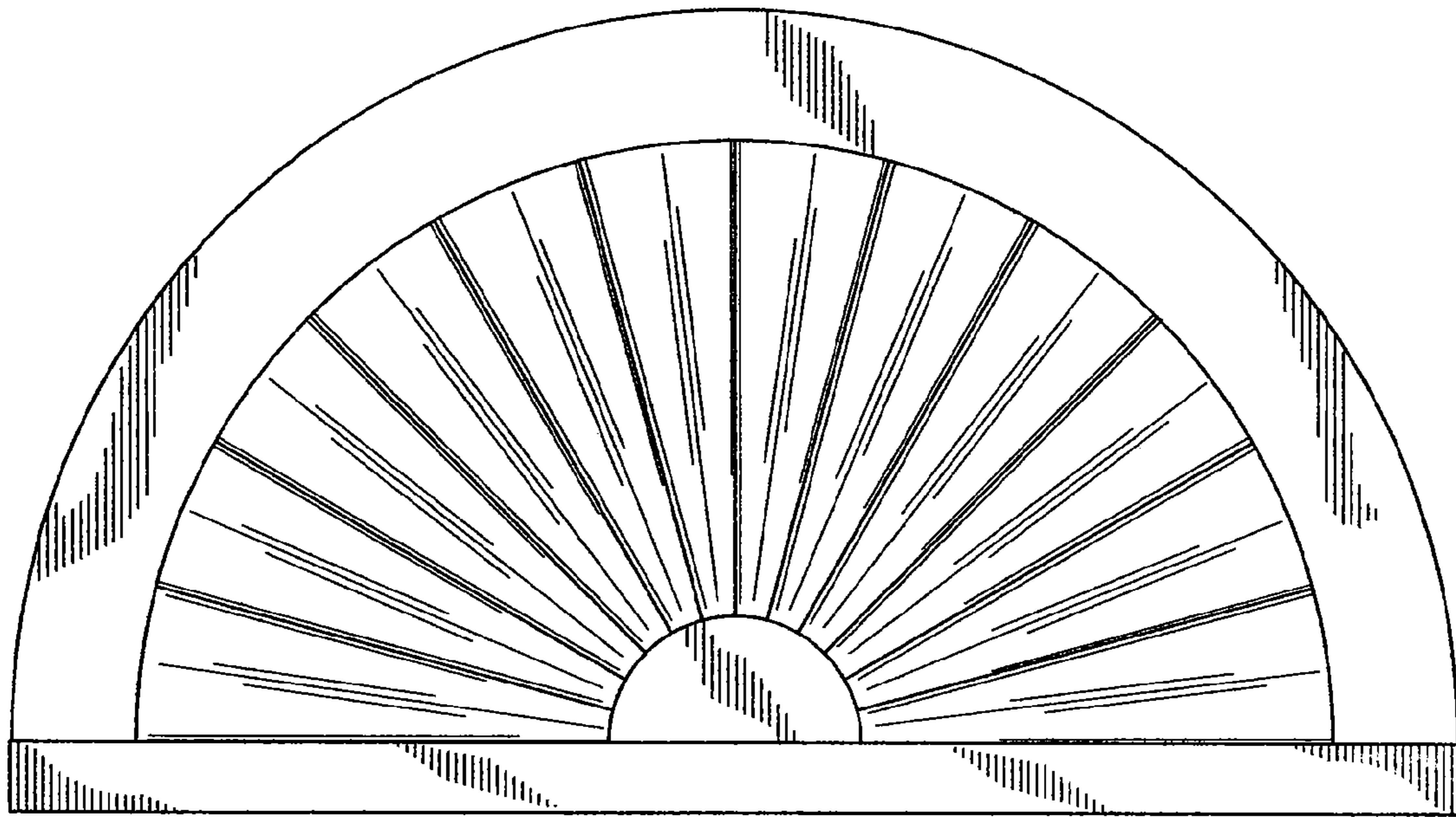

Fig. 2

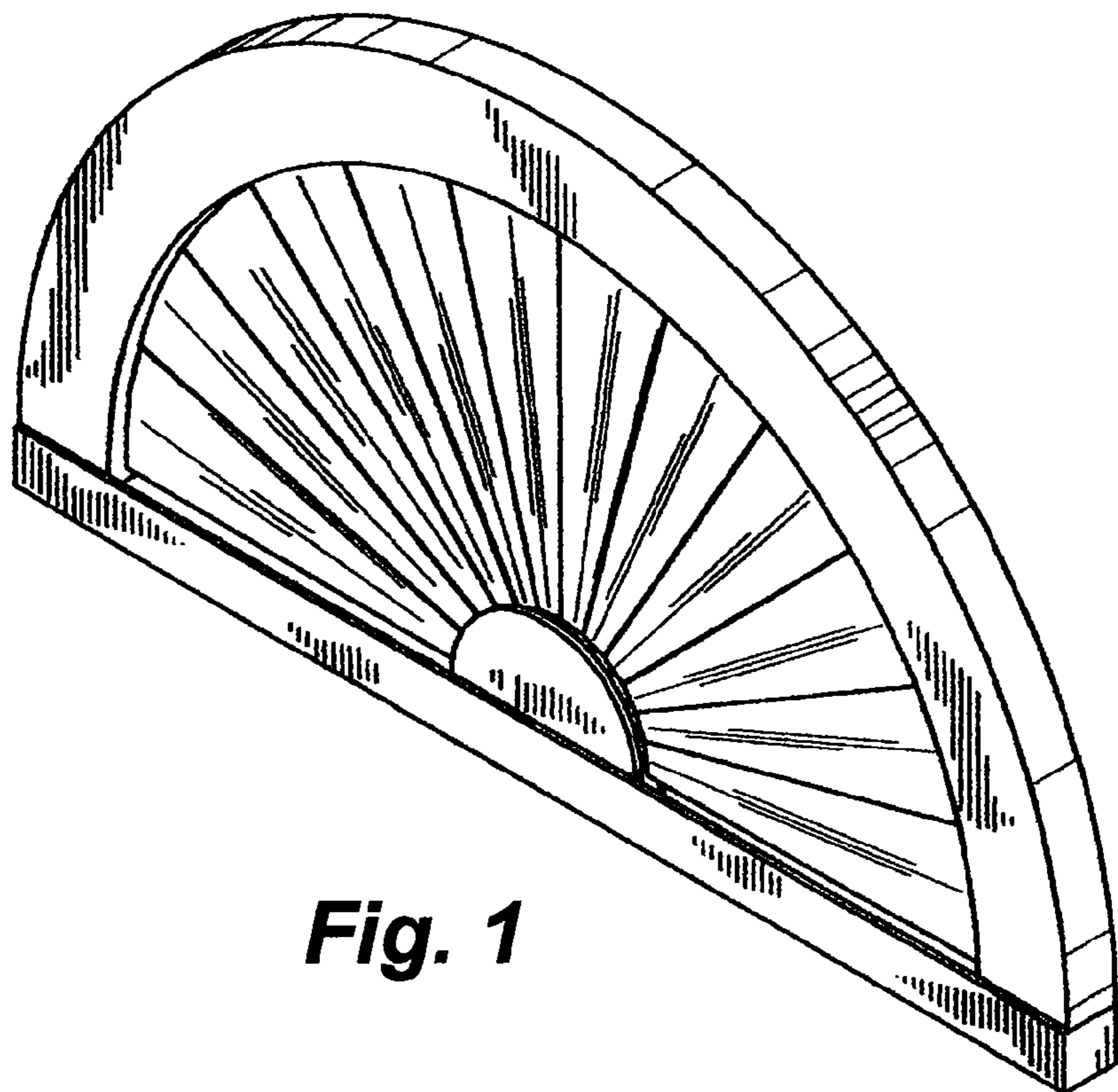

Fig. 1



Fig. 3

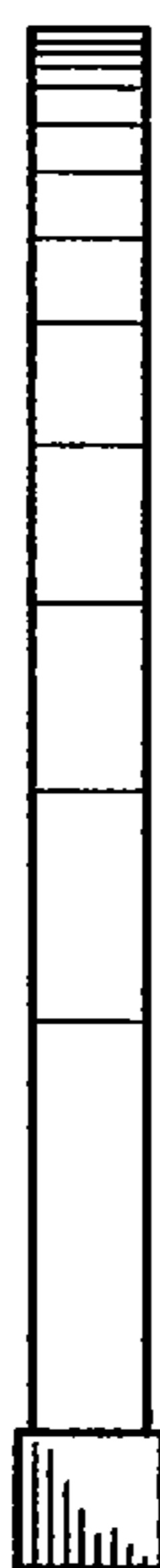

Fig. 4



Fig. 5

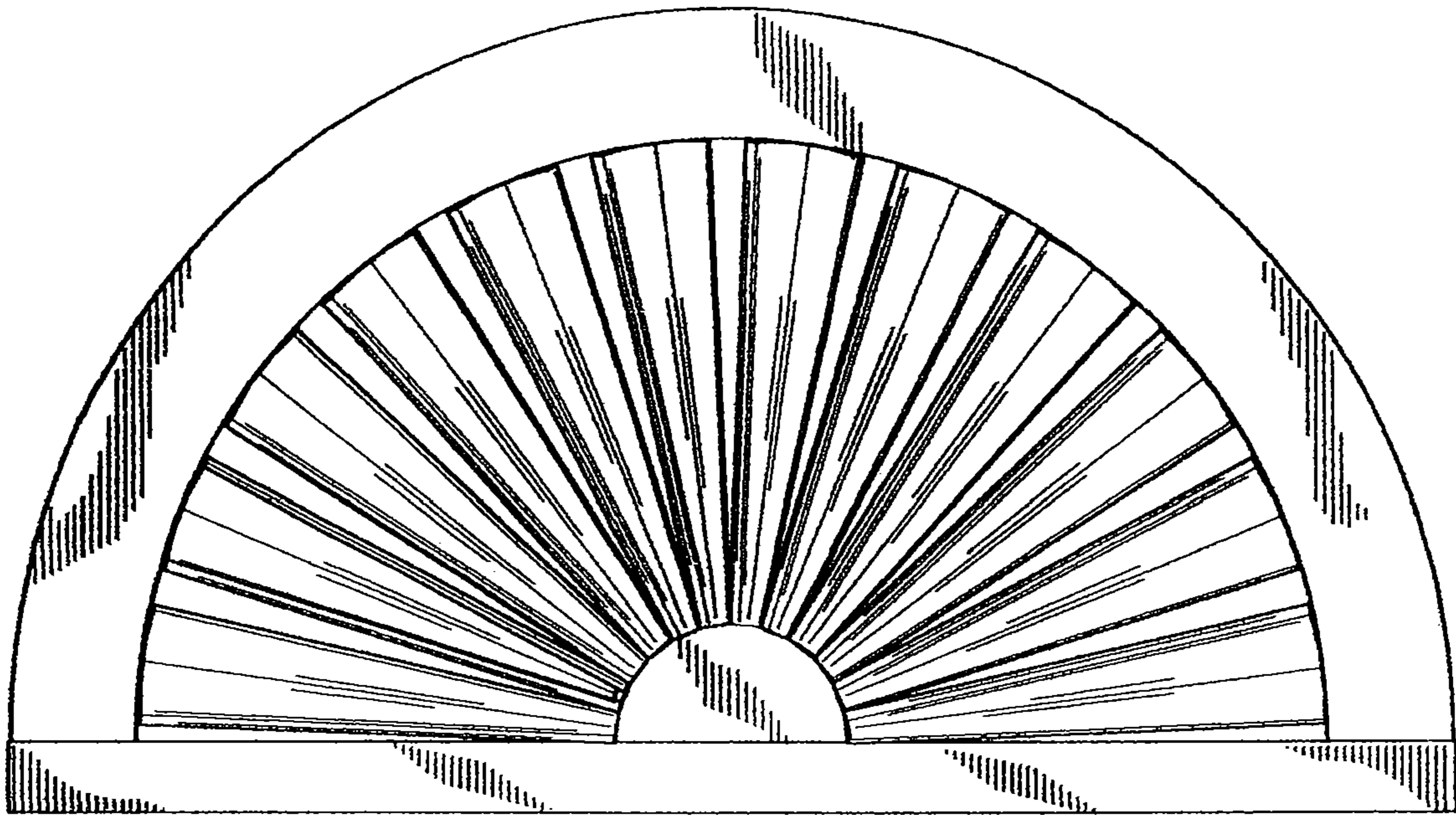

Fig. 7

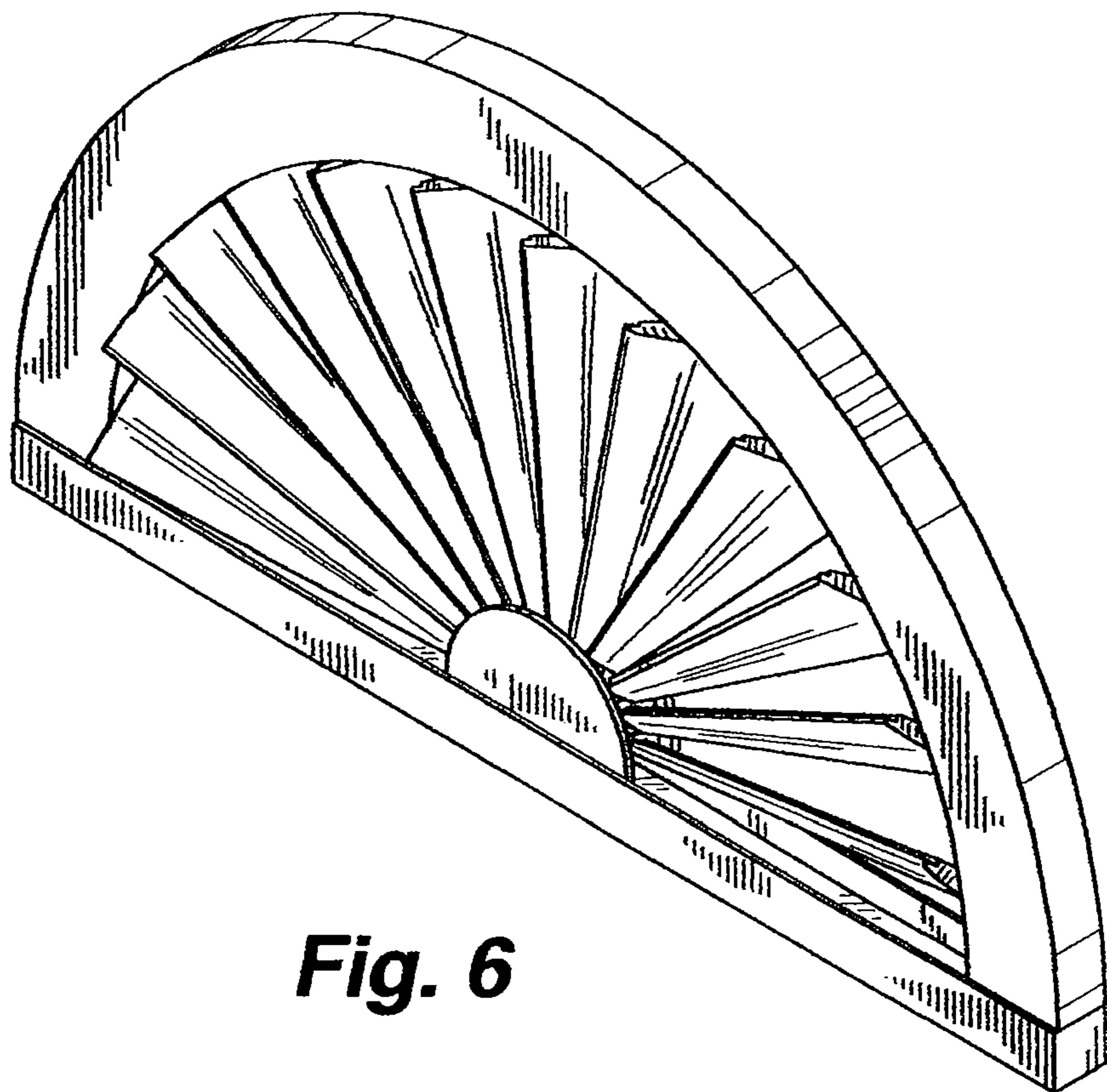

Fig. 6

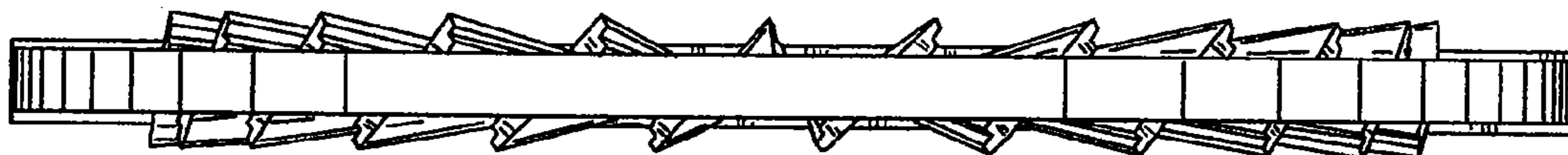

Fig. 8

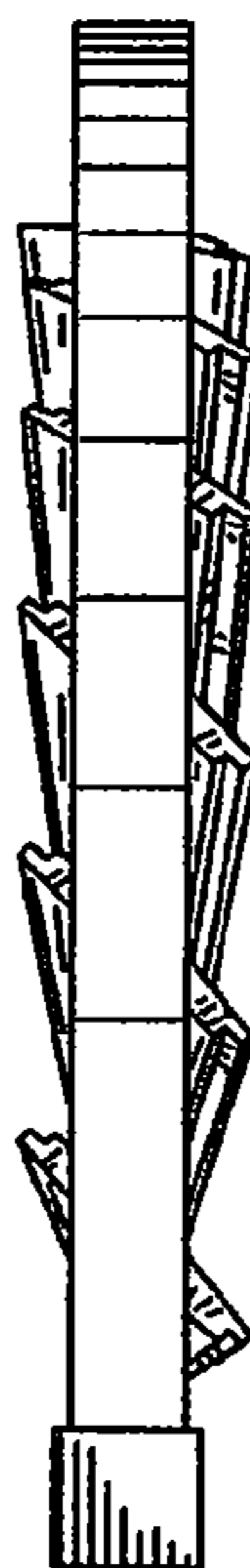

Fig. 9

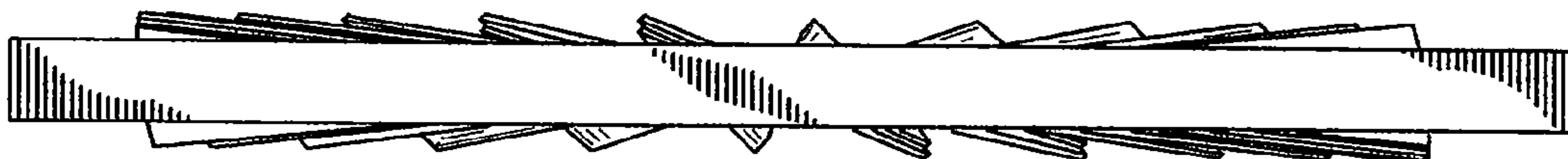

Fig. 10

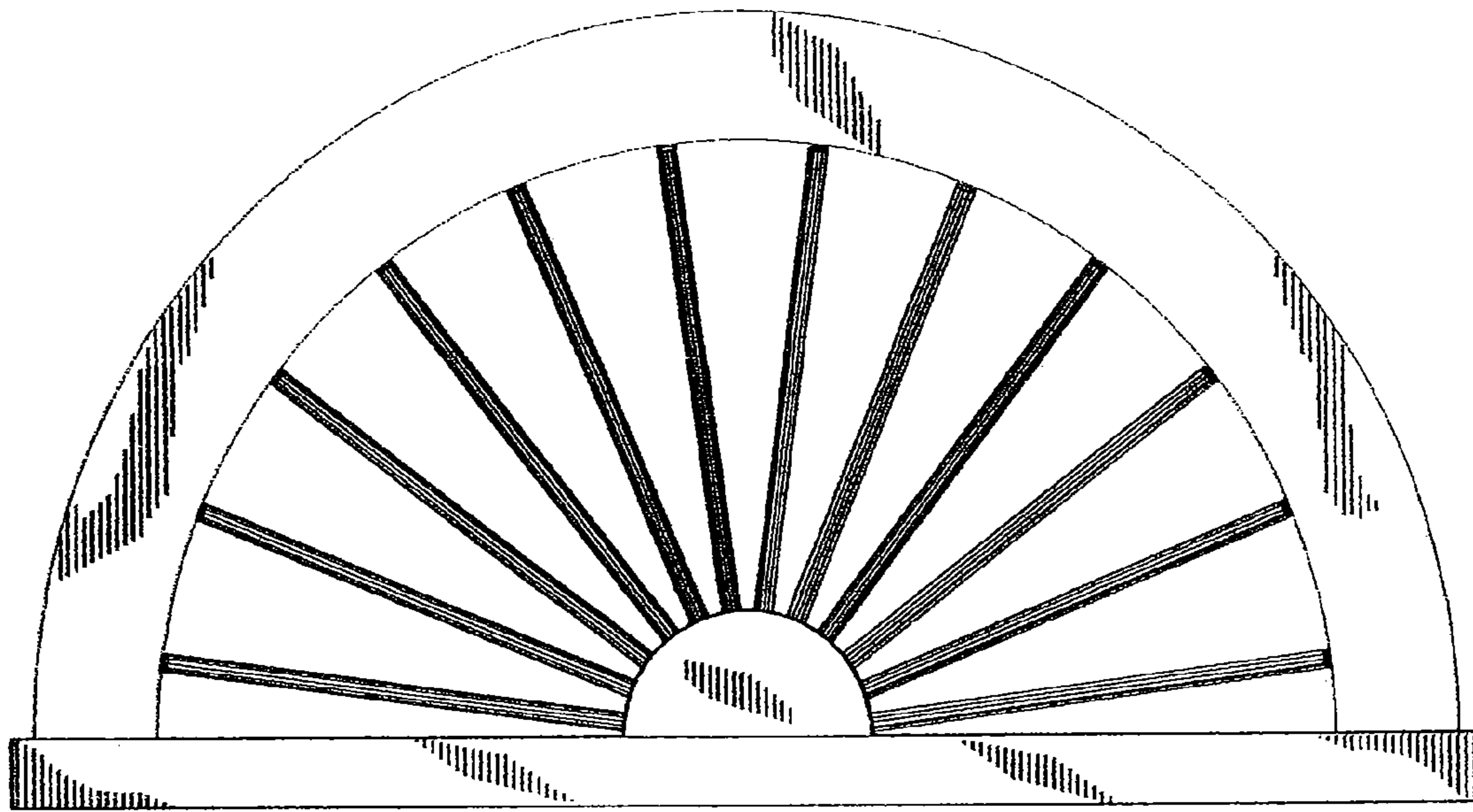

Fig. 12

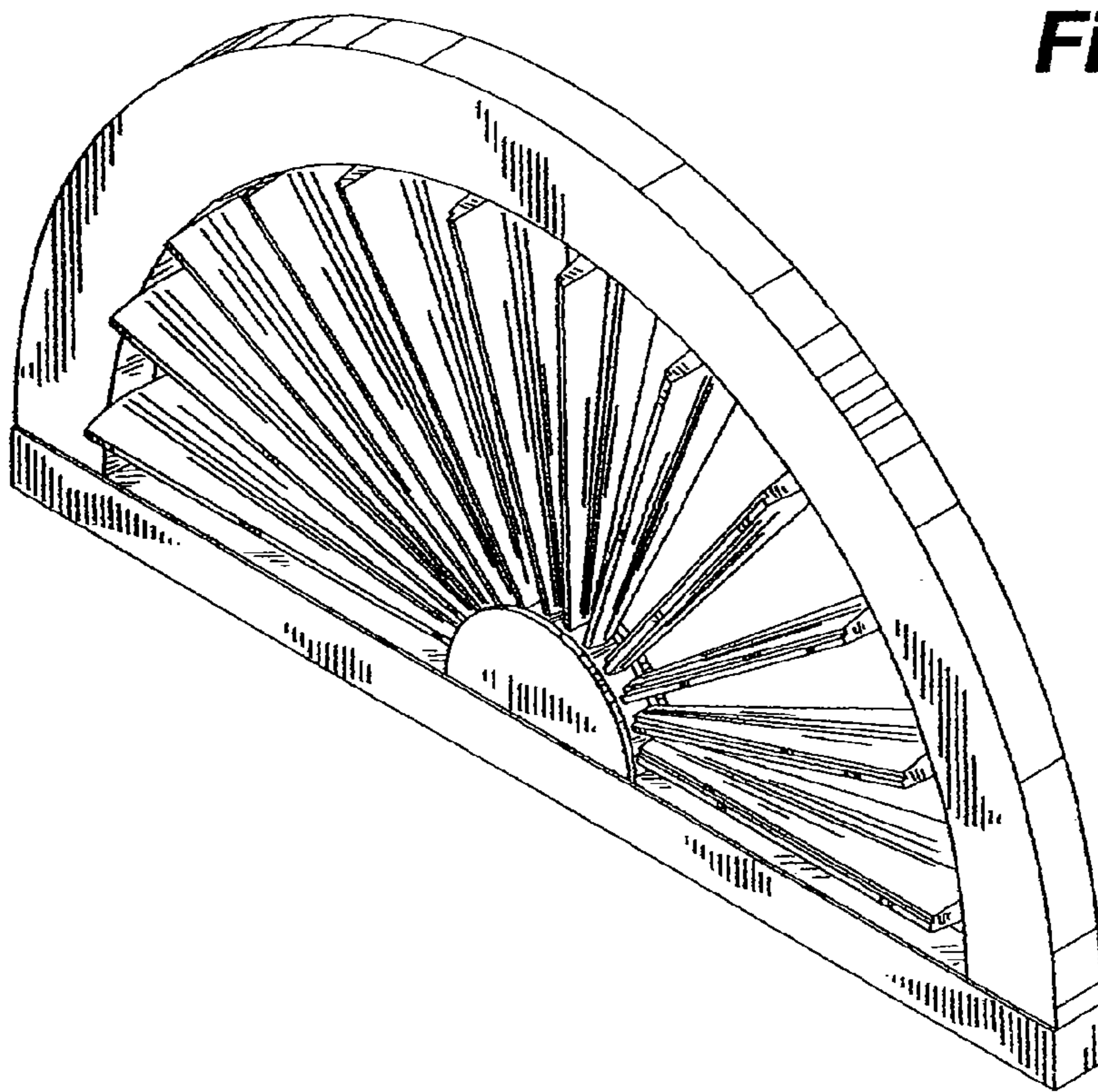

Fig. 11

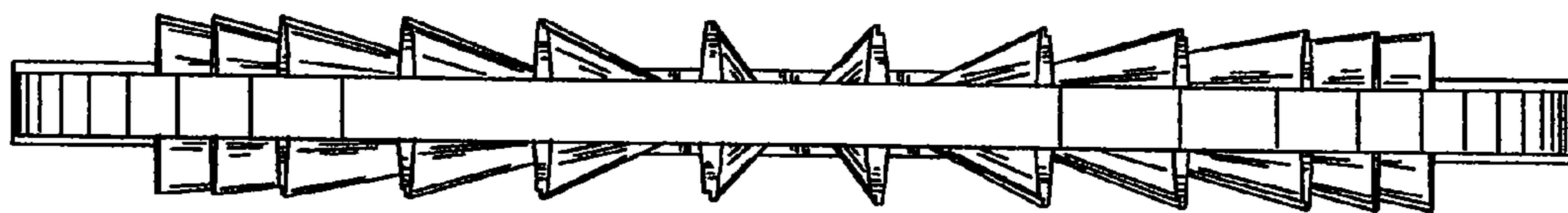

Fig. 13

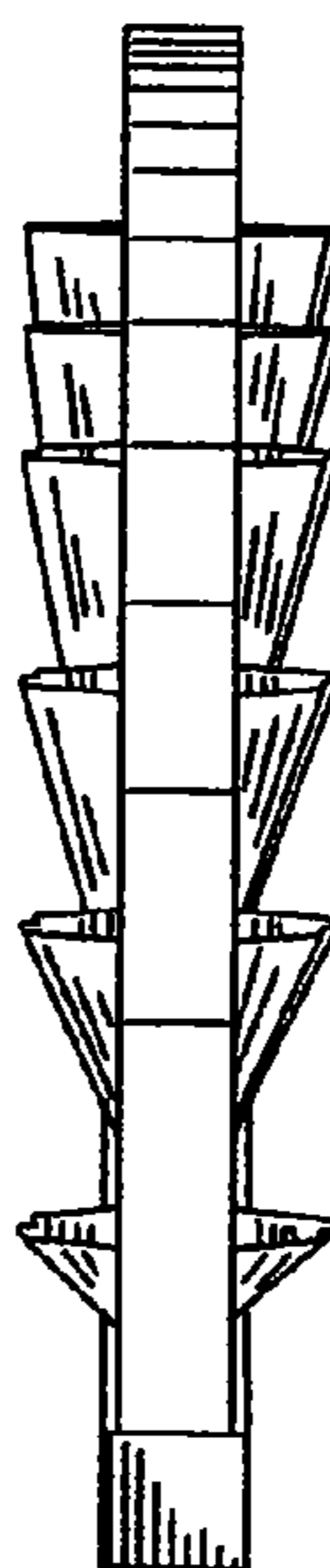

Fig. 14

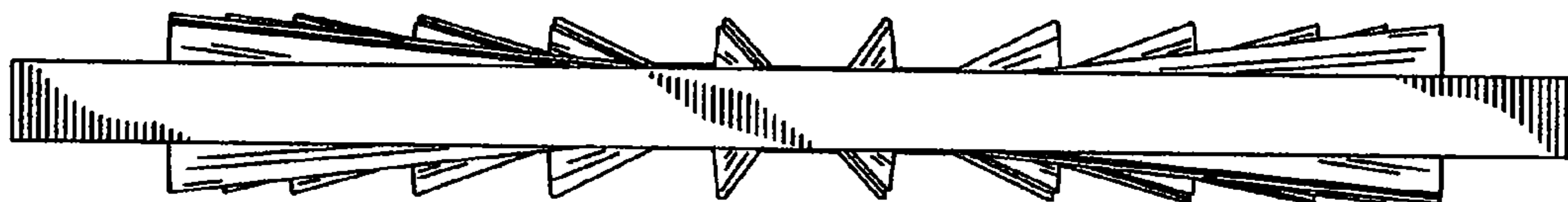

Fig. 15

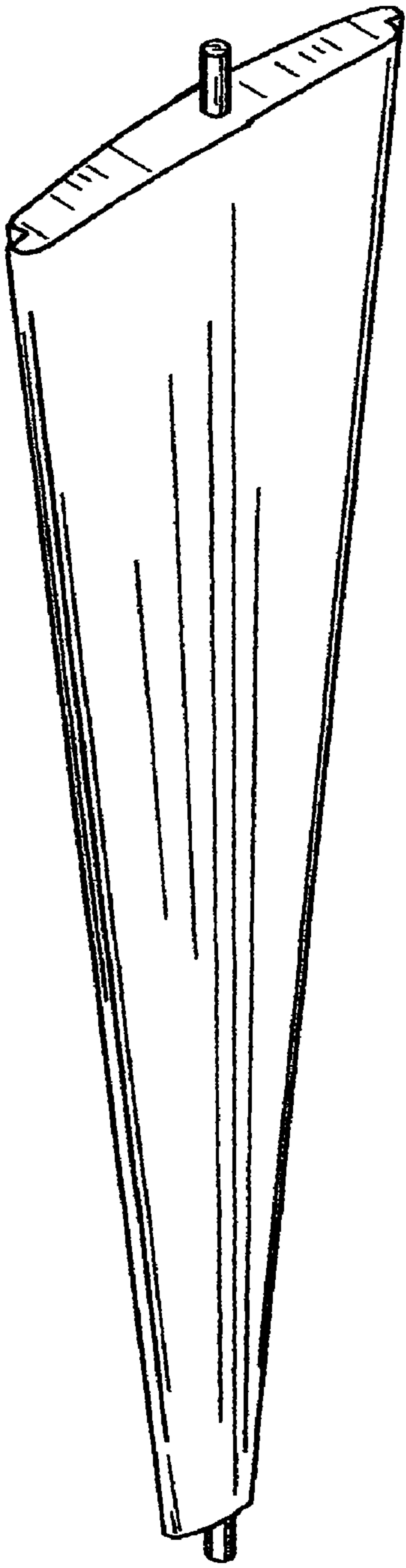

Fig. 16

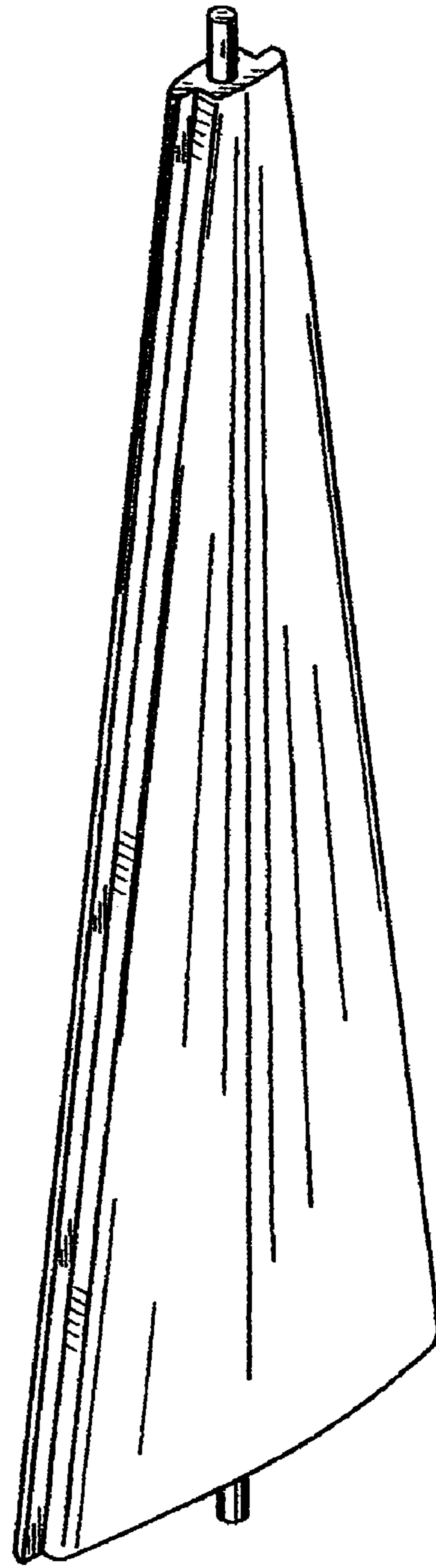

Fig. 17

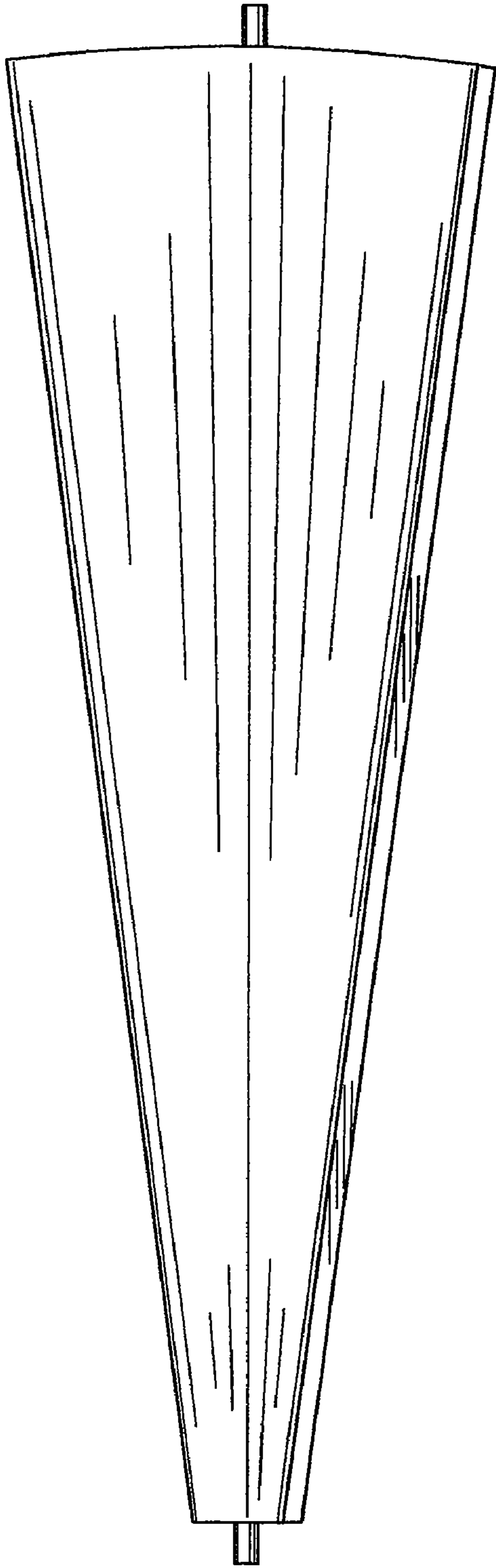

Fig. 18



Fig. 19



Fig. 20