

US00D569992S

(12) **United States Design Patent** (10) **Patent No.:** **US D569,992 S**  
**Christensen et al.** (45) **Date of Patent:** **\*\* May 27, 2008**

(54) **TRAFFIC BARRIER**  
(75) Inventors: **Marc E. Christensen**, Salt Lake City, UT (US); **David J. Lipniarski**, North Tonawanda, NY (US)

6,913,415 B1 \* 7/2005 Tagg ..... 404/6  
D519,646 S 4/2006 Wilmotte  
D533,281 S 12/2006 Christensen et al.  
2002/0025221 A1 2/2002 Johnson  
2003/0219308 A1 11/2003 Boulais et al.  
2004/0057790 A1 3/2004 Tagg

(73) Assignee: **Off the Wall Products, LLC**, Salt Lake City, UT (US)

**FOREIGN PATENT DOCUMENTS**

(\*\*) Term: **14 Years**

AU B-50241/93 8/1994  
EP 0 550 362 A1 7/1993

(21) Appl. No.: **29/275,783**  
(22) Filed: **Jan. 5, 2007**

**OTHER PUBLICATIONS**

Multi-Barrier, Model AR-10x96 Specification, Jan. 2003.

(51) **LOC (8) Cl.** ..... **25-02**  
(52) **U.S. Cl.** ..... **D25/38**  
(58) **Field of Classification Search** ..... D25/38;  
404/6, 8; 256/13.1  
See application file for complete search history.

\* cited by examiner

*Primary Examiner*—Doris Clark  
(74) *Attorney, Agent, or Firm*—Workman Nydegger

(56) **References Cited**

(57) **CLAIM**

The ornamental design for a traffic barrier, as shown and described.

**U.S. PATENT DOCUMENTS**

**DESCRIPTION**

4,040,759 A 8/1977 Skalle  
4,143,857 A 3/1979 Weiner  
4,614,181 A 9/1986 Karlsson  
4,681,302 A 7/1987 Thompson  
4,854,767 A 8/1989 Sasaki  
5,011,325 A 4/1991 Antoniol  
5,022,781 A 6/1991 Smith  
5,123,773 A 6/1992 Yodock  
5,197,601 A 3/1993 Sterett  
5,259,154 A 11/1993 Lilley  
5,387,049 A 2/1995 Duckett  
D363,789 S \* 10/1995 Weid ..... D25/38  
5,498,101 A 3/1996 Braverman  
5,611,641 A 3/1997 Christensen  
5,639,179 A 6/1997 Jensen  
D385,362 S \* 10/1997 Rossetti ..... D25/58  
D400,264 S 10/1998 Striefel et al.  
5,836,714 A 11/1998 Christensen  
5,988,934 A 11/1999 Wasserstrom  
6,059,487 A 5/2000 Haga et al.  
6,059,491 A \* 5/2000 Striefel et al. .... 405/111  
6,086,285 A 7/2000 Christensen  
D462,126 S 8/2002 Englund  
6,837,647 B2 \* 1/2005 Tagg ..... 404/6

FIG. 1 is a perspective view of a traffic barrier showing our new design;  
FIG. 2 is an elevated front view thereof, the elevated rear view thereof being the mirror image thereof;  
FIG. 3 is a top plan view thereof;  
FIG. 4 is a bottom plan view thereof;  
FIG. 5 is an elevated left side view thereof;  
FIG. 6 is an elevated right side view thereof;  
FIG. 7 is a perspective view of a second embodiment of the traffic barrier shown in FIG. 1;  
FIG. 8 is an elevated front view thereof, the elevated back view thereof being the mirror image thereof;  
FIG. 9 is a top plan view thereof;  
FIG. 10 is a bottom plan view thereof;  
FIG. 11 is an elevated left side view thereof; and,  
FIG. 12 is an elevated right side view thereof.

**1 Claim, 4 Drawing Sheets**

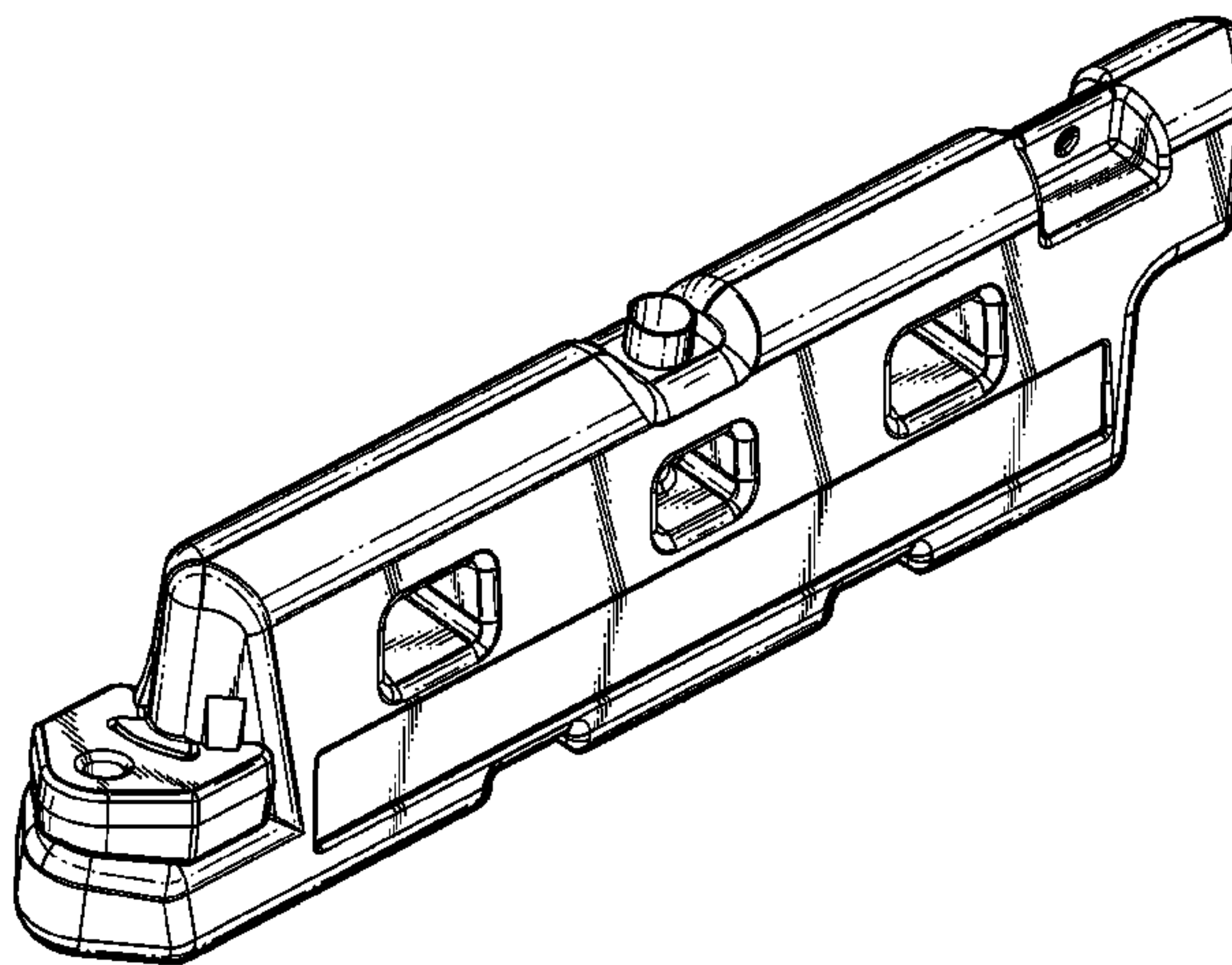

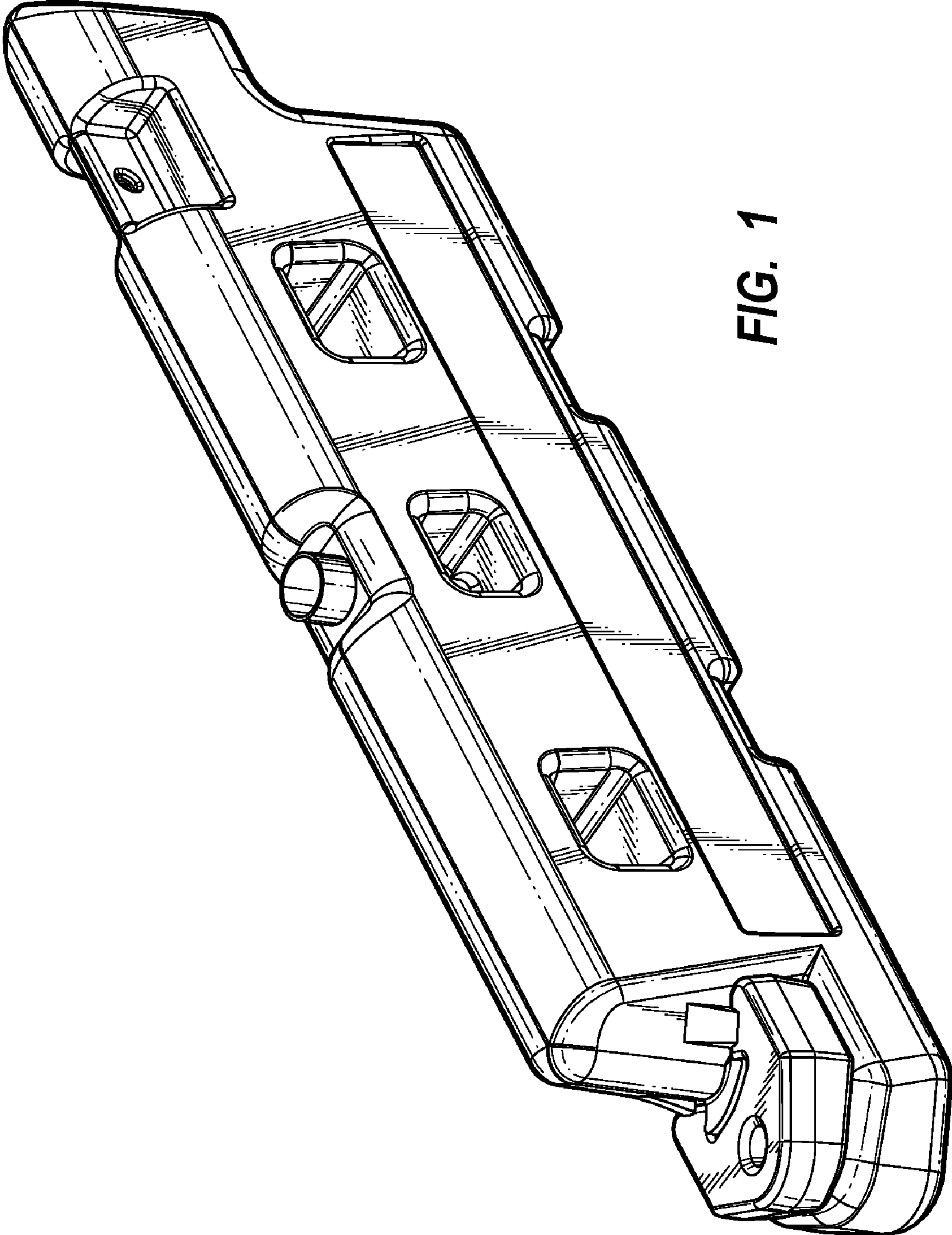

FIG. 1

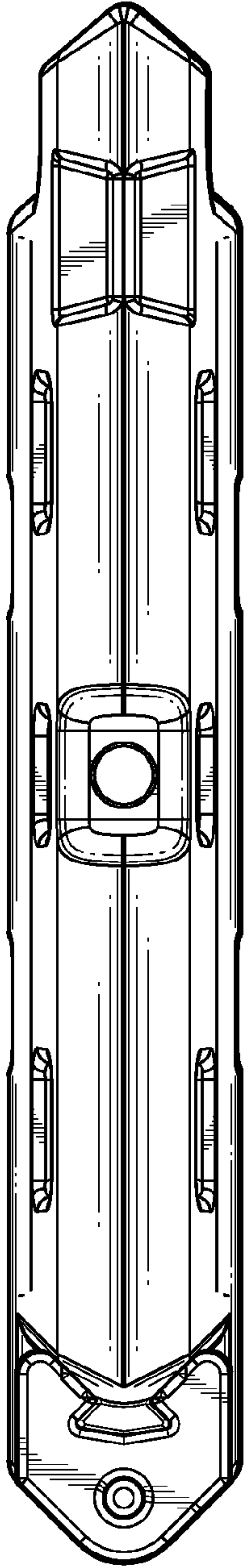

FIG. 3

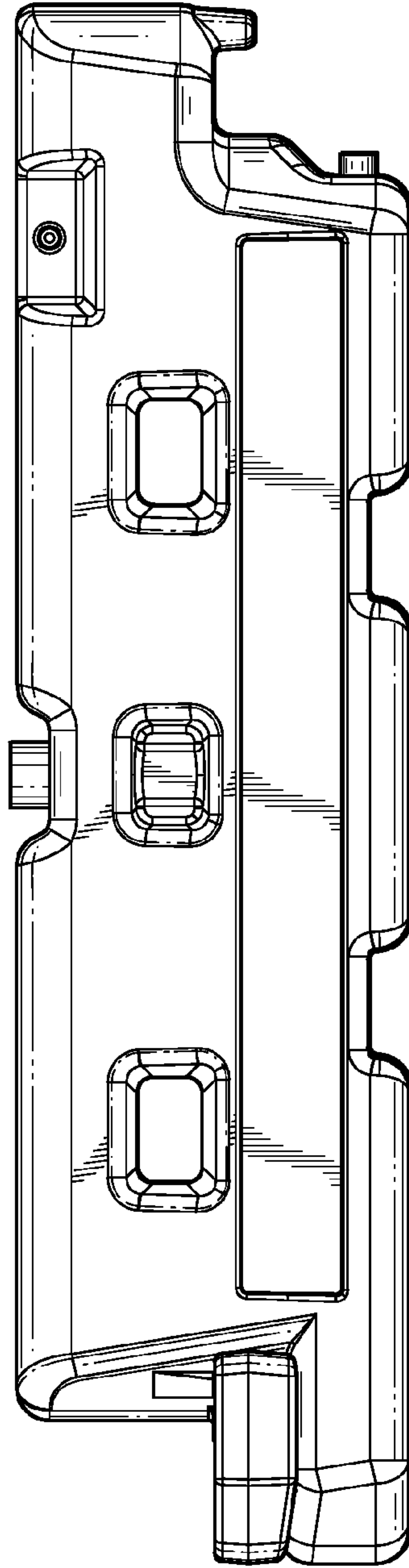

FIG. 2

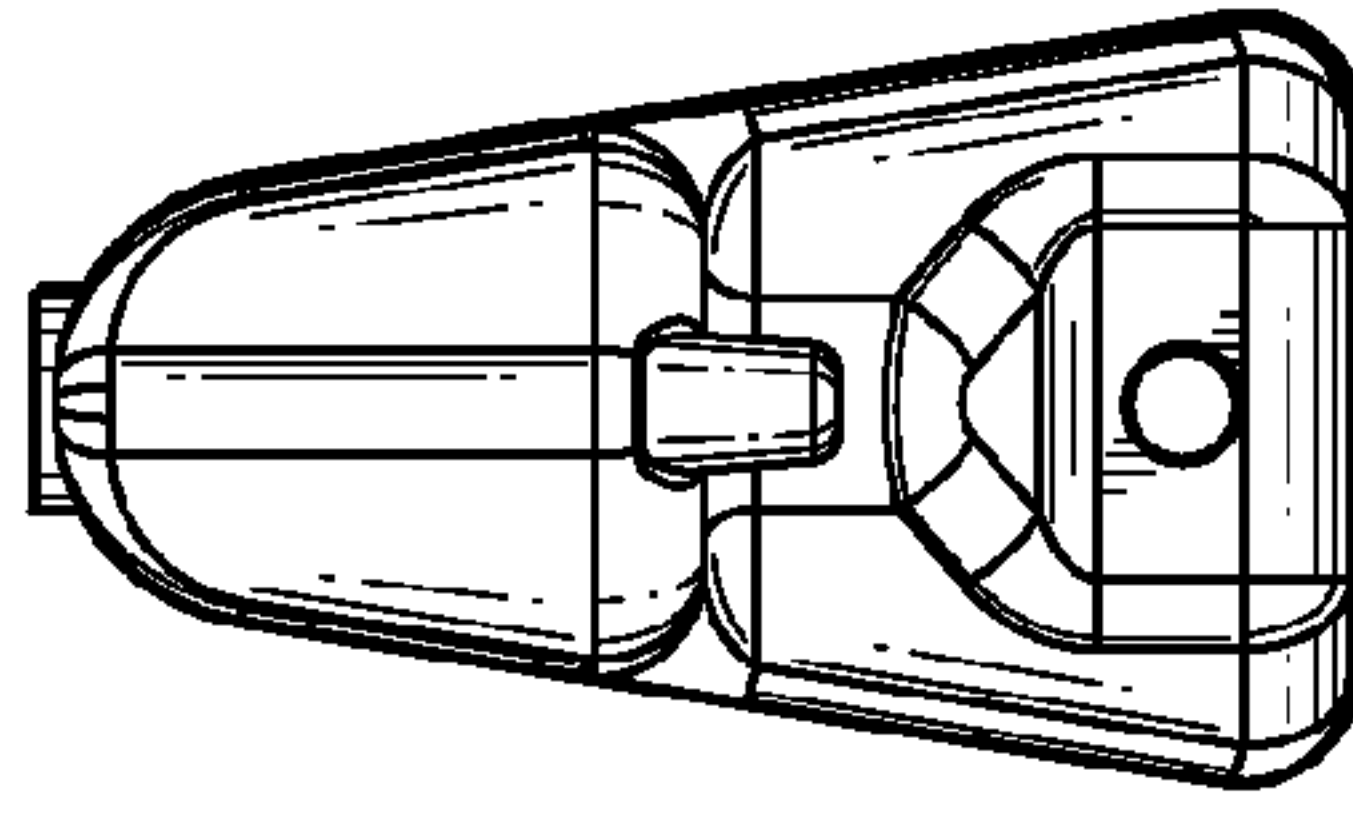

FIG. 6

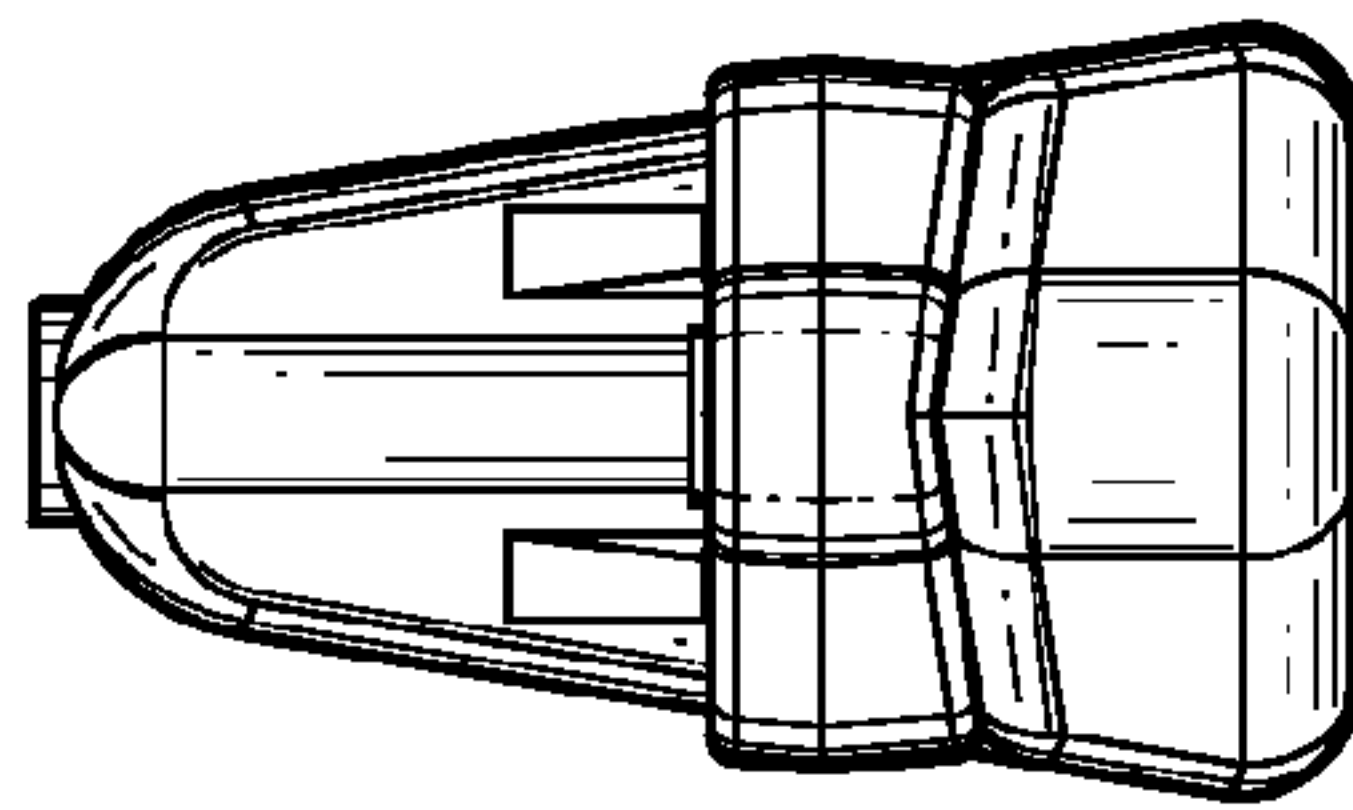

FIG. 5

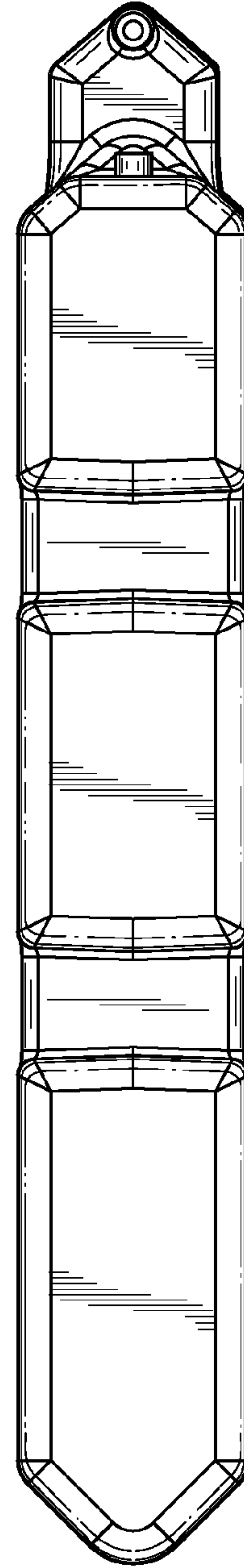

FIG. 4



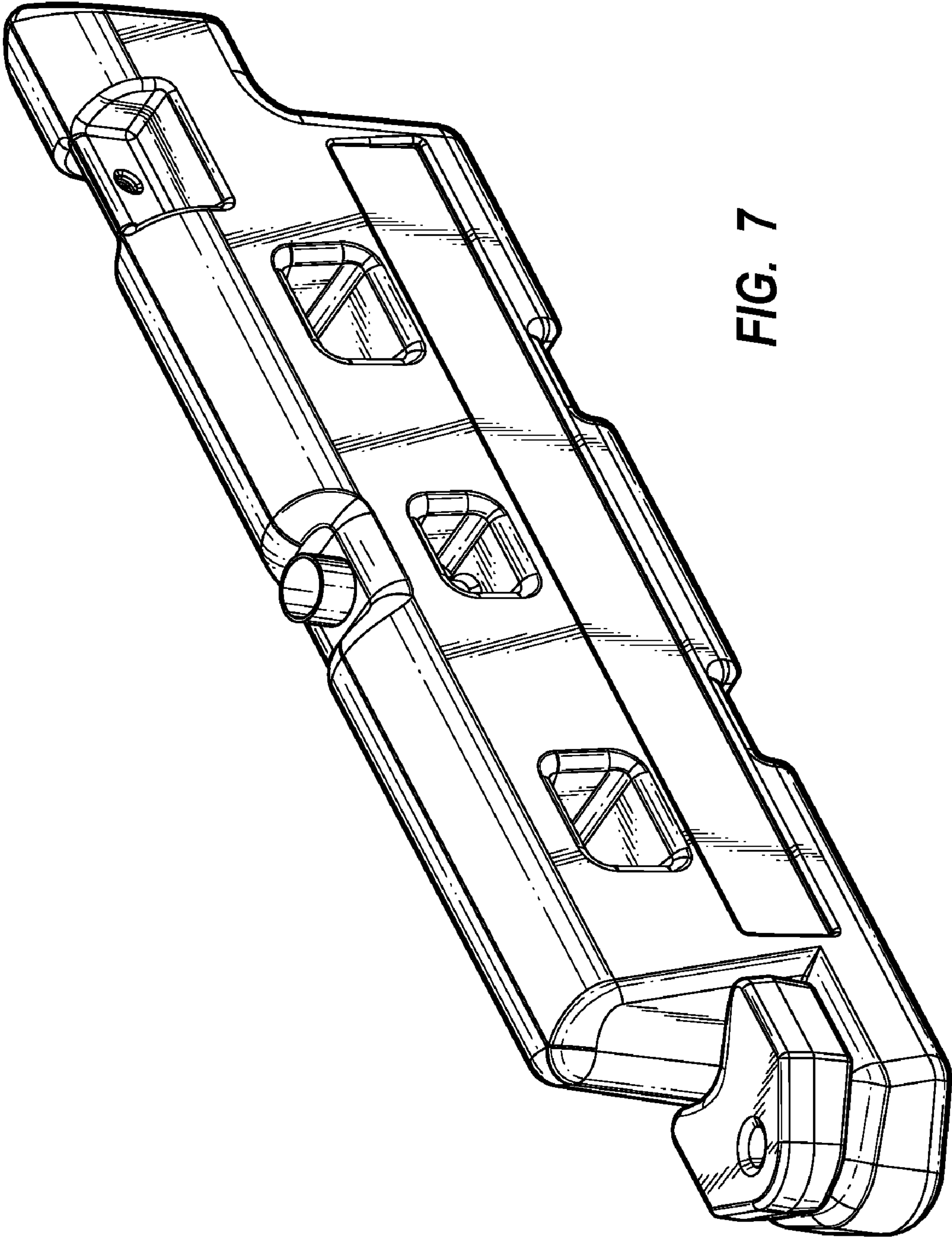

FIG. 7

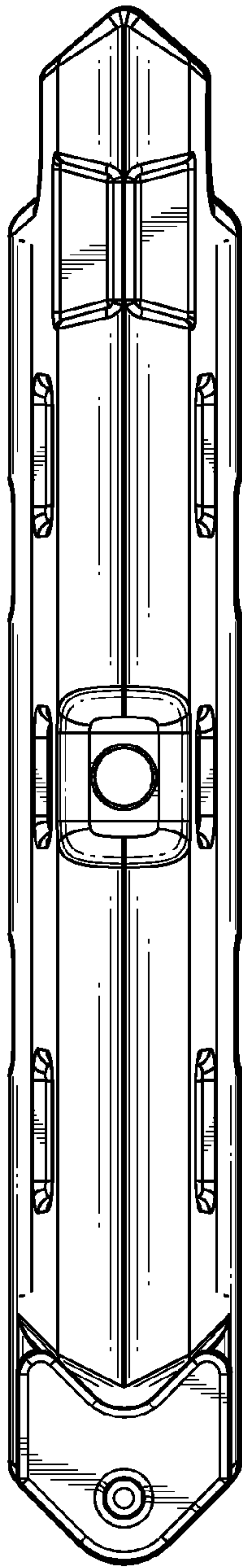

FIG. 9

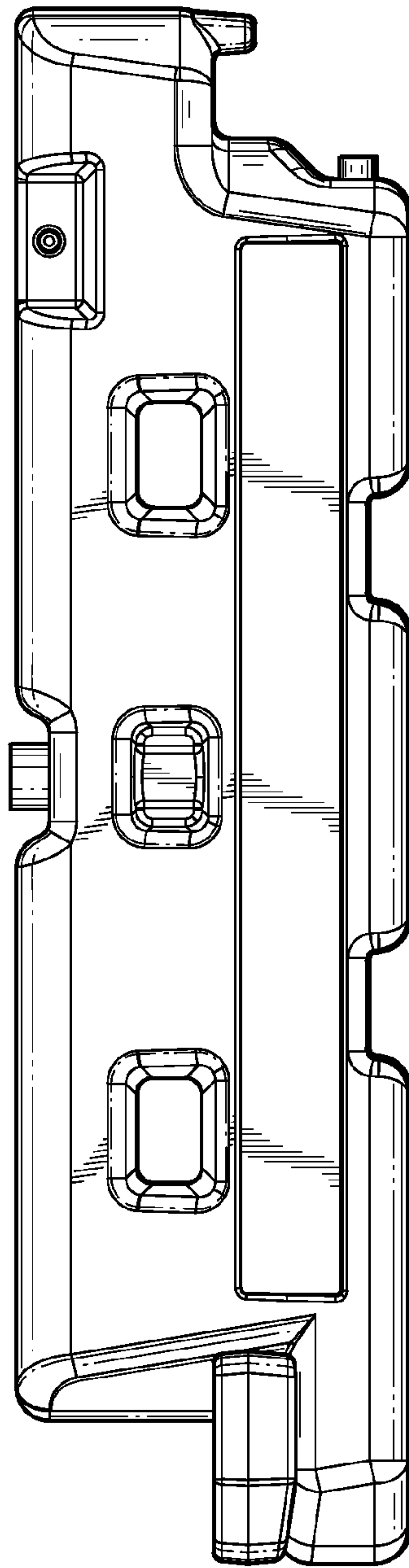

FIG. 8

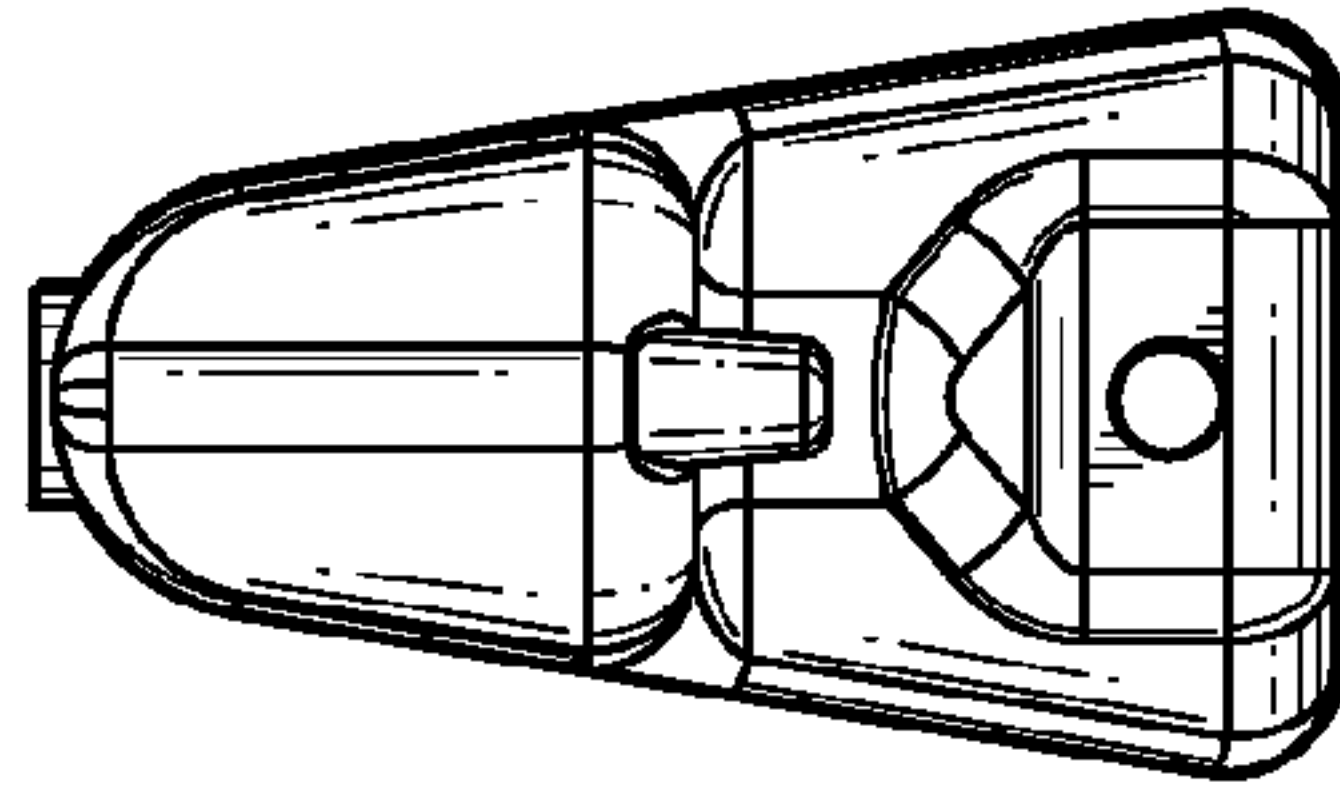

FIG. 12

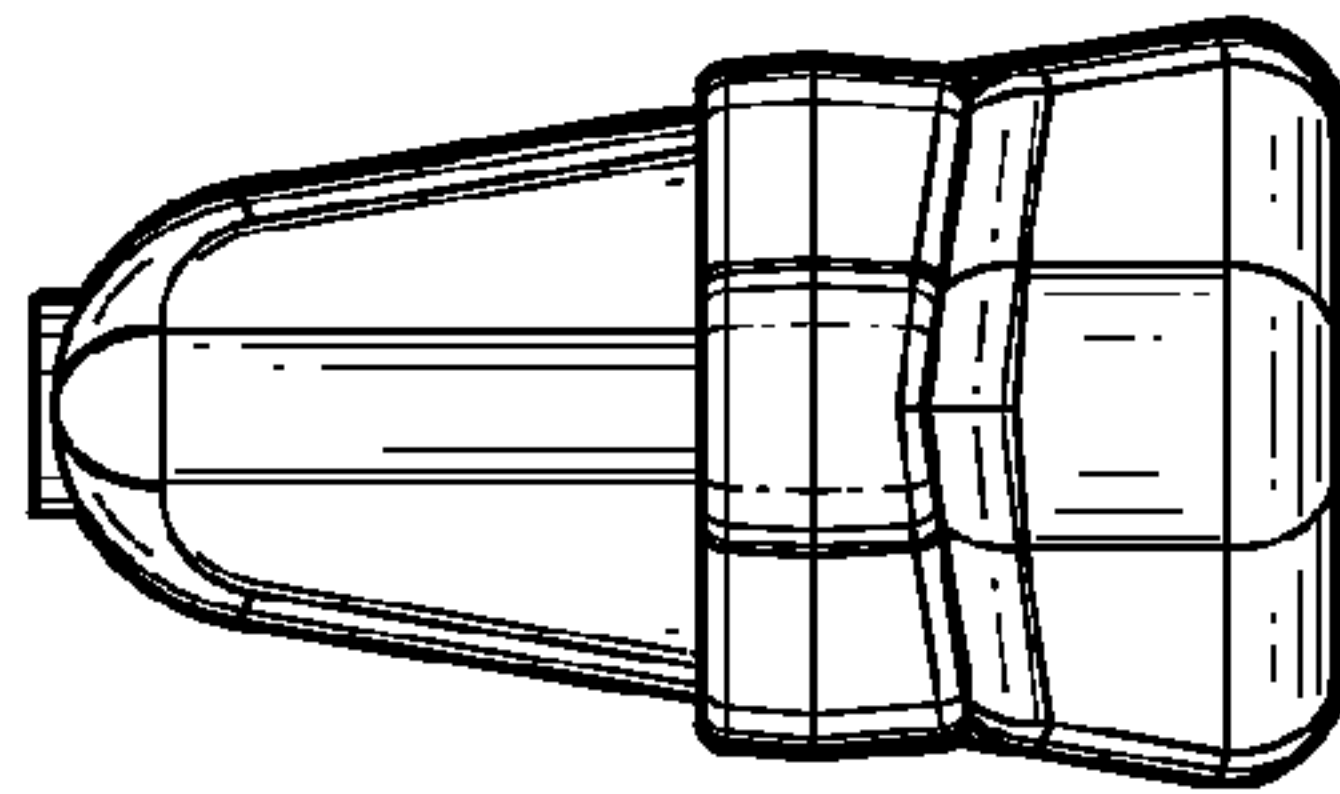

FIG. 11

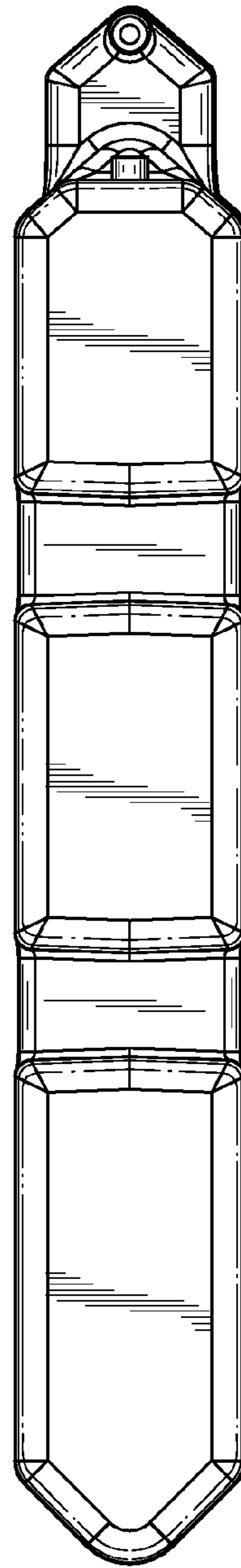

FIG. 10