



US00D569737S

(12) **United States Design Patent**
Ogawa et al.

(10) **Patent No.:** **US D569,737 S**

(45) **Date of Patent:** **** May 27, 2008**

(54) **ANTISEPTIC SOLUTION BOTTLE**

(75) Inventors: **Akio Ogawa**, Tokyo (JP); **Takayoshi Iwanami**, Hachioji (JP)

(73) Assignee: **Olympus Medical System Corp.**, Tokyo (JP)

(**) Term: **14 Years**

(21) Appl. No.: **29/250,976**

(22) Filed: **Dec. 7, 2006**

(51) **LOC (8) Cl.** **09-01**

(52) **U.S. Cl.** **D9/740; D9/741; D9/738**

(58) **Field of Classification Search** D9/434,
D9/435, 516, 517, 528, 529, 532, 562, 563,
D9/572, 575, 684, 686, 687, 694, 737, 738,
D9/740, 741, 743; D24/121, 122; 215/6,
215/10, 396, 398, 381-385

See application file for complete search history.

(56) **References Cited**

U.S. PATENT DOCUMENTS

- 1,459,257 A * 6/1923 Reger 220/524
- 2,641,374 A * 6/1953 Der Yuen 215/10
- 3,194,426 A * 7/1965 Brown, Jr. 220/23.4
- D244,992 S * 7/1977 Van der Veken D9/640
- 4,196,808 A * 4/1980 Pardo 206/432
- D263,118 S * 2/1982 Weckman D9/741
- 4,713,064 A * 12/1987 Bruno et al. 604/257
- 4,881,652 A * 11/1989 Schiemann 220/23.8
- D319,970 S * 9/1991 Beeman D9/741

- D327,639 S * 7/1992 Burns D9/740
- 5,316,159 A * 5/1994 Douglas et al. 215/10
- D373,606 S * 9/1996 Knudsen D21/503
- D374,481 S * 10/1996 McCallister et al. D24/121
- D382,061 S * 8/1997 Mathis et al. D24/224
- 5,692,626 A * 12/1997 Wehrle et al. 215/6
- D388,698 S * 1/1998 Newsom D9/742
- D439,156 S * 3/2001 Hall et al. D9/743
- D475,296 S * 6/2003 Lee D9/739
- 6,588,612 B1 * 7/2003 Dorn et al. 215/10
- D543,867 S * 6/2007 Yourist D9/739

* cited by examiner

Primary Examiner—Stella M. Reid

Assistant Examiner—Elizabeth J Oswecki

(74) *Attorney, Agent, or Firm*—Hogan & Hartson LLP

(57) **CLAIM**

The ornamental design for an antiseptic solution bottle, as shown and described.

DESCRIPTION

FIG. 1 is a perspective view of an antiseptic solution bottle, showing our new design;

FIG. 2 is a front elevation view thereof, the rear elevation view being a mirror image thereof;

FIG. 3 is a right side elevation view thereof, the left side elevation view being a mirror image thereof;

FIG. 4 is a top plan view thereof; and,

FIG. 5 is a bottom plan view thereof.

1 Claim, 4 Drawing Sheets

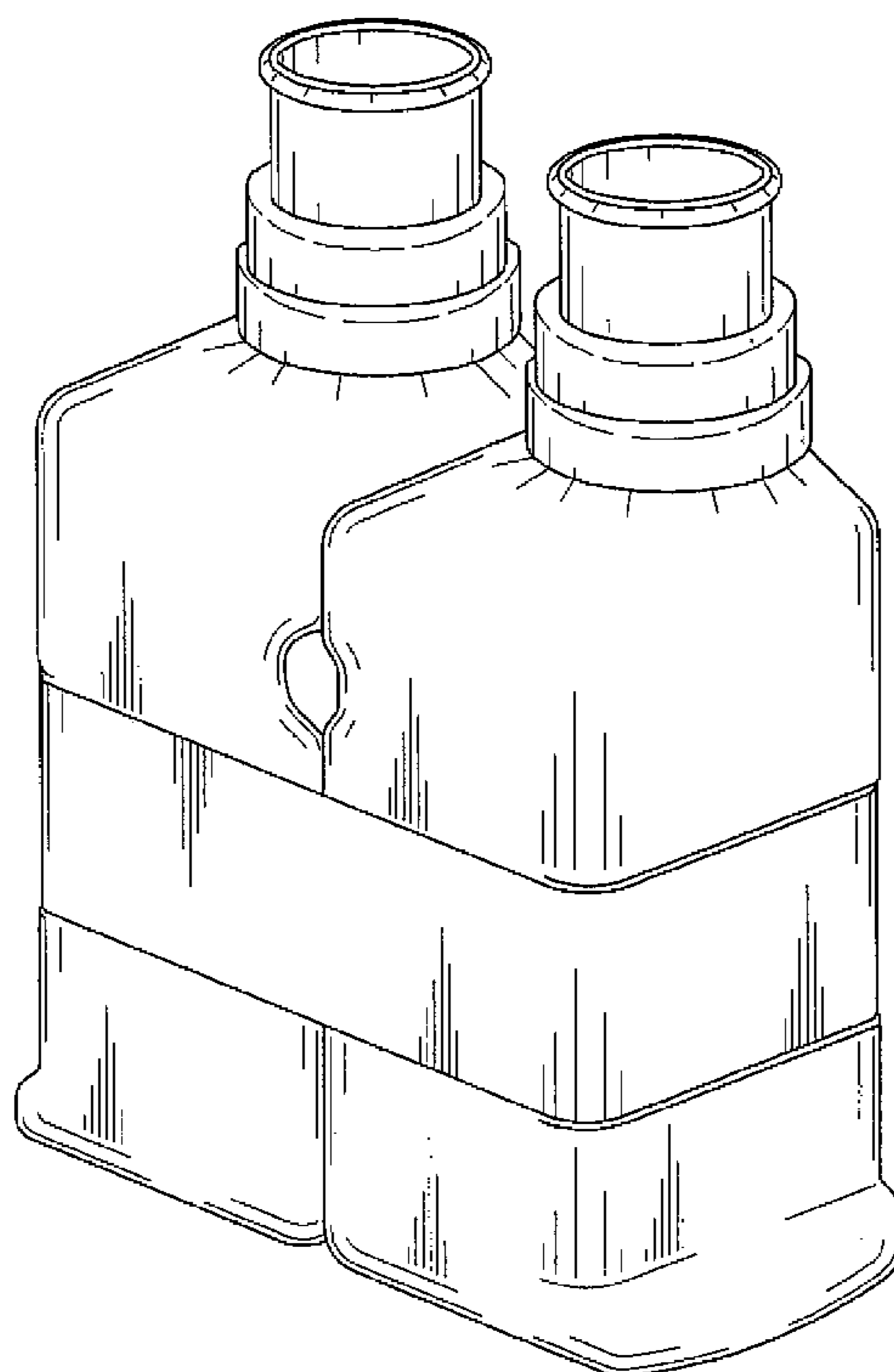

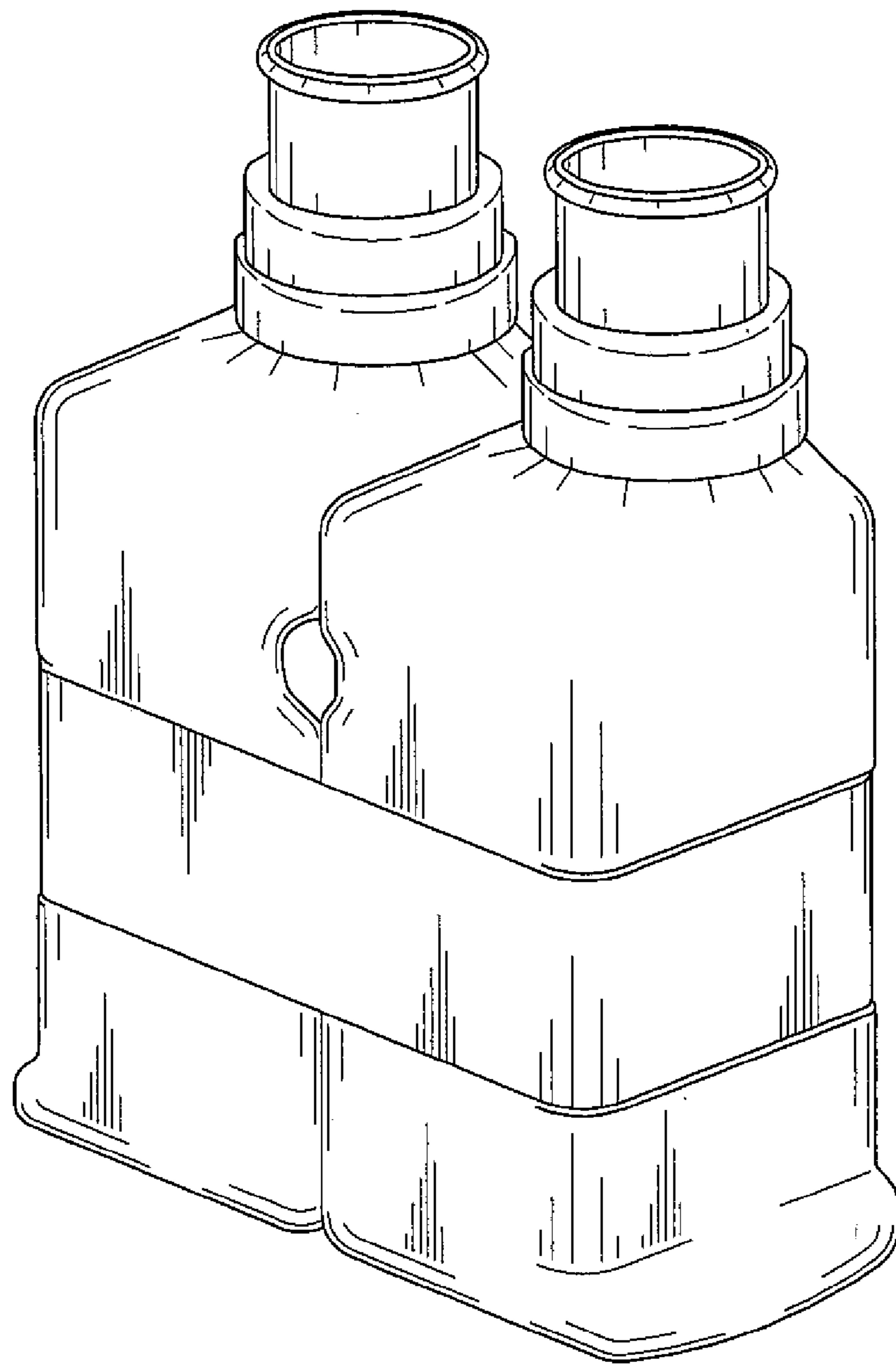

FIG. 1

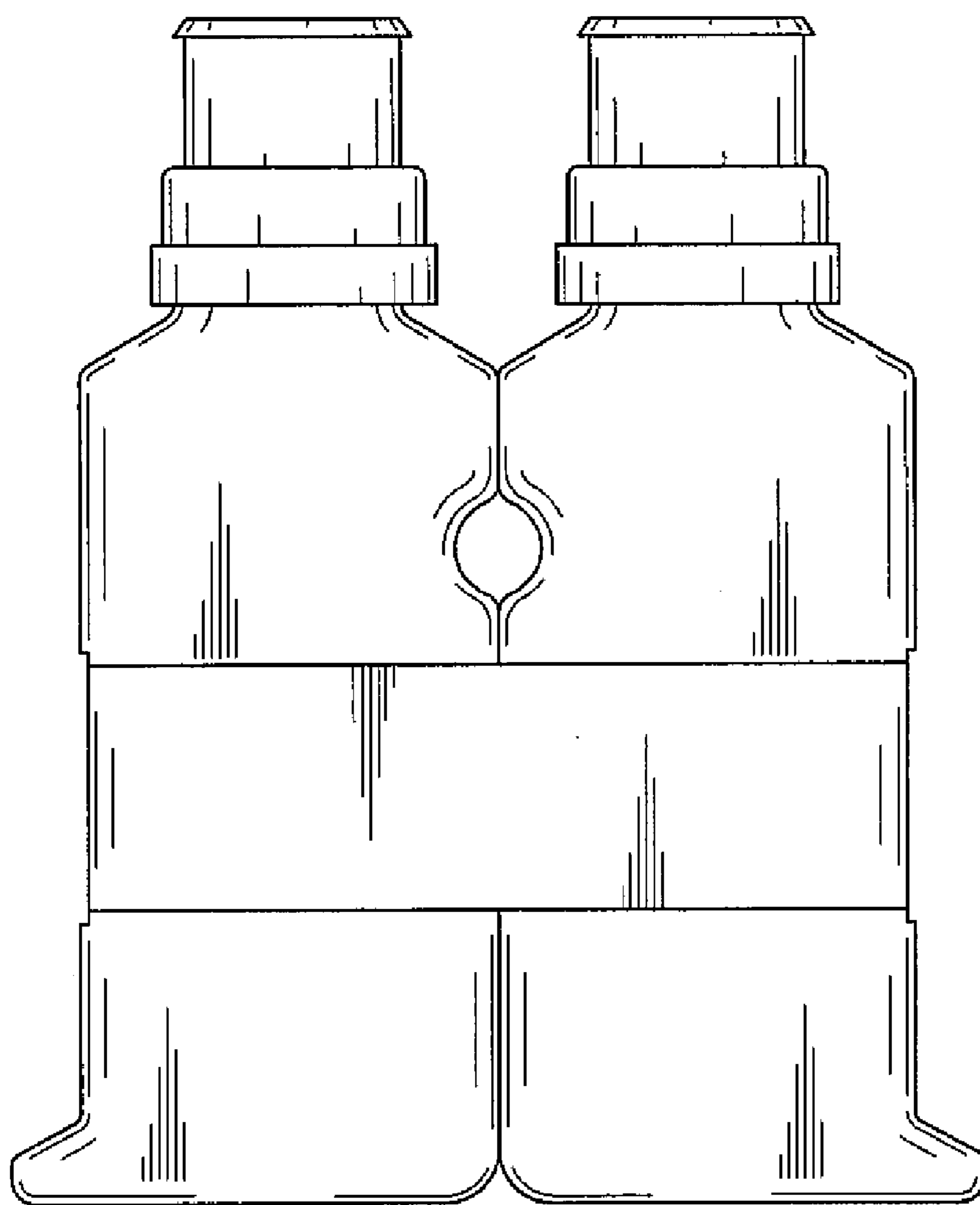

FIG. 2

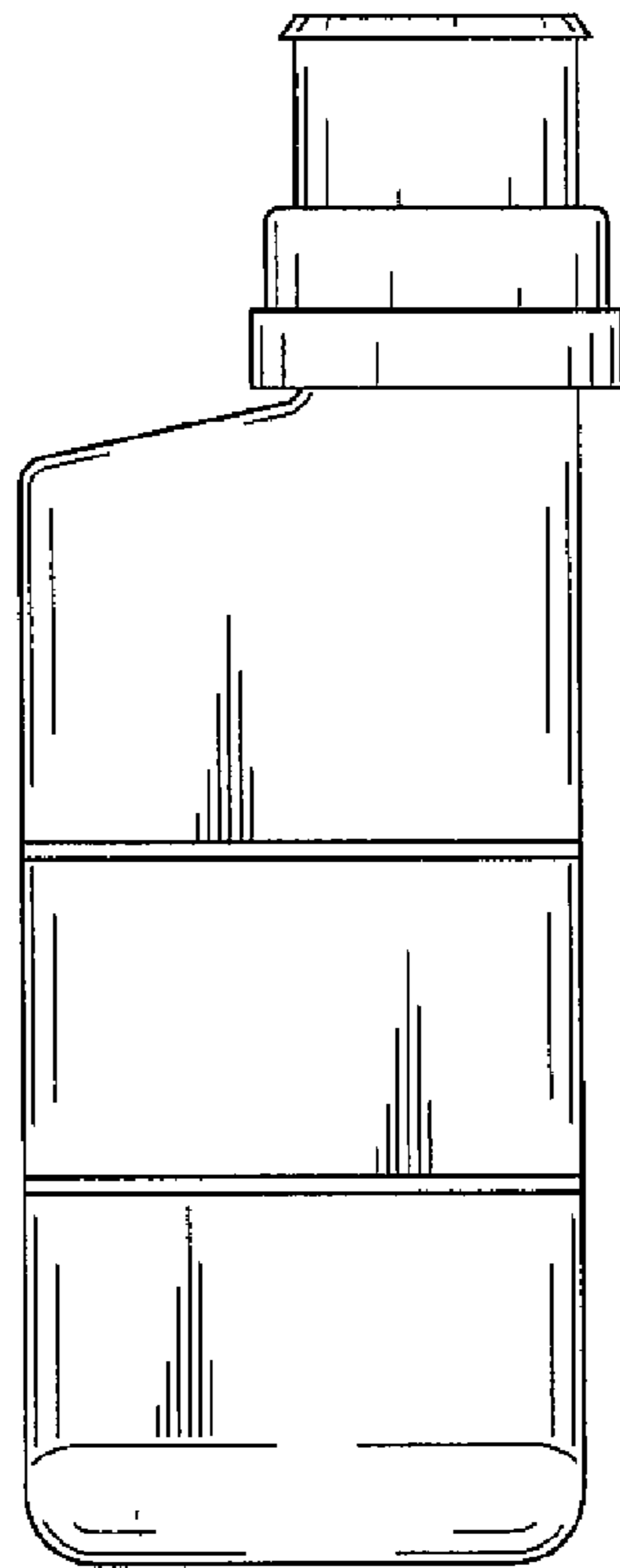

FIG. 3

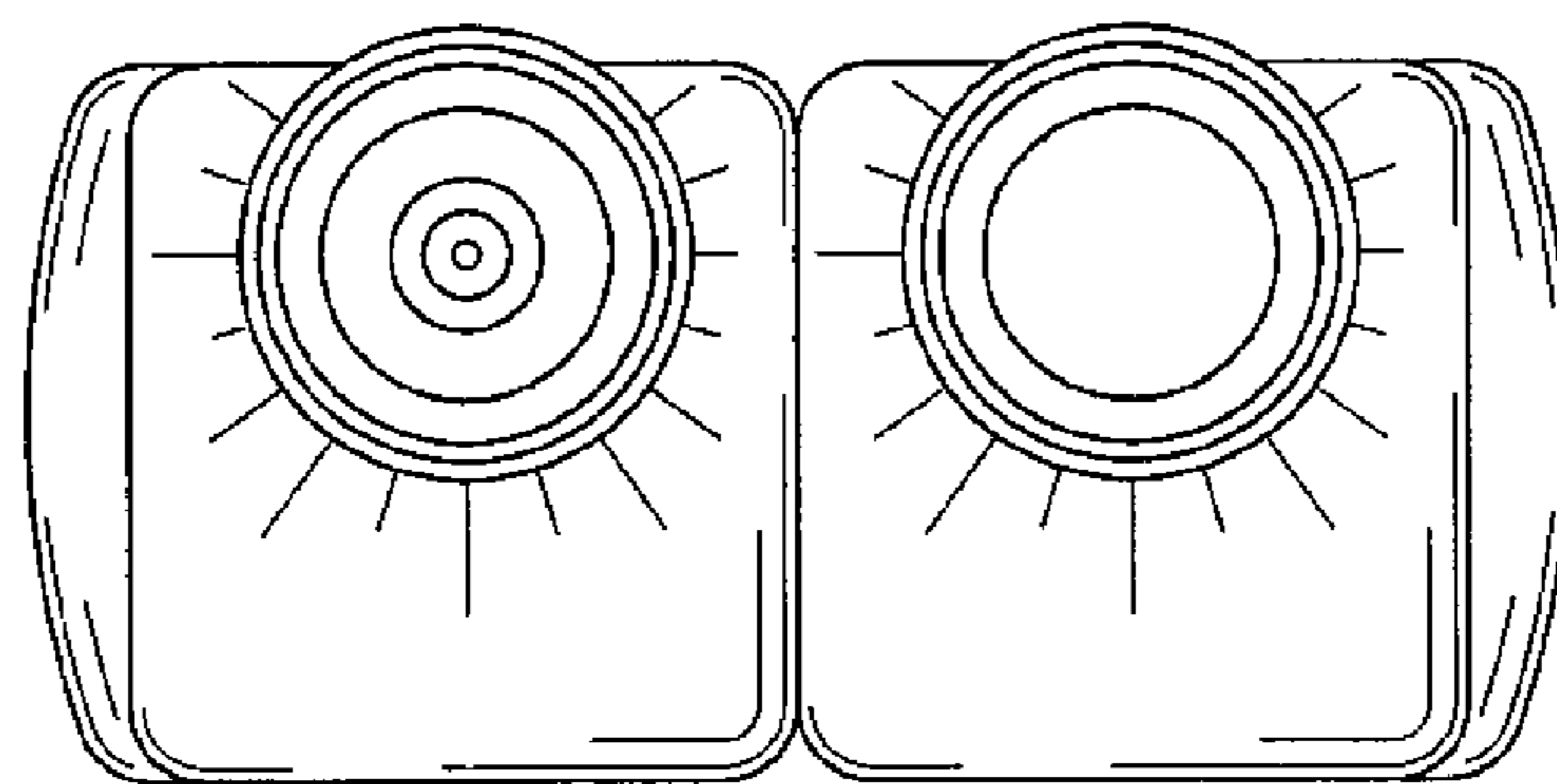

FIG. 4

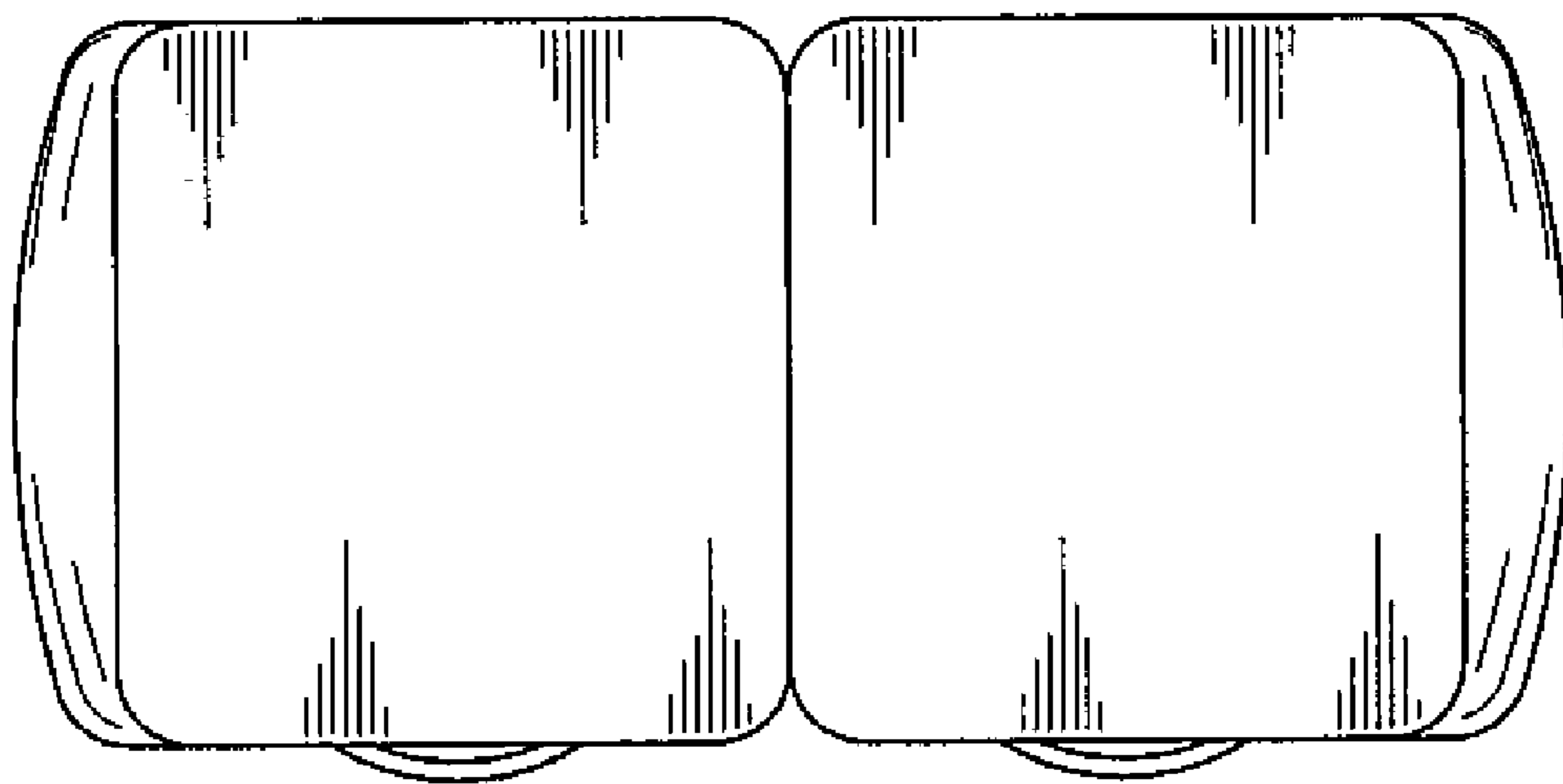

FIG. 5