



US00D569512S

(12) **United States Design Patent** (10) **Patent No.:** **US D569,512 S**
Poll et al. (45) **Date of Patent:** **** May 20, 2008**

(54) **FINGER MOUNTED LOCKING FORCEPS**

(75) Inventors: **Wayne Poll**, New Albany, OH (US);
Ran Oren, Kibbutz Gaaton (IL); **Eran Zakai**, Moshav Yodfat (IL); **Lee Ranon**, Nahayia (IL)

(73) Assignee: **Ethicon Endo-Surgery, Inc.**, Cincinnati, OH (US)

(**) Term: **14 Years**

(21) Appl. No.: **29/278,450**

(22) Filed: **Mar. 30, 2007**

(51) **LOC (8) Cl.** **24-02**

(52) **U.S. Cl.** **D24/143; D24/133**

(58) **Field of Classification Search** D24/133,
D24/143, 149; D28/55; 600/201, 197, 204,
600/109, 409; 606/205, 52-53, 1, 167, 206-210,
606/174, 180

See application file for complete search history.

(56) **References Cited**

U.S. PATENT DOCUMENTS

2,781,760	A *	2/1957	Baer	606/167
3,293,958	A *	12/1966	Smith	294/25
3,392,727	A *	7/1968	Hanlon	606/210
4,177,698	A *	12/1979	Greneker	81/177.3
D255,715	S *	7/1980	Markham	D24/143
D299,168	S *	12/1988	Bergstrom et al.	D24/143
5,125,923	A *	6/1992	Tanner et al.	606/10
5,329,832	A *	7/1994	Tegethoff	81/3.55
5,511,546	A *	4/1996	Hon	600/490
5,693,041	A *	12/1997	Murphy-Chutorian	606/2

5,697,889	A *	12/1997	Slotman et al.	600/204
5,803,322	A *	9/1998	Boone et al.	223/101
5,925,064	A *	7/1999	Meyers et al.	606/205
6,213,952	B1 *	4/2001	Finarov et al.	600/491
6,419,926	B2 *	7/2002	Kodama et al.	424/157.1
6,944,914	B2 *	9/2005	Tillim	16/430
7,211,091	B2 *	5/2007	Fowler et al.	606/142
2003/0220542	A1 *	11/2003	Belson et al.	600/109
2004/0193211	A1 *	9/2004	Voegele et al.	606/205
2004/0199204	A1 *	10/2004	Voegele et al.	606/205
2005/0267519	A1 *	12/2005	Tillim	606/210
2007/0239202	A1 *	10/2007	Rodriguez	606/205
2007/0250111	A1 *	10/2007	Lu et al.	606/205

* cited by examiner

Primary Examiner—Ian Simmons
Assistant Examiner—Wan Laymon

(74) *Attorney, Agent, or Firm*—Victor C. Moreno

(57) **CLAIM**

The ornamental design for a finger mounted locking forceps, as shown and described.

DESCRIPTION

FIG. 1 is a perspective view of a finger mounted locking forceps showing our new design;

FIG. 2 is a left side view thereof;

FIG. 3 is a right side view thereof;

FIG. 4 is a top plan view thereof;

FIG. 5 is a bottom plan view thereof;

FIG. 6 is a front view thereof; and,

FIG. 7 is a rear view thereof.

1 Claim, 5 Drawing Sheets

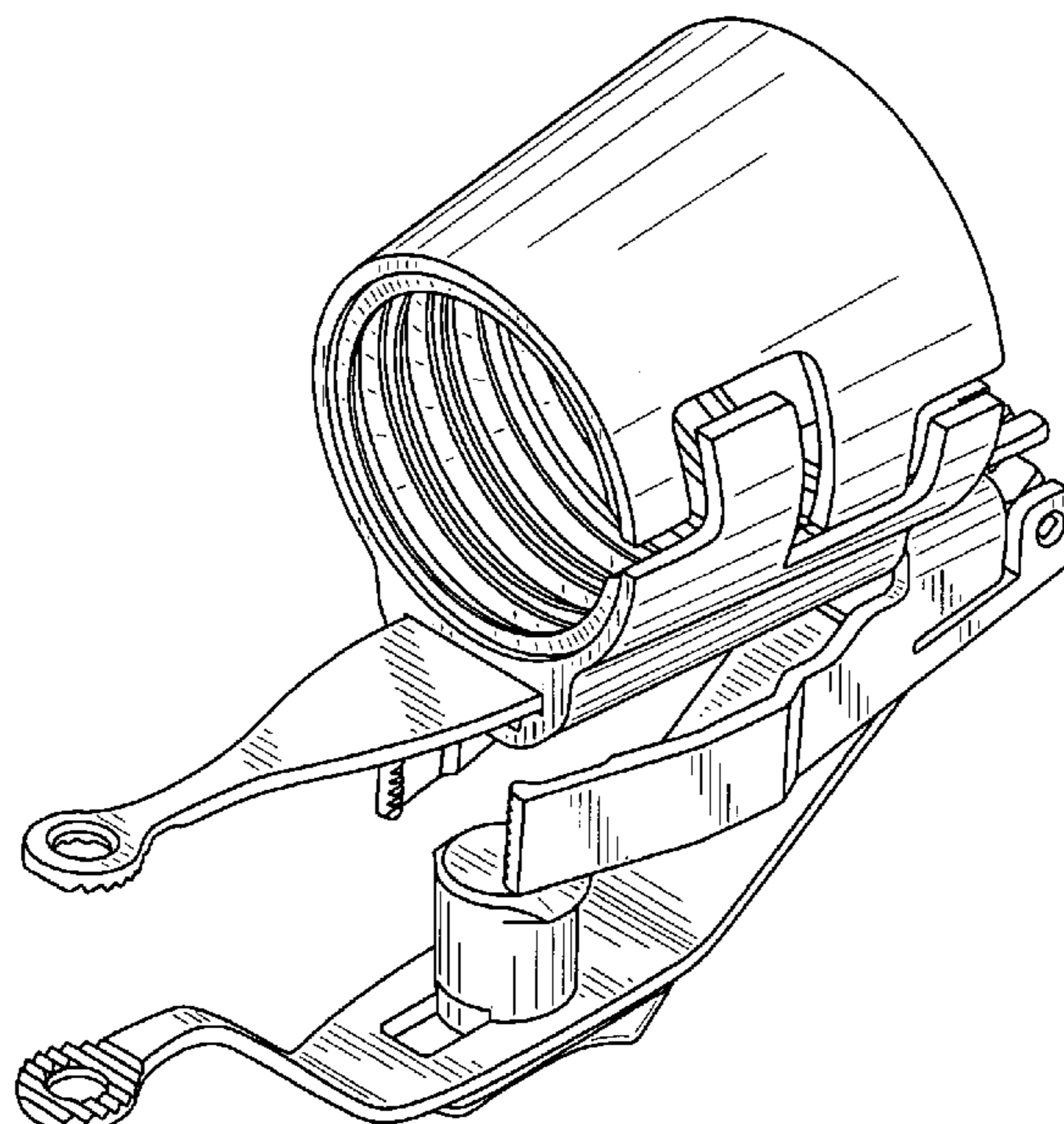

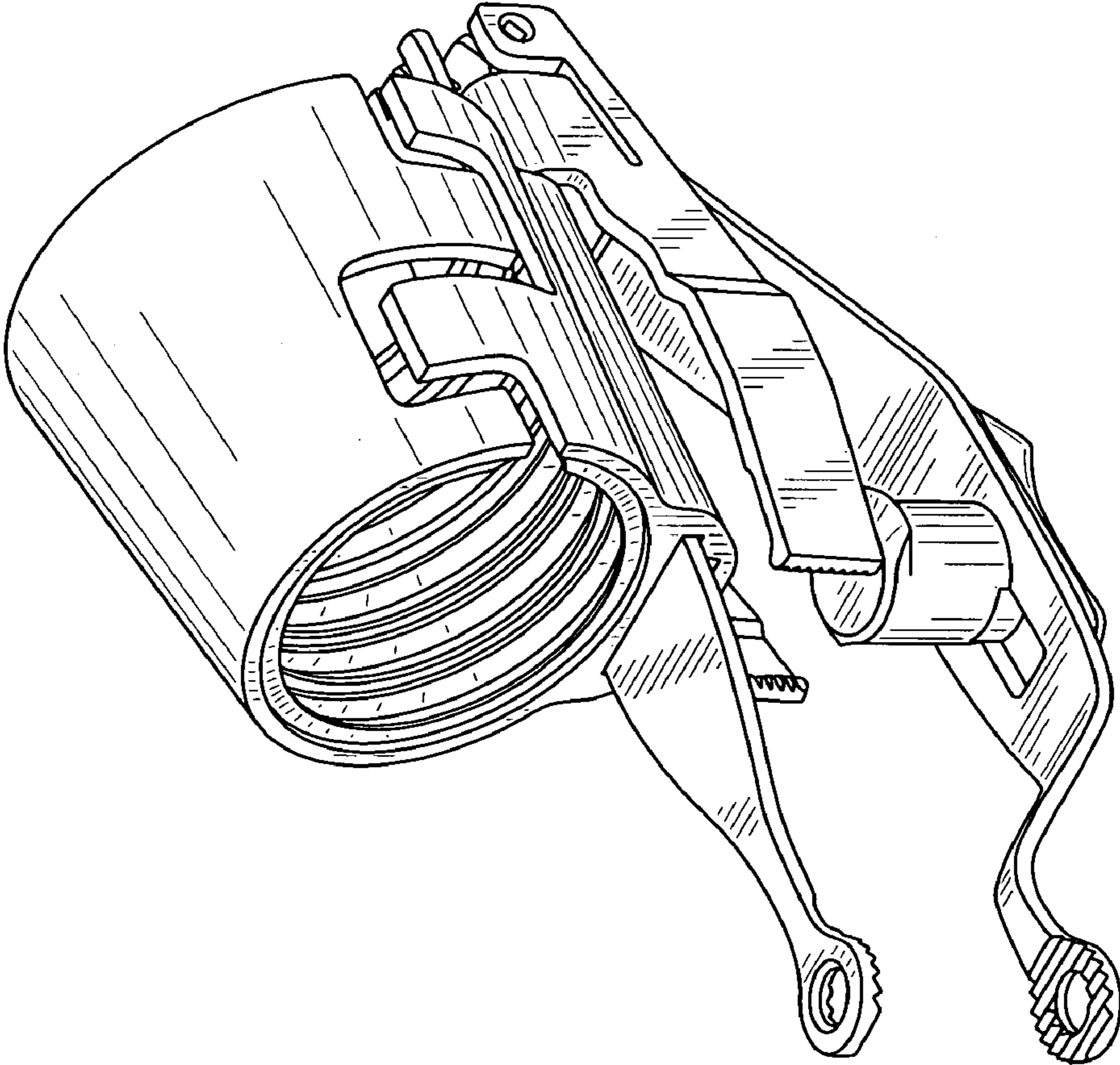

FIG. 1

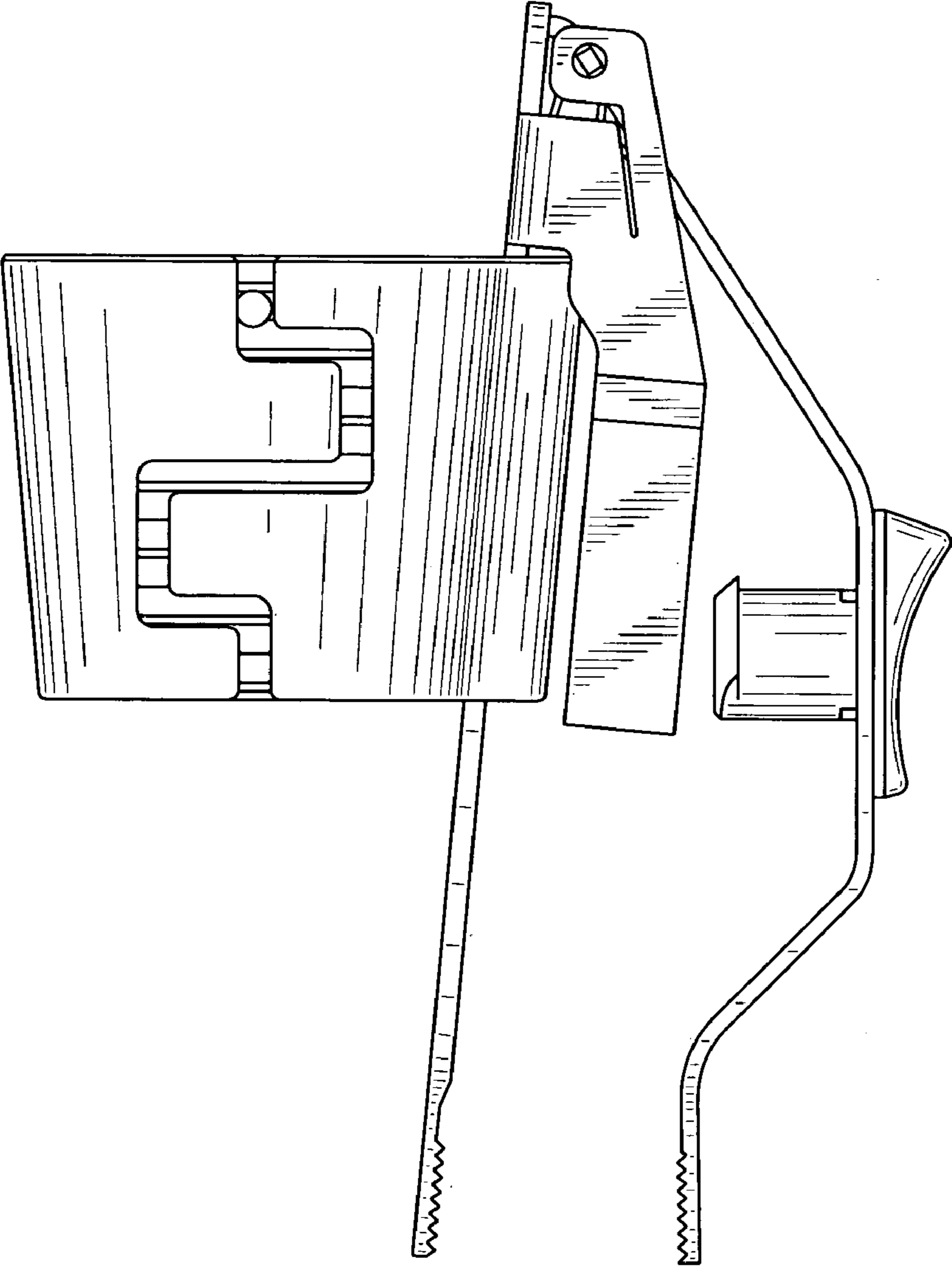

FIG. 2

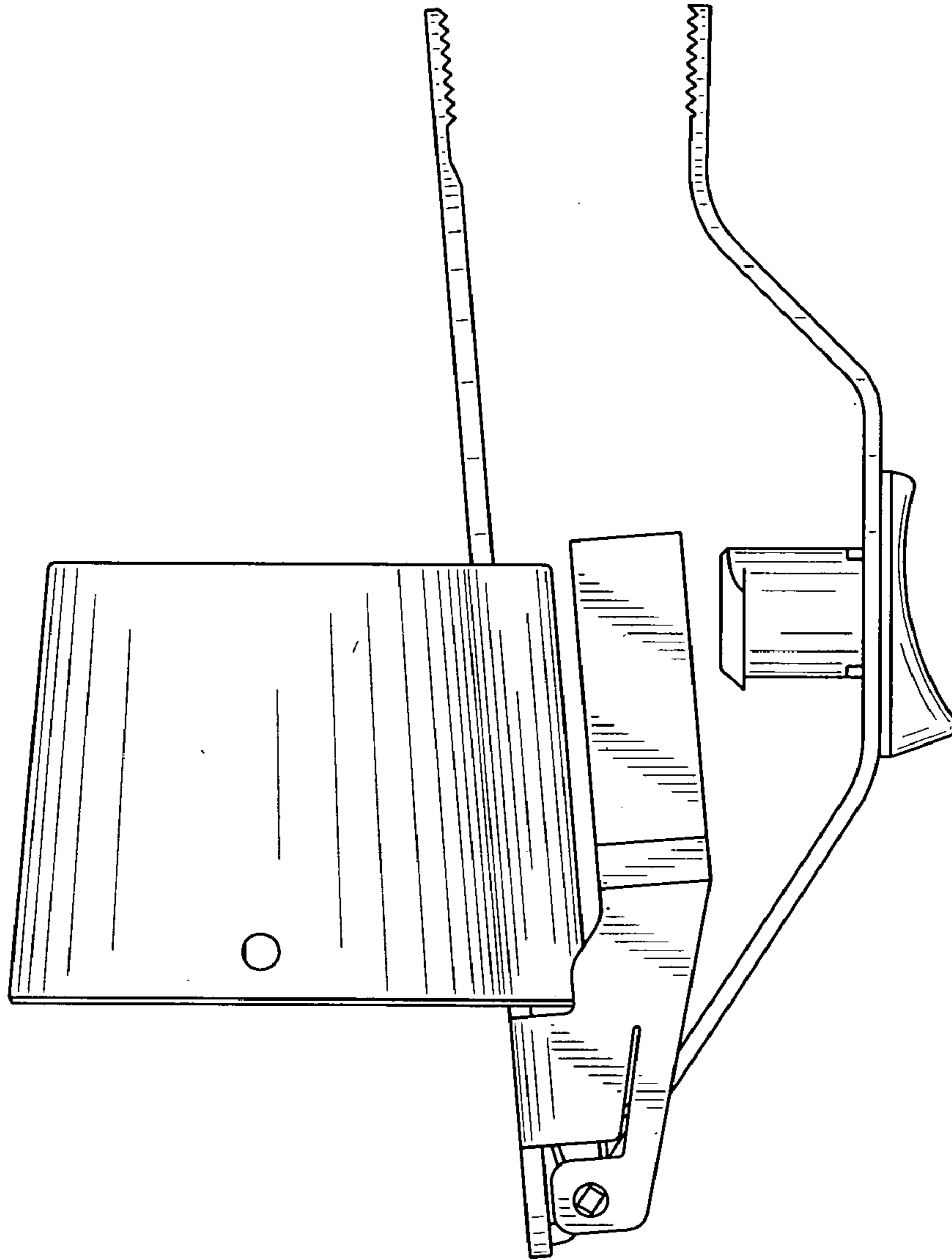

FIG. 3

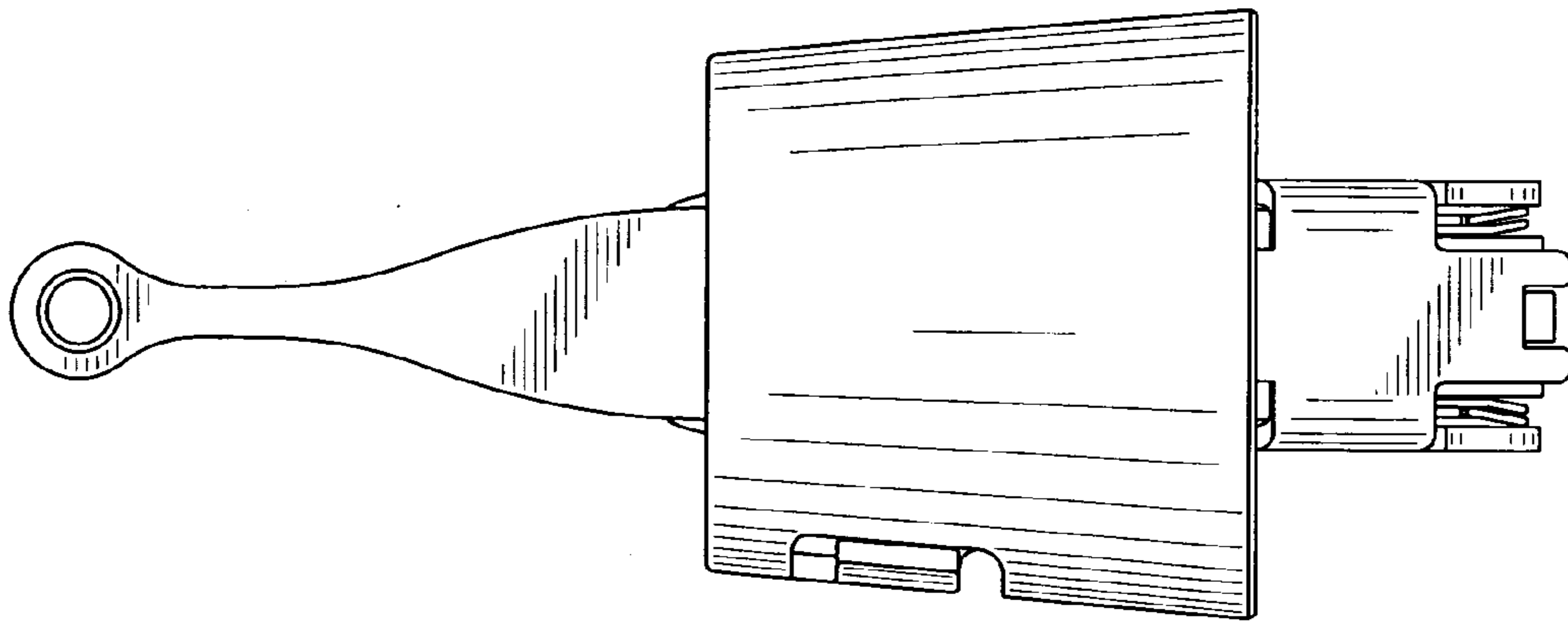

FIG. 4

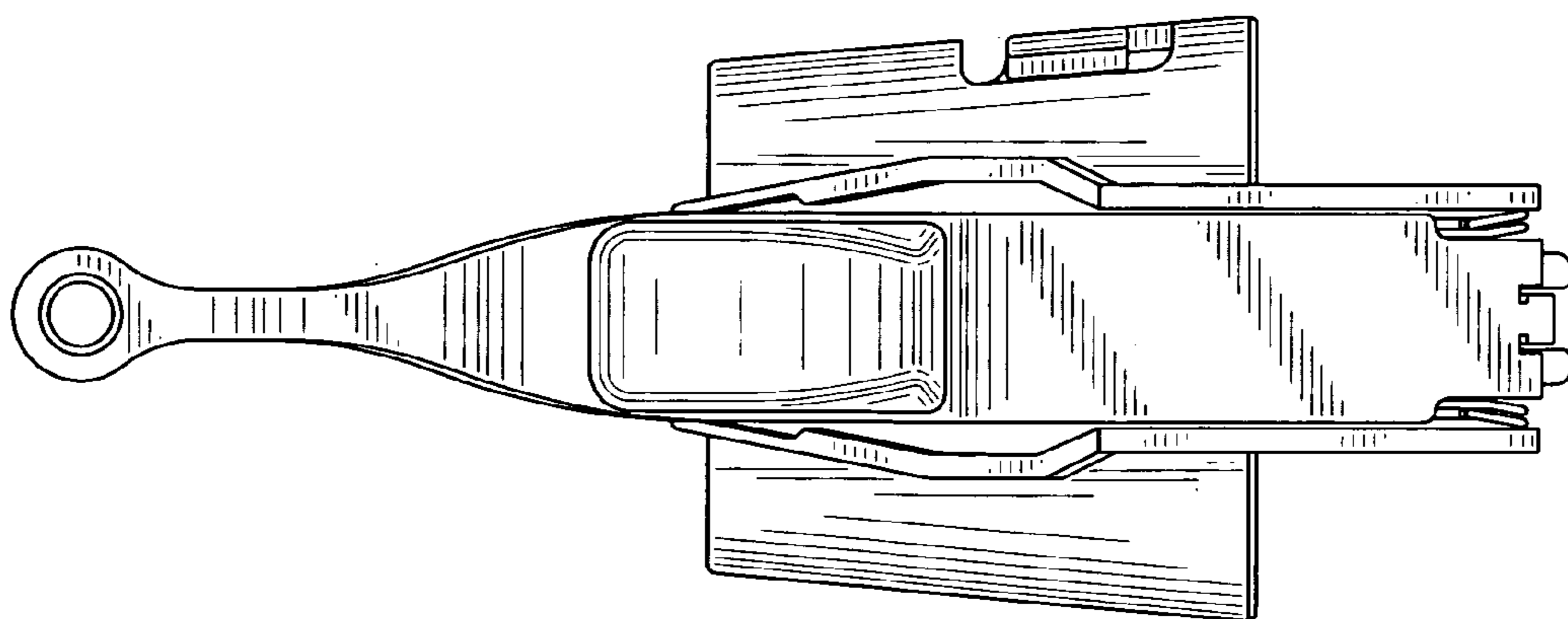

FIG. 5

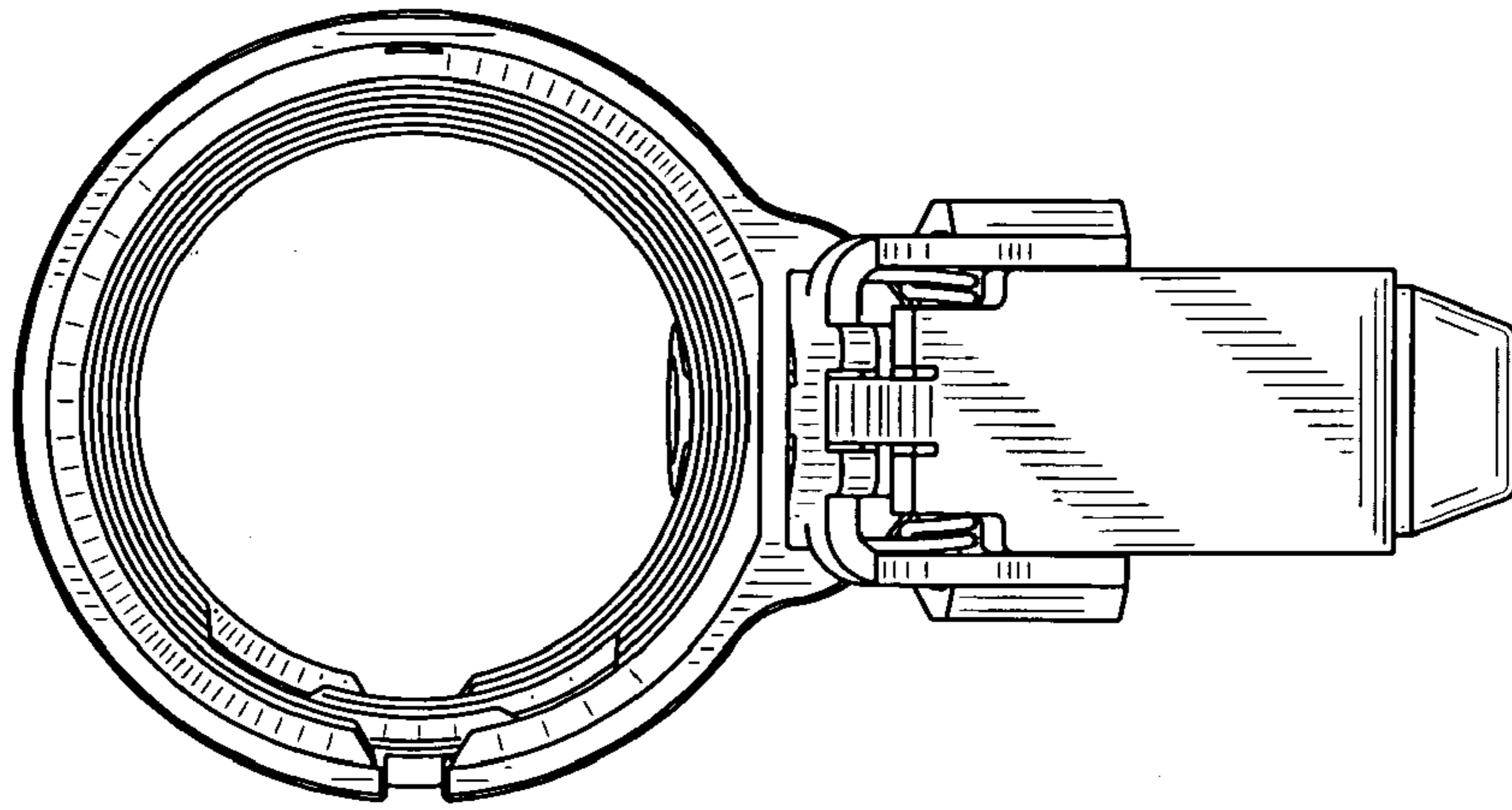

FIG. 7

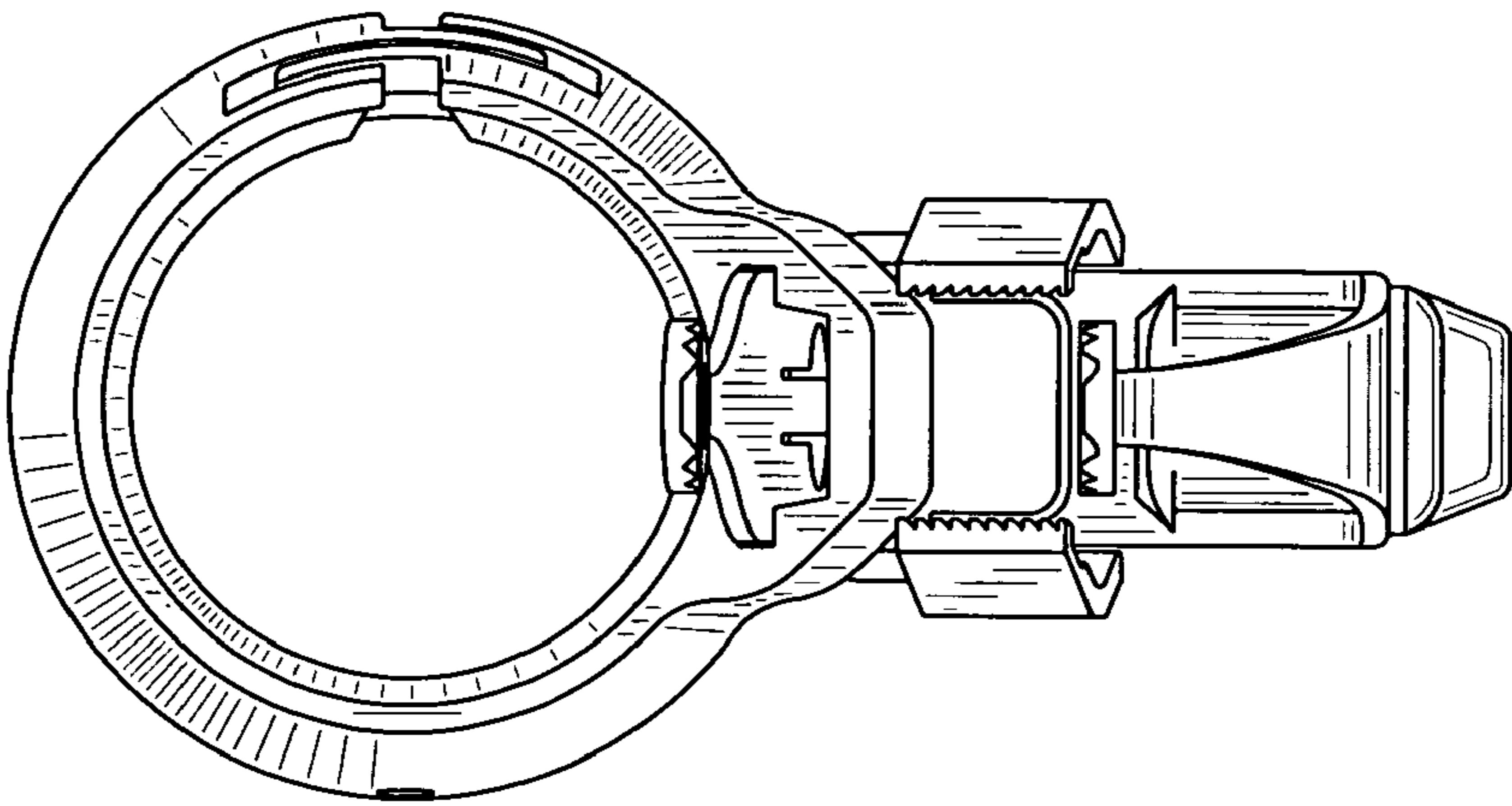

FIG. 6