

US00D569313S

(12) **United States Design Patent** (10) **Patent No.:** **US D569,313 S**
Körner et al. (45) **Date of Patent:** **** May 20, 2008**

(54) **SUSPENSION STRUT**

(75) Inventors: **Thomas Körner**, Uppsala (SE);
Christer Lööv, Stockholm (SE)

(73) Assignee: **Ohlins Racing AB**, Upplands Vasby (SE)

(**) Term: **14 Years**

(21) Appl. No.: **29/247,221**

(22) Filed: **Jun. 6, 2006**

(30) **Foreign Application Priority Data**

Dec. 14, 2005 (SE) 05-0726

(51) **LOC (8) Cl.** **12-16**

(52) **U.S. Cl.** **D12/159**

(58) **Field of Classification Search** D12/159,
D12/161, 400; 280/86.752, 11.225; 293/134;
188/281, 298, 297, 315, 316, 27, 286; 267/195
See application file for complete search history.

(56) **References Cited**

U.S. PATENT DOCUMENTS

D123,687 S *	11/1940	Beecher	D12/159
D233,743 S *	11/1974	Hobbins	D12/159
D239,377 S *	3/1976	Castelli	D12/159
D346,780 S *	5/1994	Homme	D12/159
D346,781 S *	5/1994	Homme	D12/159
D357,951 S *	5/1995	Chen	D12/159
7,191,877 B2 *	3/2007	Norgaard et al.	188/274

OTHER PUBLICATIONS

BOS engineering suspensions; techstore; ;2005; website page;
<http://www.bos-engineering.com/boutique>; 5 pages.

* cited by examiner

Primary Examiner—Louis Zarfaz
Assistant Examiner—Michael A. Pratt

(74) *Attorney, Agent, or Firm*—Knobbe, Martens, Olson & Bear, LLP

(57) **CLAIM**

The ornamental design for a suspension strut, as shown and described.

DESCRIPTION

FIG. 1 is a top perspective of a first embodiment view of a suspension strut;

FIG. 2 is a front view of the suspension strut of FIG. 1;

FIG. 3 is a rear view of the suspension strut of FIG. 1;

FIG. 4 is a right side view of the suspension strut of FIG. 1 and the left side view is a mirror image of the right side view;

FIG. 5 is a top view of the suspension strut of FIG. 1;

FIG. 6 is a bottom view of the suspension strut of FIG. 1;

FIG. 7 is a bottom perspective view of the suspension strut of FIG. 1;

FIG. 8 is a top perspective view of a second embodiment of a suspension strut;

FIG. 9 is a front view of the suspension strut of FIG. 8;

FIG. 10 is a rear view of the suspension strut of FIG. 8;

FIG. 11 is a right side view of the suspension strut of FIG. 8 and the left side view is a mirror image of the right side view;

FIG. 12 is a top view of the suspension strut of FIG. 8;

FIG. 13 is a bottom view of the suspension strut of FIG. 8; and,

FIG. 14 is a bottom perspective view of the suspension strut of FIG. 8.

The broken lines showing of elements of the suspension strut is included for the purpose of illustrating environment and forms no part of the claimed design.

1 Claim, 12 Drawing Sheets

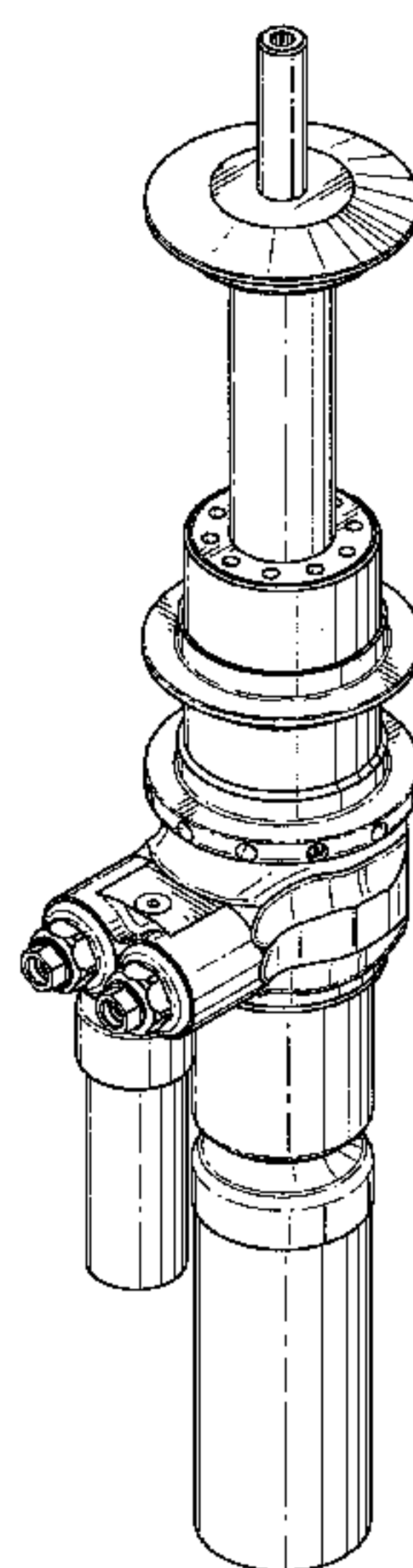

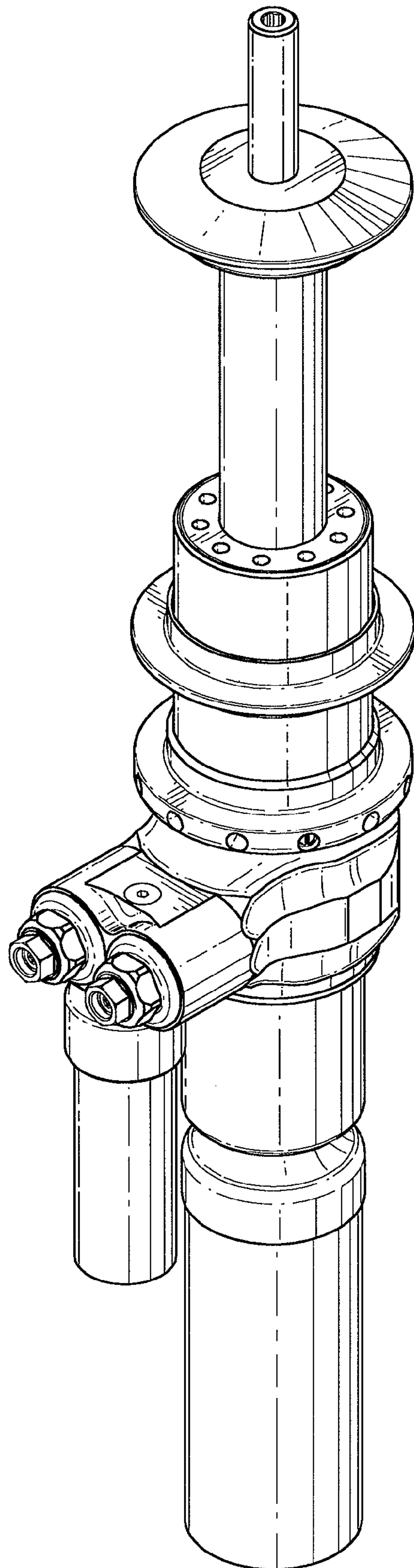

FIG. 1

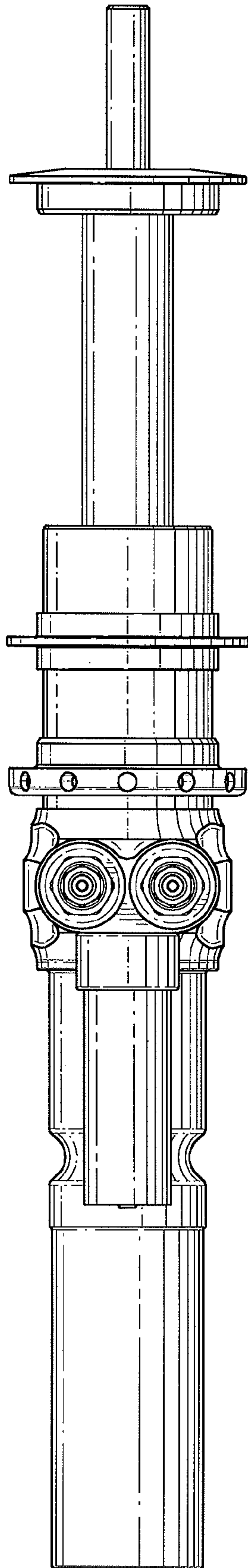

FIG. 2

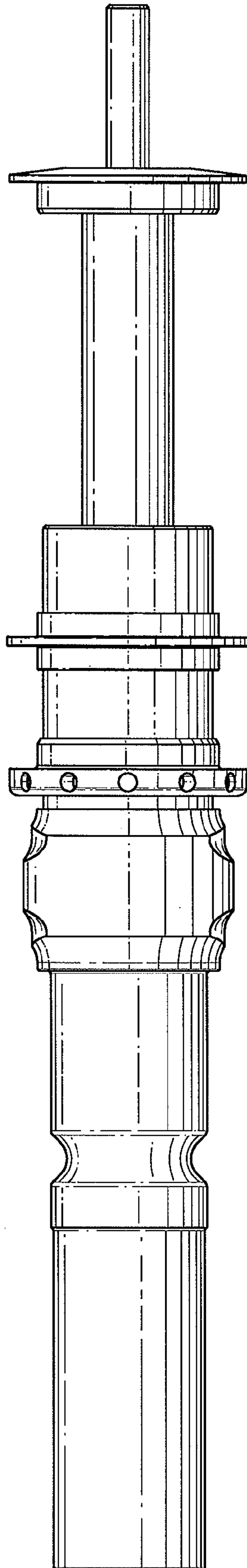

FIG. 3

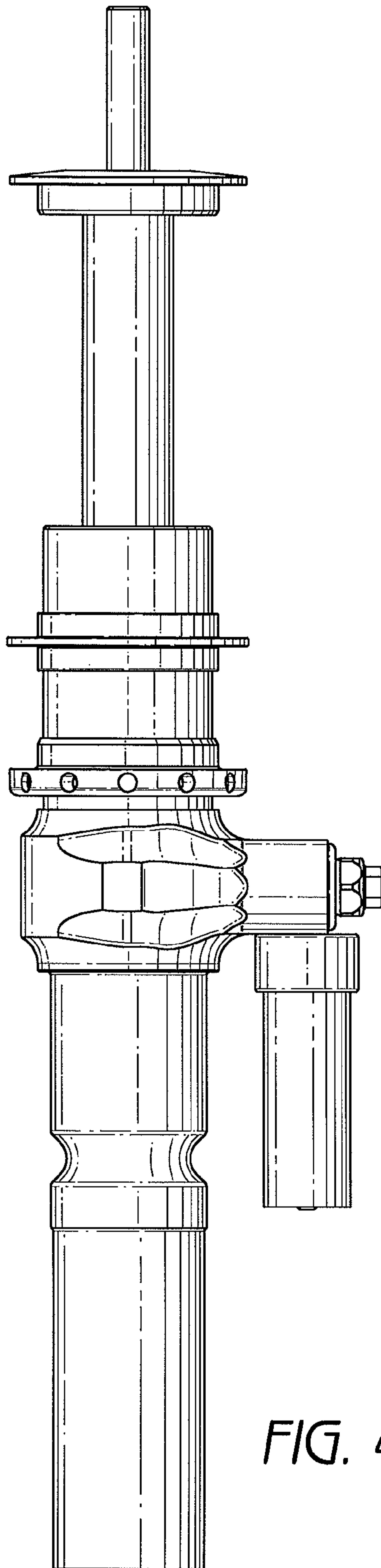

FIG. 4

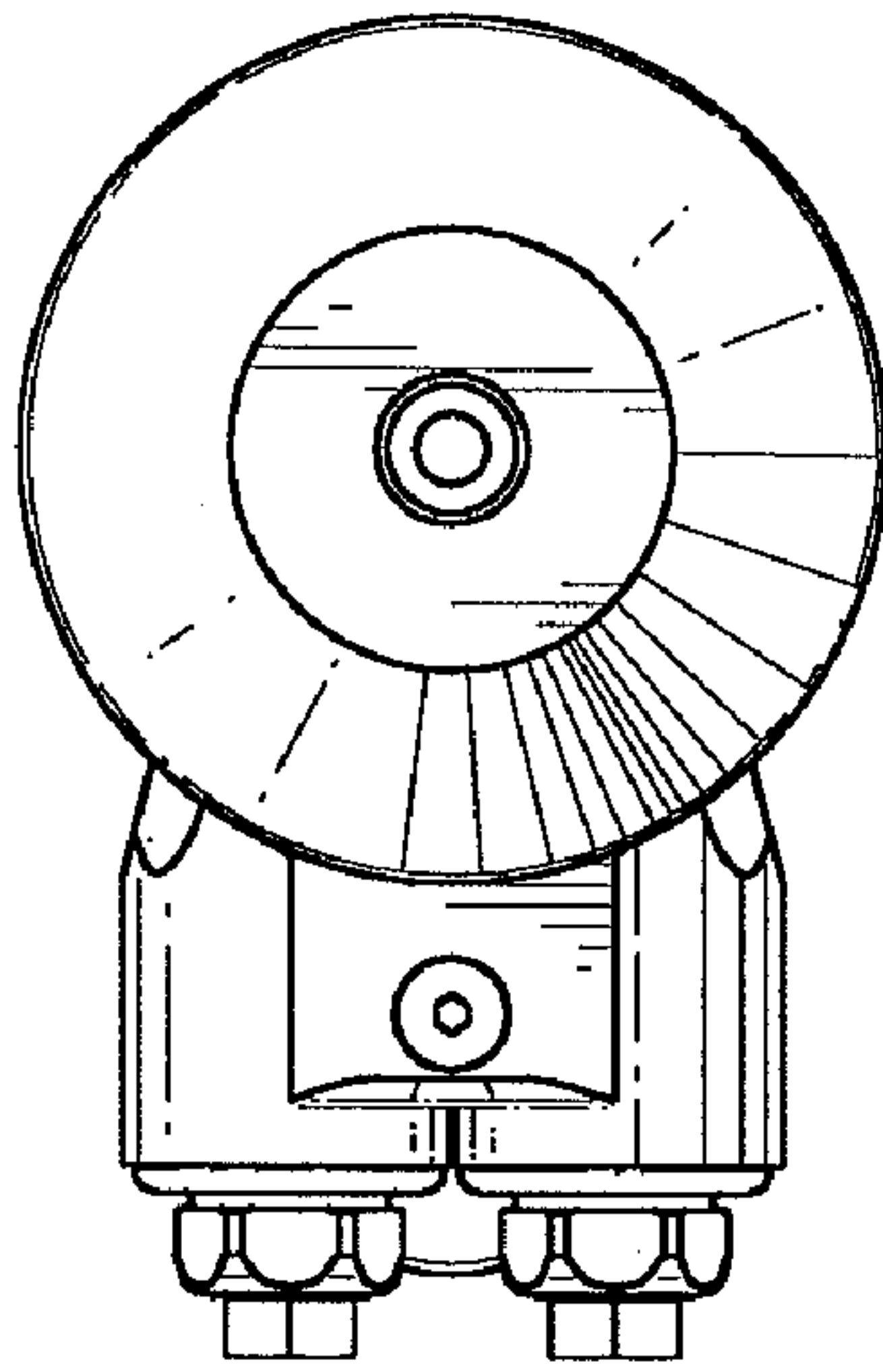

FIG. 5

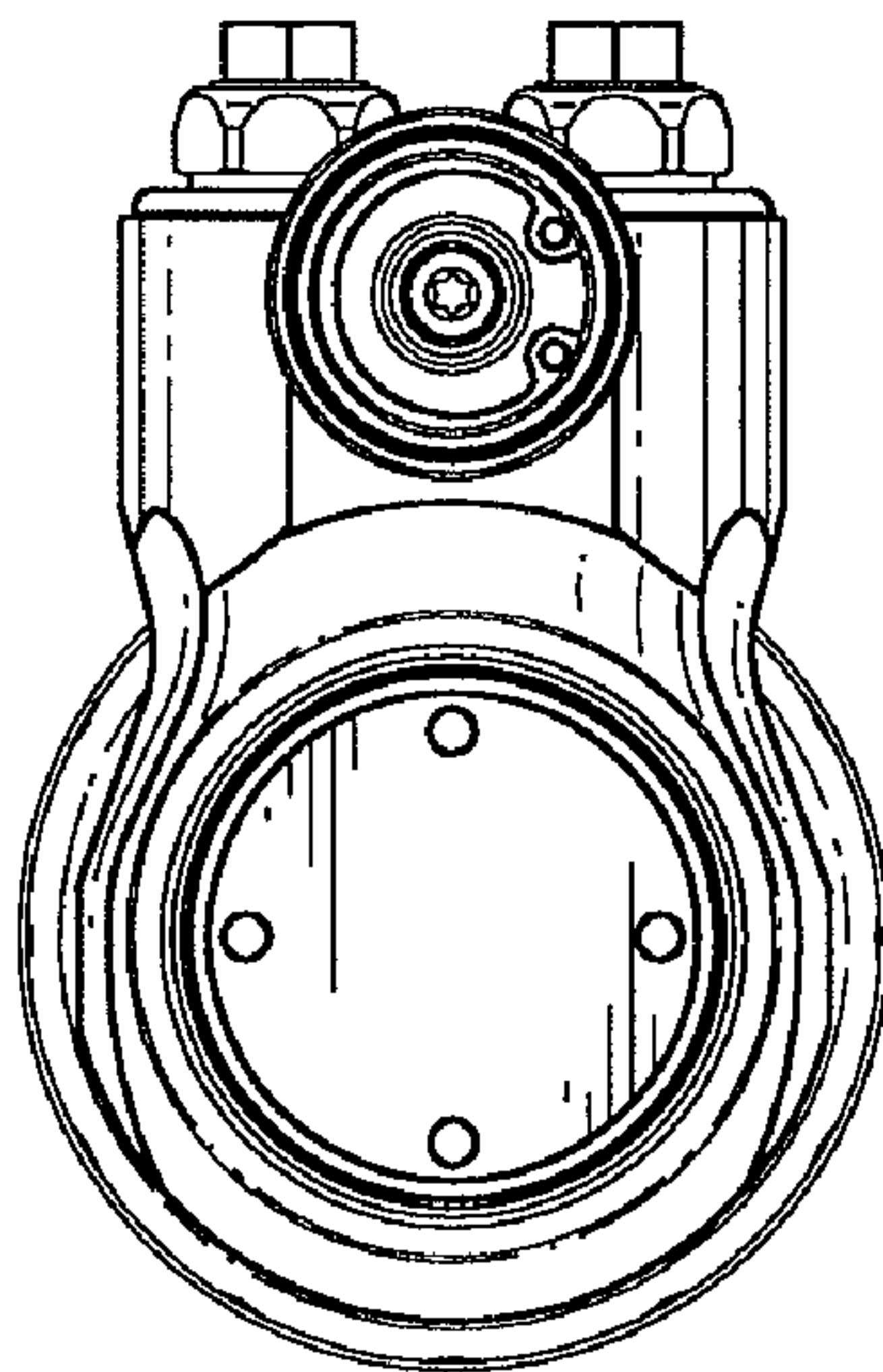

FIG. 6

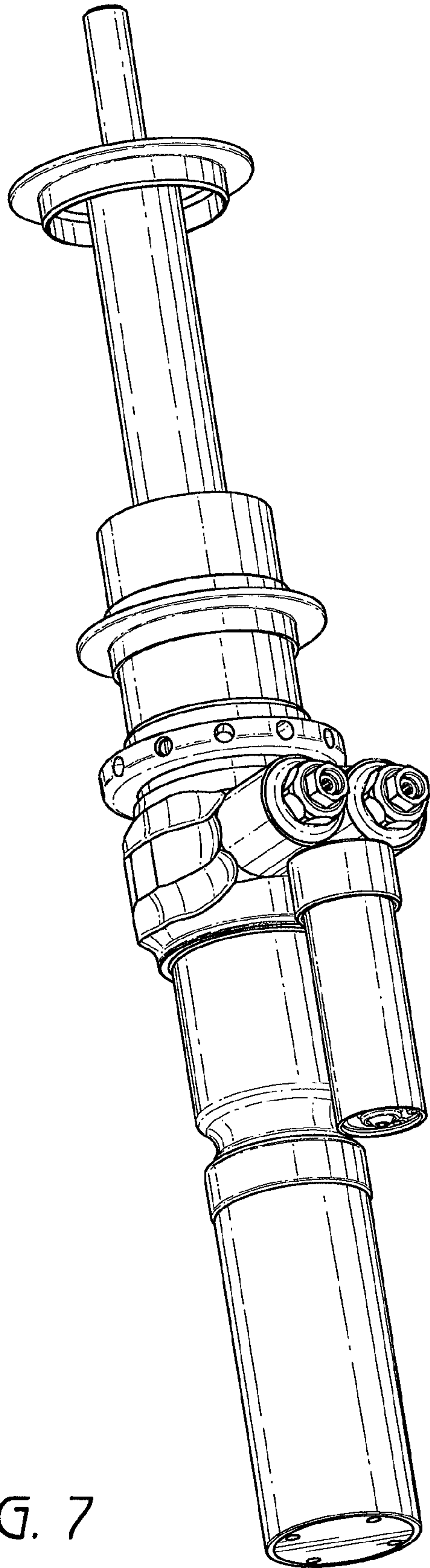

FIG. 7

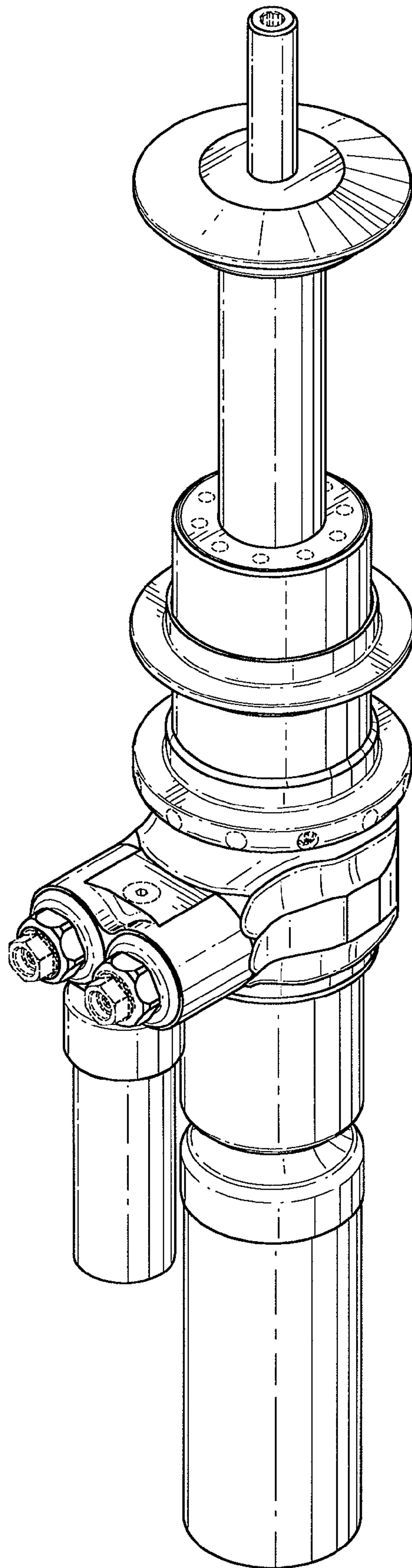

FIG. 8

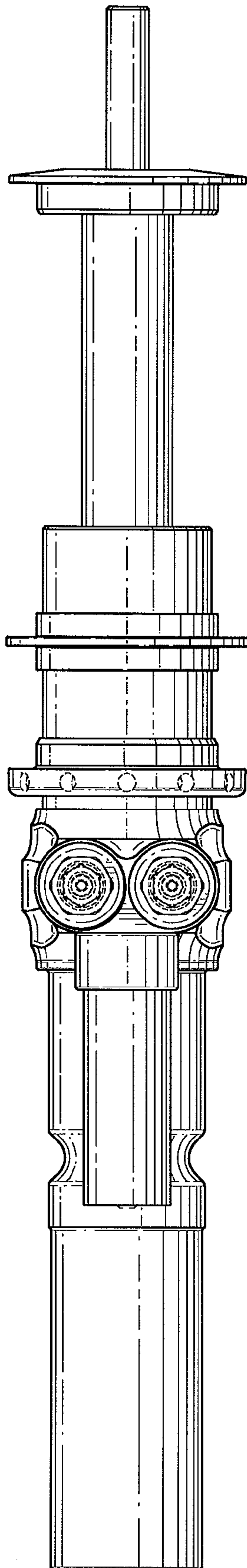

FIG. 9

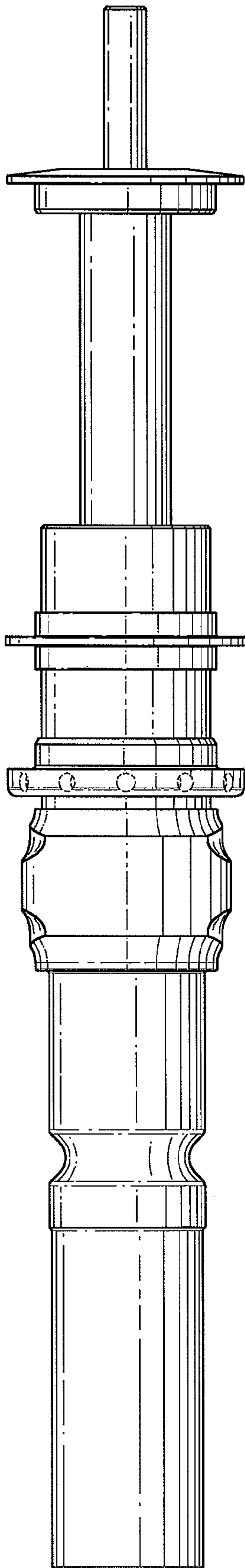

FIG. 10

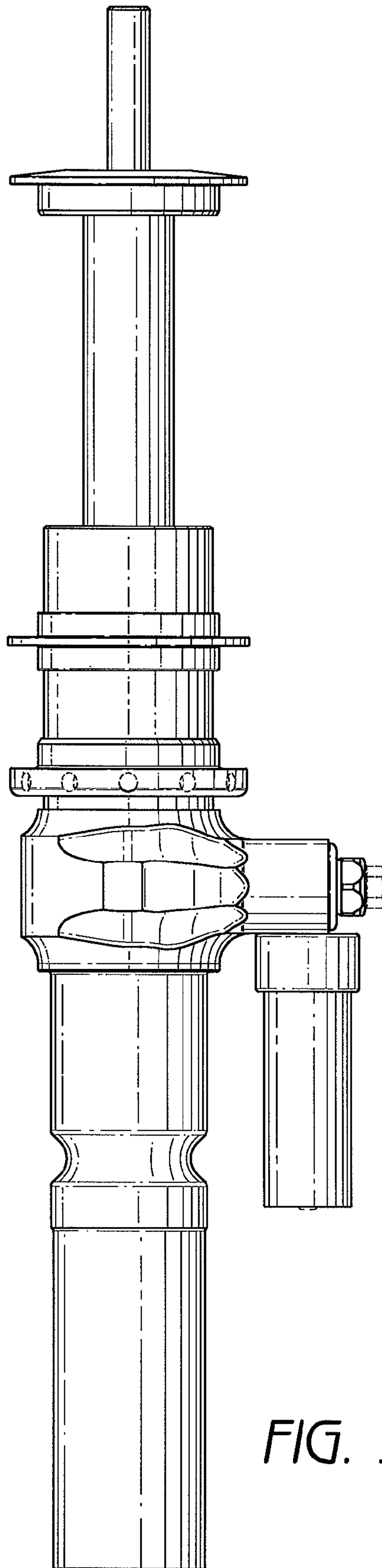

FIG. 11

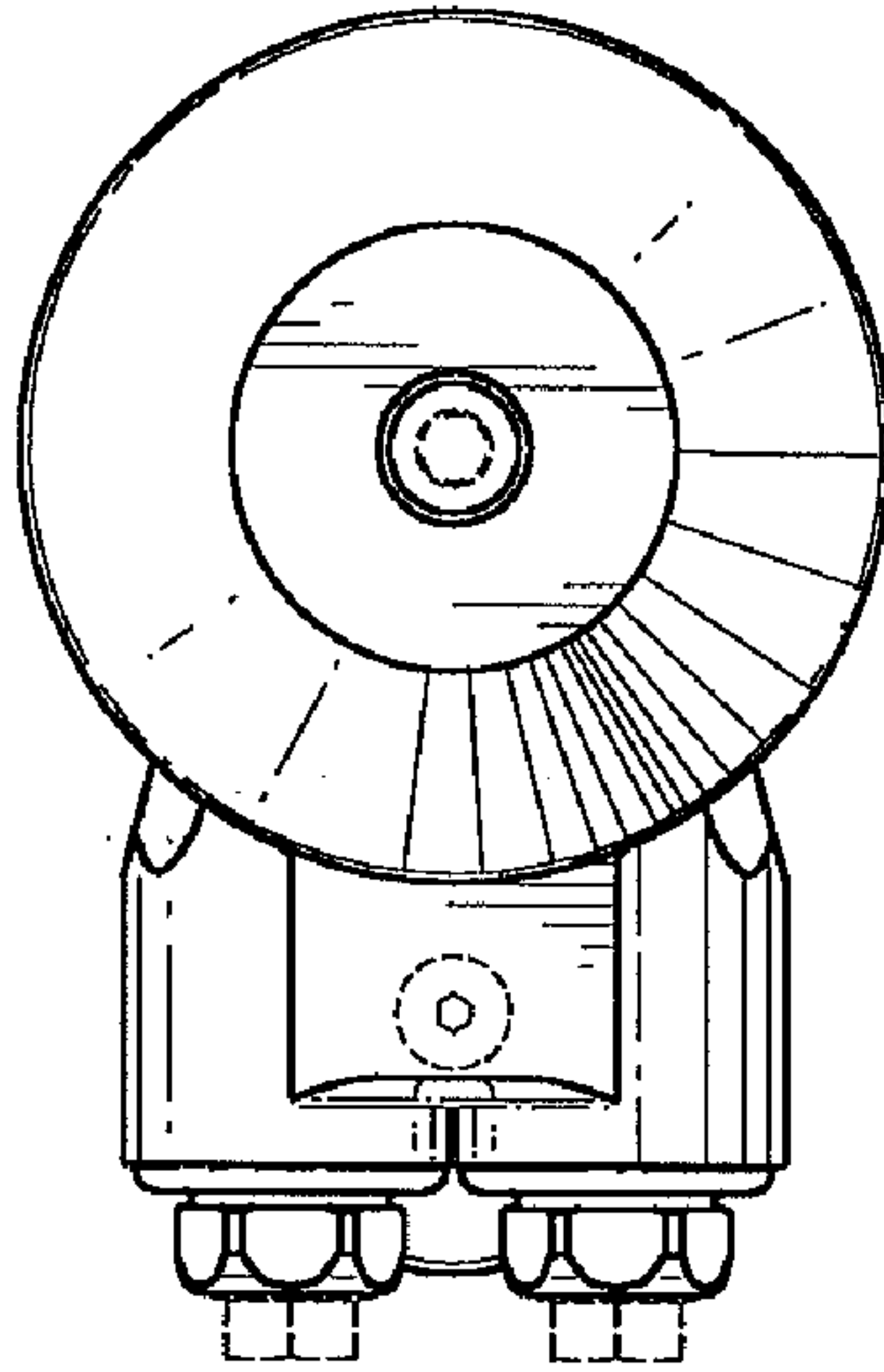

FIG. 12

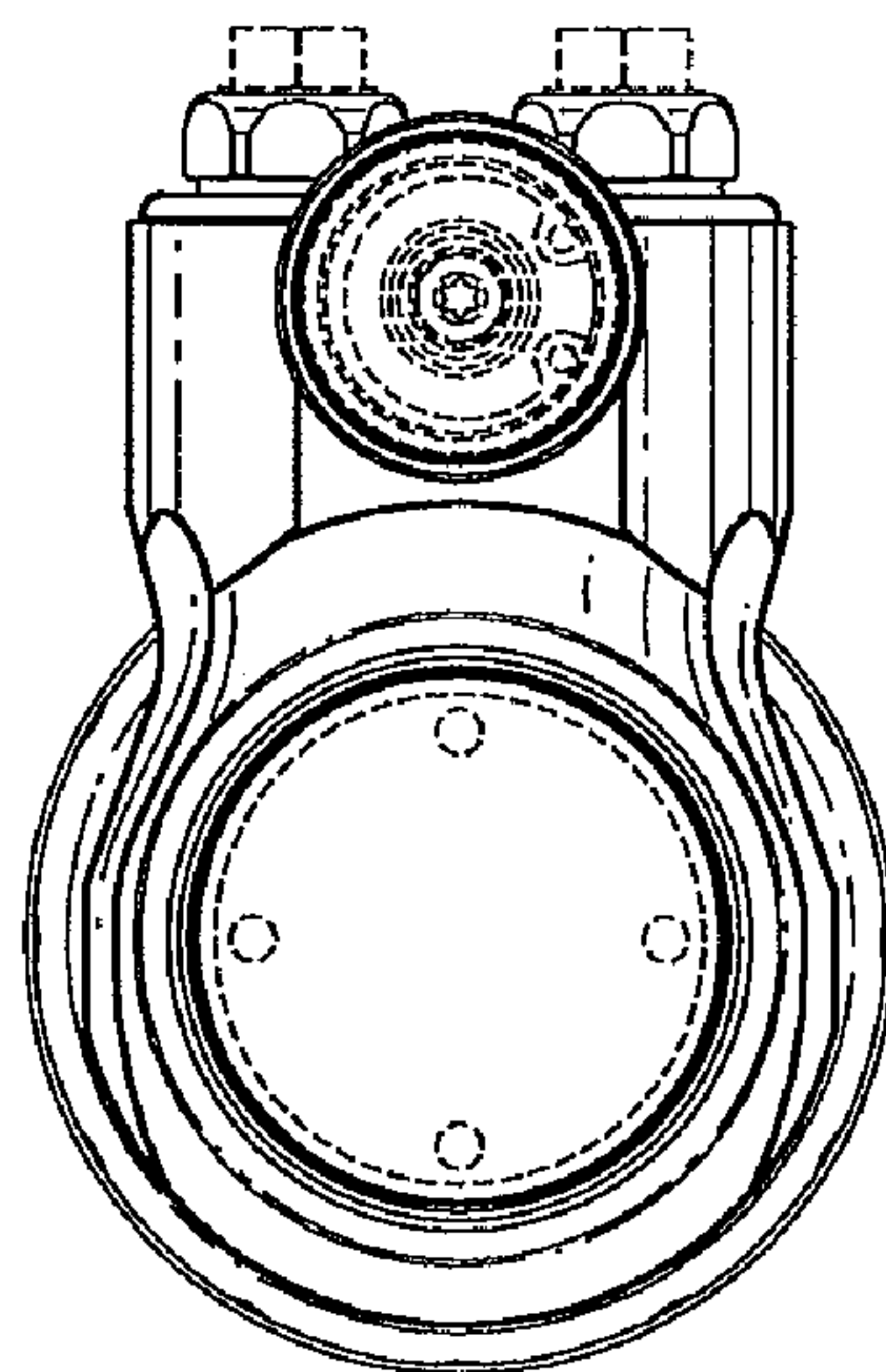

FIG. 13

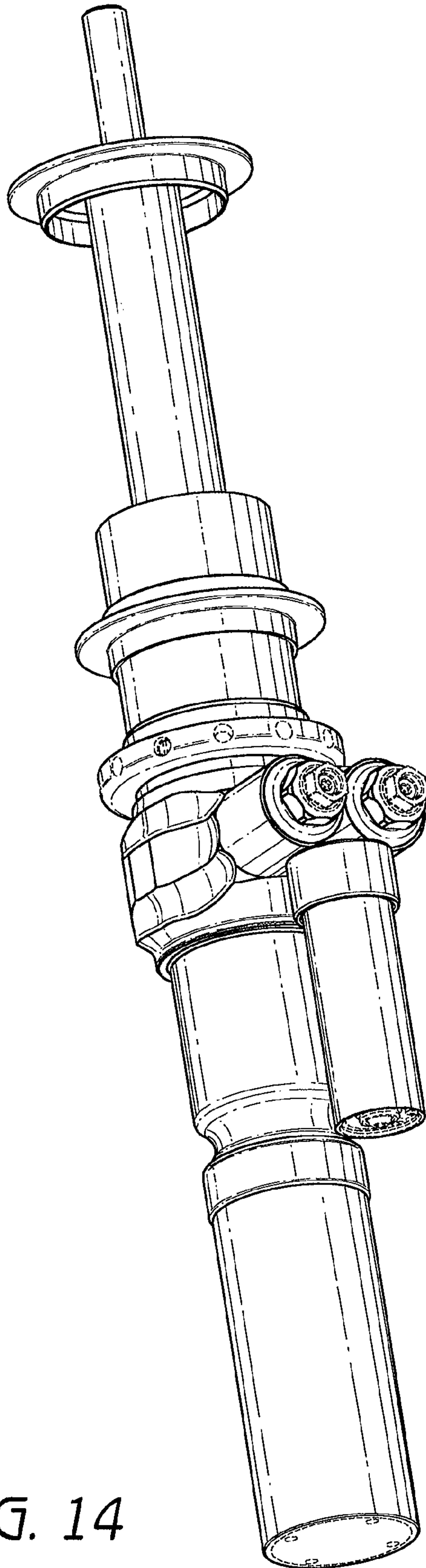

FIG. 14