



US00D568821S

(12) **United States Design Patent**
Ashida et al.

(10) **Patent No.:** **US D568,821 S**
(45) **Date of Patent:** **** May 13, 2008**

(54) **CONNECTOR PLUG FOR ELECTRONIC GAME MACHINE**

(75) Inventors: **Kenichiro Ashida**, Kyoto (JP); **Junji Takamoto**, Kyoto (JP); **Yoshitomo Goto**, Kyoto (JP); **Masato Ibuki**, Kyoto (JP); **Shinji Yamamoto**, Kyoto (JP); **Hirokazu Matsui**, Kyoto (JP); **Daisuke Kumazaki**, Kyoto (JP); **Fumiyoshi Suetake**, Kyoto (JP); **Akiko Suga**, Kyoto (JP)

(73) Assignee: **Nintendo Co. Ltd.**, Kyoto (JP)

(**) Term: **14 Years**

(21) Appl. No.: **29/287,632**

(22) Filed: **Aug. 30, 2007**

Related U.S. Application Data

(62) Division of application No. 29/268,252, filed on Nov. 2, 2006, now Pat. No. Des. 558,677.

(30) **Foreign Application Priority Data**

May 2, 2006 (JP) 2006-011515
Sep. 5, 2006 (JP) 2006-023699

(51) **LOC (8) Cl.** **13-03**

(52) **U.S. Cl.** **D13/147; D13/133; D13/154**

(58) **Field of Classification Search** D13/133, D13/146-147, 154, 184; D14/356, 433; 439/607-610, 660, 680, 686; 463/46, 47
See application file for complete search history.

(56) **References Cited**

U.S. PATENT DOCUMENTS

D333,293 S 2/1993 Ashida
D378,209 S * 2/1997 Morikawa et al. D13/147
D381,628 S 7/1997 Ashida
D381,977 S 8/1997 Nagata et al.
D391,551 S * 3/1998 Ono D13/147
D429,484 S * 8/2000 Nishio et al. D13/147

D453,320 S 2/2002 Sugino
D453,498 S 2/2002 Fujita
D454,837 S 3/2002 Ibuki et al.
D455,403 S 4/2002 Yoneyama et al.
D456,008 S 4/2002 Kawanobe et al.
D468,692 S 1/2003 Ashida et al.
D475,018 S 5/2003 Ashida et al.
D486,794 S * 2/2004 Okamoto D13/147
D507,533 S 7/2005 Yoneyama et al.
D518,437 S 4/2006 Yoneyama et al.
D520,453 S 5/2006 Yoneyama et al.
D527,347 S * 8/2006 Shang Yen et al. D13/147
D533,503 S 12/2006 Ashida et al.
D535,617 S 1/2007 Yoneyama et al.
D543,945 S * 6/2007 Ho et al. D13/147
D551,626 S * 9/2007 Ho et al. D13/147
D552,547 S * 10/2007 Nishio et al. D13/133

OTHER PUBLICATIONS

Ashida et al., entitled, "Connector Plug for Electronic Game Machine," U.S. Appl. No. 29/271,697, filed Jan. 25, 2007, pending.

(Continued)

Primary Examiner—Daniel Bui

(74) *Attorney, Agent, or Firm*—Nixon & Vanderhye, PC

(57) **CLAIM**

The ornamental design for a connector plug for electronic game machine, as shown and described.

DESCRIPTION

FIG. 1 is a front, top and right perspective view of a connector plug for electronic game machine showing a second embodiment our new design;

FIG. 2 is a rear, bottom and left perspective view thereof;

FIG. 3 is a front view thereof;

FIG. 4 is a rear view thereof;

FIG. 5 is a top plan view thereof;

FIG. 6 is a bottom plan view thereof; and,

FIG. 7 is a right side view thereof, a left side view being a mirror image thereof.

1 Claim, 2 Drawing Sheets

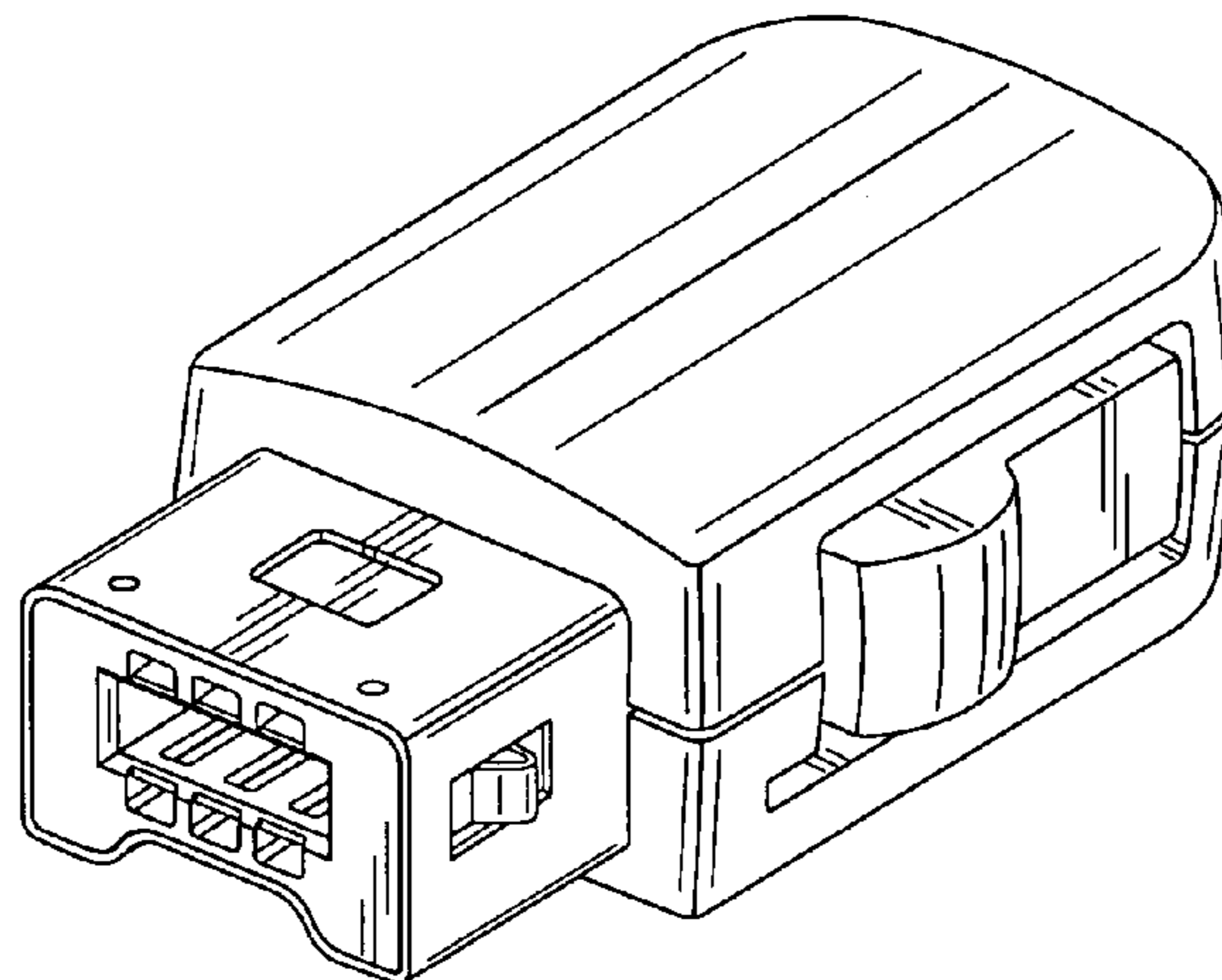

OTHER PUBLICATIONS

Kawanobe, entitled, "Connector Plug," U.S. Appl. No. 29/270,361, filed Dec. 21, 2006, pending.

Ashida et al., entitled, "Cable Connector Plug," U.S. Appl. No. 29/268,253, filed Nov. 2, 2006, pending.

Ashida et al., entitled, "Cable Connector Plug," U.S. Appl. No. 29/268,258, filed Nov. 2, 2006, pending.

Kawanobe, entitled, "A Cable Connector Plug for Hand-Held Electronic Game Machine," U.S. Appl. No. 29/242,561, filed Nov. 14, 2005, pending.

Fujino, entitled, "Connector Plug for Electronic Game Machine," U.S. Appl. No. 29/263,345, filed Jul. 21, 2006, pending.

Ashida et al., entitled, "Cable Connector Plug," U.S. Appl. No. 29/268,257, filed Nov. 2, 2006, pending.

Ashida et al., entitled, "Connector Plug for Electronic Game Machine," U.S. Appl. No. 29/271,697, filed Jan. 25, 2007, pending.

Kawanobe., entitled, "Connector Plug," U.S. Appl. No. 29/270,361, filed Dec. 21, 2006, pending.

* cited by examiner

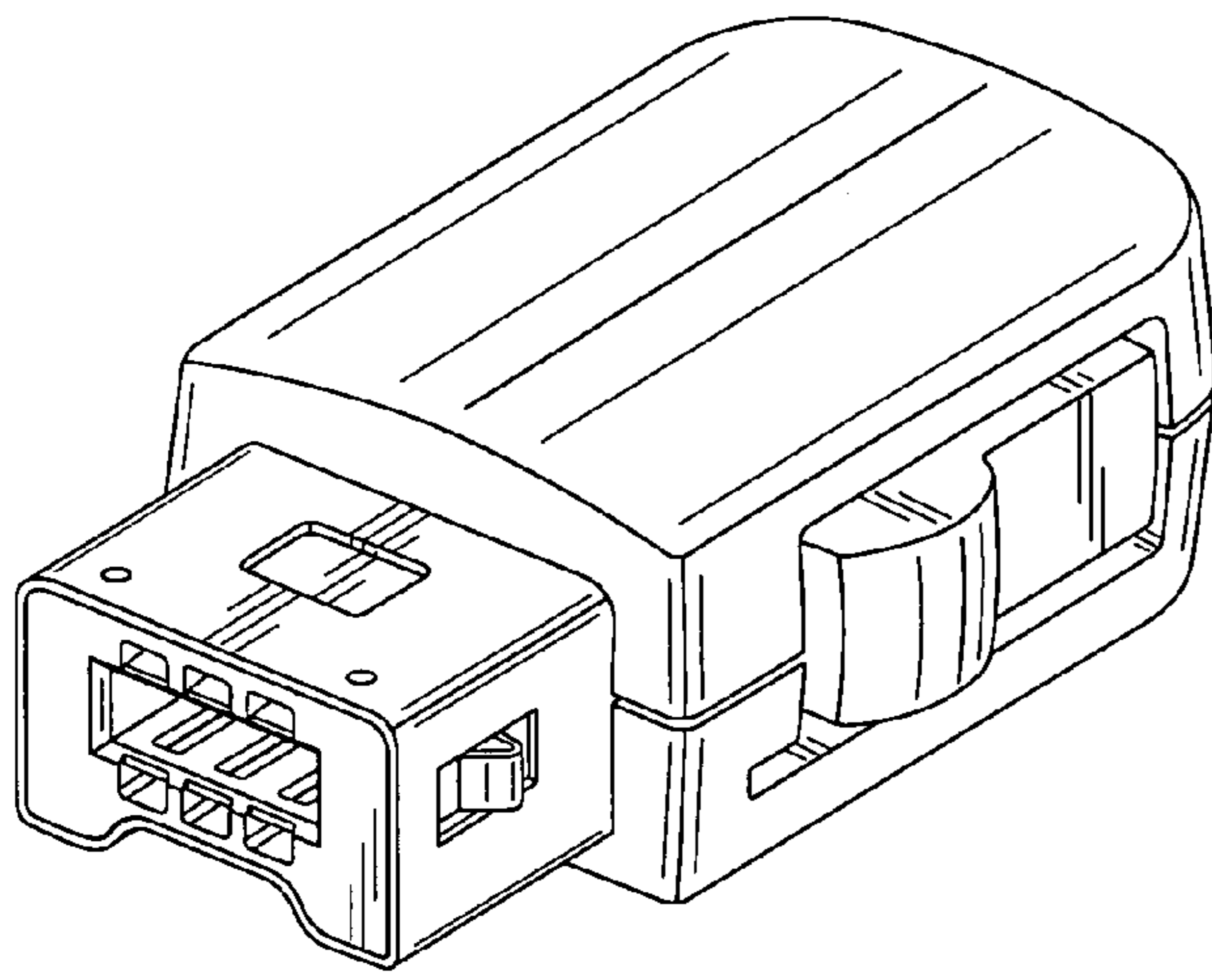

FIG. 1

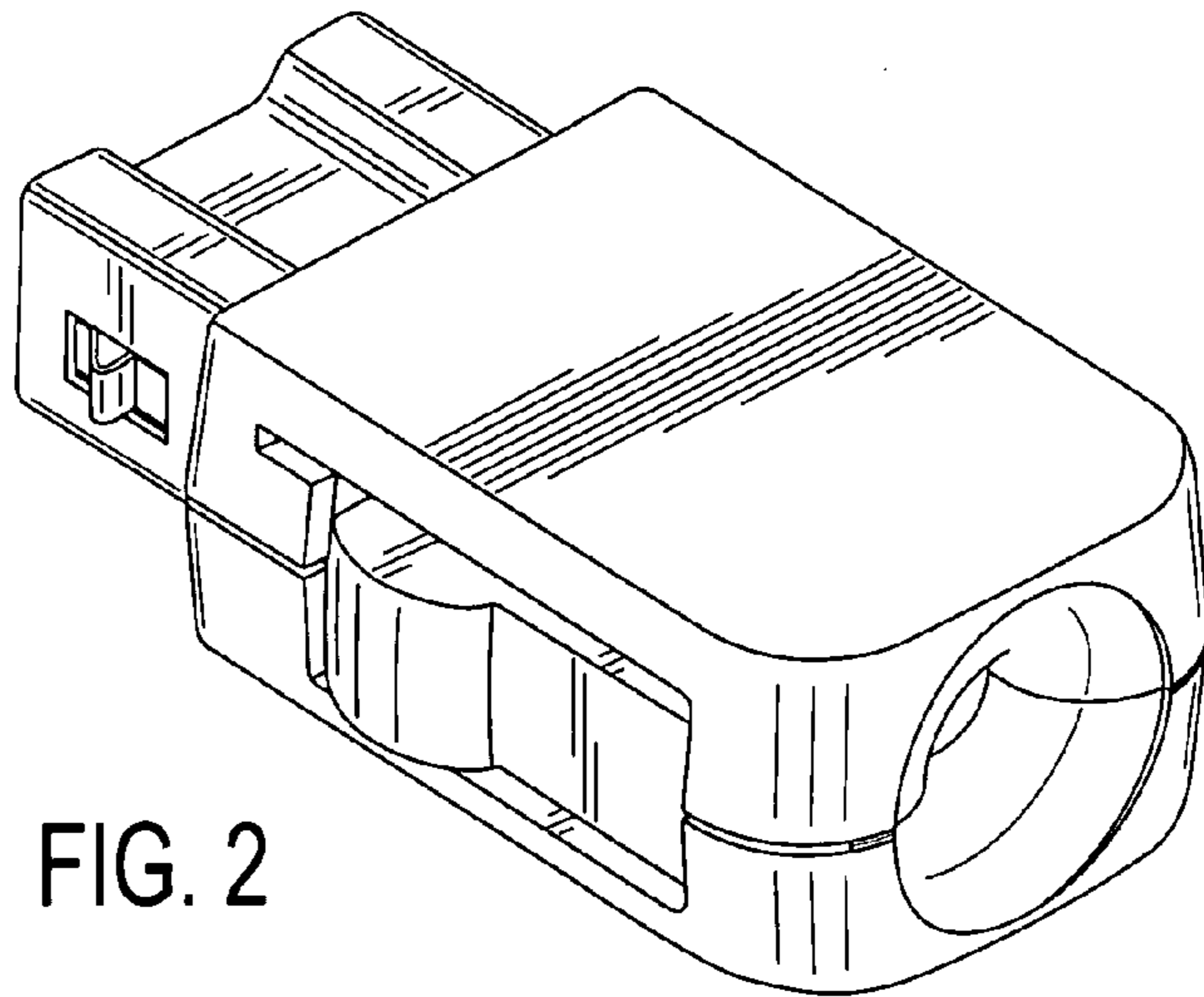

FIG. 2

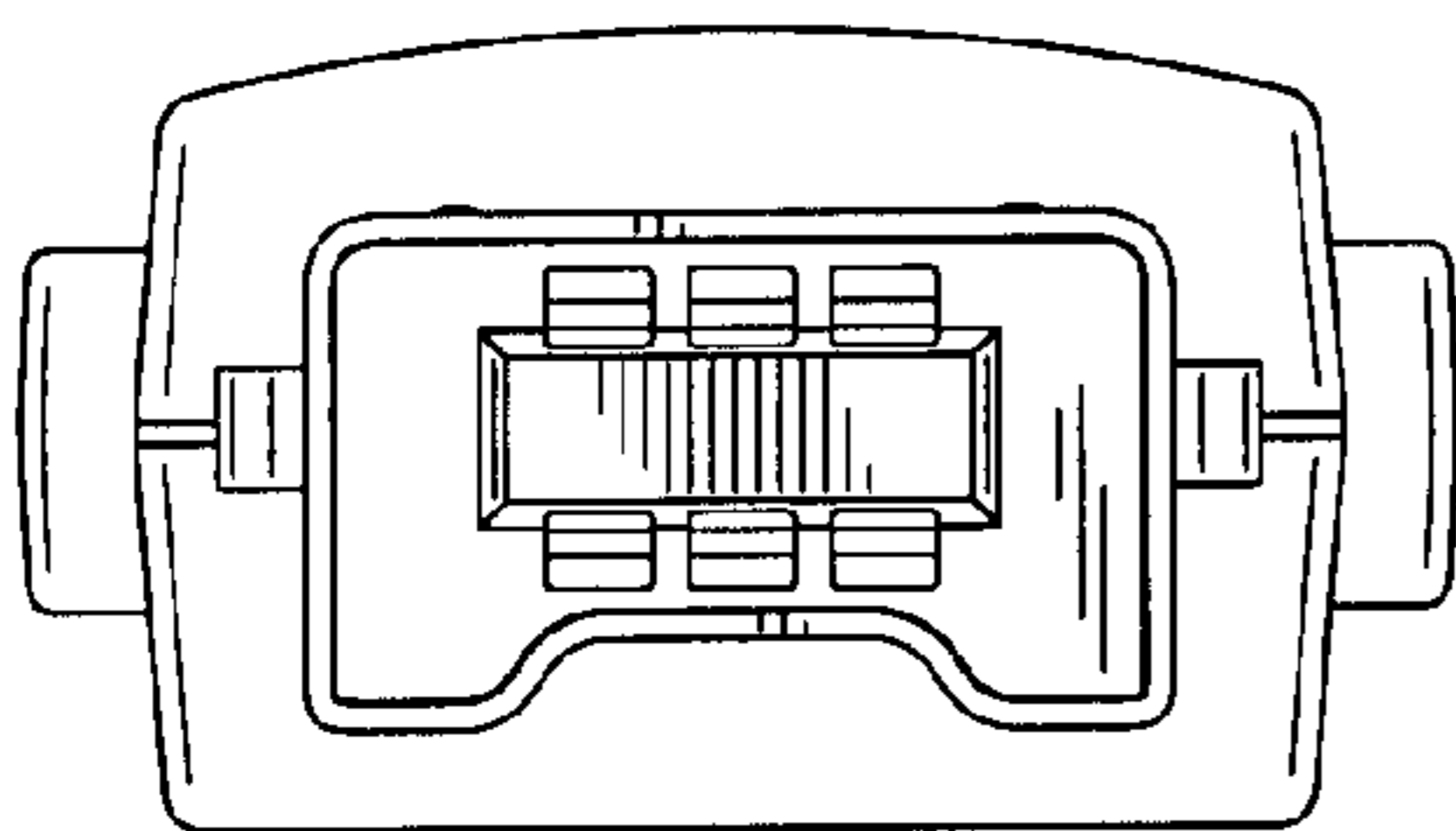

FIG. 3

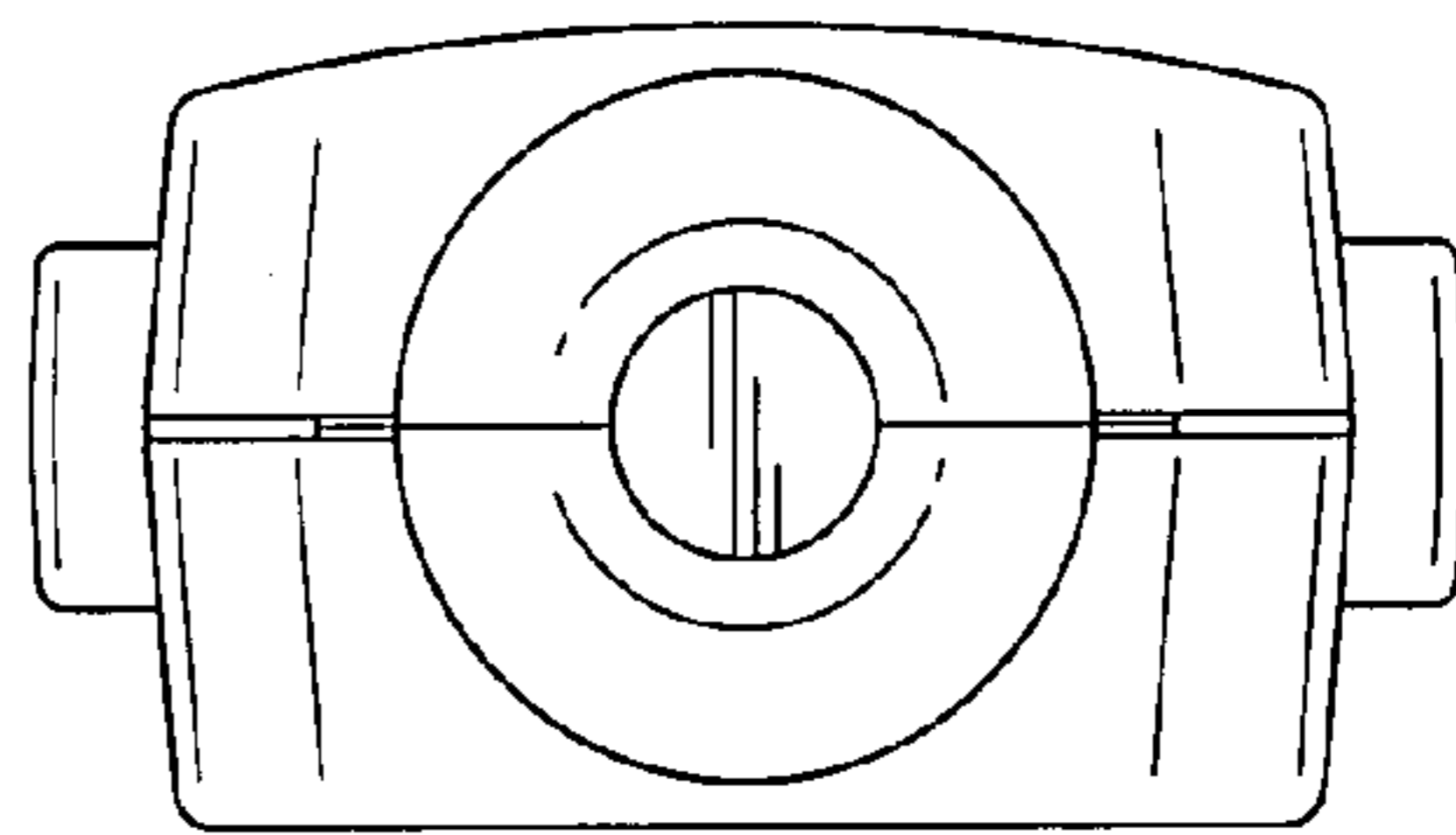

FIG. 4

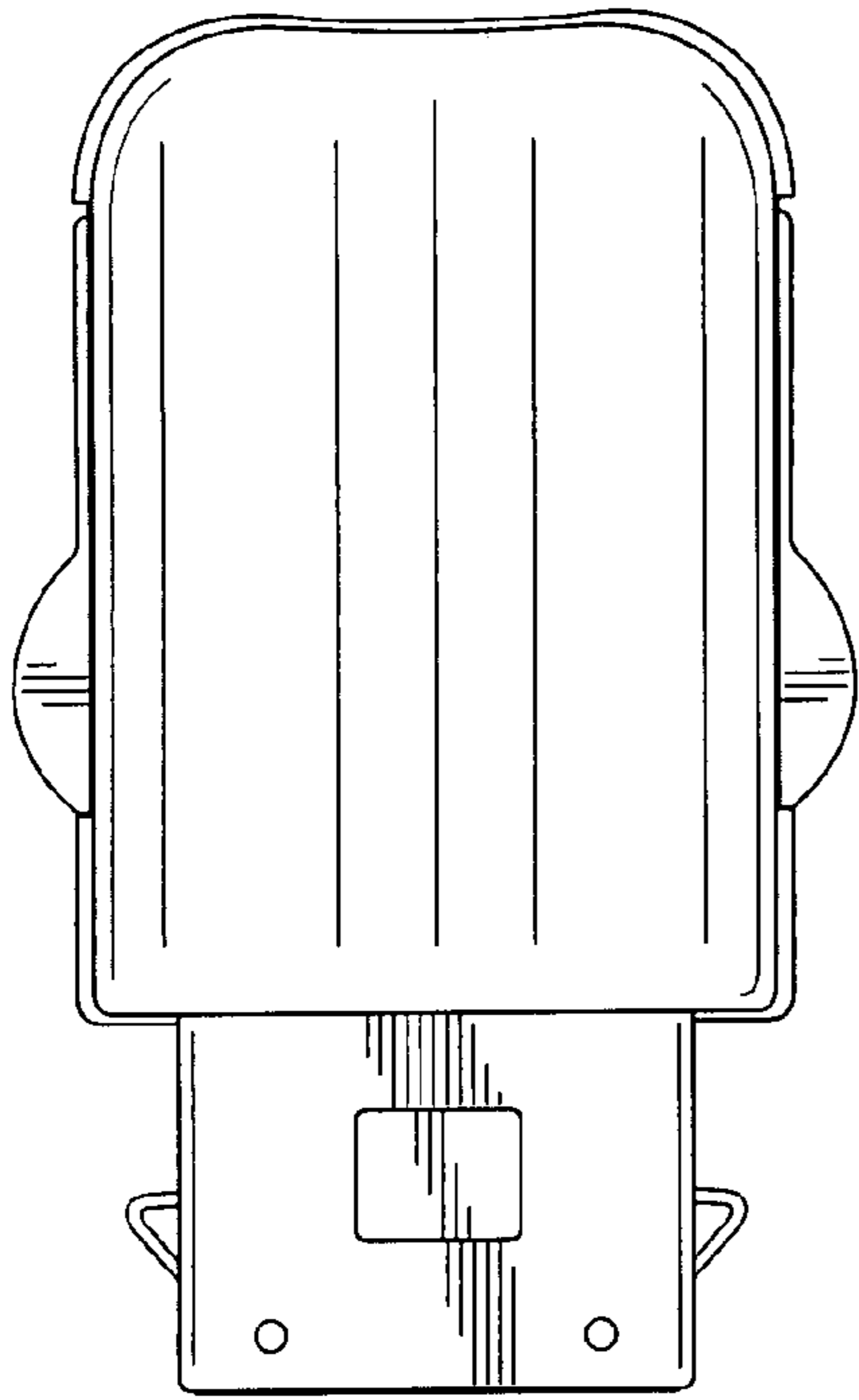

FIG. 5

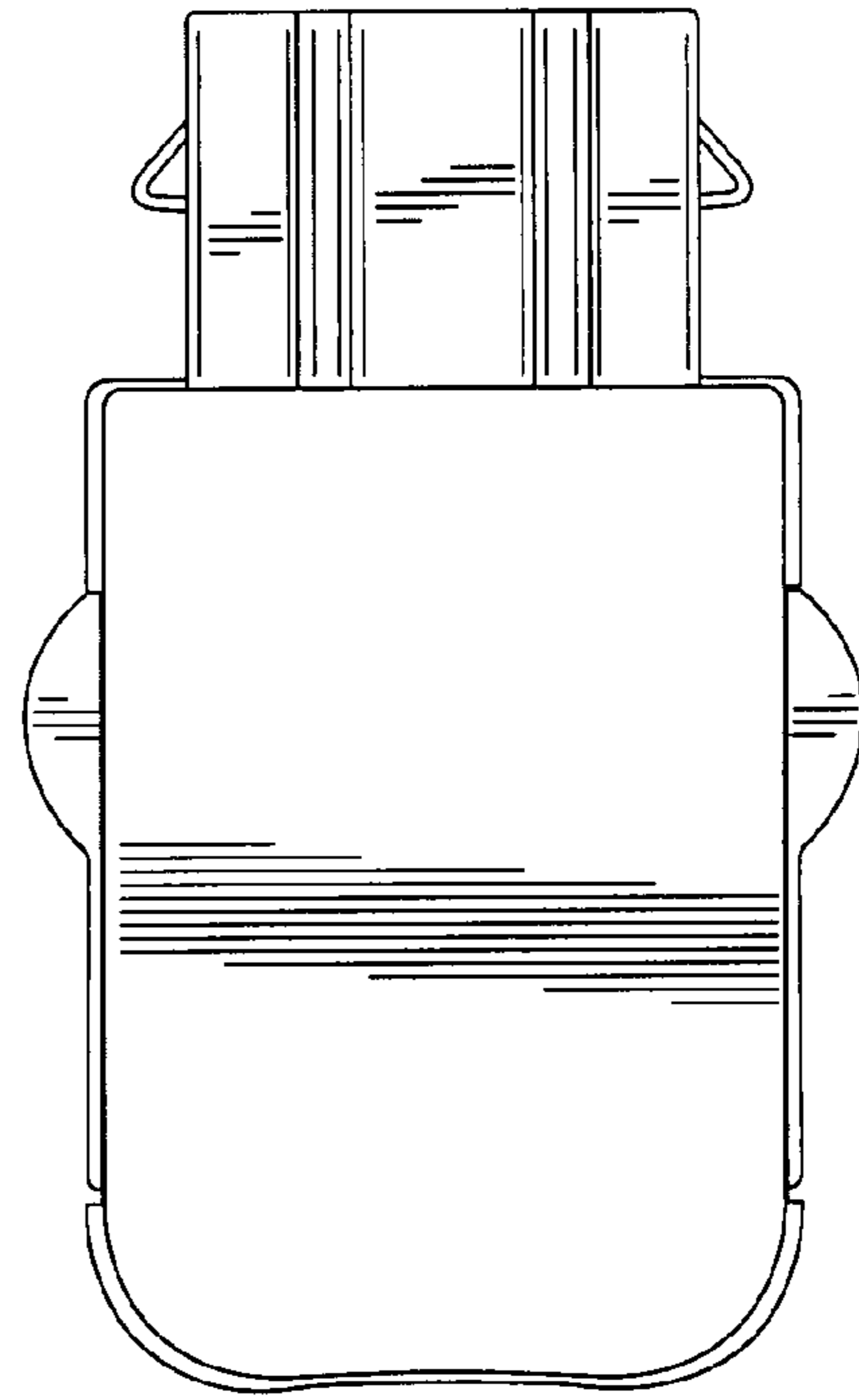

FIG. 6

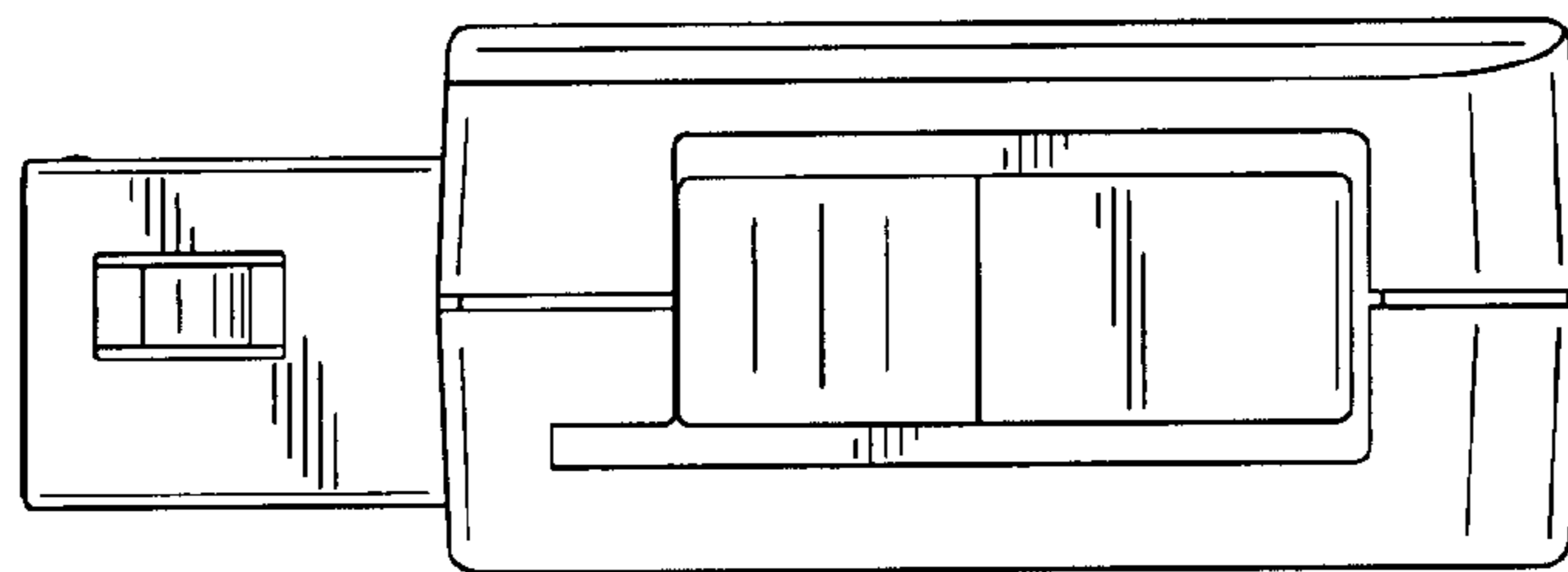

FIG. 7