



US00D568803S

(12) **United States Design Patent**
Rypinski

(10) **Patent No.:** **US D568,803 S**

(45) **Date of Patent:** **** May 13, 2008**

(54) **MOTOR SAILOR**

(76) **Inventor:** **Donald Rypinski**, 629 Terminal Way,
Unit 3, Costa Mesa, CA (US) 92627

(**) **Term:** **14 Years**

(21) **Appl. No.:** **29/271,807**

(22) **Filed:** **Jan. 26, 2007**

(51) **LOC (8) Cl.** **12-06**

(52) **U.S. Cl.** **D12/304**

(58) **Field of Classification Search** D12/300,
D12/302, 303, 310–313, 317; 114/39.11–39.15,
114/39.21–39.32, 61.1, 61.24, 61.23
See application file for complete search history.

(56) **References Cited**

U.S. PATENT DOCUMENTS

D249,137 S *	8/1978	Hoyt	D12/300
D292,908 S *	11/1987	Moar	D12/300
5,529,008 A *	6/1996	Craig	114/61.1
D486,118 S *	2/2004	Rypinski	D12/300
2004/0261678 A1 *	12/2004	Morelock et al.	114/39.26

* cited by examiner

Primary Examiner—Holly H. Baynham

Assistant Examiner—Cynthia M. Chin

(74) *Attorney, Agent, or Firm*—Walter A. Hackler

(57) **CLAIM**

The ornamental design for a motor sailor, as shown and described.

DESCRIPTION

FIG. 1 is a perspective view of the present invention;
FIG. 2 is a top view of the present invention;
FIG. 3 is a side view of the present invention, the opposite side being identical;
FIG. 4 is a front view of the present invention;
FIG. 5 is a rear view of the present invention; and,
FIG. 6 is a bottom view of the present invention.

The broken lines are for illustrative purposes only and form no part of the claimed design. Portions of FIGS. 3–5 have been shown broken away for ease and clarity of illustration.

1 Claim, 4 Drawing Sheets

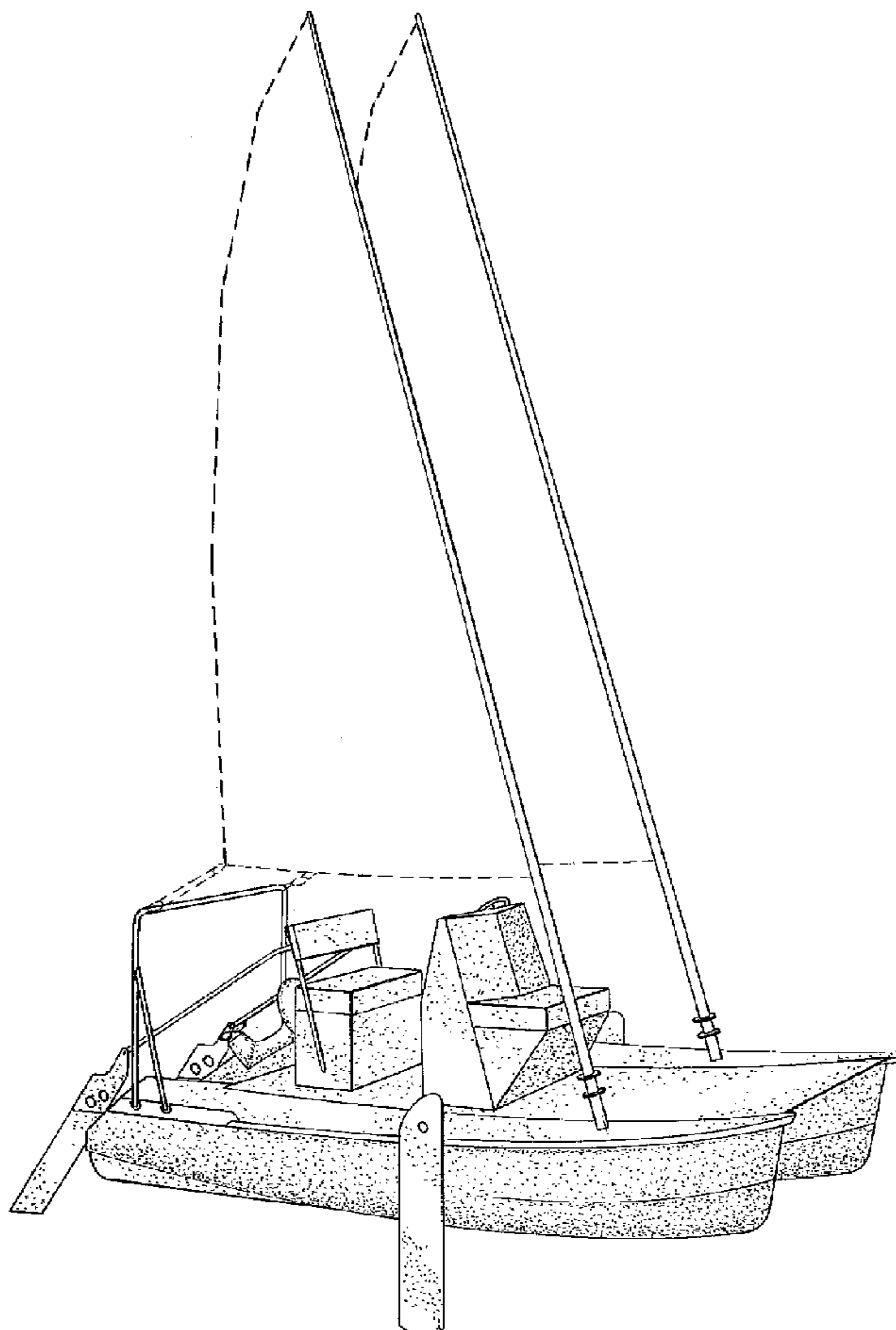

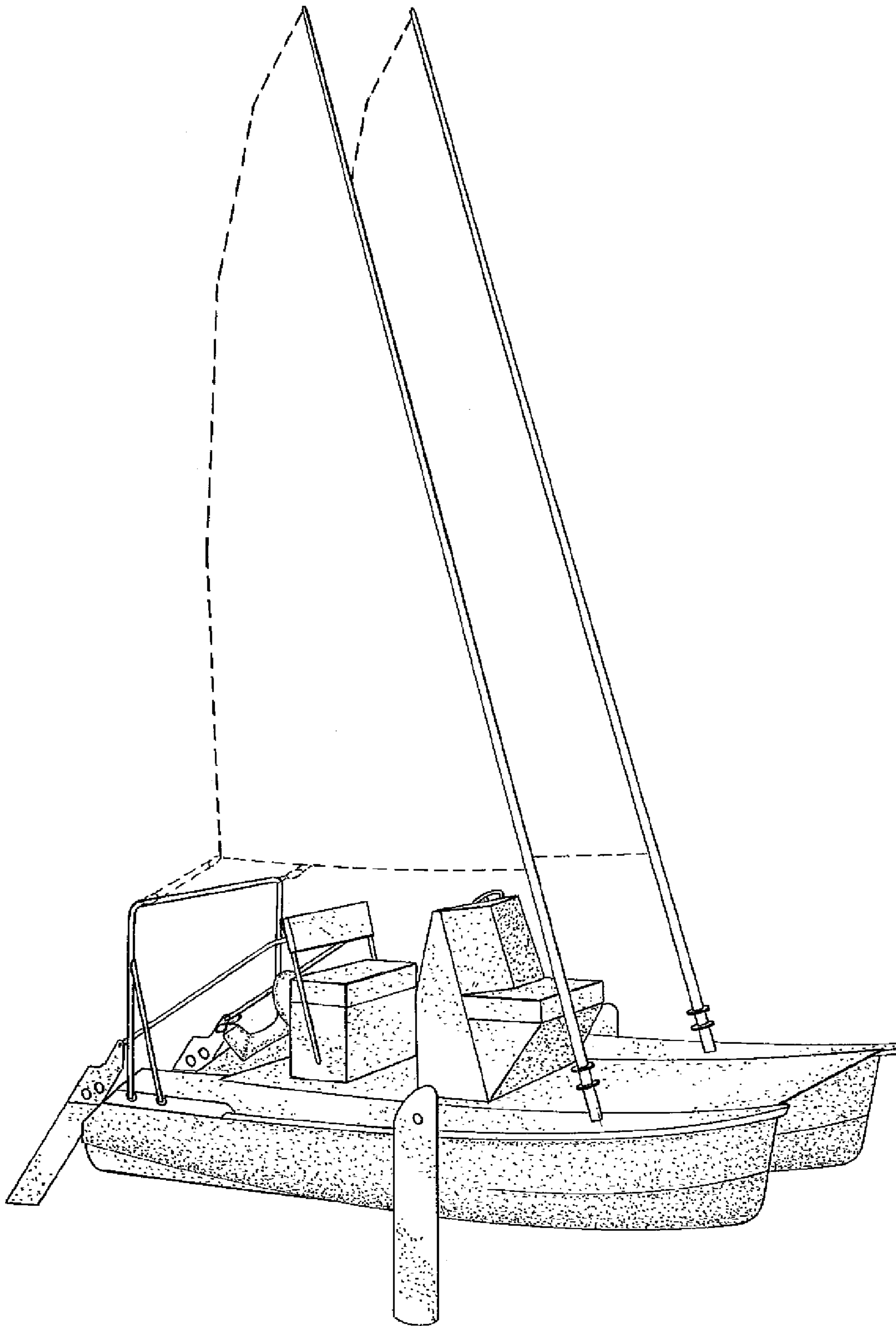

FIG. 1.

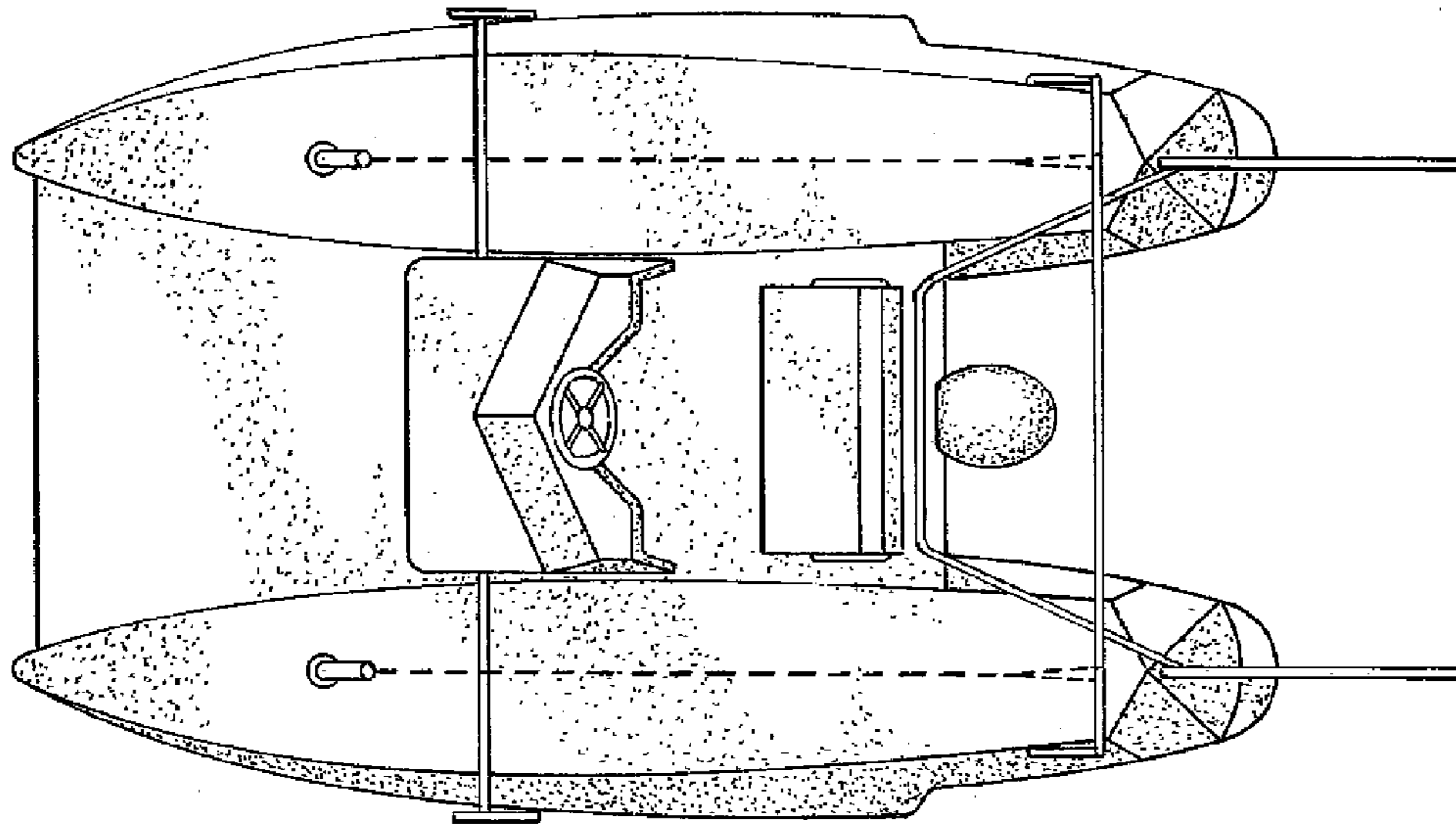

FIG. 2.

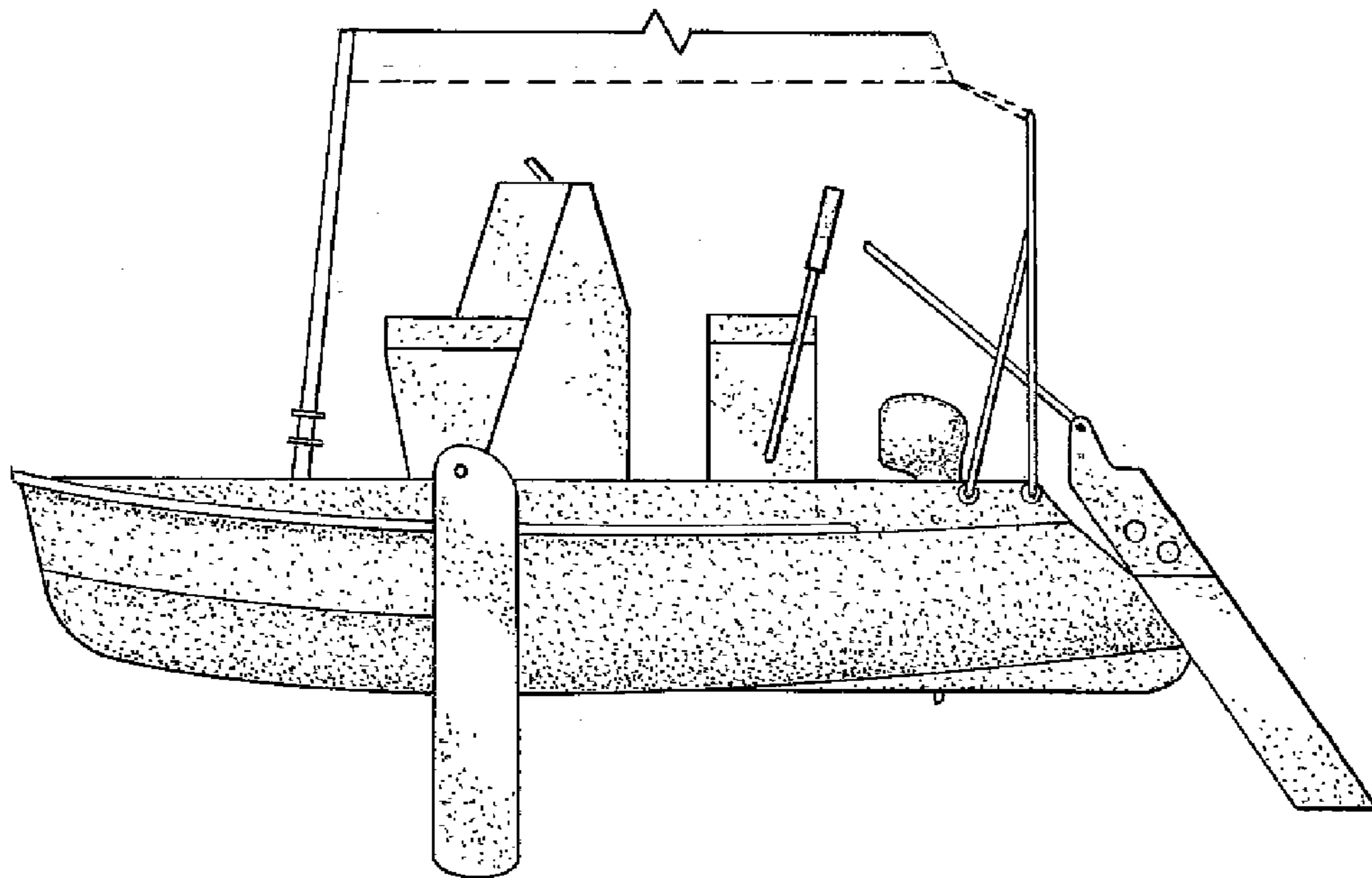

FIG. 3.

FIG. 4.

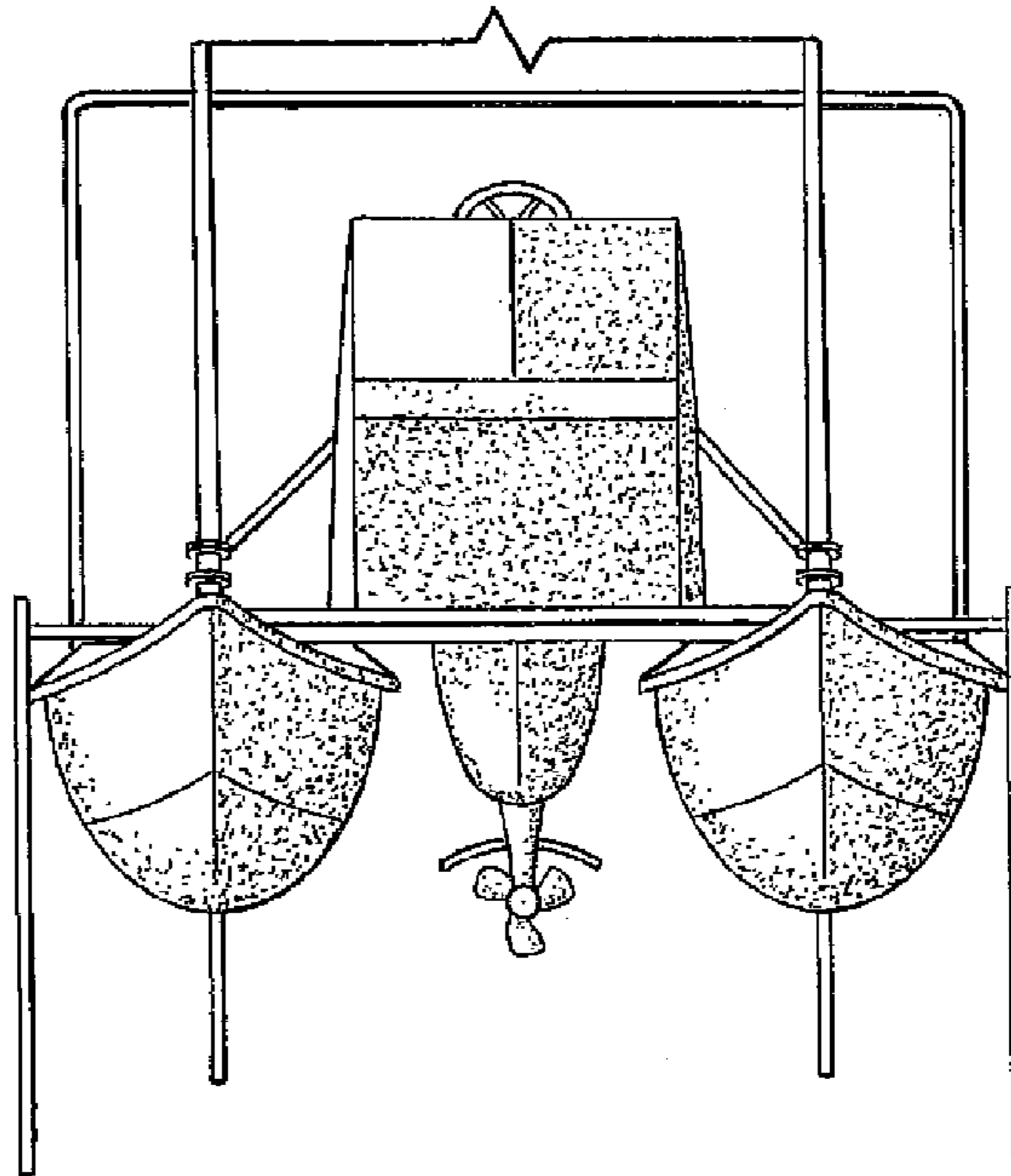
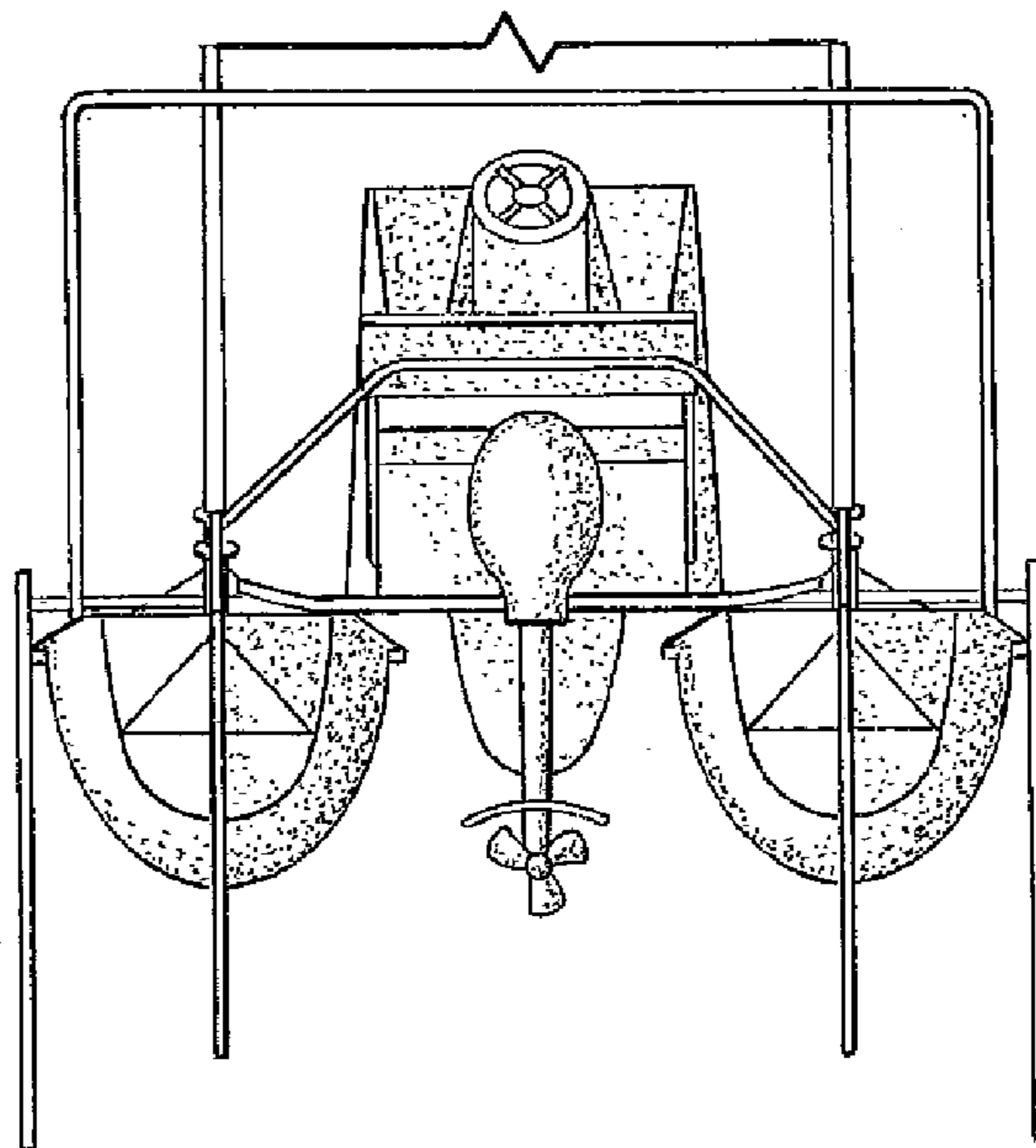

FIG. 5.



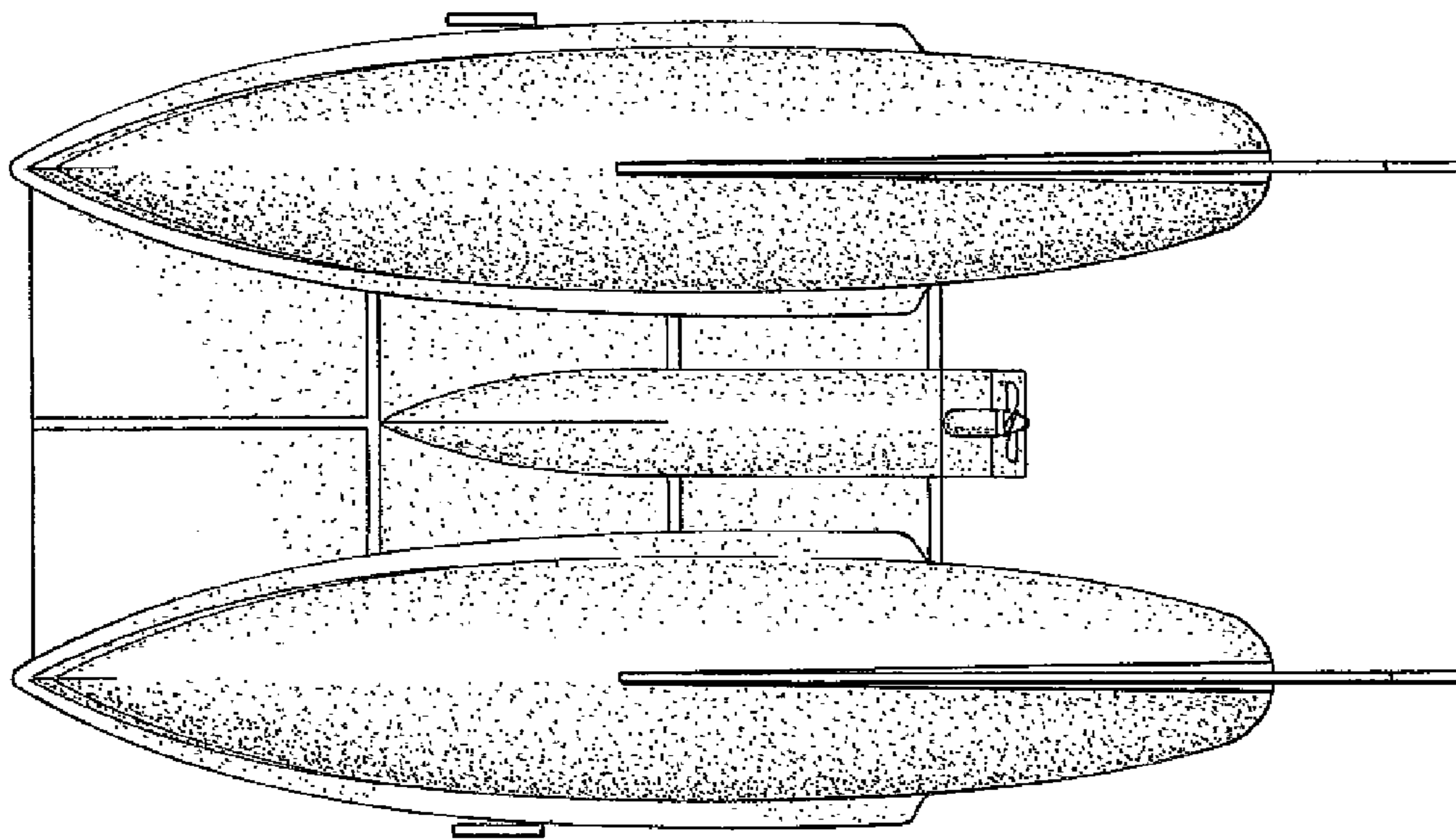

FIG. 6.