

US00D568800S

(12) **United States Design Patent**  
**Huet**

(10) **Patent No.: US D568,800 S**

(45) **Date of Patent: \*\* May 13, 2008**

(54) **FRONT FACE OF A VEHICLE WHEEL**

(75) **Inventor: Jean-François Alexandre Huet, Villers  
Allerand (FR)**

(73) **Assignee: Bayerische Motoren Werke  
Aktiengesellschaft, Munich (DE)**

(\*\*) **Term: 14 Years**

(21) **Appl. No.: 29/283,807**

(22) **Filed: Aug. 24, 2007**

(30) **Foreign Application Priority Data**

Feb. 26, 2007 (DE) ..... 4 07 01 059

(51) **LOC (8) Cl. .... 12-16**

(52) **U.S. Cl. .... D12/211**

(58) **Field of Classification Search ..... D12/204-213;  
301/37.101, 64.101, 65, 64.201**  
See application file for complete search history.

(56) **References Cited**

**U.S. PATENT DOCUMENTS**

- D409,552 S \* 5/1999 Chung ..... D12/211
- D447,993 S \* 9/2001 Neeper ..... D12/211
- D451,463 S \* 12/2001 Murkett et al. .... D12/209
- D456,333 S \* 4/2002 Pollmann ..... D12/211
- D466,854 S \* 12/2002 Kern ..... D12/211

- D475,337 S \* 6/2003 Kataoka ..... D12/209
- D494,917 S \* 8/2004 Pollmann ..... D12/211
- D499,371 S \* 12/2004 Koch ..... D12/211
- D506,719 S \* 6/2005 Chen ..... D12/211
- D513,727 S \* 1/2006 Gallert ..... D12/211
- D528,959 S 9/2006 Sycha
- D531,560 S \* 11/2006 Looho ..... D12/209
- D535,241 S \* 1/2007 Kim ..... D12/211

\* cited by examiner

*Primary Examiner*—Stacia Cadmus

(74) *Attorney, Agent, or Firm*—Crowell & Moring LLP

(57) **CLAIM**

The ornamental design for a front face of a vehicle wheel, as shown and described.

**DESCRIPTION**

This application is related to the following co-pending application: Application Ser. No. 29/284,592, filed Sep. 12, 2007, and entitled Front Face of a Vehicle Wheel.

FIG. 1 is a front view of a front face of a vehicle wheel according to my novel design; and,

FIG. 2 is a perspective view thereof.

The broken lines are for illustrative purposes only and form no part of the claimed design.

**1 Claim, 1 Drawing Sheet**

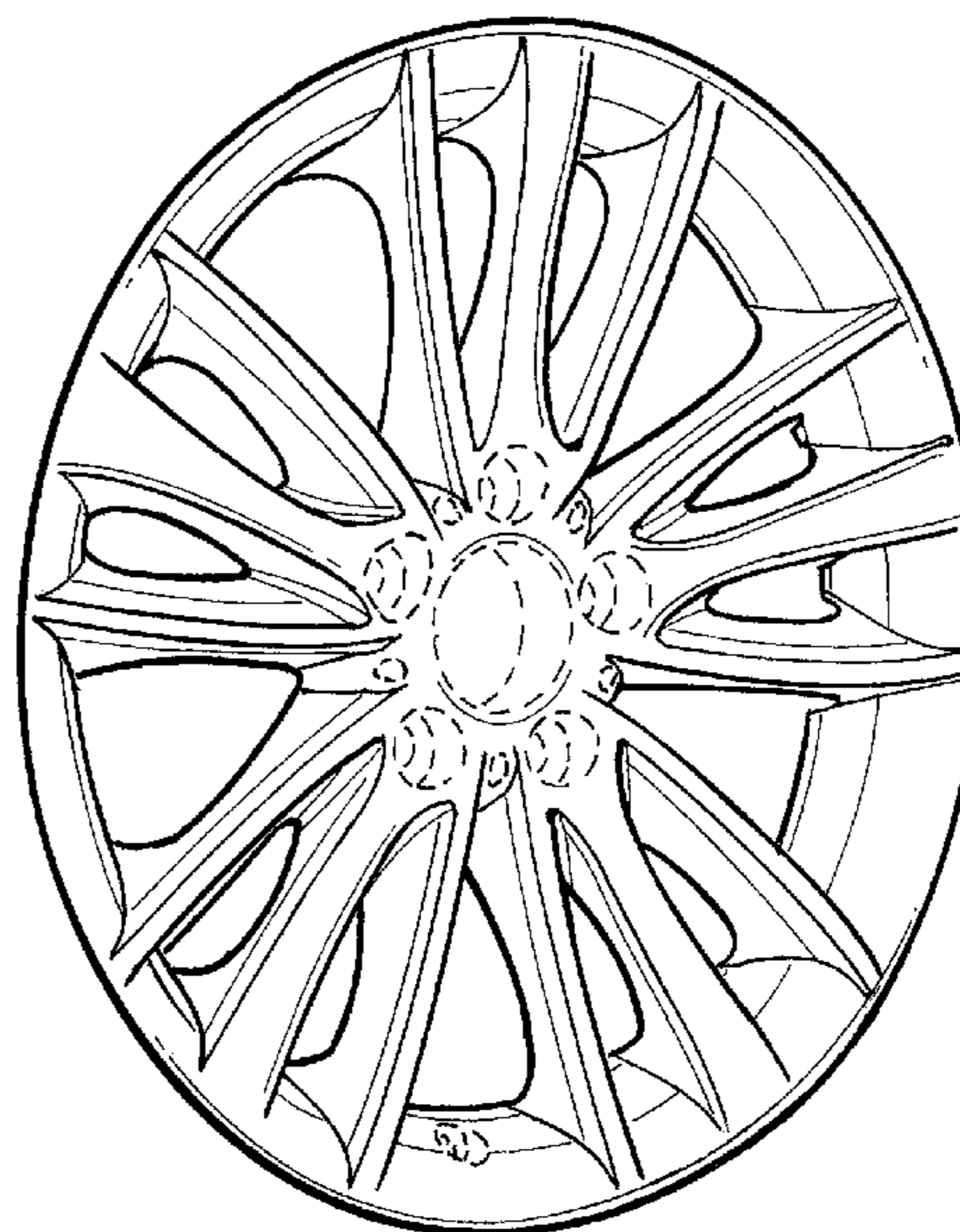
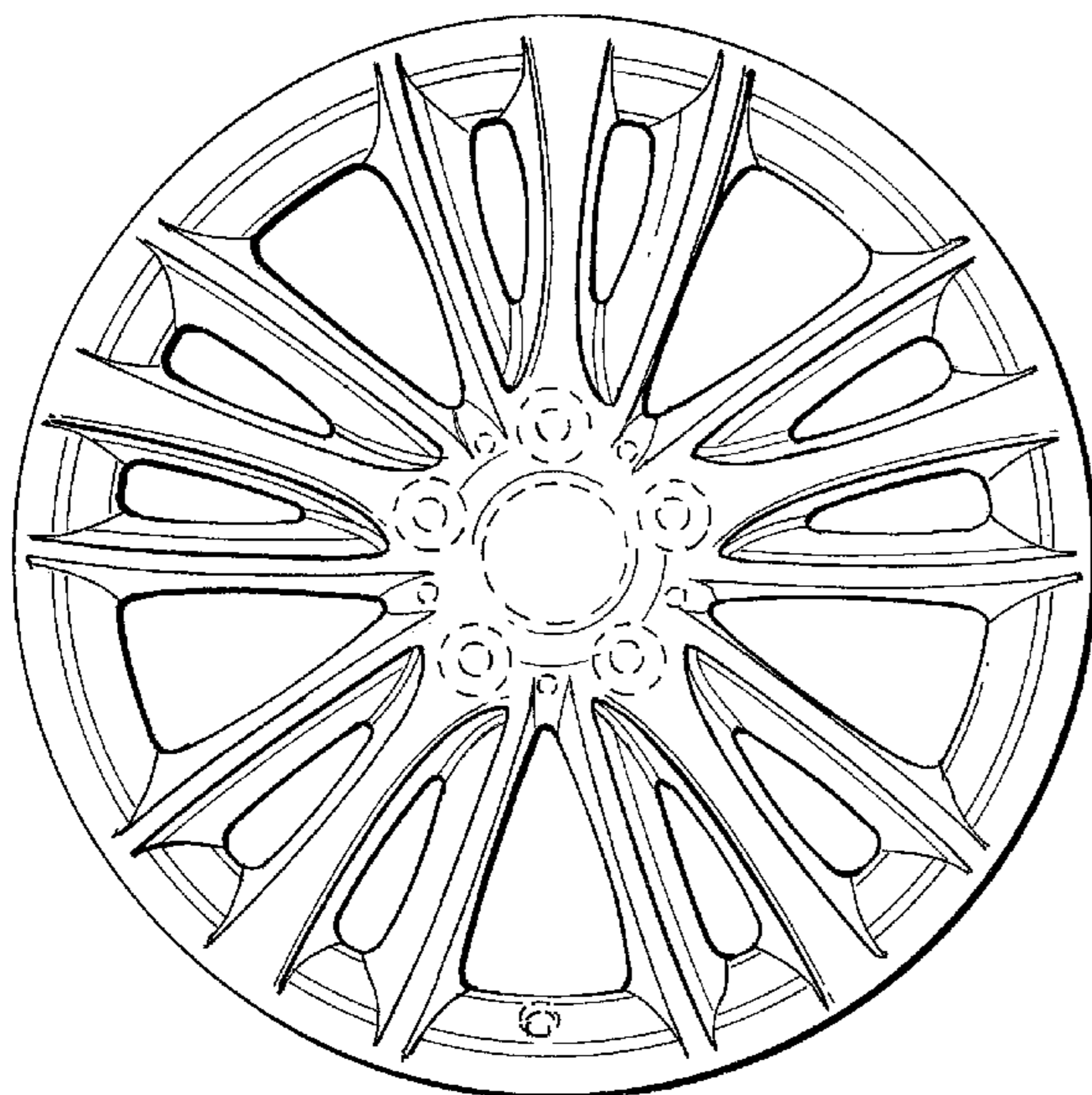

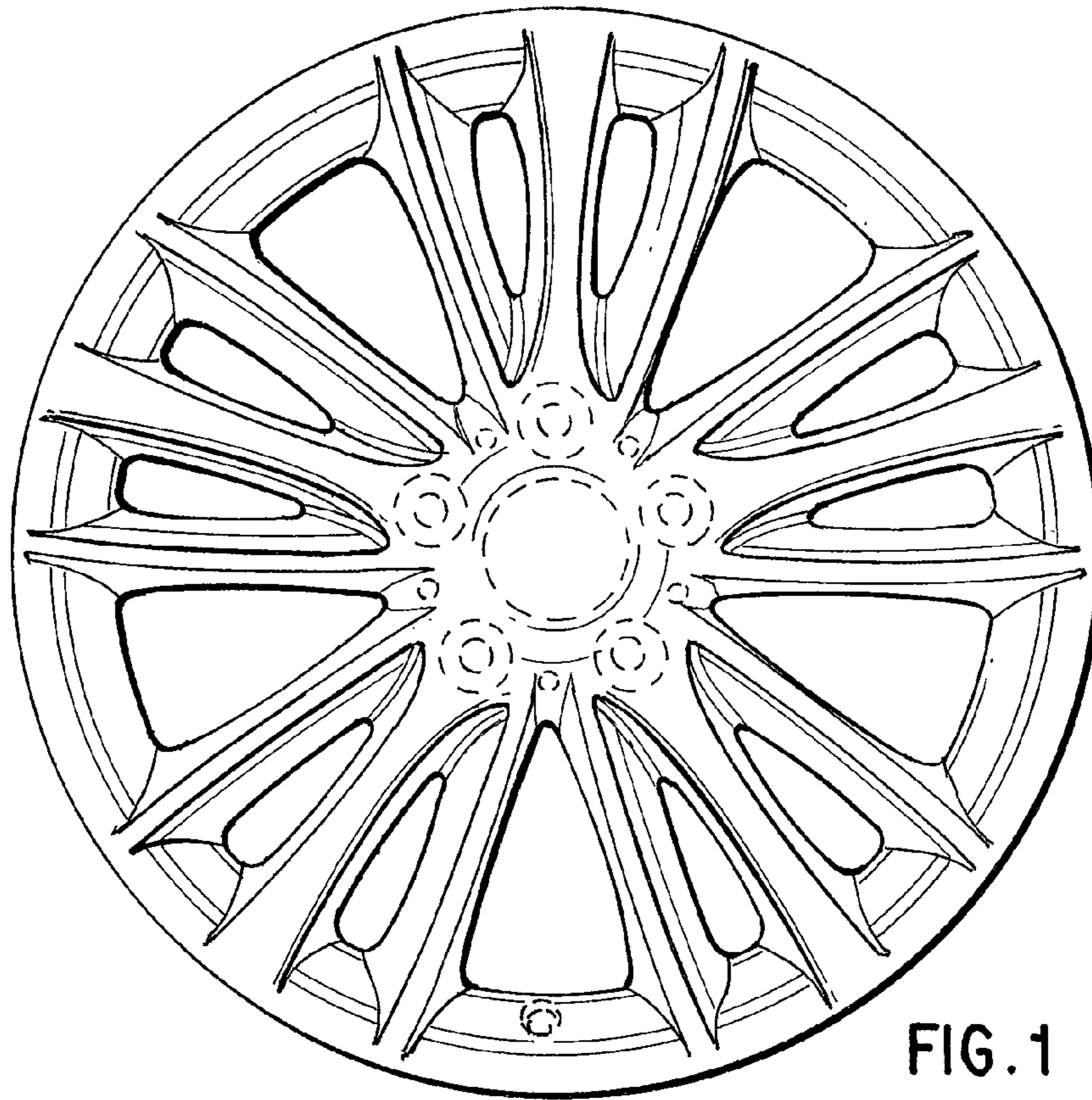

FIG. 1

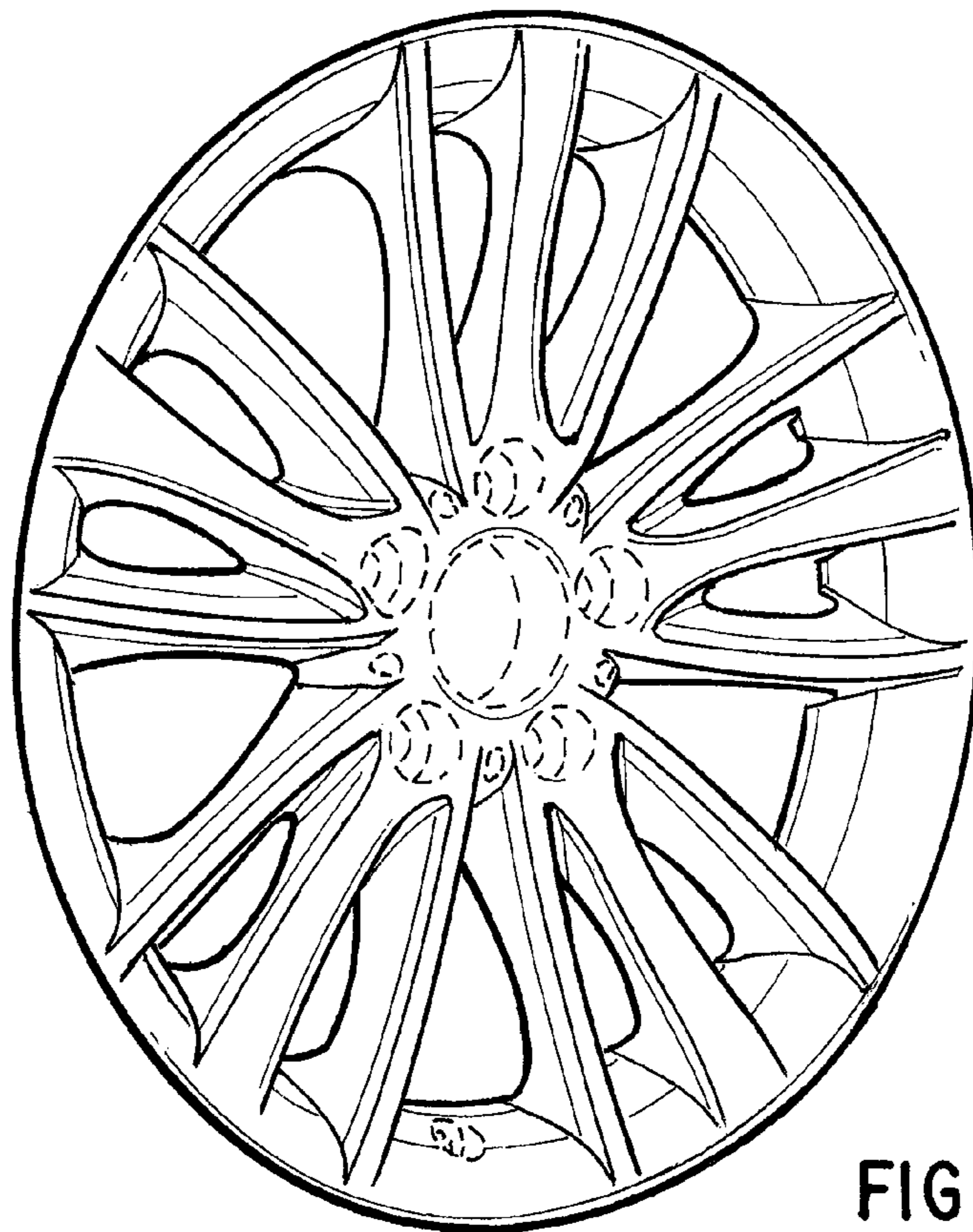

FIG. 2