



US00D568795S

(12) **United States Design Patent** (10) **Patent No.:** **US D568,795 S**
Mozer et al. (45) **Date of Patent:** **** May 13, 2008**

(54) **SWITCH LEVER FOR AN AUTOMOTIVE VEHICLE**

Primary Examiner—Sandra Snapp
(74) *Attorney, Agent, or Firm*—Osha Liang LLP

(75) Inventors: **Reiner Mozer**, Vaihingen/Enz (DE);
Joerg Weber, Bietigheim-Bissingen (DE)

(57) **CLAIM**

(73) Assignee: **Valeo Schalter und Sensoren GmbH**,
Bietigheim-Bissingen (DE)

The ornamental design for a switch lever for an automotive vehicle, as shown and described.

(**) Term: **14 Years**

(21) Appl. No.: **29/268,825**

DESCRIPTION

(22) Filed: **Nov. 13, 2006**

(30) **Foreign Application Priority Data**

May 12, 2006 (EM) 000533773-0001

(51) **LOC (8) Cl.** **12-16**

(52) **U.S. Cl.** **D12/174**

(58) **Field of Classification Search** D12/125,
D12/174-177, 179, 184-185, 400; 280/259;
74/490.14, 512, 563; 403/257; D8/303
See application file for complete search history.

FIG. 1 is a perspective view of a switch lever for an automotive vehicle according to an embodiment of the invention.

FIG. 2 is a front view of the switch lever for an automotive vehicle according to the embodiment of FIG. 1.

FIG. 3 is a back view of the switch lever for an automotive vehicle according to the embodiment of FIG. 1.

FIG. 4 is a left view of the switch lever for an automotive vehicle according to the embodiment of FIG. 1.

FIG. 5 is a right view of the switch lever for an automotive vehicle according to the embodiment of FIG. 1.

FIG. 6 is a top view of the switch lever for an automotive vehicle according to the embodiment of FIG. 1; and,

FIG. 7 is a bottom view of the switch lever for an automotive vehicle according to the embodiment of FIG. 1.

The portions in broken lines are for illustrative purposes only and form no part of the claimed design.

(56) **References Cited**

U.S. PATENT DOCUMENTS

- D192,866 S * 5/1962 Crenshaw D21/775
- D218,602 S * 9/1970 Malasky D12/179
- D256,575 S * 8/1980 Moore D12/174
- D294,243 S * 2/1988 Lane, Jr. D12/174
- D413,091 S * 8/1999 DuRocher et al. D12/174
- D519,354 S * 4/2006 Hay D8/303

FOREIGN PATENT DOCUMENTS

DE 20 2006 009 534 8/2006

* cited by examiner

1 Claim, 4 Drawing Sheets

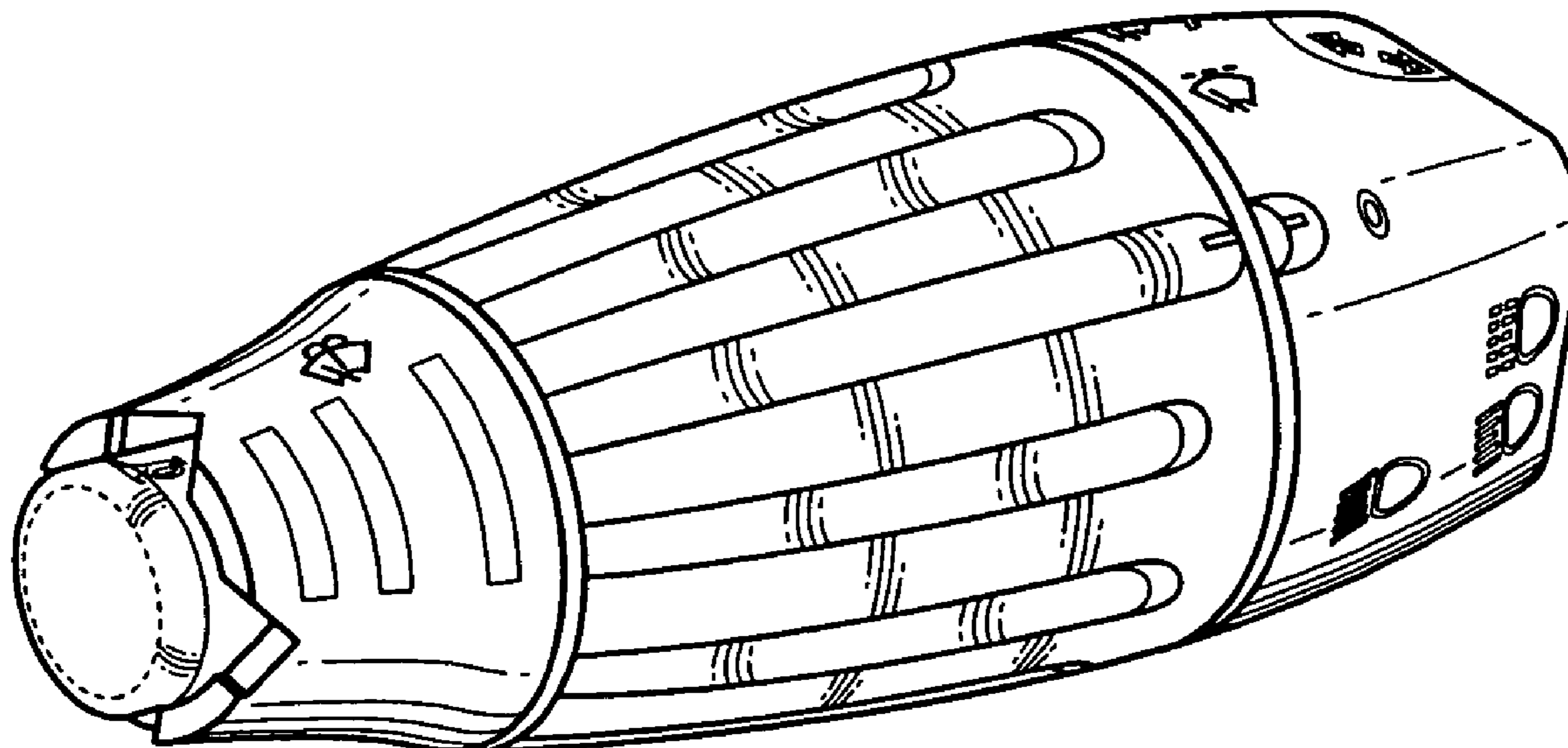

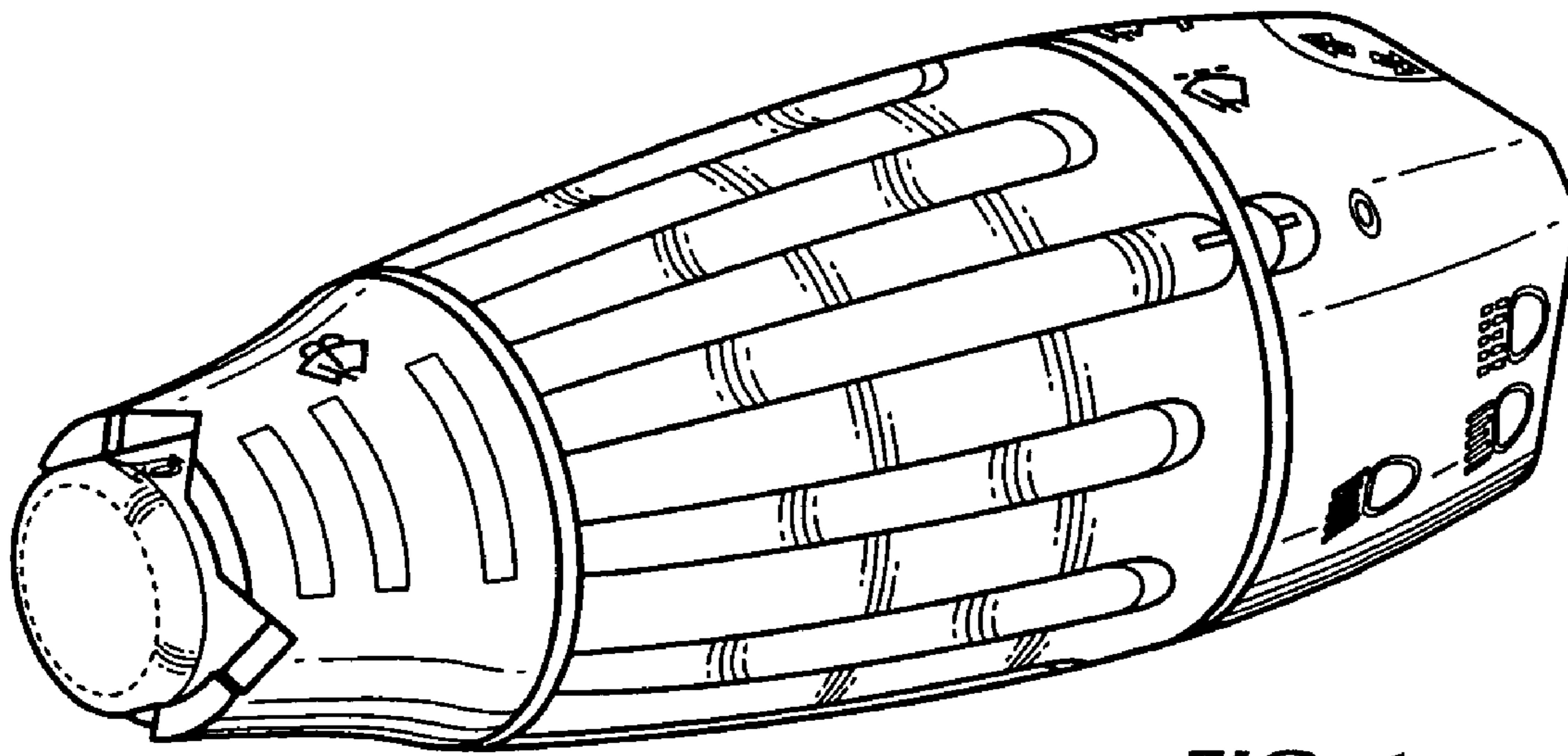

FIG. 1

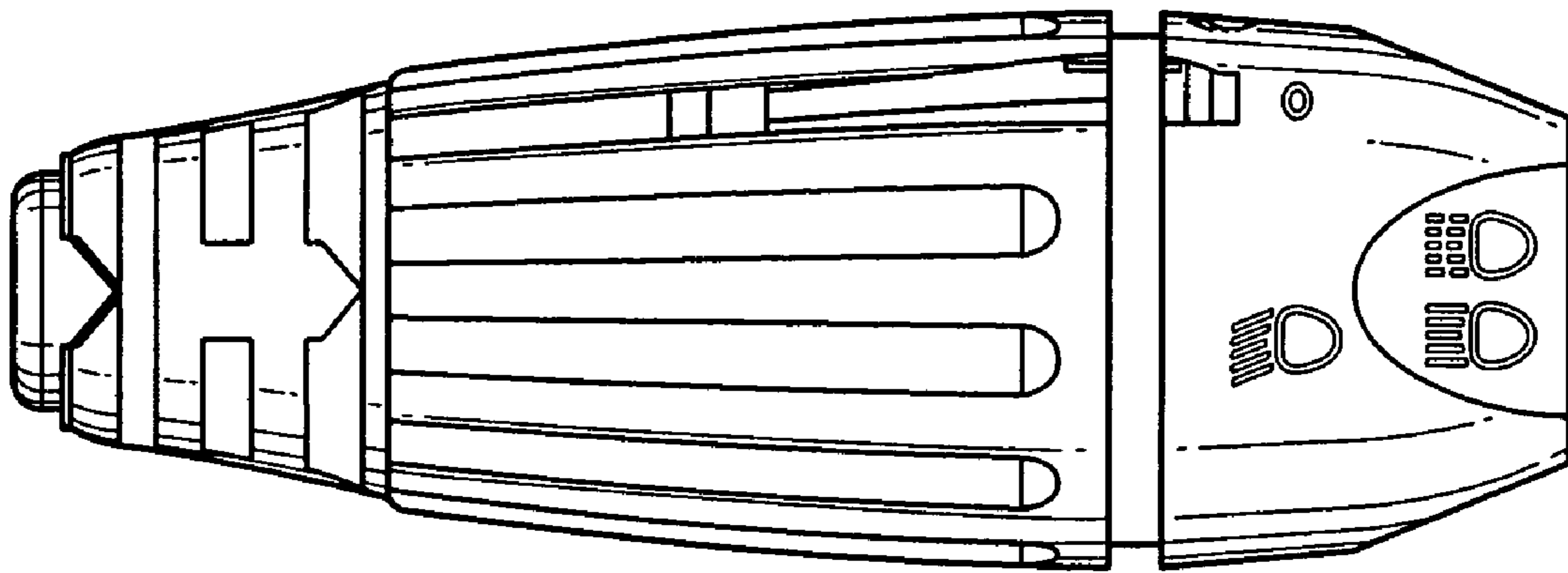

FIG. 2

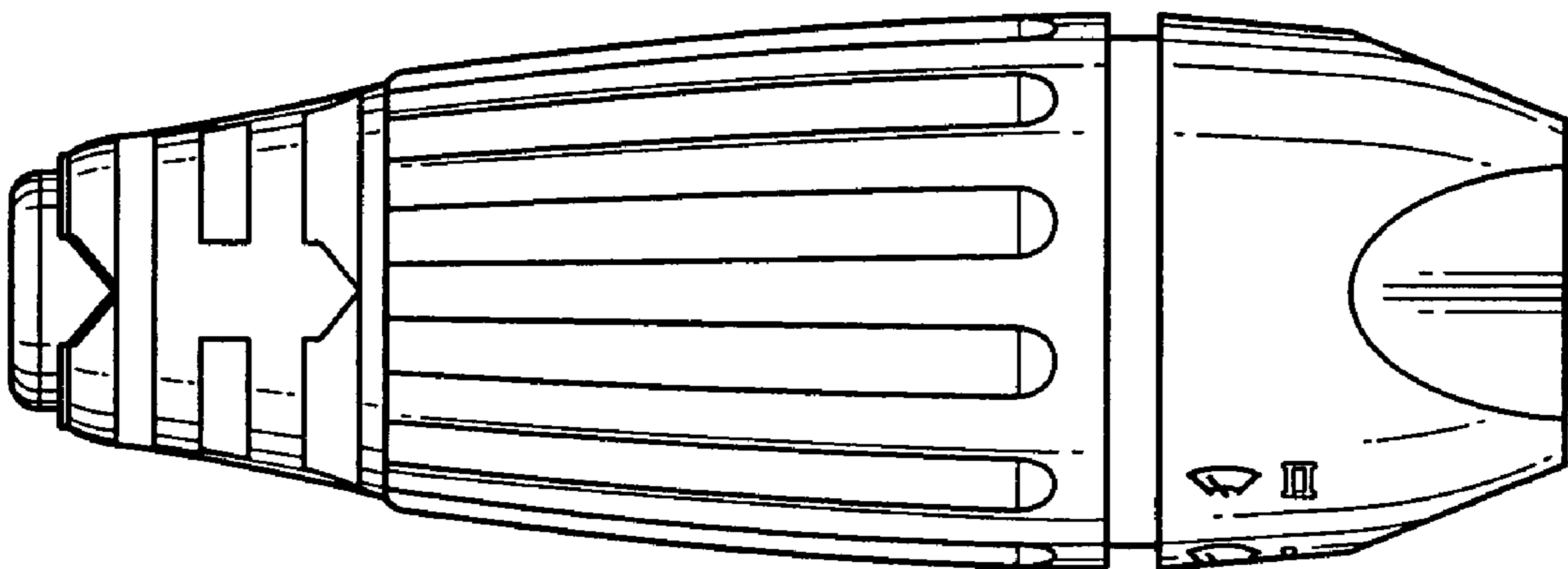

FIG. 3

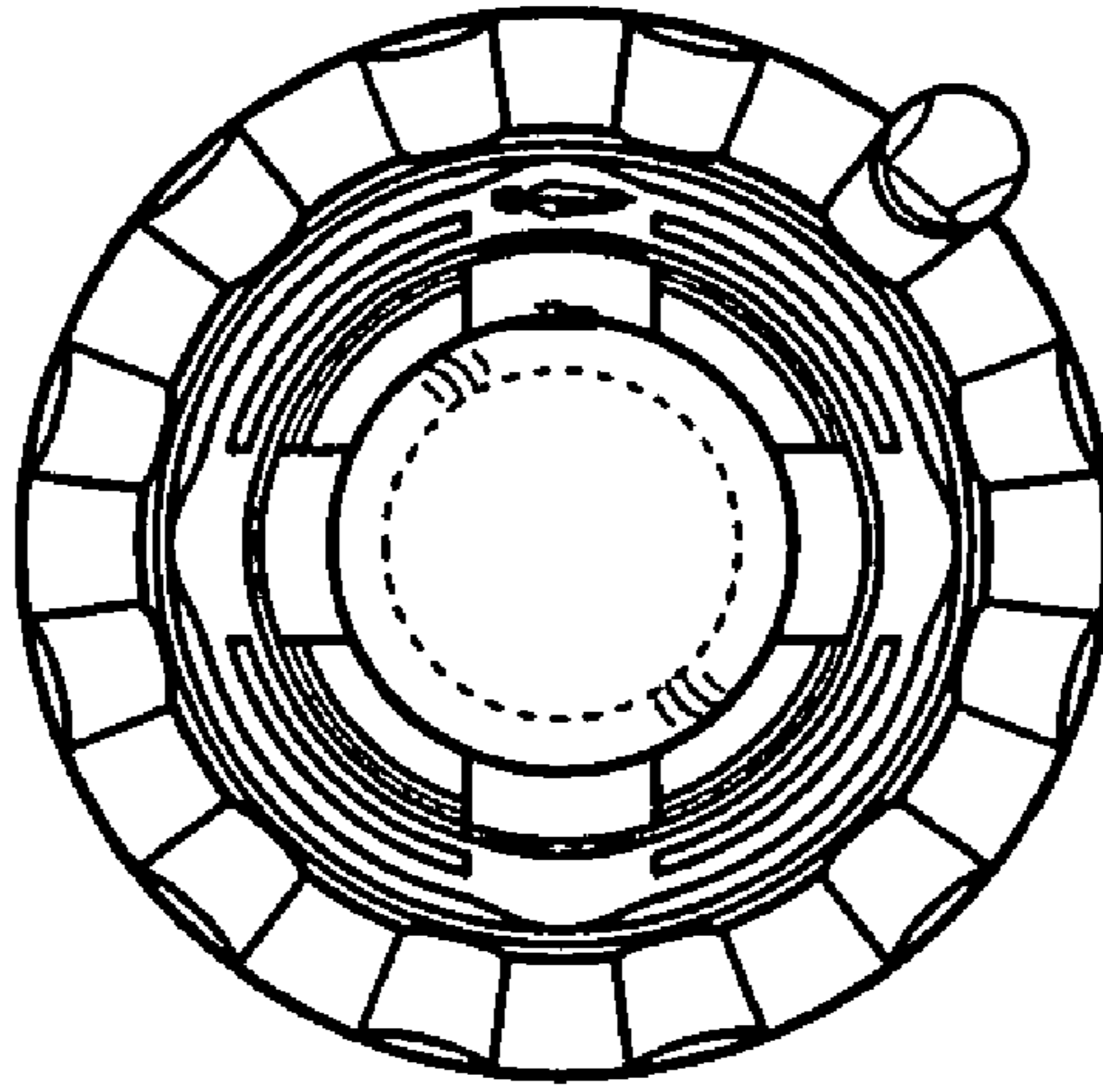

FIG. 4

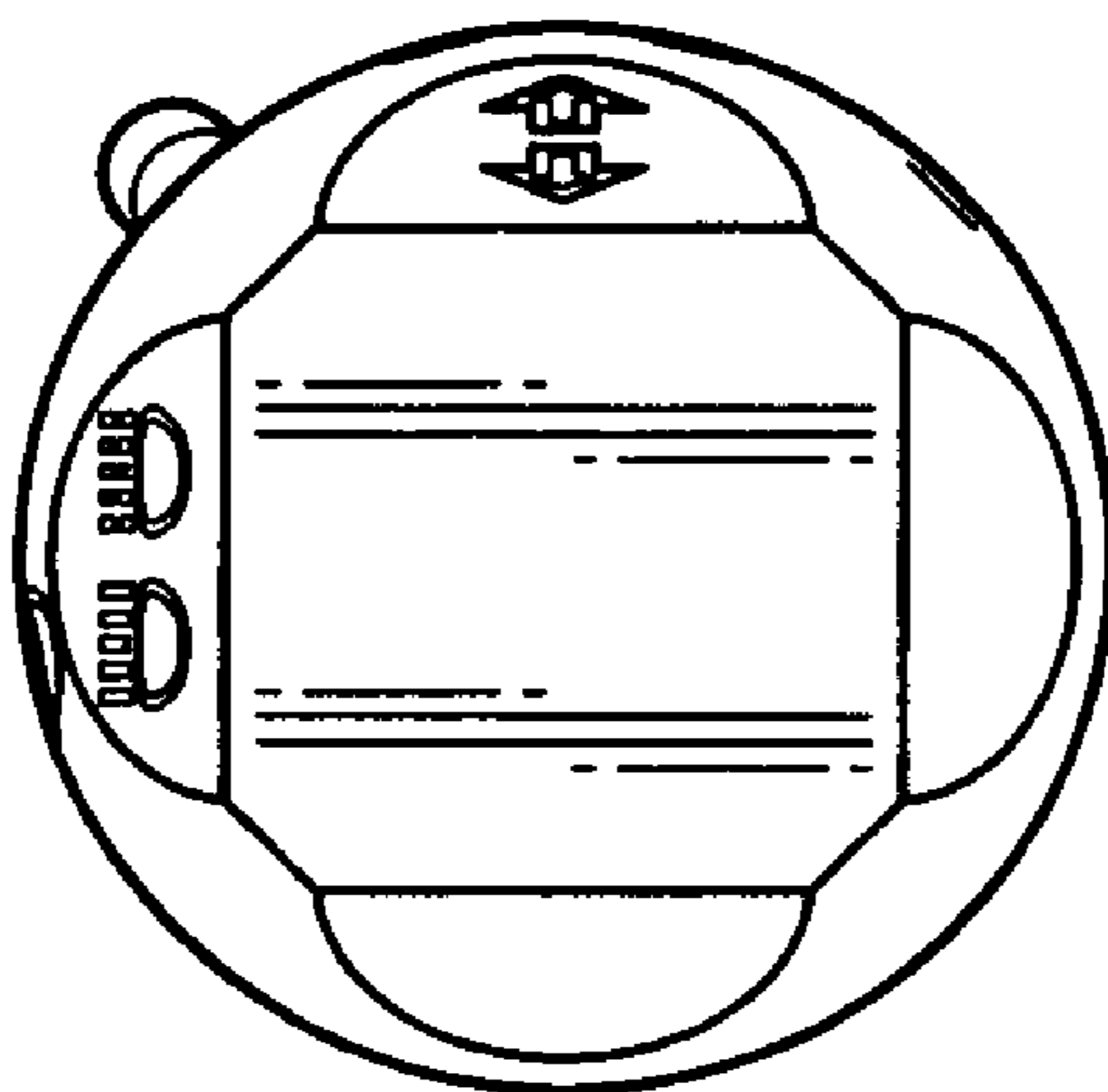

FIG. 5

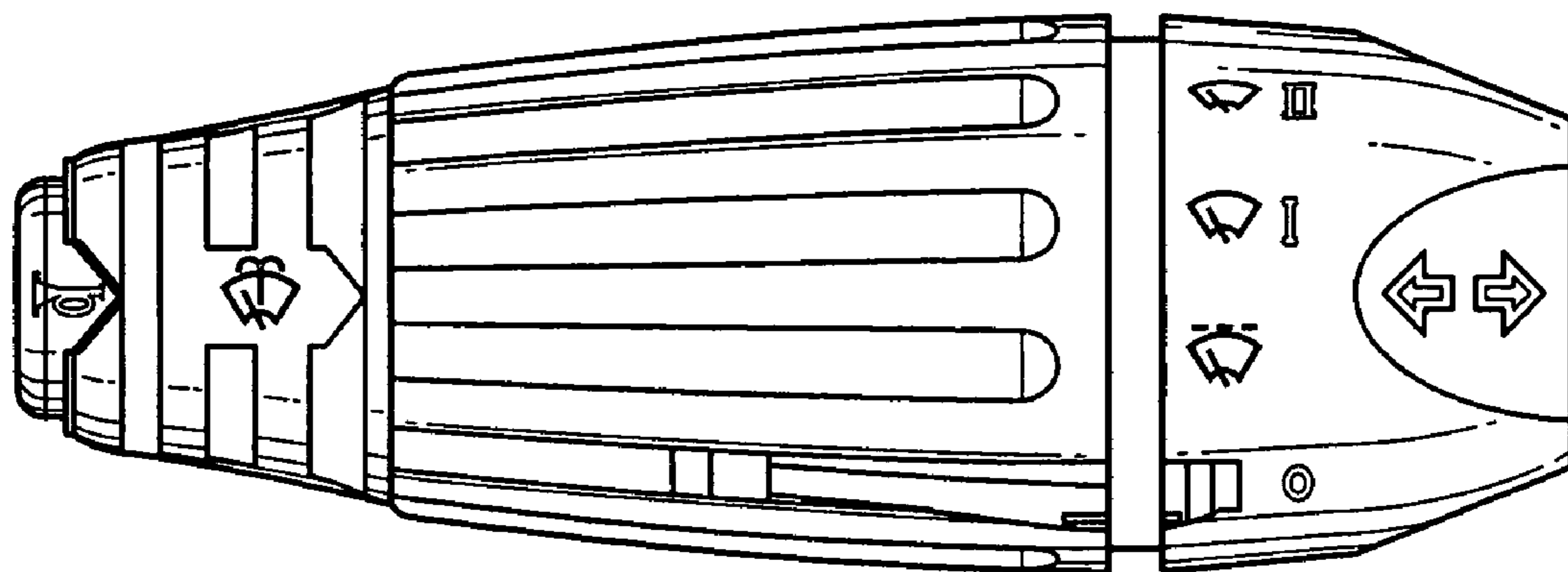

FIG. 6

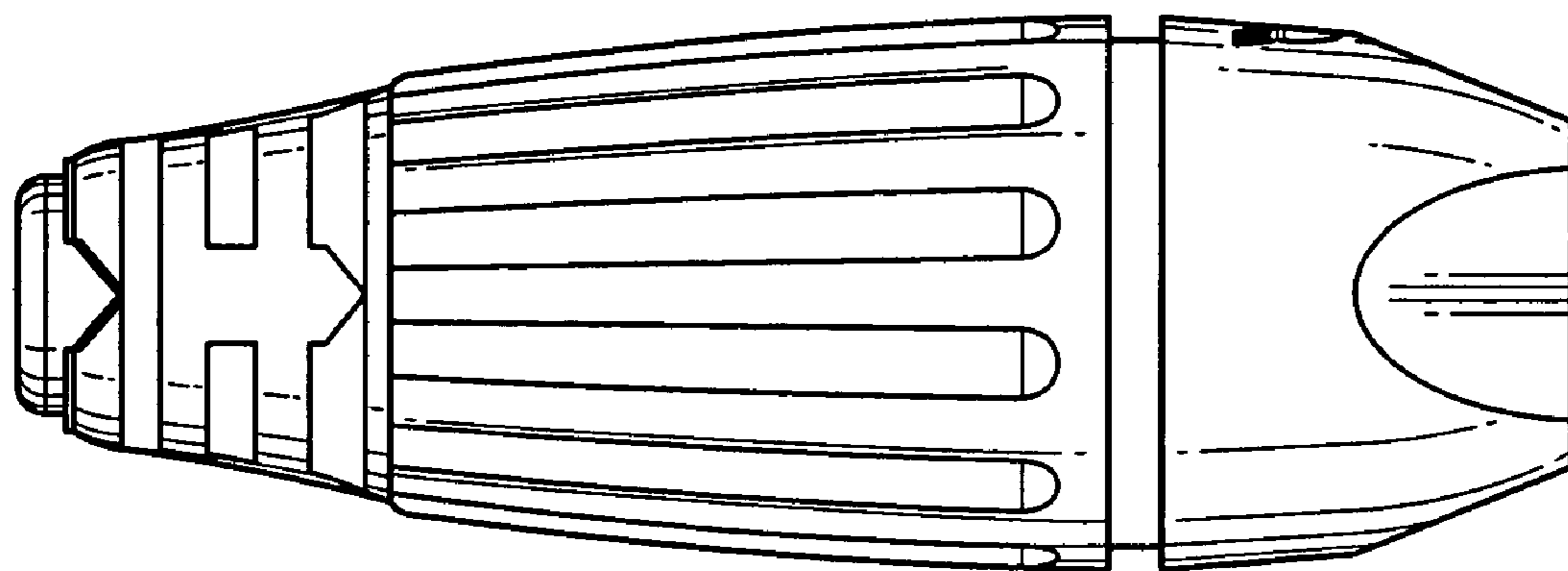

FIG. 7