



US00D568704S

(12) **United States Design Patent**
Aglassinger

(10) **Patent No.:** **US D568,704 S**

(45) **Date of Patent:** **** May 13, 2008**

(54) **SANDER**

(75) Inventor: **Hans-Peter Aglassinger**, Esslingen
(DE)

(73) Assignee: **Robert Bosch GmbH**, Stuttgart (DE)

(**) Term: **14 Years**

(21) Appl. No.: **29/284,584**

(22) Filed: **Sep. 12, 2007**

(30) **Foreign Application Priority Data**

May 15, 2007 (EM) 000723523

(51) **LOC (8) Cl.** **08-01**

(52) **U.S. Cl.** **D8/62**

(58) **Field of Classification Search** D8/69,
D8/67, 62, 61; 451/359, 358, 357, 356, 354,
451/353, 351, 344, 294; 173/168
See application file for complete search history.

(56) **References Cited**

U.S. PATENT DOCUMENTS

D385,467 S * 10/1997 Schweizer D8/62

D386,378 S * 11/1997 Henssler et al. D8/62

D447,029 S * 8/2001 Sun et al. D8/61

D459,965 S * 7/2002 Pretzell D8/62

D498,653 S * 11/2004 Wu D8/62

D500,945 S * 1/2005 Wright D8/62

D531,868 S * 11/2006 Zurwelle D8/62

* cited by examiner

Primary Examiner—Cathron C. Brooks

Assistant Examiner—Austin Murphy

(74) *Attorney, Agent, or Firm*—Victor A. Henzi

(57) **CLAIM**

The ornamental design for the sander, as shown and described.

DESCRIPTION

FIG. 1 is a rear left perspective view of the example object;

FIG. 2 is a right elevational view thereof;

FIG. 3 is a bottom plan view thereof;

FIG. 4 is a left elevational view thereof;

FIG. 5 is a top plan view thereof;

FIG. 6 is a front elevational view thereof; and,

FIG. 7 is a rear elevational view thereof.

1 Claim, 6 Drawing Sheets

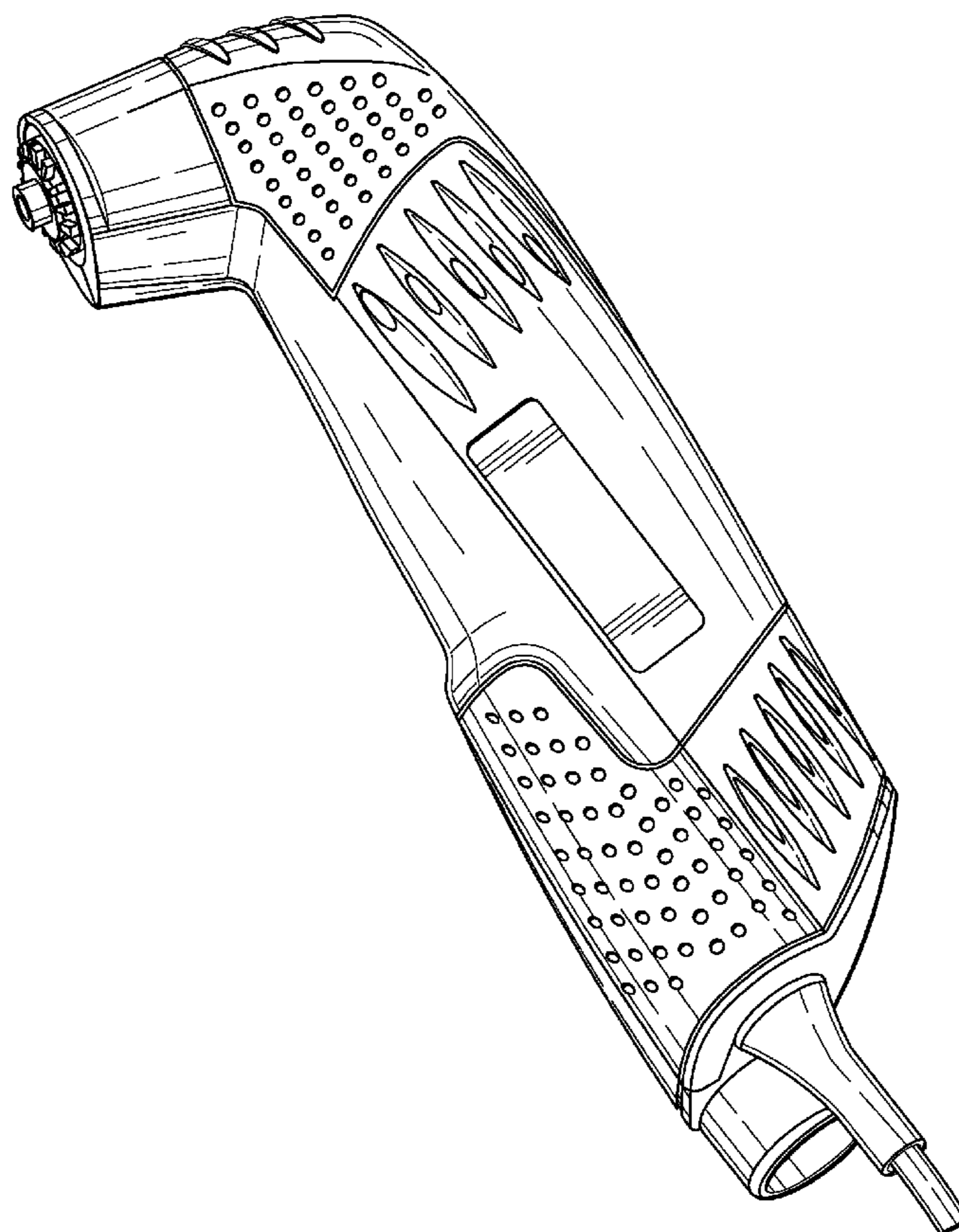

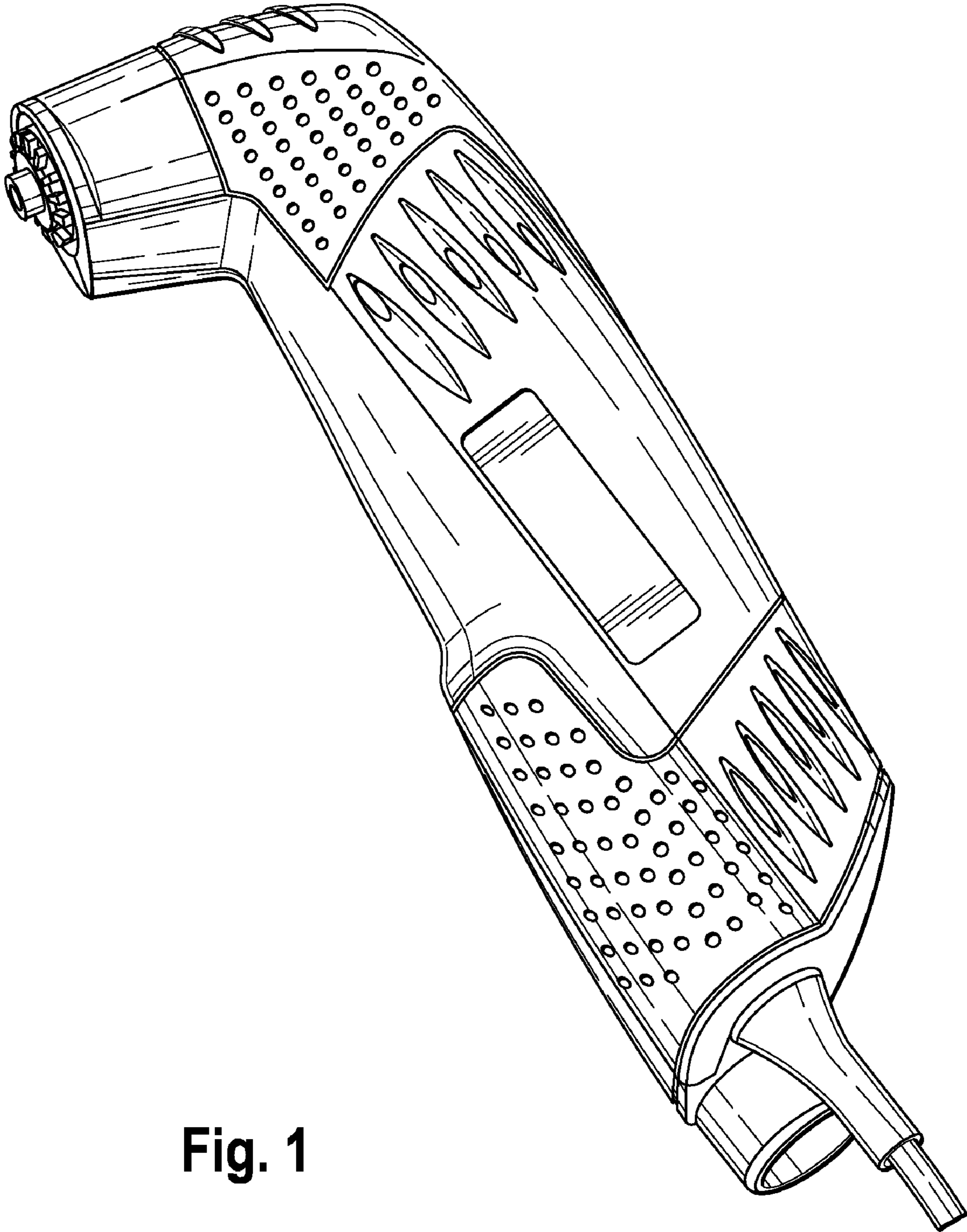

Fig. 1

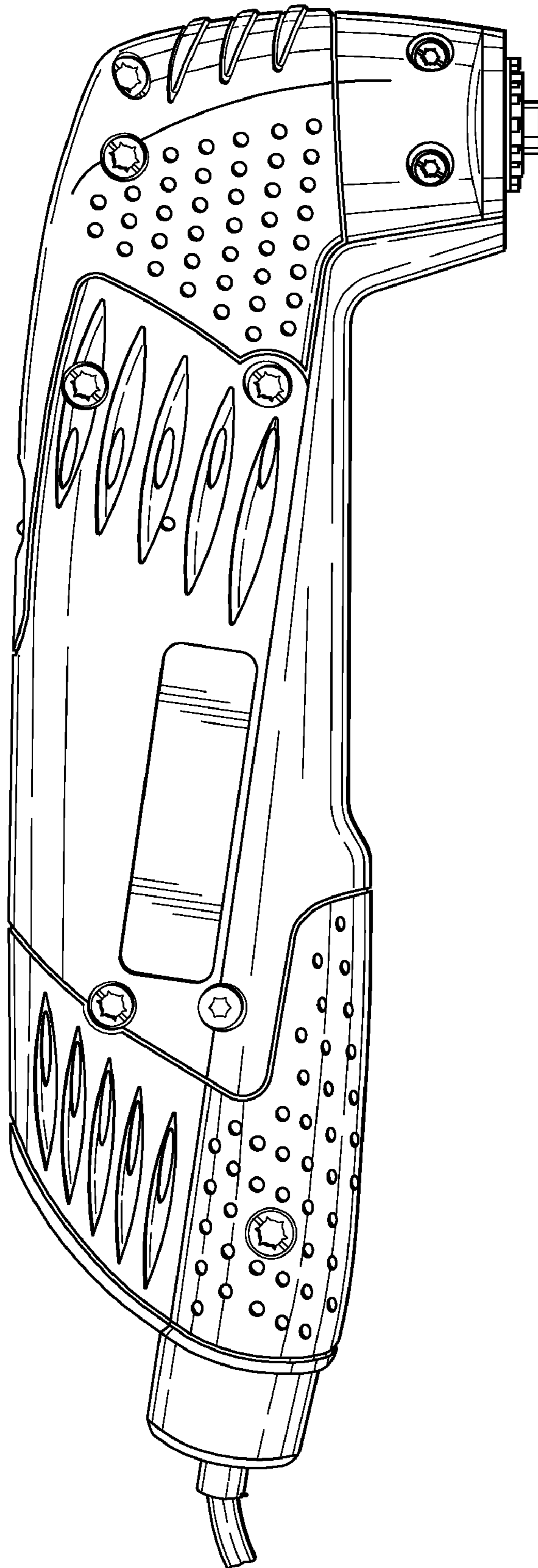

Fig. 2

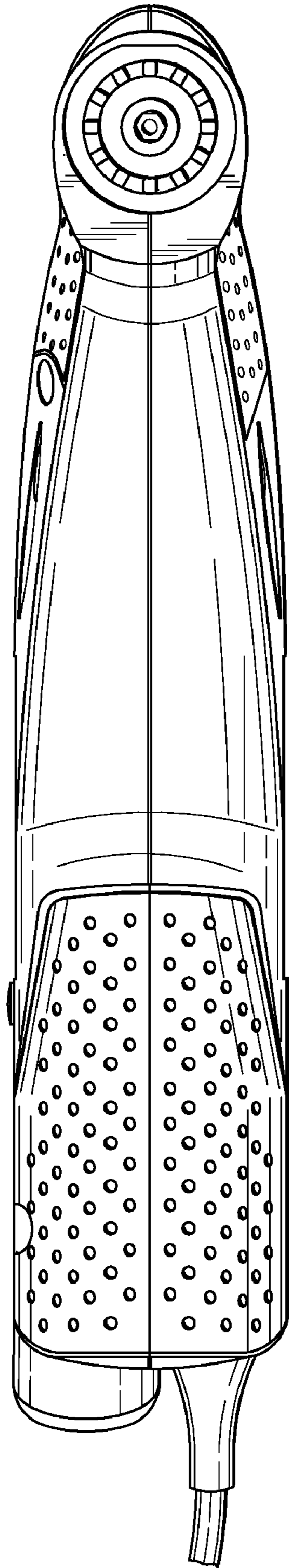

Fig. 3

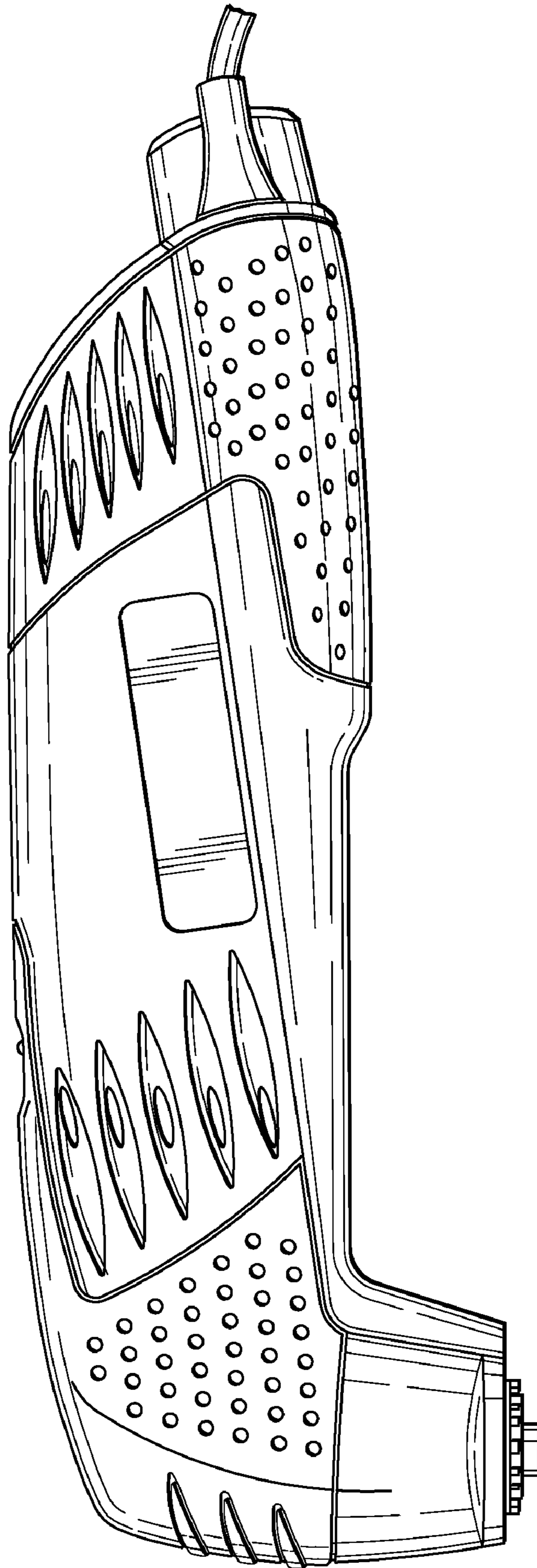

Fig. 4

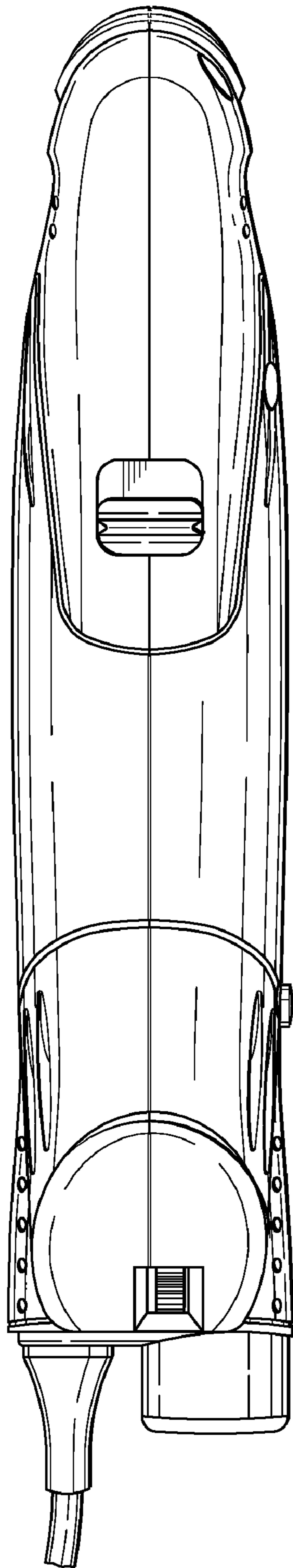

Fig. 5

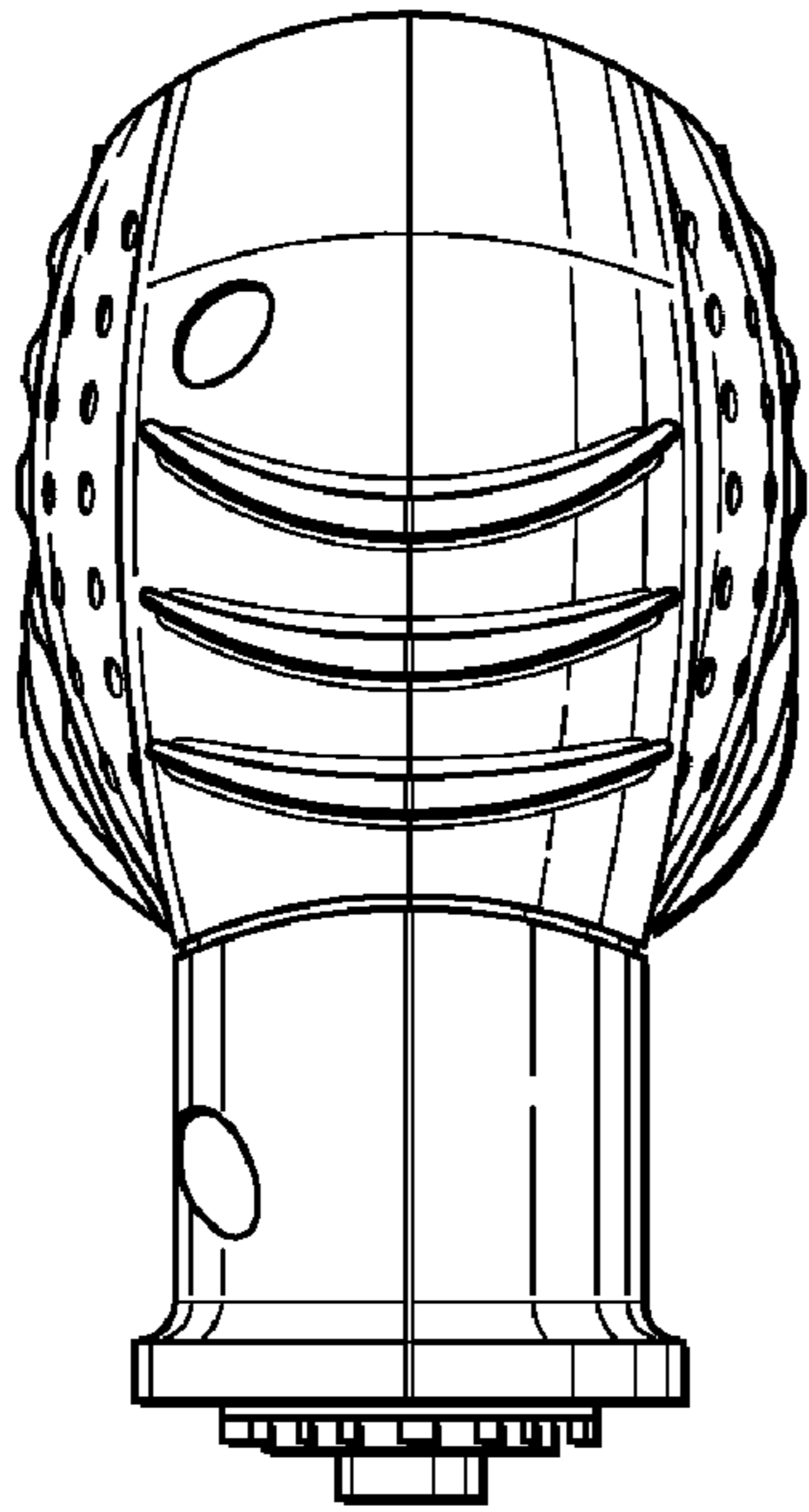

Fig. 6

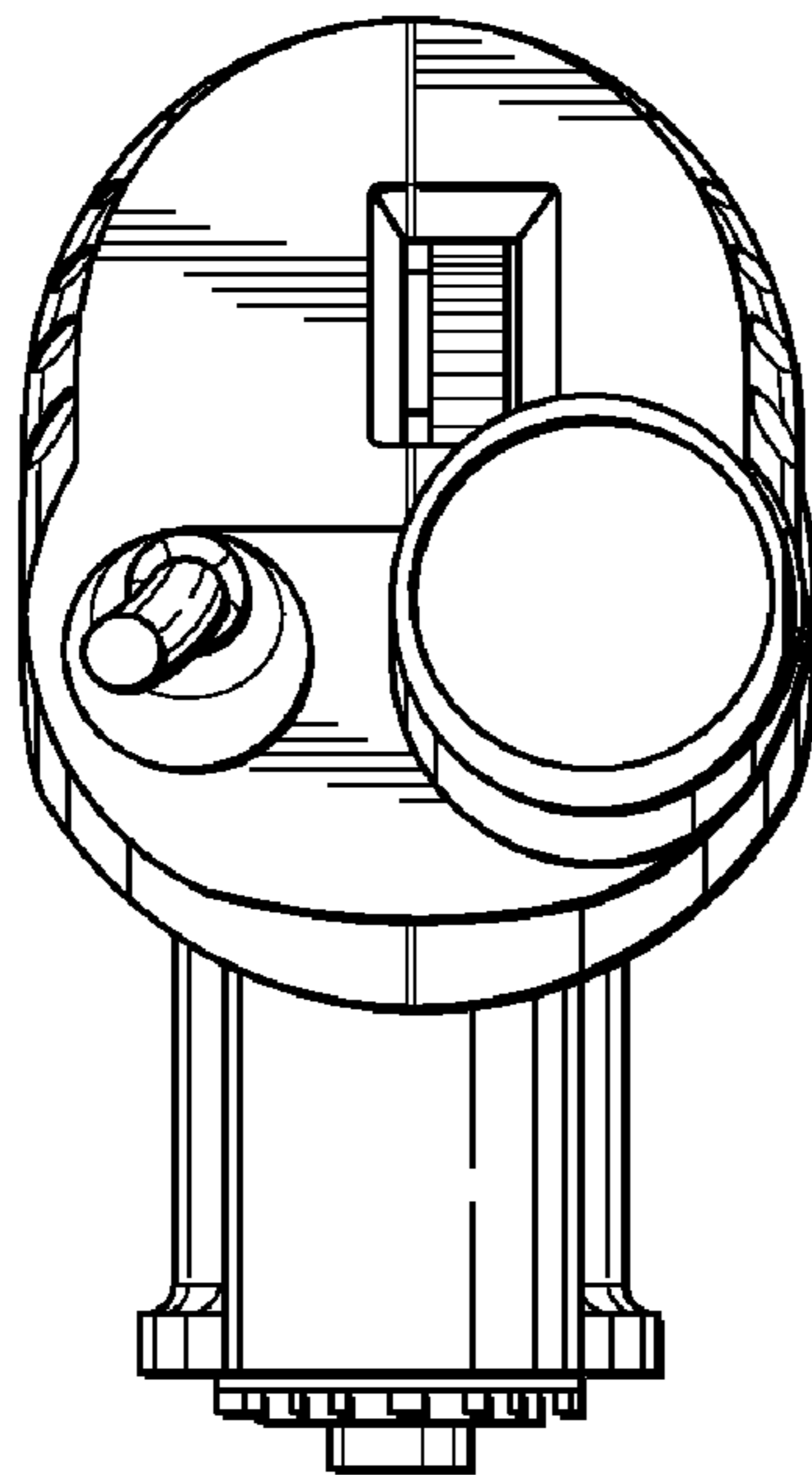

Fig. 7