



US00D568558S

(12) **United States Design Patent**
Li

(10) **Patent No.:** **US D568,558 S**

(45) **Date of Patent:** **** May 6, 2008**

(54) **JET CLEANING MACHINE**

(76) Inventor: **Jianfang Li**, Guoxiangqiao Village,
Lanjiang Street, Yuyao City, Zhejiang
Province (CN) 315409

(**) Term: **14 Years**

(21) Appl. No.: **29/287,460**

(22) Filed: **Aug. 10, 2007**

(30) **Foreign Application Priority Data**

Feb. 14, 2007 (CN) 2007 3 0004772

(51) **LOC (8) Cl.** **15-05**

(52) **U.S. Cl.** **D32/15**

(58) **Field of Classification Search** D3/1,
D3/4, 15, 17, 21-23, 31, 33-34; 15/320-323,
15/327.1-327.2, 327.4-327.7, 344, 347,
15/353, 410, 412, 414, 415.1-422

See application file for complete search history.

(56) **References Cited**

U.S. PATENT DOCUMENTS

- D325,453 S * 4/1992 Tsuge D32/21
- D386,842 S * 11/1997 Hoshino et al. D32/21
- D418,643 S * 1/2000 Hoshino D32/21
- 6,101,669 A * 8/2000 Martin et al. 15/327.2
- D443,736 S * 6/2001 Warth D32/15
- D462,488 S * 9/2002 Santiago et al. D32/18
- D496,764 S * 9/2004 Lopano D32/21
- D536,147 S * 1/2007 Medema et al. D32/18

- D537,216 S * 2/2007 Davis et al. D32/18
- D537,586 S * 2/2007 Renner D32/23
- D549,893 S * 8/2007 Chen D32/4
- 2006/0207052 A1 * 9/2006 Tran 15/320

OTHER PUBLICATIONS

<http://www.ridgid.com/assets/thumpnail.asp?path=/ASSETS/E11464821CD44B5C9573ABF4195A84DB/> Dec. 7, 2007.*

http://www.allbrands.com/images/products_main/M_13000_ep923.jpg Dec. 7, 2007.*

* cited by examiner

Primary Examiner—Louis S. Zarfaz

Assistant Examiner—Kathleen Sims

(74) *Attorney, Agent, or Firm*—Sughrue Mion, PLLC

(57) **CLAIM**

The ornamental design for a jet cleaning machine, as shown.

DESCRIPTION

FIG. 1 is a front elevation view of a jet cleaning machine showing my new design;

FIG. 2 is a rear elevation view thereof;

FIG. 3 is a side elevation view thereof;

FIG. 4 is a opposite side elevation view thereof;

FIG. 5 is a top plan view thereof;

FIG. 6 is a bottom plan view thereof; and,

FIG. 7 is a perspective view thereof.

1 Claim, 7 Drawing Sheets

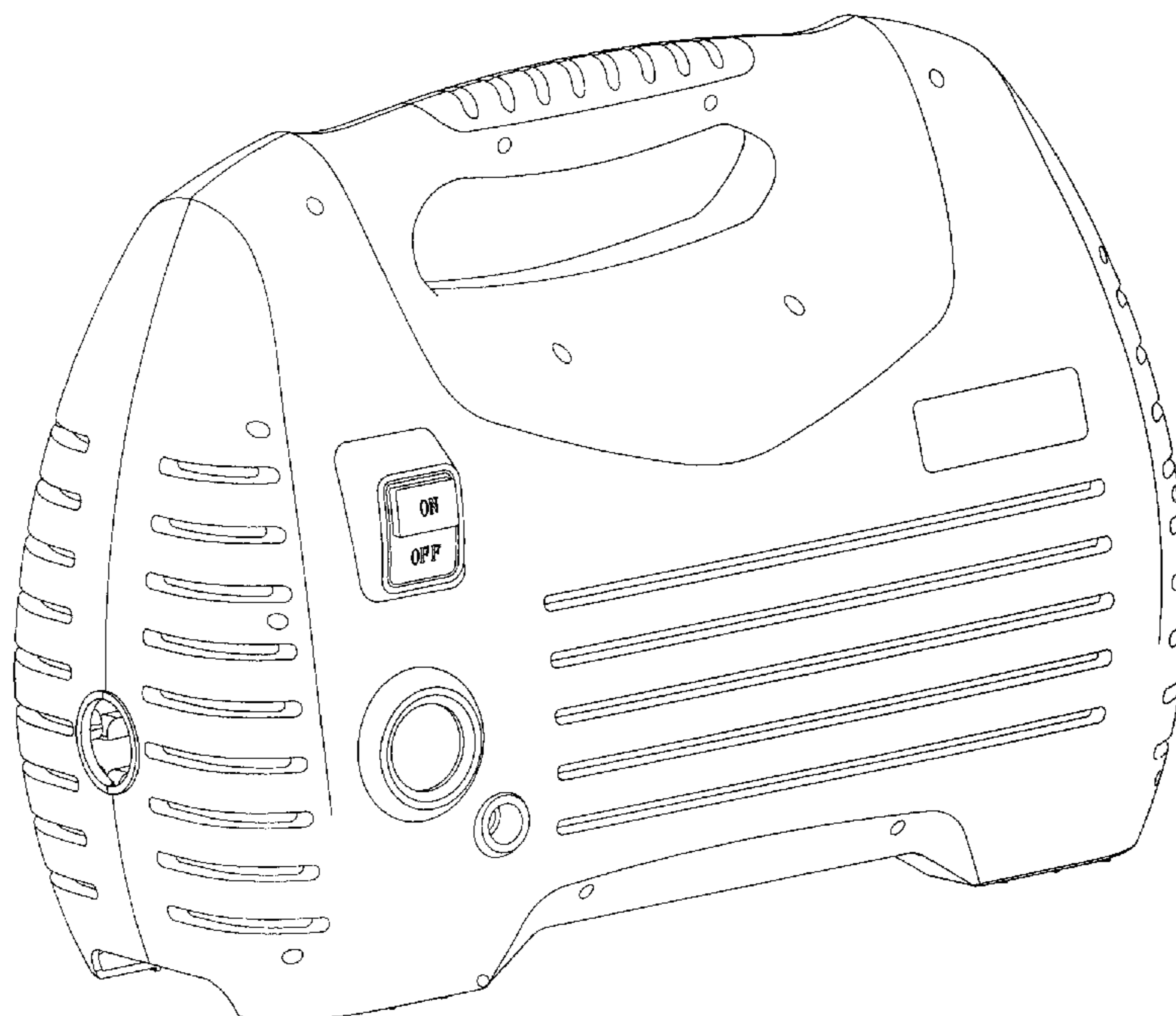

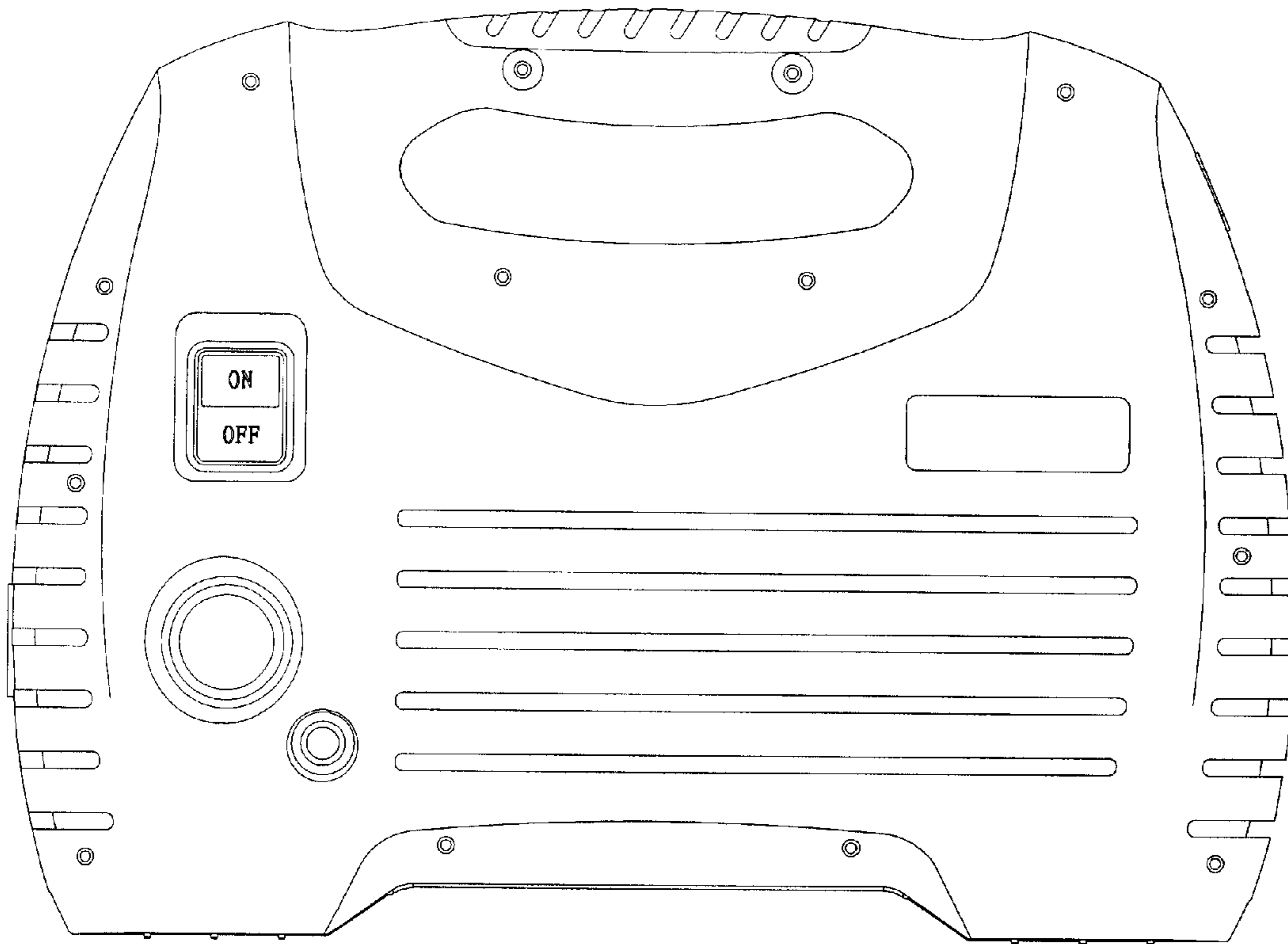

FIG. 1

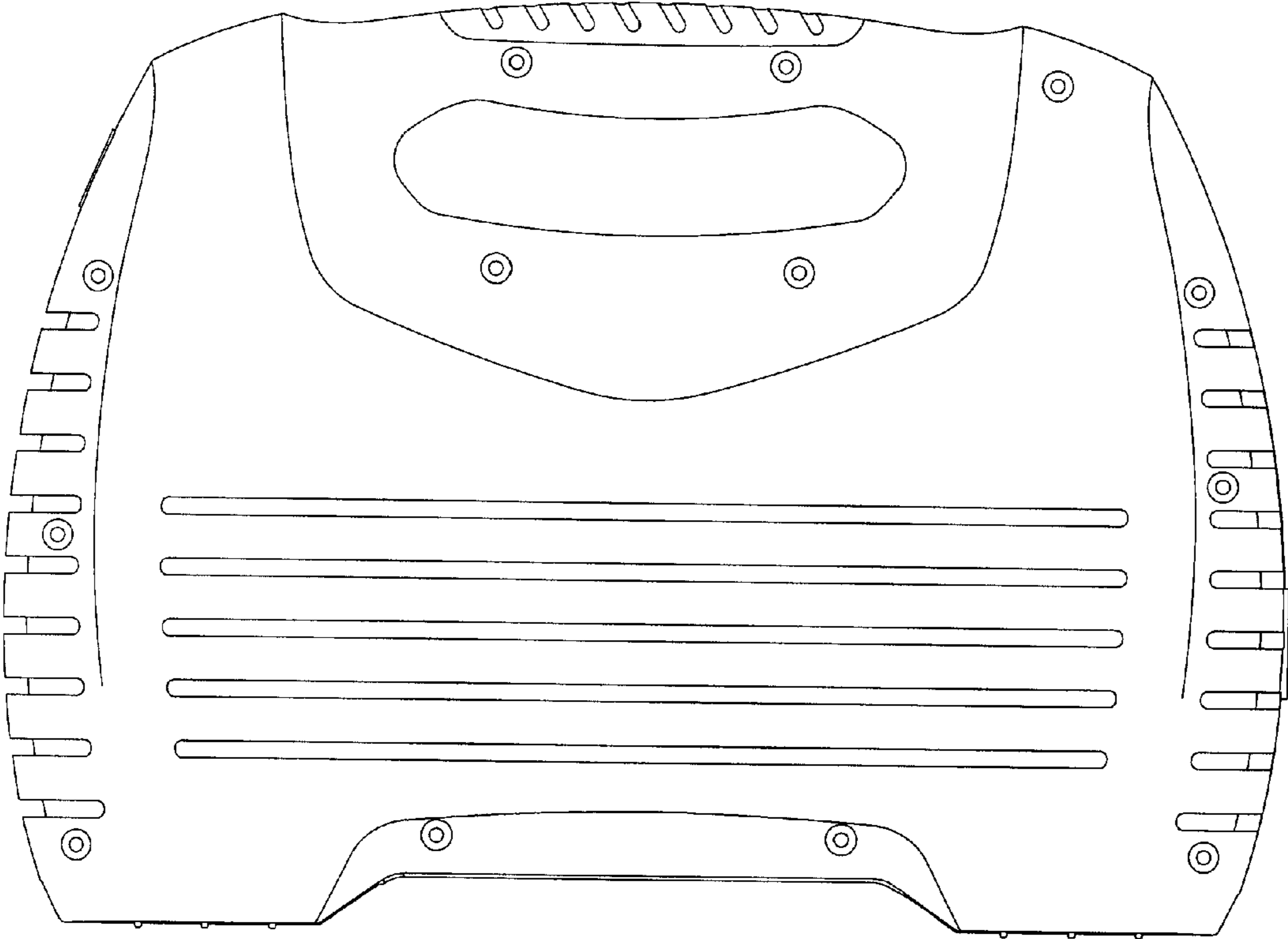

FIG. 2

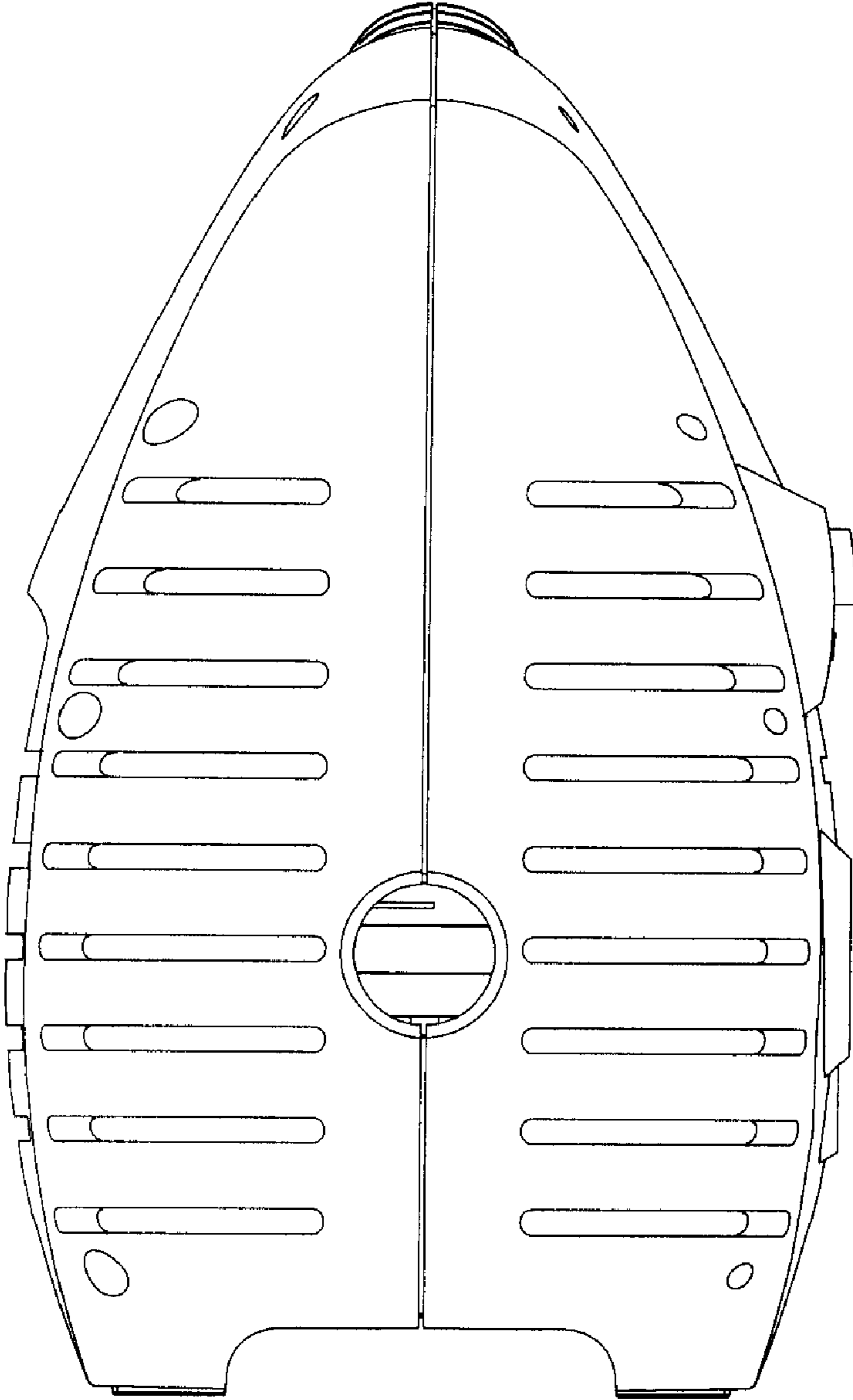

FIG. 3

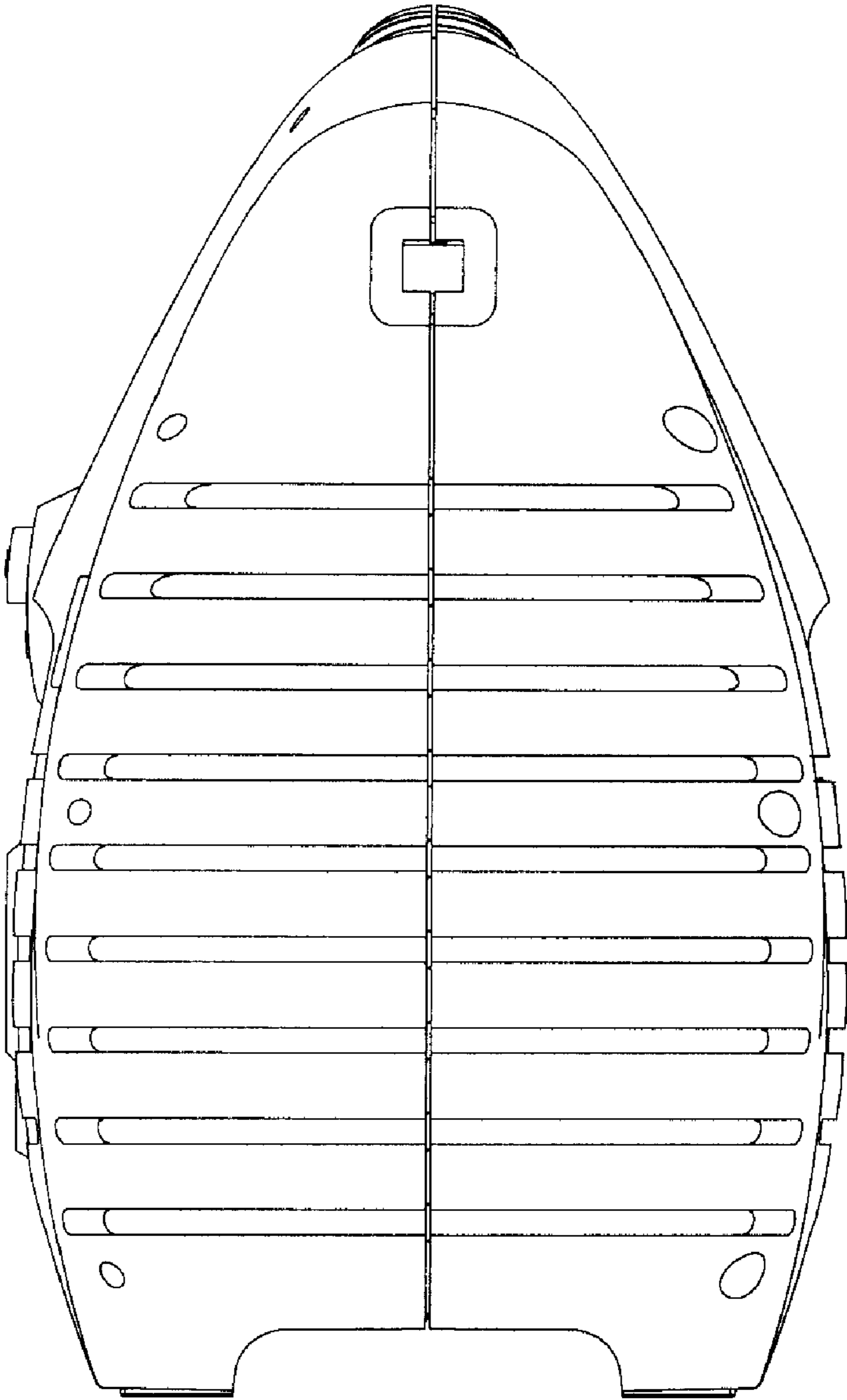

FIG. 4

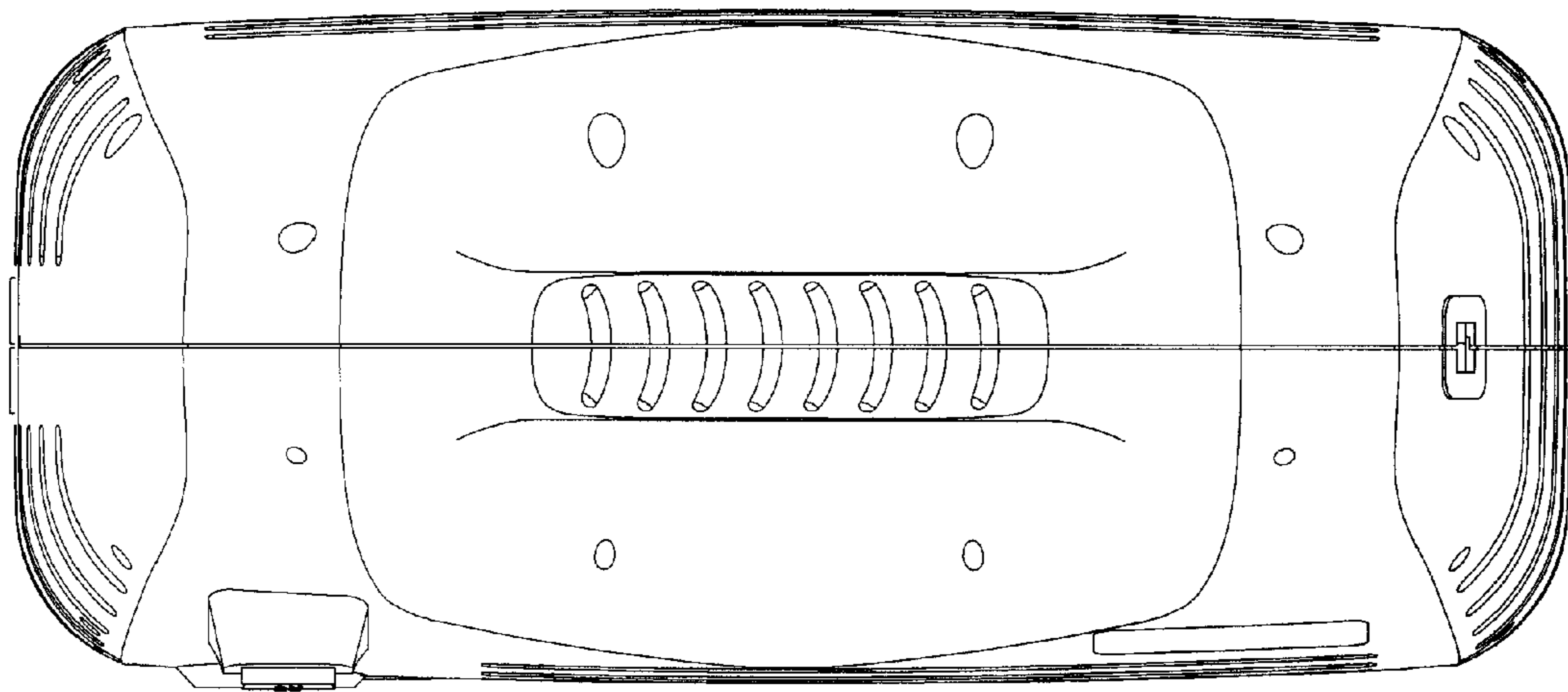

FIG. 5

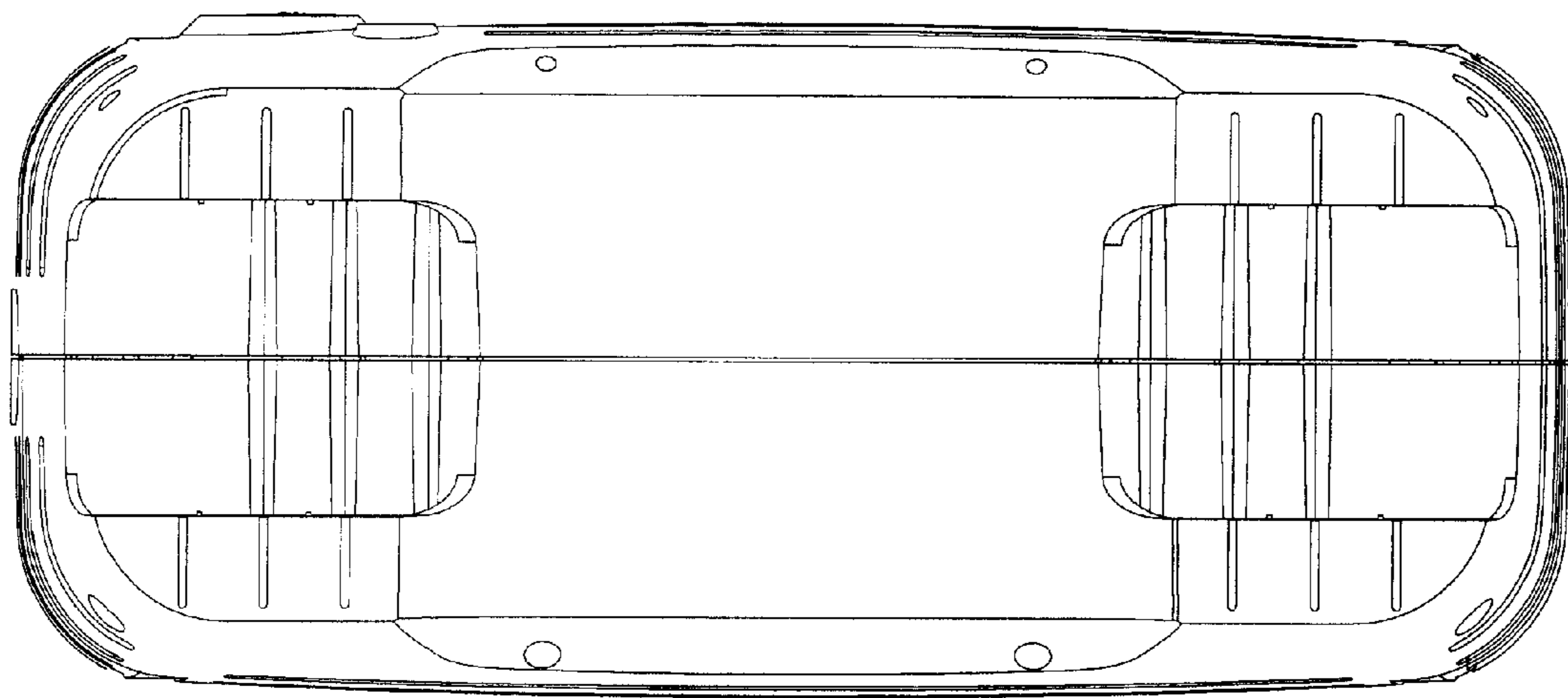

FIG. 6

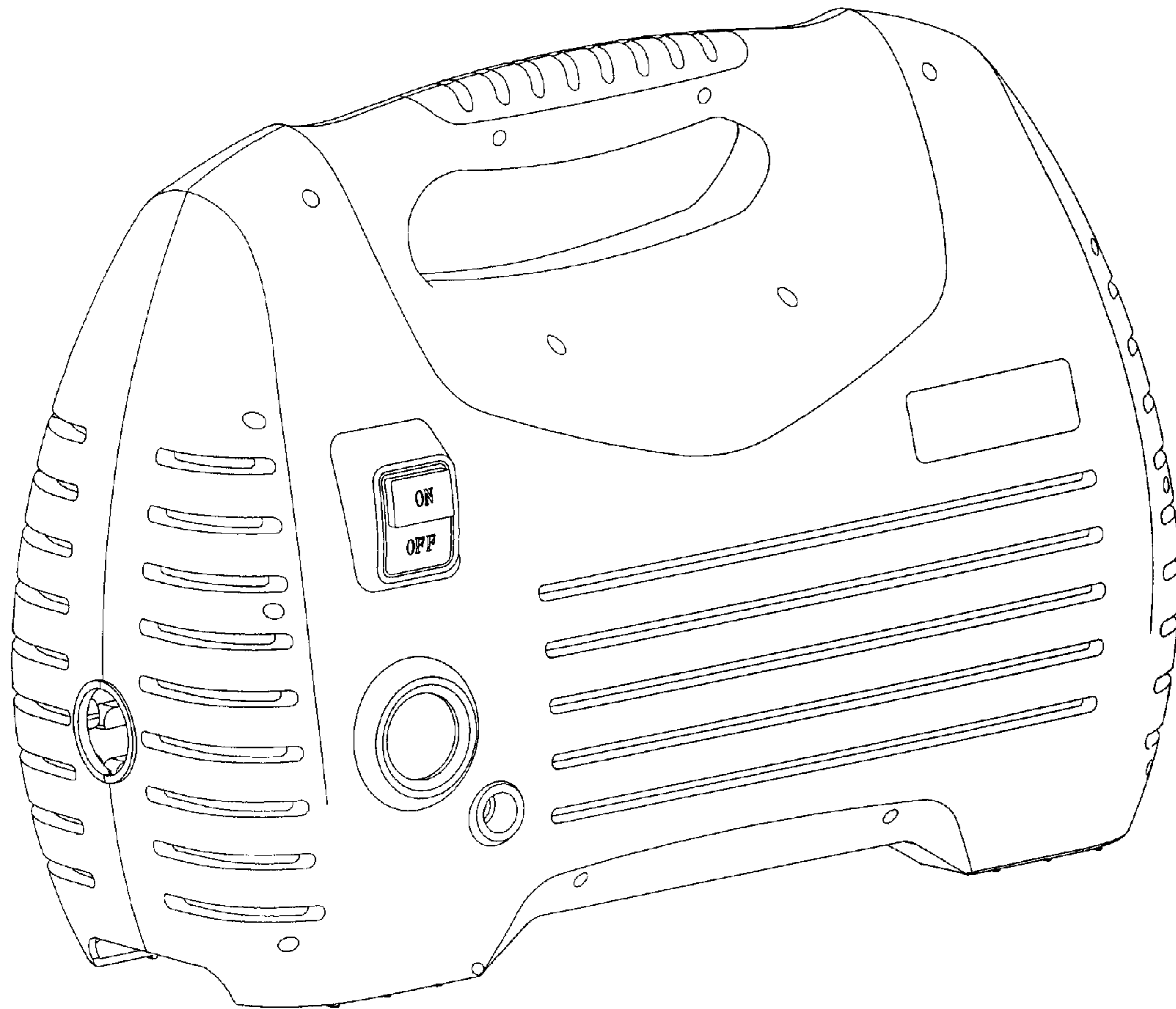

FIG. 7