



US00D568223S

(12) **United States Design Patent**
Simpson

(10) **Patent No.:** **US D568,223 S**

(45) **Date of Patent:** **** May 6, 2008**

- (54) **VEHICLE WHEEL FRONT FACE**
- (75) Inventor: **David T. Simpson**, Covington, GA (US)
- (73) Assignee: **Clarence Hall**, Conyers, GA (US)
- (**) Term: **14 Years**
- (21) Appl. No.: **29/202,686**
- (22) Filed: **Apr. 1, 2004**
- (51) **LOC (8) Cl.** **12-16**
- (52) **U.S. Cl.** **D12/209**
- (58) **Field of Classification Search** D12/207-213;
301/37.101, 64.101, 65; 42/58, 59, 62
See application file for complete search history.

(56) **References Cited**

U.S. PATENT DOCUMENTS

1,004,023	A *	9/1911	Heibeck	301/64.101
2,944,358	A *	7/1960	Weimer	42/58
3,683,536	A *	8/1972	Sefried, II	42/62
3,744,171	A *	7/1973	Fecke	42/89
D501,439	S *	2/2005	Chiu	D12/209
2006/0101698	A1 *	5/2006	Lin	42/89

* cited by examiner

Primary Examiner—Robert M. Spear
Assistant Examiner—George D Kirschbaum
 (74) *Attorney, Agent, or Firm*—Michael J. Bootcheck, LLC;
 Michael J. Bootcheck

(57) **CLAIM**

The ornamental design for a vehicle wheel front face, as shown and described.

DESCRIPTION

FIG. 1 is a perspective view of a vehicle wheel front face according to one arrangement of the present design.

FIG. 2 is a front view of the vehicle wheel front face shown in FIG. 1.

FIG. 3 is a perspective view of a second embodiment of a vehicle wheel front face according to the present design; and,

FIG. 4 is a front view of the vehicle wheel front face shown in FIG. 3.

The broken lines shown herein are for illustrative purposes only and form no part of the claimed design.

1 Claim, 4 Drawing Sheets

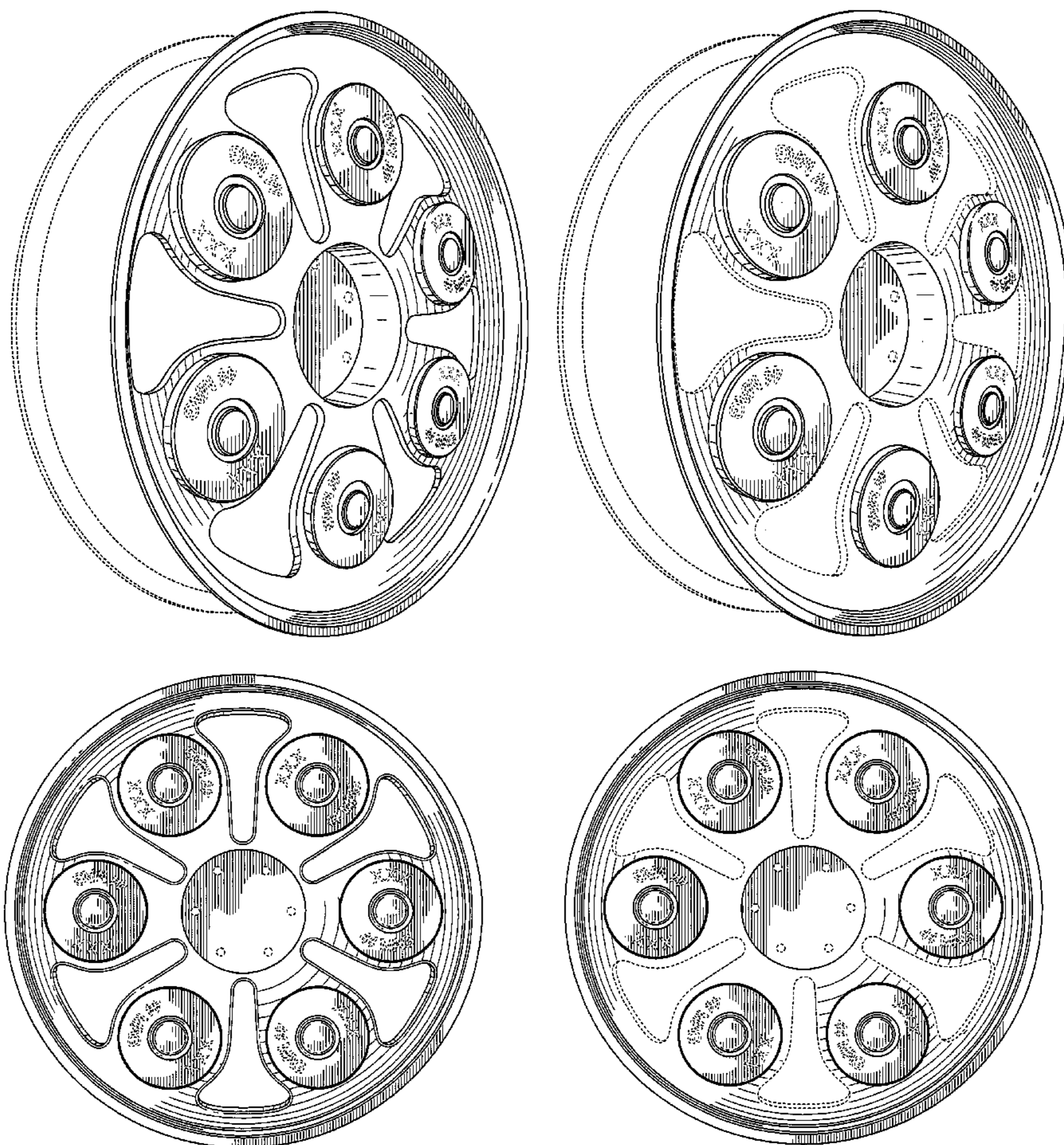

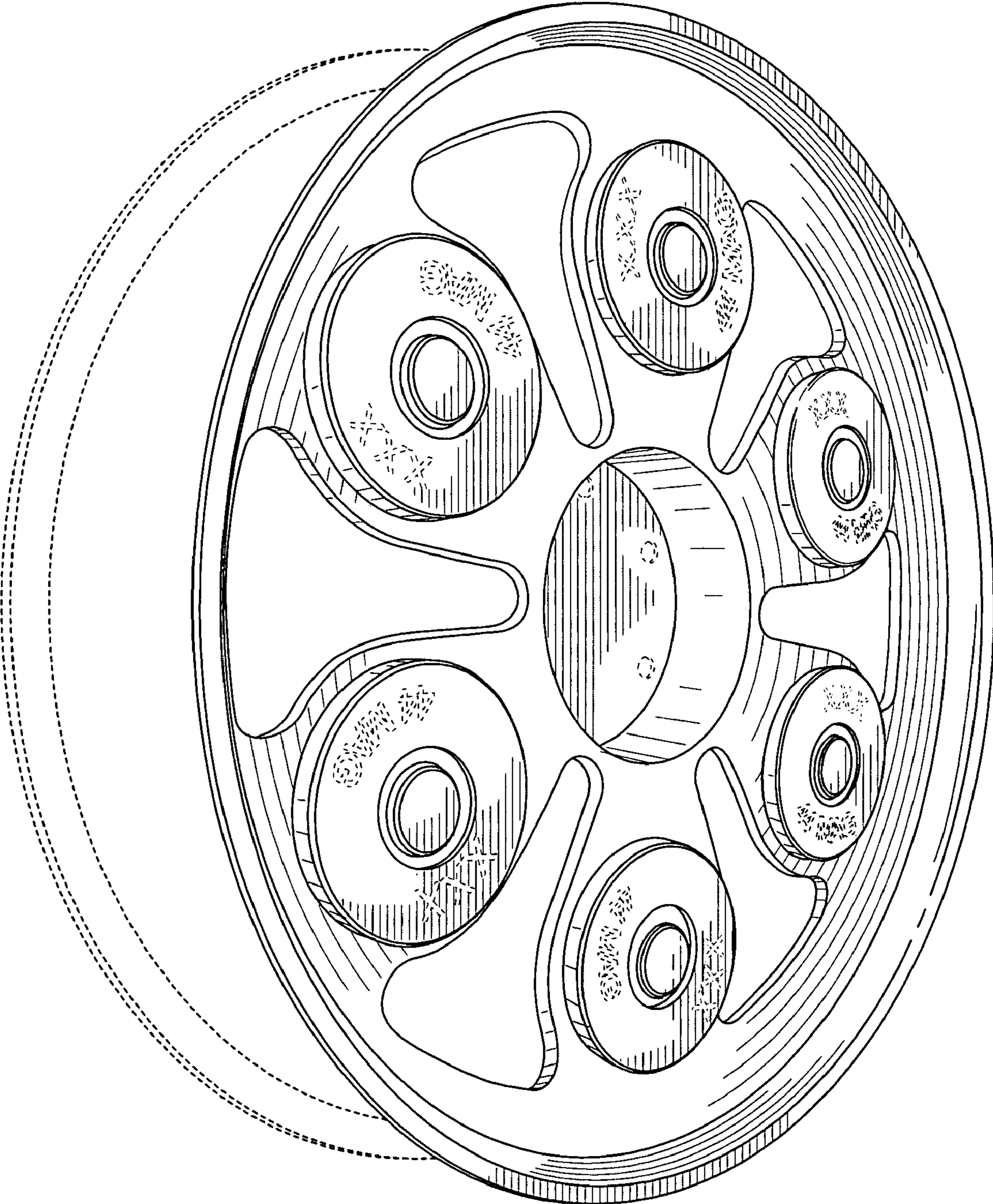

FIG. 1

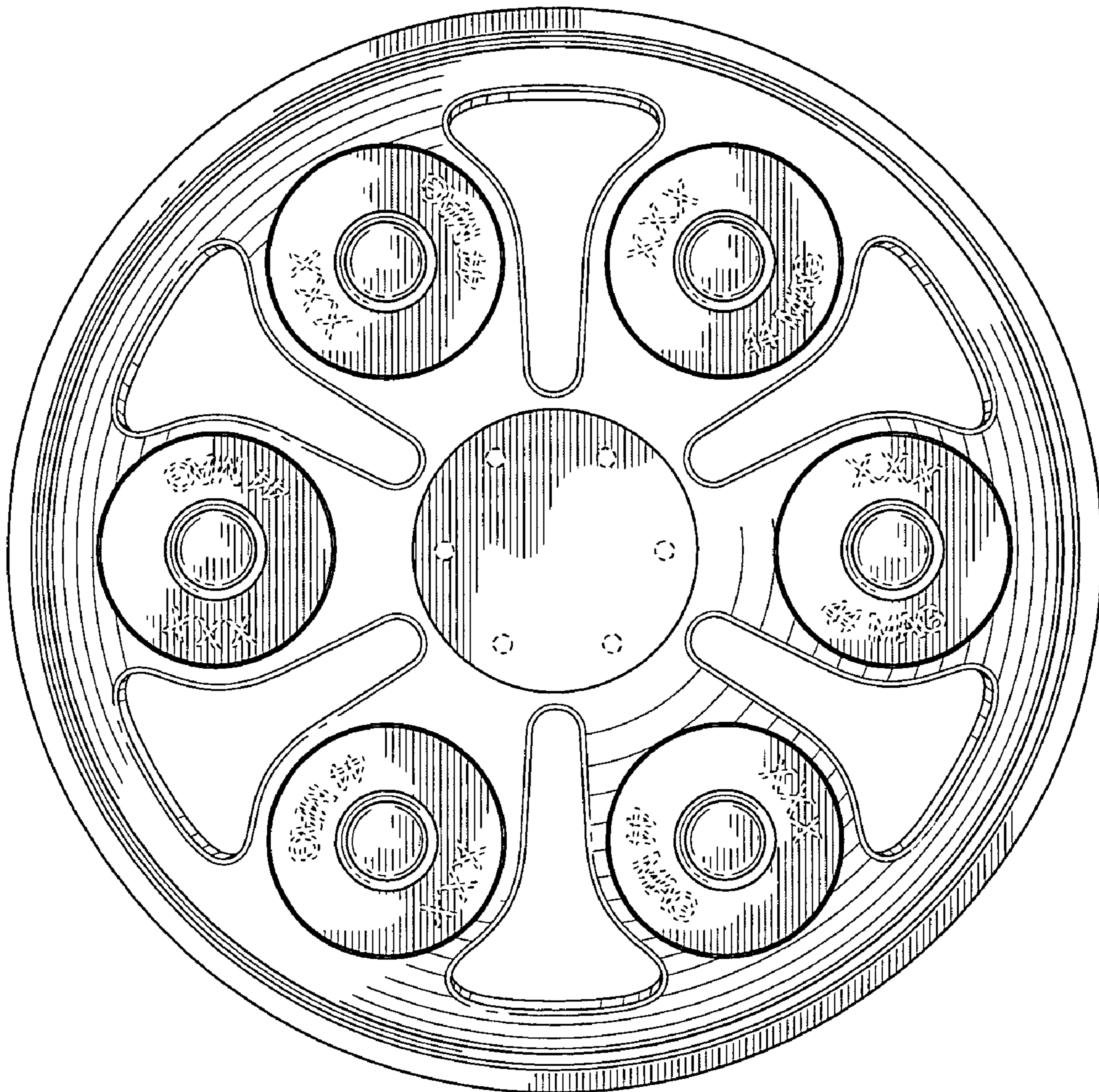

FIG. 2

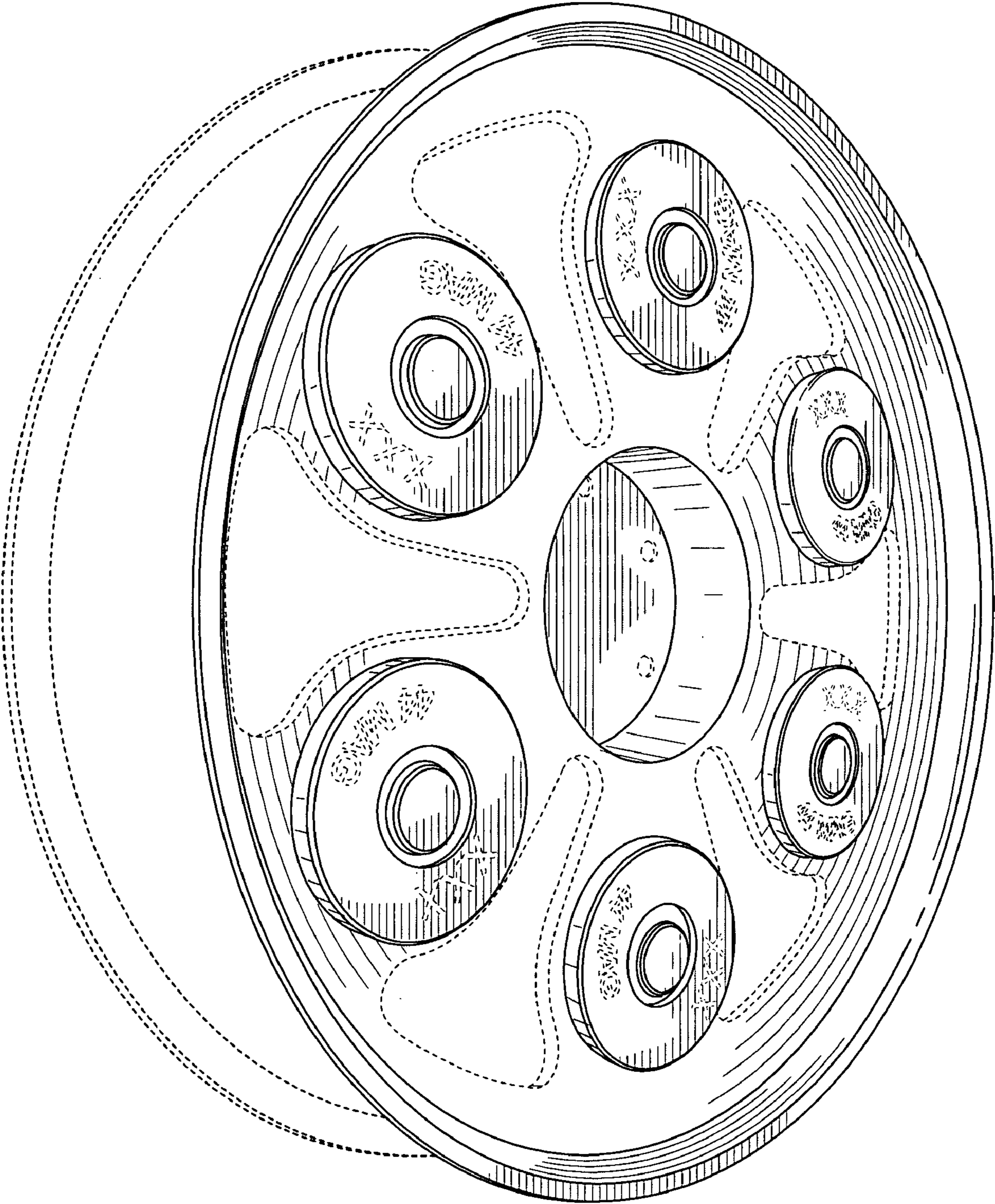

FIG. 3

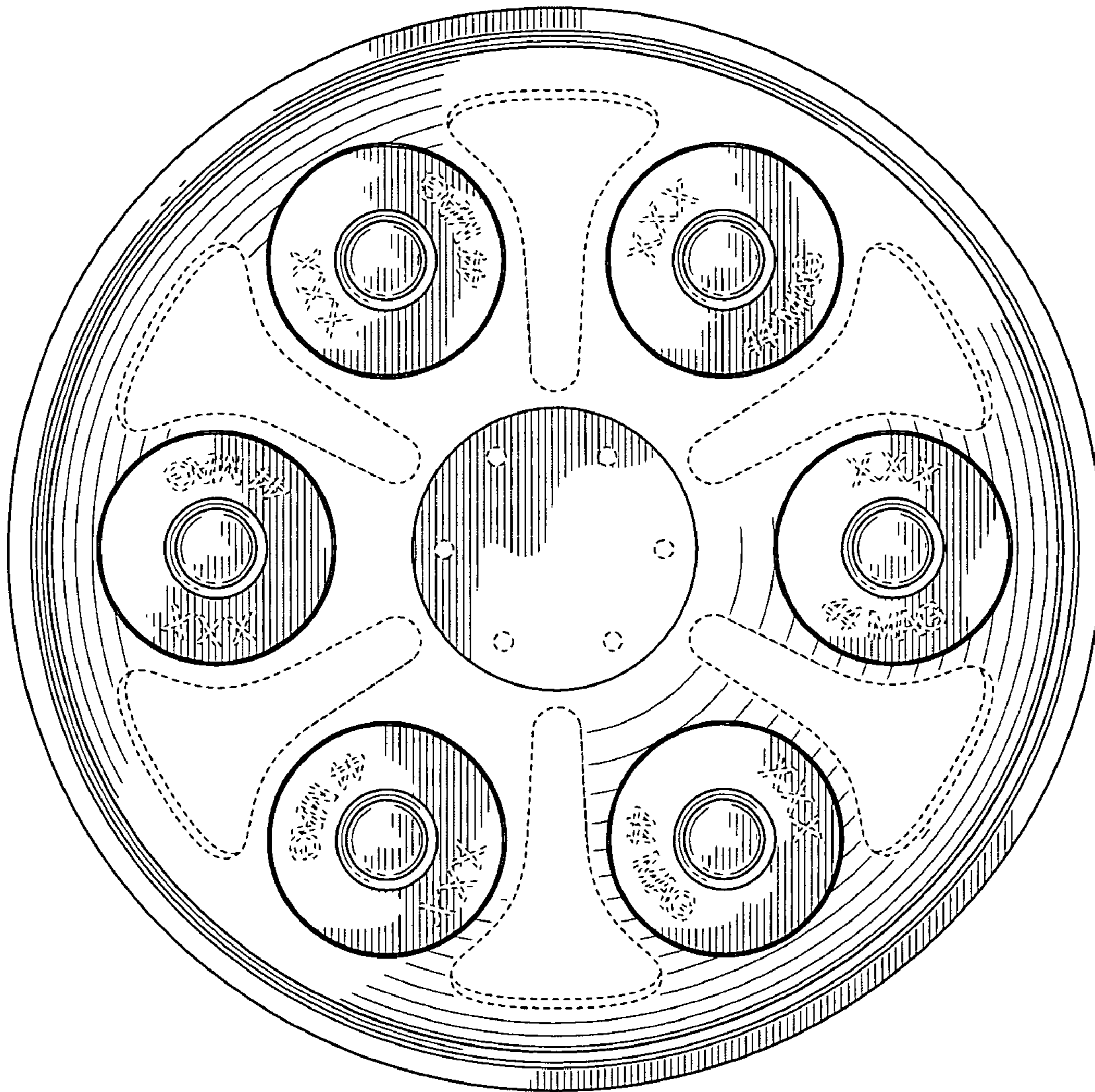

FIG. 4