

US00D568219S

(12) **United States Design Patent**
Schowalter

(10) **Patent No.:** **US D568,219 S**
(45) **Date of Patent:** **** May 6, 2008**

(54) **PORTION OF A VEHICLE INSTRUMENT
PANEL**

(75) Inventor: **Jean-Paul Schowalter**, Fullerton, CA
(US)

(73) Assignee: **Honda Motor Co., Ltd.**, Tokyo (JP)

(**) Term: **14 Years**

(21) Appl. No.: **29/250,671**

(22) Filed: **Nov. 27, 2006**

(51) **LOC (8) Cl.** **12-16**

(52) **U.S. Cl.** **D12/192**

(58) **Field of Classification Search** D12/192,
D12/345, 317, 415, 421, 423; 180/90; 280/750-752;
296/190.01-190.09, 70; D15/17, 28; D10/46,
D10/98, 102-103; 362/482, 489; 73/431,
73/866.3

See application file for complete search history.

(56) **References Cited**

U.S. PATENT DOCUMENTS

- D318,255 S * 7/1991 Maxwell D12/192
- D433,361 S * 11/2000 Wollmer et al. D12/192
- D433,362 S * 11/2000 Wyszgrod et al. D12/192
- D456,340 S * 4/2002 Boulay et al. D12/415
- D473,174 S * 4/2003 Pfeiffer et al. D12/192

- D492,231 S * 6/2004 Robinson D12/192
- D495,641 S * 9/2004 Nakajima et al. D12/192
- D498,191 S * 11/2004 Nakajima et al. D12/192
- D528,485 S * 9/2006 Montijo et al. D12/192

* cited by examiner

Primary Examiner—Stacia Cadmus

(74) *Attorney, Agent, or Firm*—Mark E. Duell; Plumsea
Law Group, LLC

(57) **CLAIM**

The ornamental design for a portion of a vehicle instrument
panel, as shown and described.

DESCRIPTION

FIG. 1 is a perspective view of a portion of a vehicle
instrument panel showing my new design;

FIG. 2 is a front view thereof; and,

FIG. 3 is a perspective view of the portion of a vehicle
instrument panel, shown in closed position.

The broken line showings of the indicia on the controllers
and the lines in the display area are for illustrative purposes
only and form no part of the claimed design. The uneven
broken line represents a boundary of the claim and is not
intended to form a part of the claimed design.

1 Claim, 2 Drawing Sheets

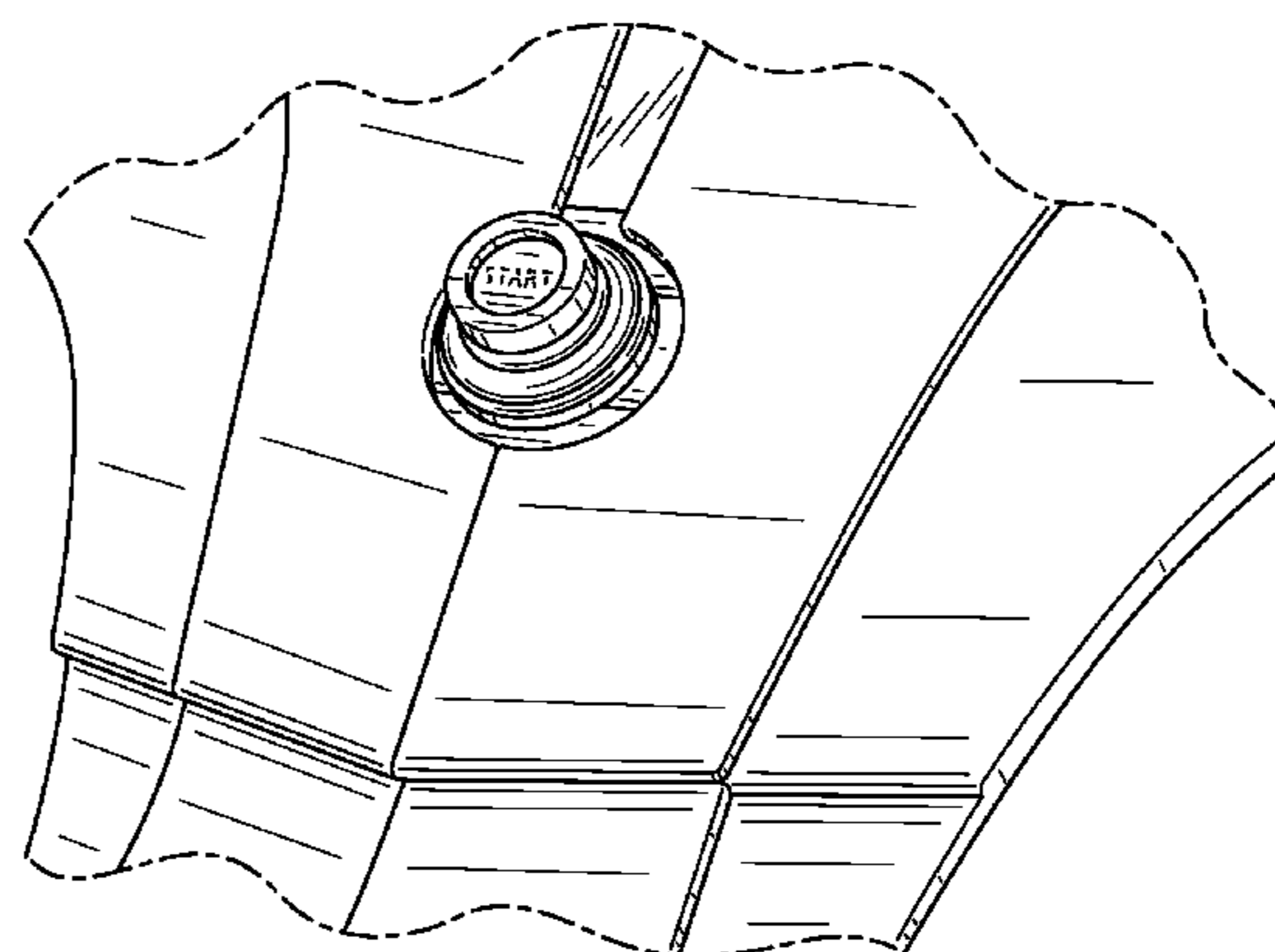
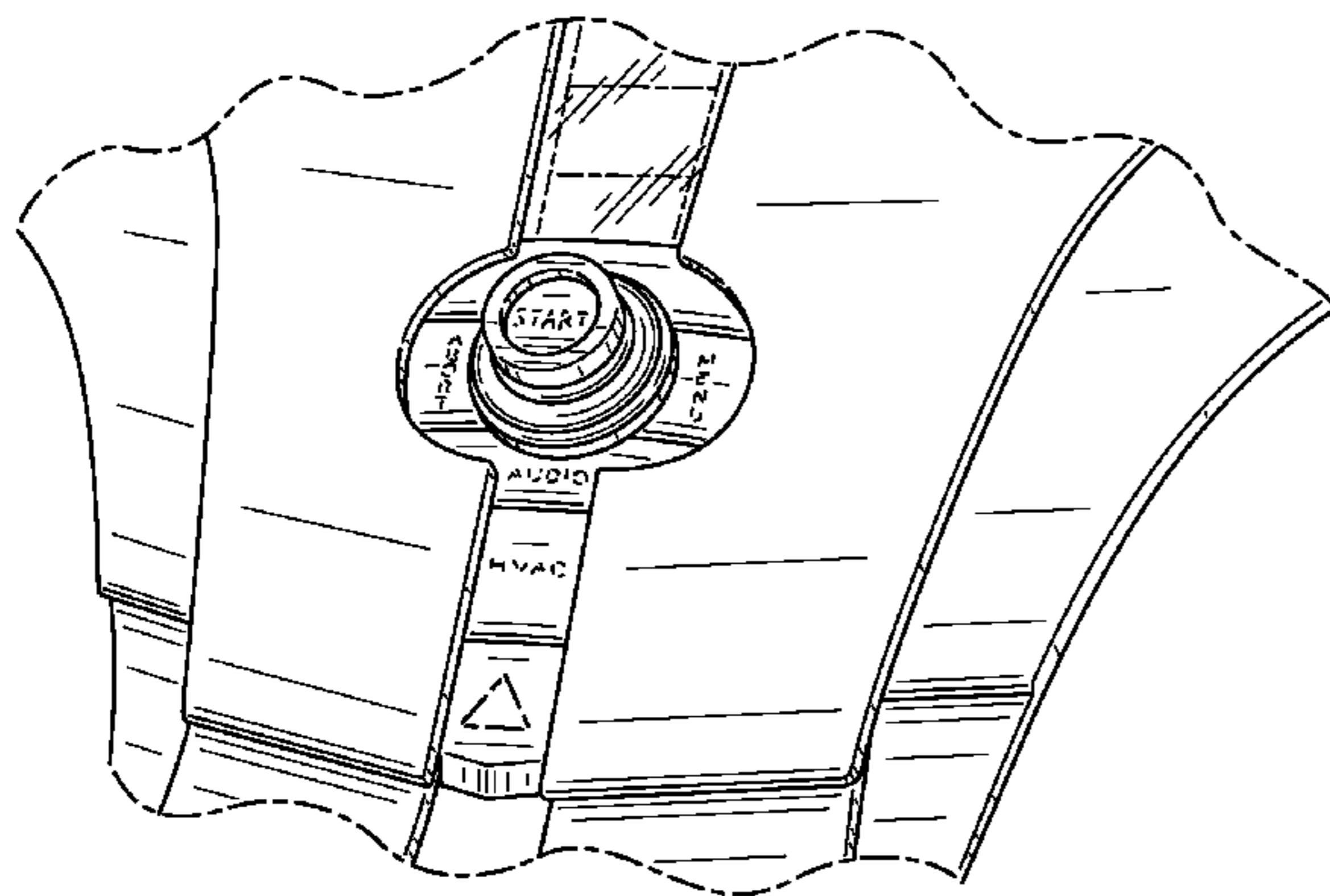

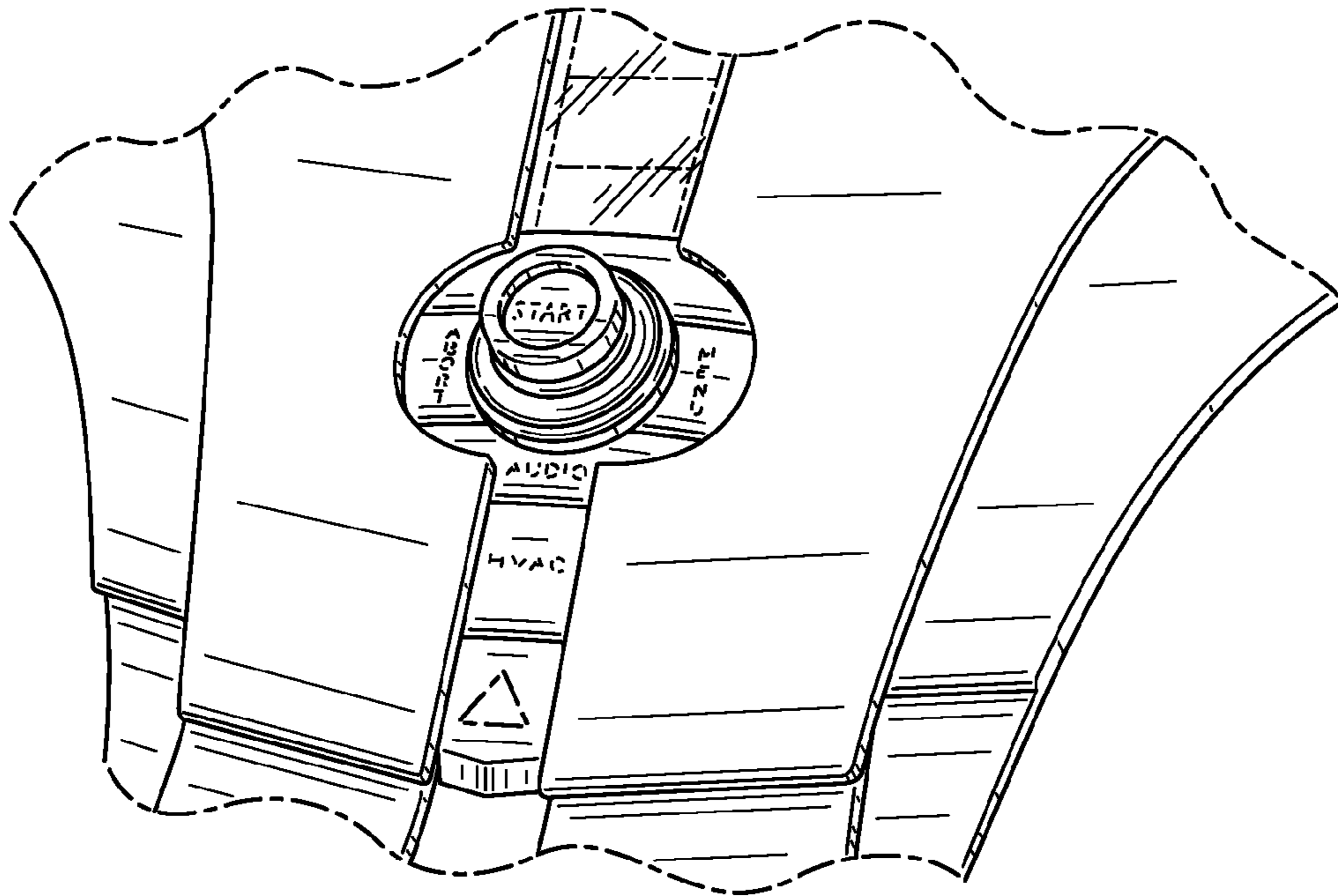

FIG. 1

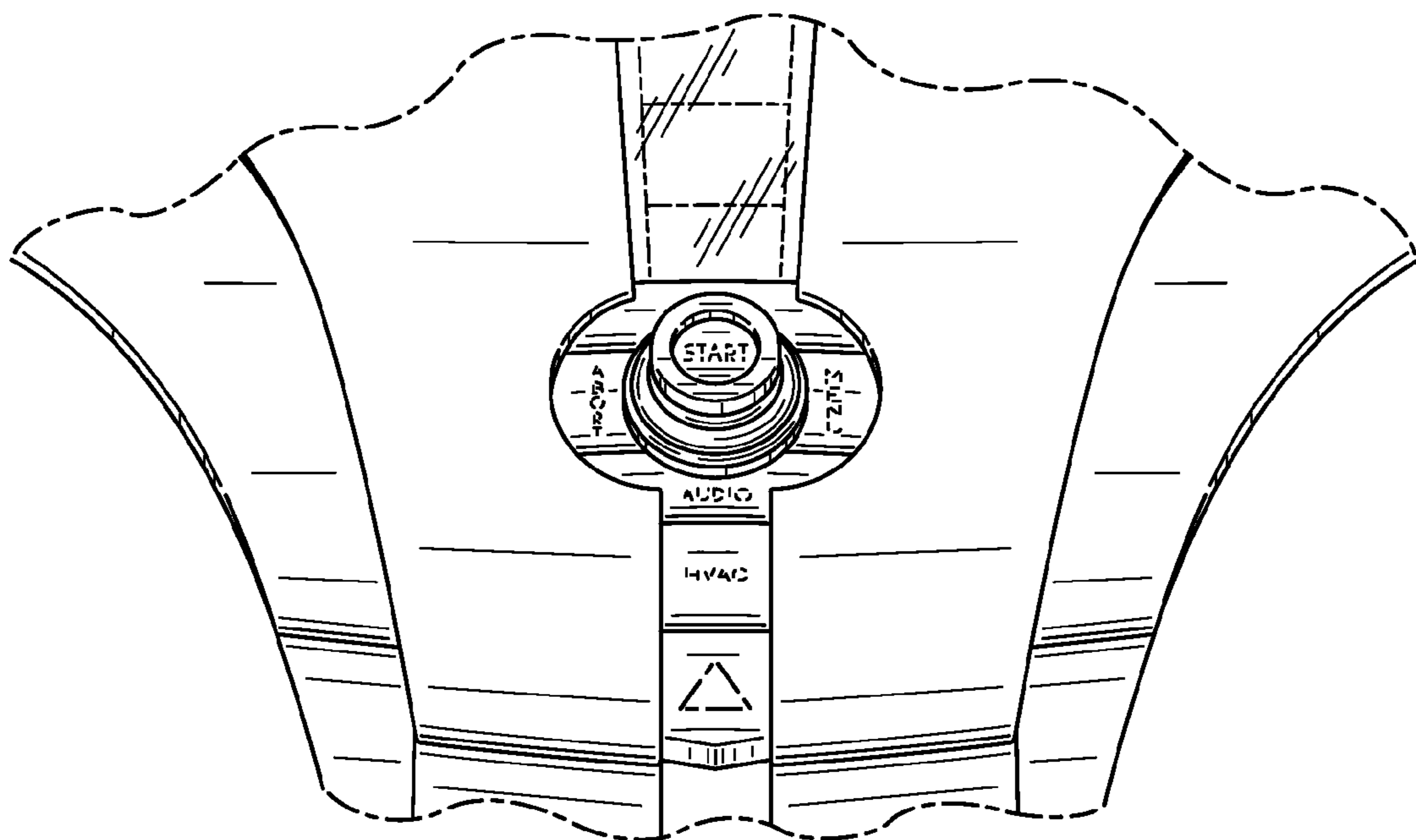

FIG. 2

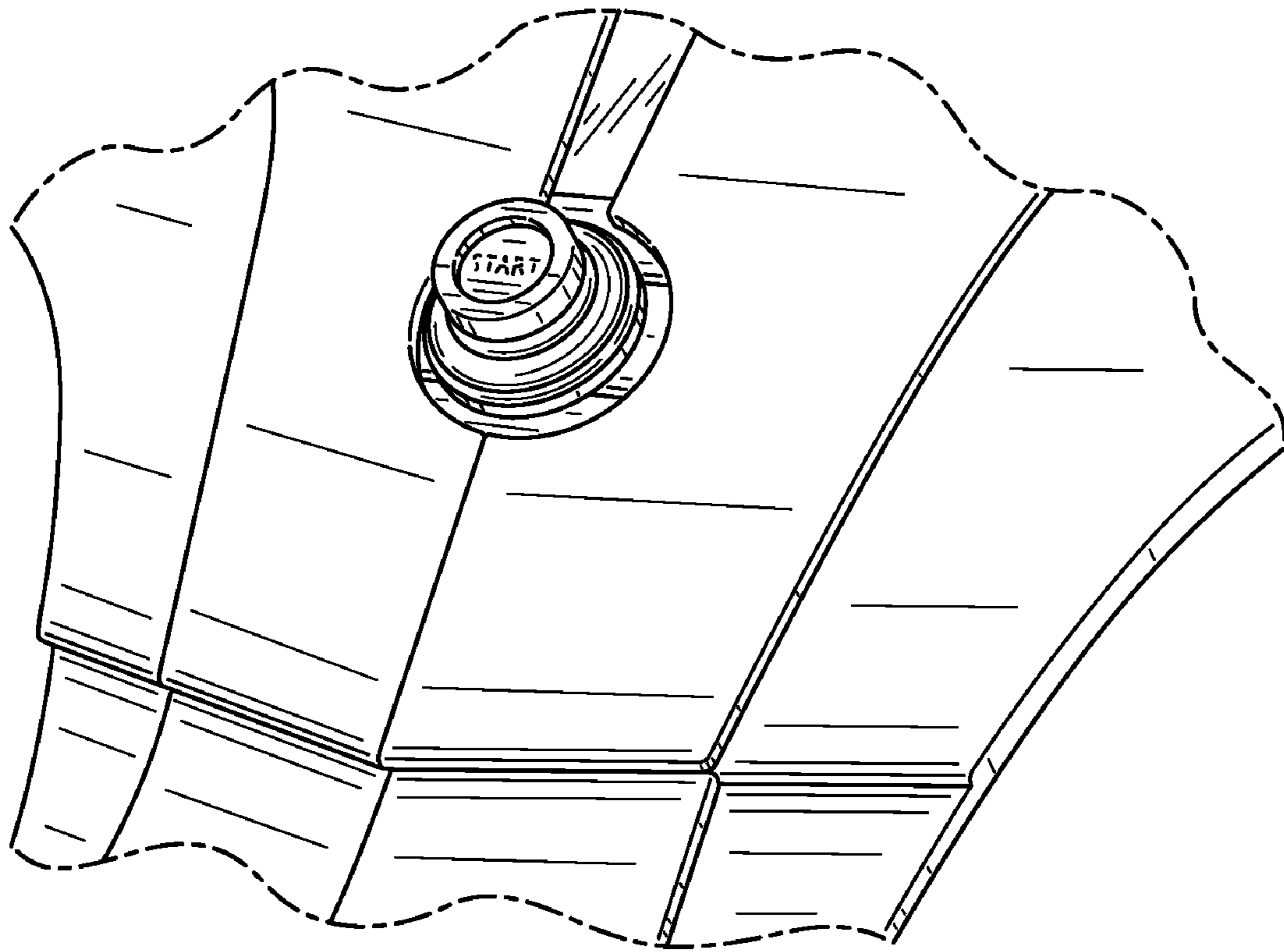

FIG. 3