



US00D567773S

(12) **United States Design Patent**
Kamada

(10) **Patent No.:** **US D567,773 S**
(45) **Date of Patent:** **** Apr. 29, 2008**

(54) **LIGHT EMITTING DIODE**

(75) Inventor: **Kazuhiro Kamada**, Tokushima (JP)

(73) Assignee: **Nichia Corporation**, Anan-shi (JP)

(**) Term: **14 Years**

(21) Appl. No.: **29/261,101**

(22) Filed: **Jun. 8, 2006**

(30) **Foreign Application Priority Data**

| | | | |
|---------------|------|-------|-------------|
| Jan. 31, 2006 | (JP) | | 2006-001918 |
| Jan. 31, 2006 | (JP) | | 2006-001920 |
| Jan. 31, 2006 | (JP) | | 2006-001921 |
| Jan. 31, 2006 | (JP) | | 2006-001922 |
| Jan. 31, 2006 | (JP) | | 2006-001923 |

(51) **LOC (8) Cl.** **13-03**

(52) **U.S. Cl.** **D13/180**

(58) **Field of Classification Search** D13/180;
D26/2; 257/79, 80, 81, 88, 89, 95, 98, 99,
257/100; 313/483, 498, 500; 362/555, 800
See application file for complete search history.

(56) **References Cited**

U.S. PATENT DOCUMENTS

| | | | | | |
|--------------|------|---------|-----------------|-------|---------|
| D477,580 | S * | 7/2003 | Kamada | | D13/182 |
| D503,690 | S * | 4/2005 | Kamada | | D13/180 |
| D523,826 | S * | 6/2006 | Kamada | | D13/180 |
| 7,078,728 | B2 * | 7/2006 | Ishii et al. | | 257/79 |
| 7,081,644 | B2 * | 7/2006 | Flaherty et al. | | 257/98 |
| D534,504 | S * | 1/2007 | Kim et al. | | D13/180 |
| D542,743 | S * | 5/2007 | Jung et al. | | D13/180 |
| 2004/0041222 | A1 * | 3/2004 | Loh | | 257/433 |
| 2004/0126913 | A1 * | 7/2004 | Loh | | 438/26 |
| 2006/0267036 | A1 * | 11/2006 | Lee et al. | | 257/98 |
| 2007/0029570 | A1 * | 2/2007 | Shin et al. | | 257/99 |
| 2007/0063321 | A1 * | 3/2007 | Han et al. | | 257/675 |
| 2007/0114559 | A1 * | 5/2007 | Sayers et al. | | 257/100 |

FOREIGN PATENT DOCUMENTS

JP 1225893 S 12/2004

KR 30-0400598 12/2005

* cited by examiner

Primary Examiner—Selina Sikder

(74) *Attorney, Agent, or Firm*—Global IP Counselors, LLP

(57) **CLAIM**

The ornamental design for a light emitting diode, as shown and described.

DESCRIPTION

FIG. 1 is a front top side perspective view of a light emitting diode in accordance with a first embodiment of my new design;

FIG. 2 is a front bottom side perspective view of the light emitting diode in accordance with the first embodiment of my new design;

FIG. 3 is a rear side perspective view of the light emitting diode in accordance with the first embodiment of my new design;

FIG. 4 is a front elevational view of the light emitting diode in accordance with the first embodiment of my new design;

FIG. 5 is a rear elevational view of the light emitting diode in accordance with the first embodiment of my new design;

FIG. 6 is a top plan view of the light emitting diode in accordance with the first embodiment of my new design;

FIG. 7 is a bottom plan view of the light emitting diode in accordance with the first embodiment of my new design;

FIG. 8 is a right side end elevational view of the light emitting diode in accordance with the first embodiment of my new design;

FIG. 9 is a left side end elevational view of the light emitting diode in accordance with the first embodiment of my new design;

FIG. 10 is a front elevational view of the light emitting diode in accordance with the first embodiment of my new design with environment shown in broken lines;

FIG. 11 is a front top side perspective view of a light emitting diode in accordance with a second embodiment of my new design;

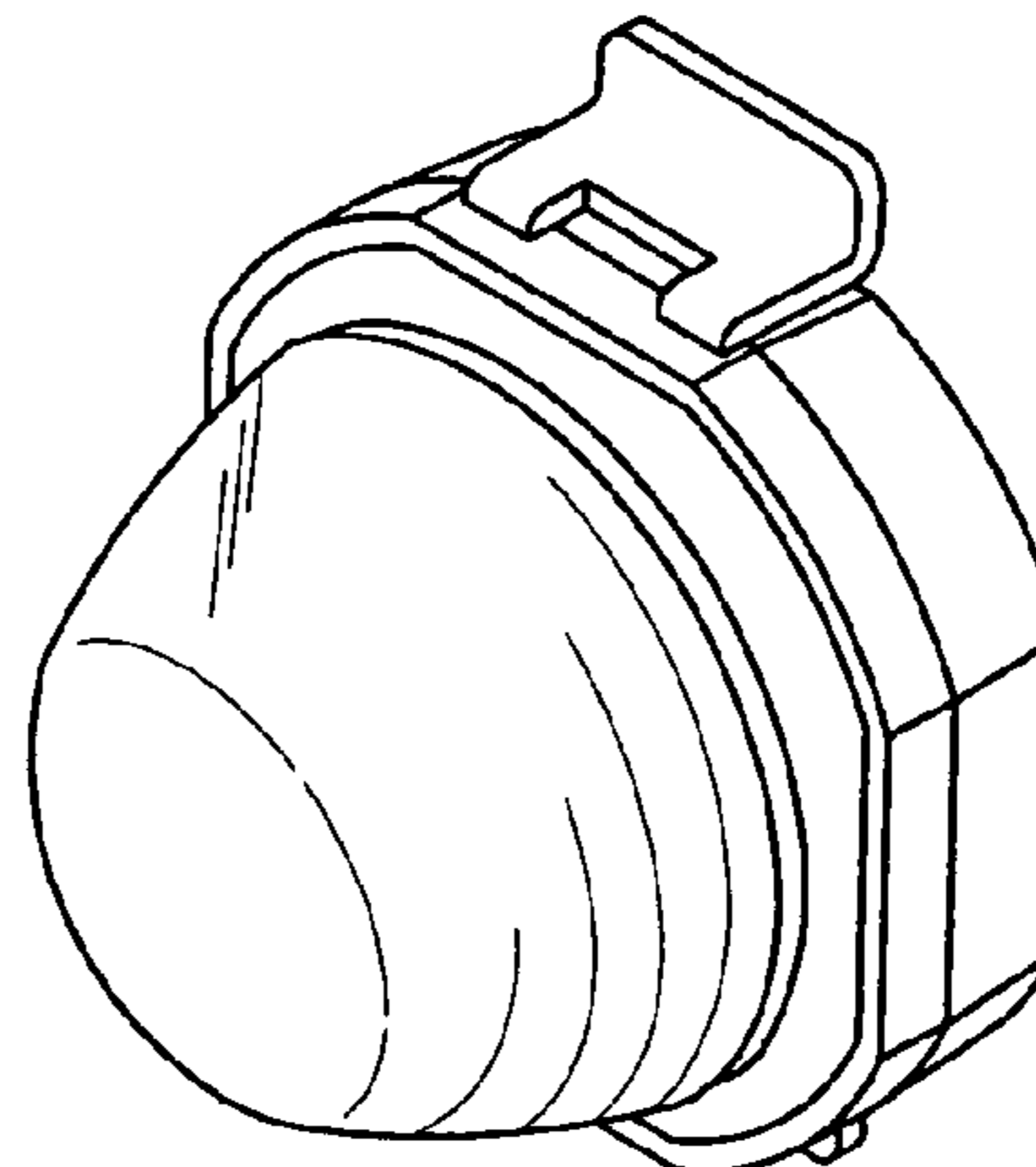
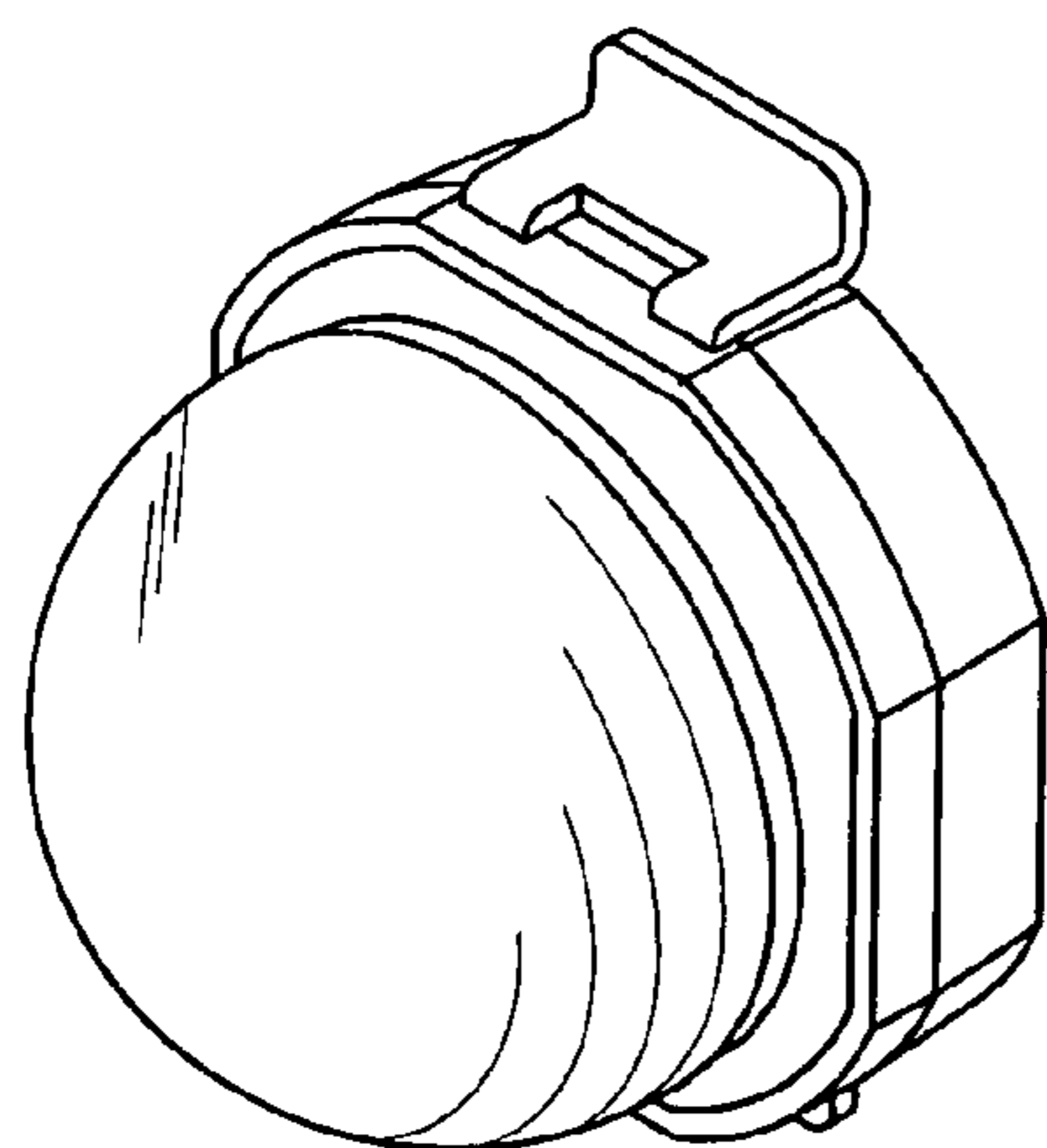

FIG. **12** is a front bottom side perspective view of the light emitting diode in accordance with the second embodiment of my new design;

FIG. **13** is a rear side perspective view of the light emitting diode in accordance with the second embodiment of my new design;

FIG. **14** is a front elevational view of the light emitting diode in accordance with the second embodiment of my new design;

FIG. **15** is a rear elevational view of the light emitting diode in accordance with the second embodiment of my new design;

FIG. **16** is a top plan view of the light emitting diode in accordance with the second embodiment of my new design;

FIG. **17** is a bottom plan view of the light emitting diode in accordance with the second embodiment of my new design;

FIG. **18** is a right side end elevational view of the light emitting diode in accordance with the second embodiment of my new design;

FIG. **19** is a left side end elevational view of the light emitting diode in accordance with the second embodiment of my new design; and,

FIG. **20** is a front elevational view of the light emitting diode in accordance with the second embodiment of my new design with environment shown in broken lines.

The broken line showing of environment (the remaining structure of the light emitting diode) in the Figures is for illustrative purposes only and forms no part of the claimed design.

The opaque line shading illustrates a translucent portion of the light emitting diode through which the environment shown in the broken lines may be visible as illustrated in FIGS. **10** and **20**.

1 Claim, 12 Drawing Sheets

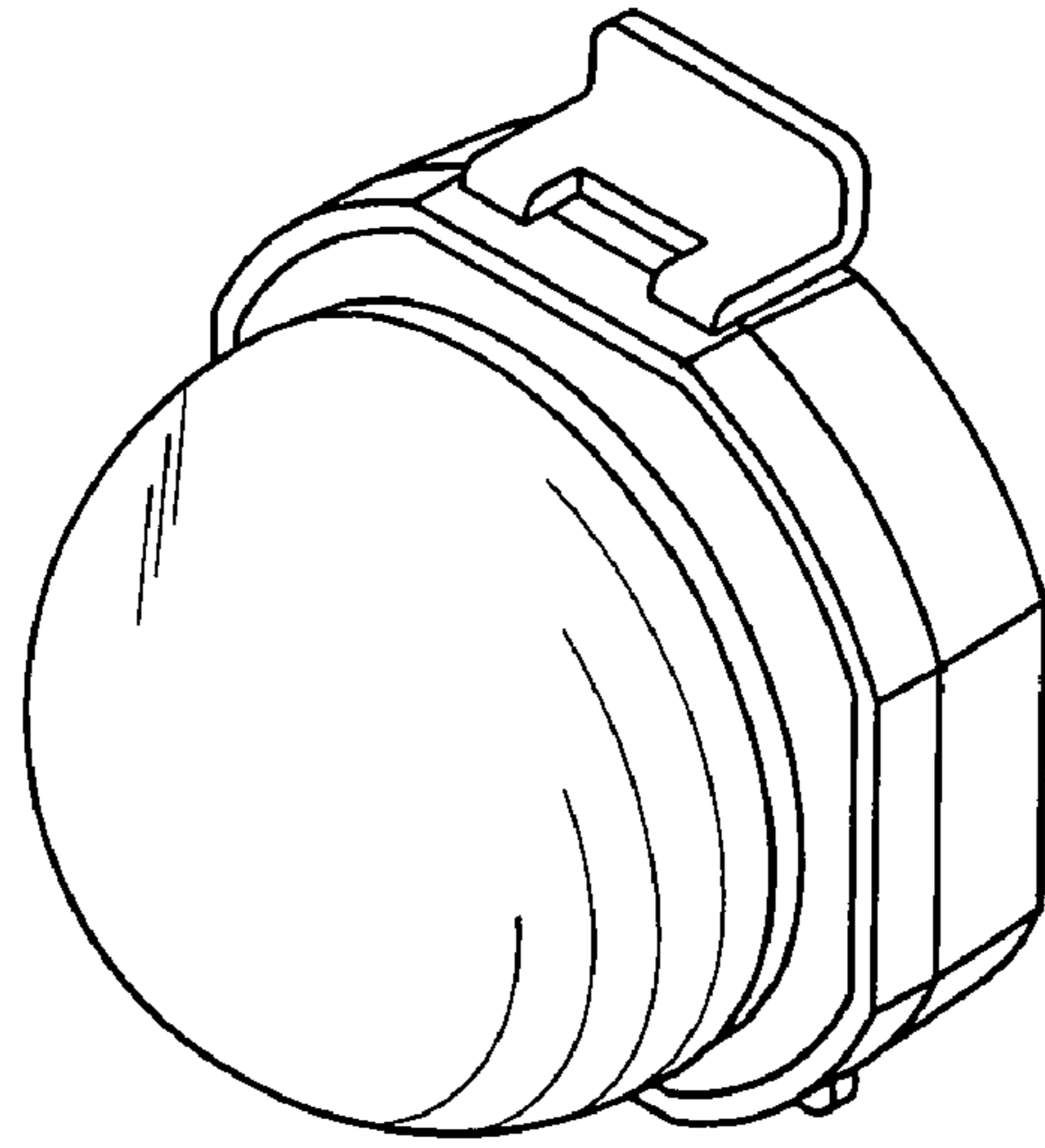

Fig. 1

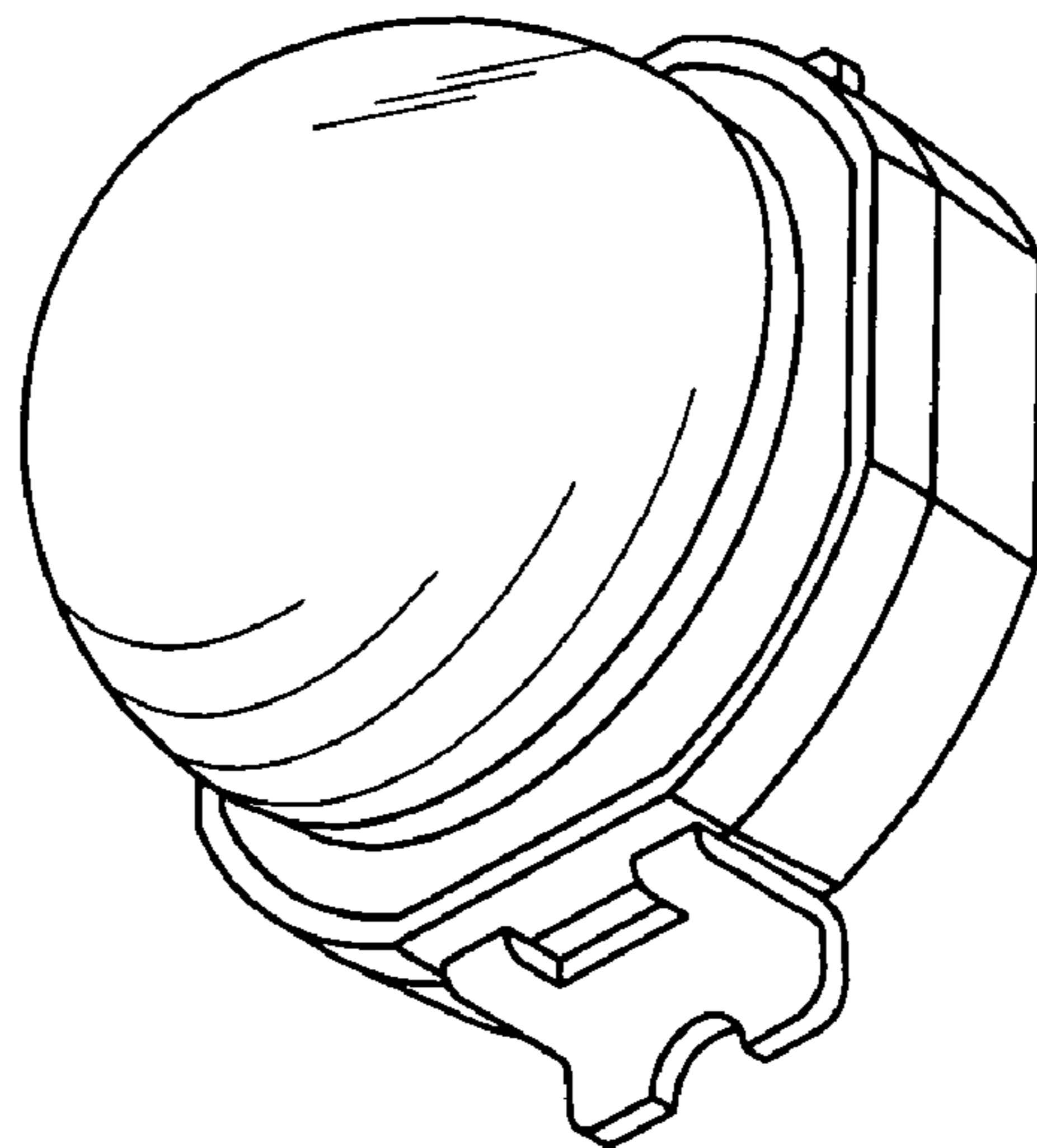

Fig. 2

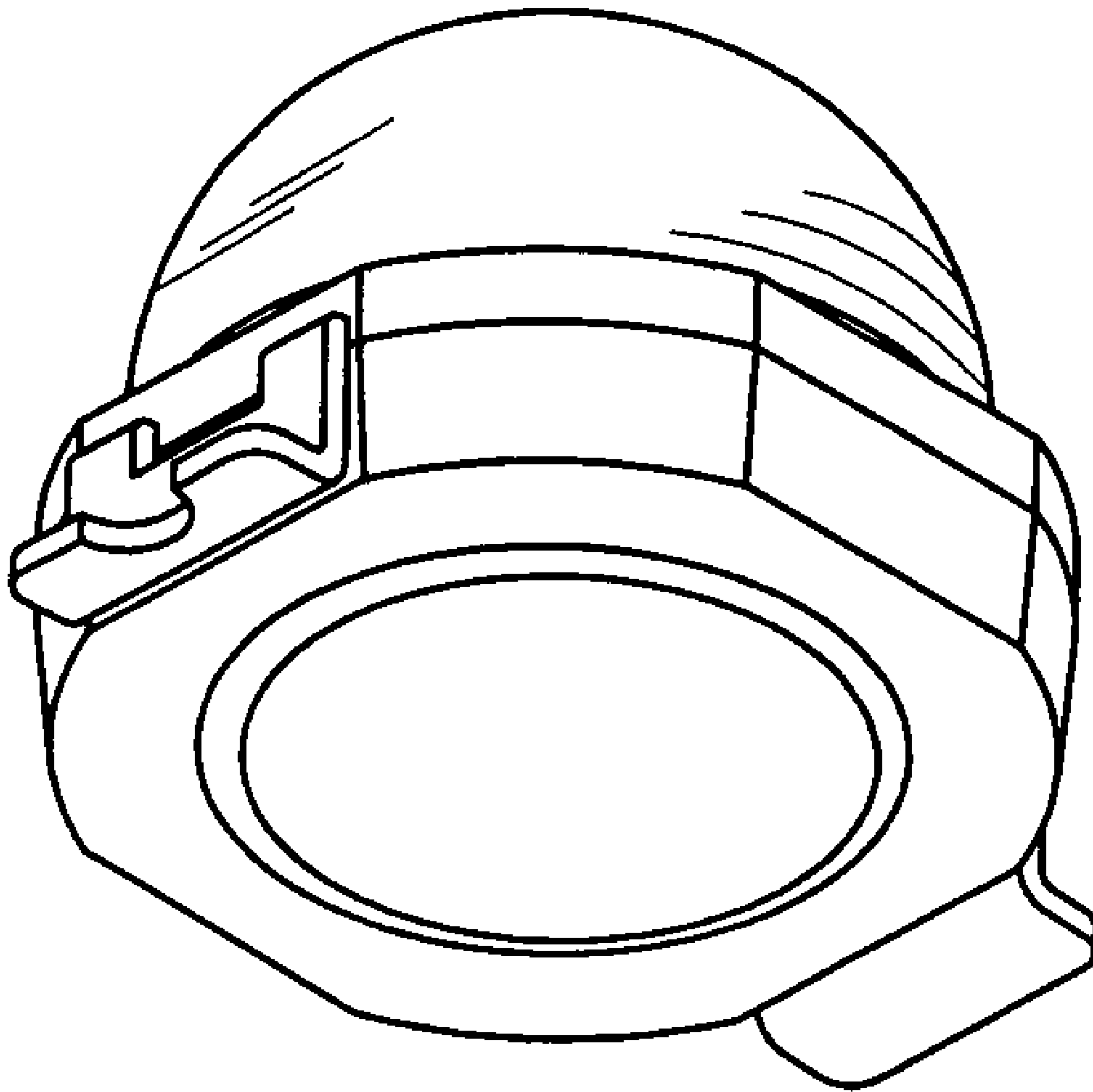

Fig. 3

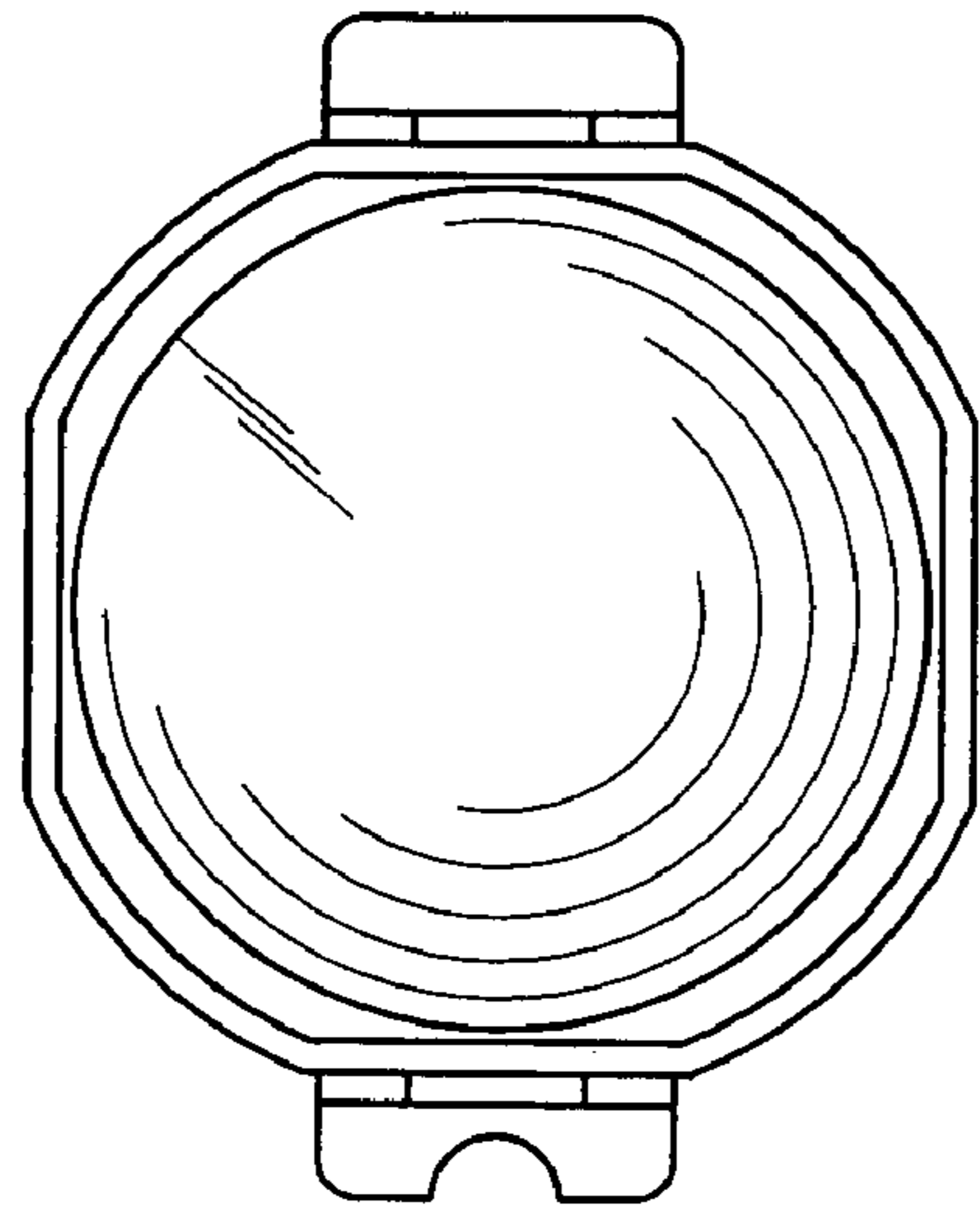

Fig. 4

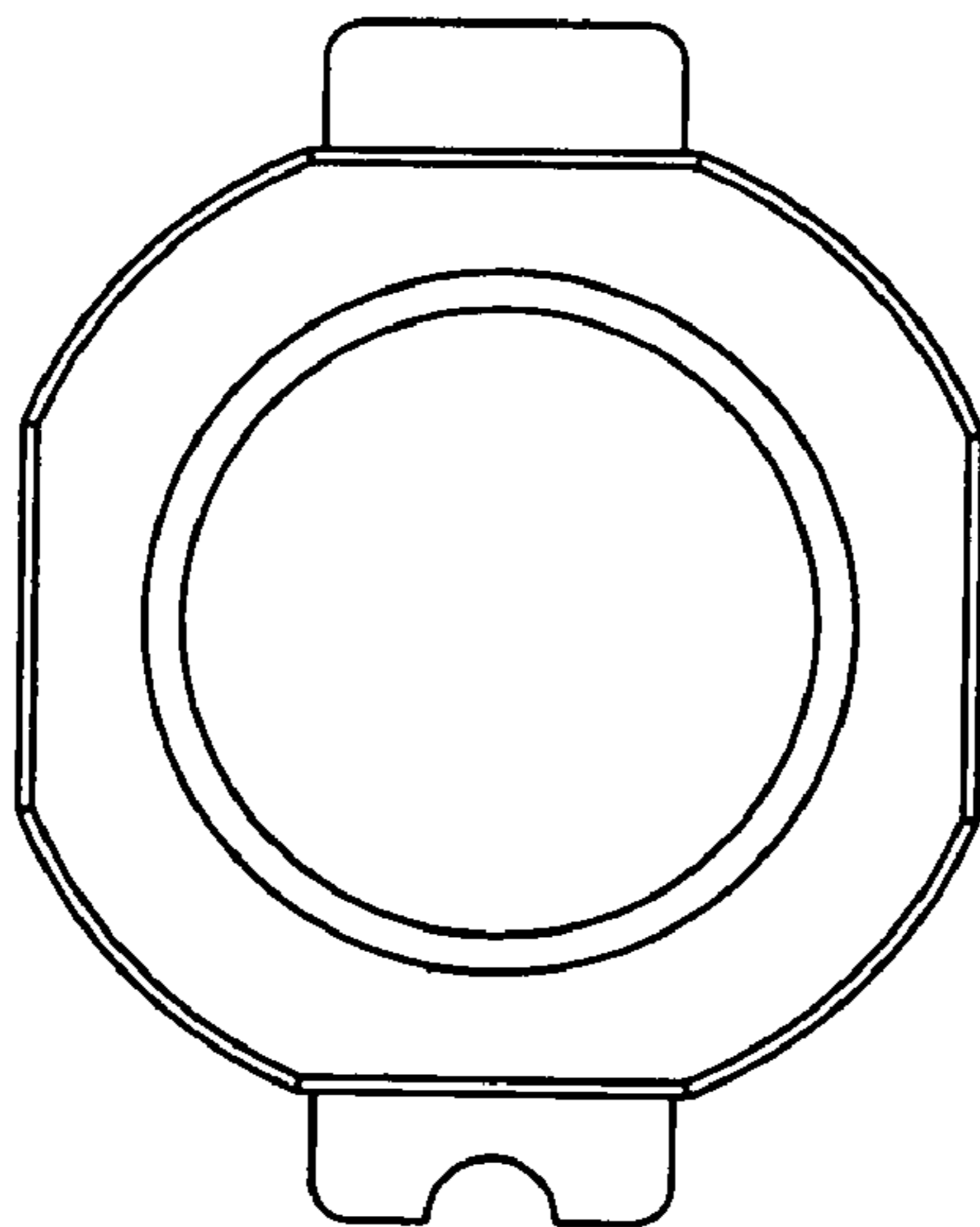

Fig. 5

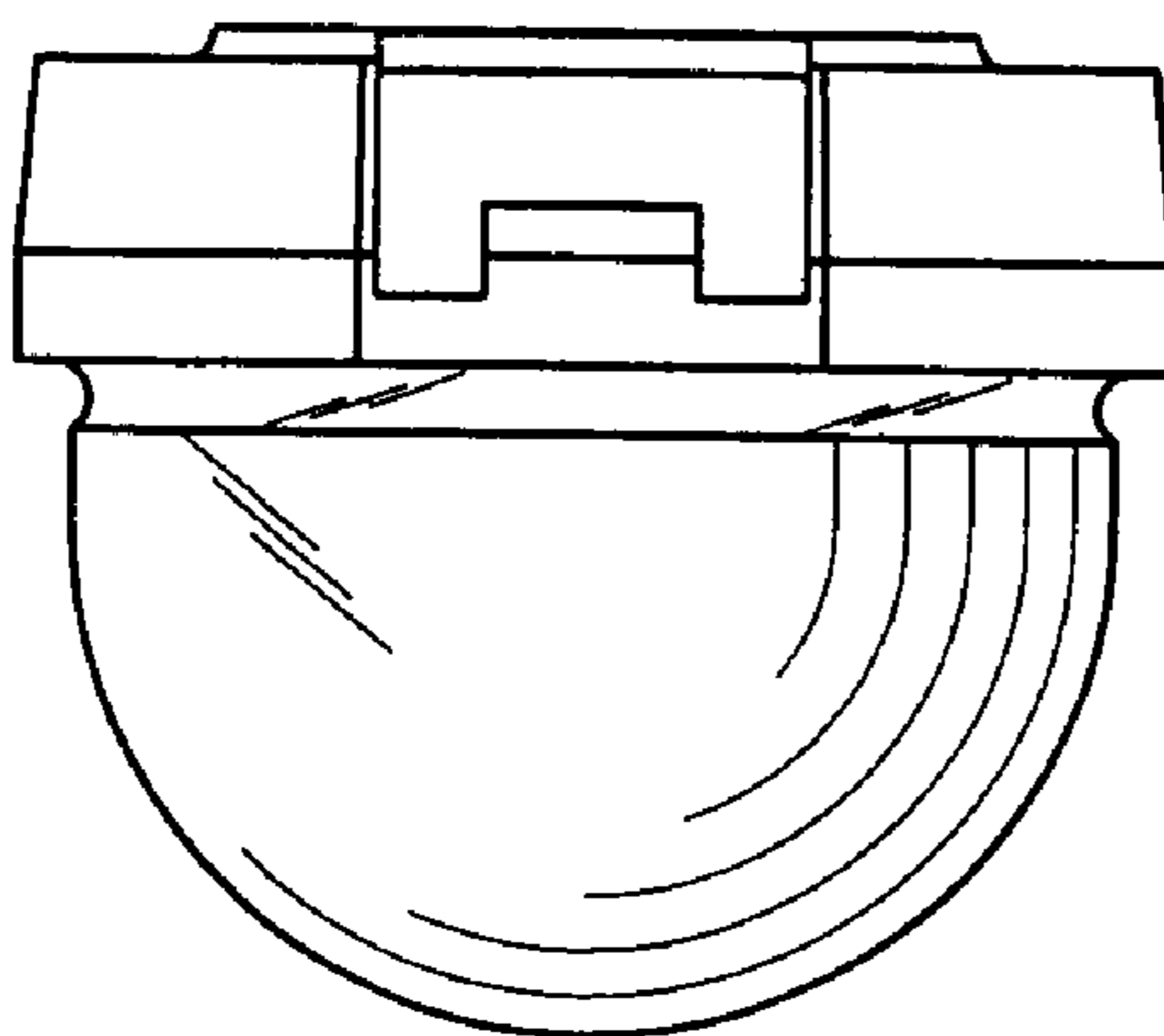

Fig. 6

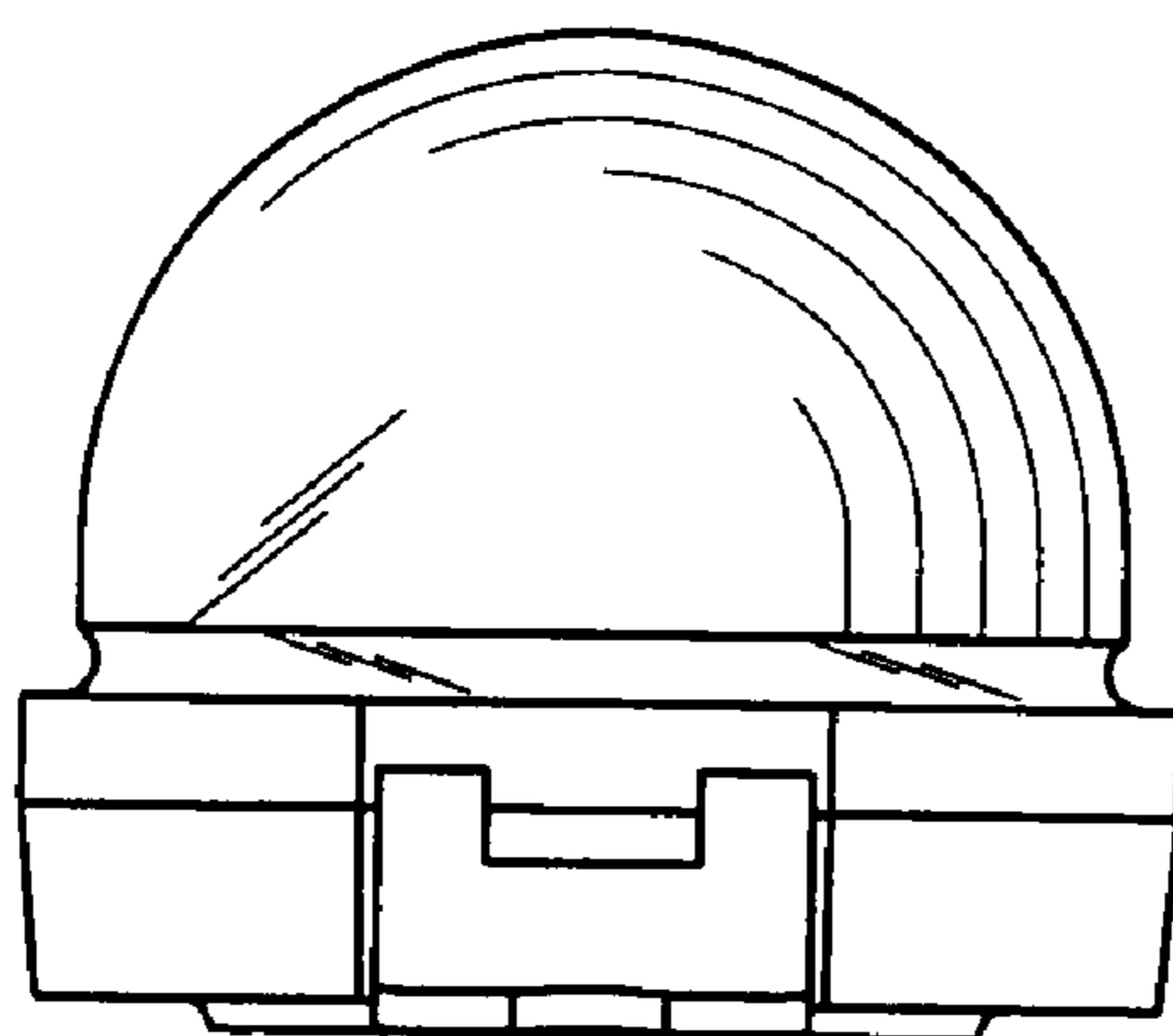

Fig. 7

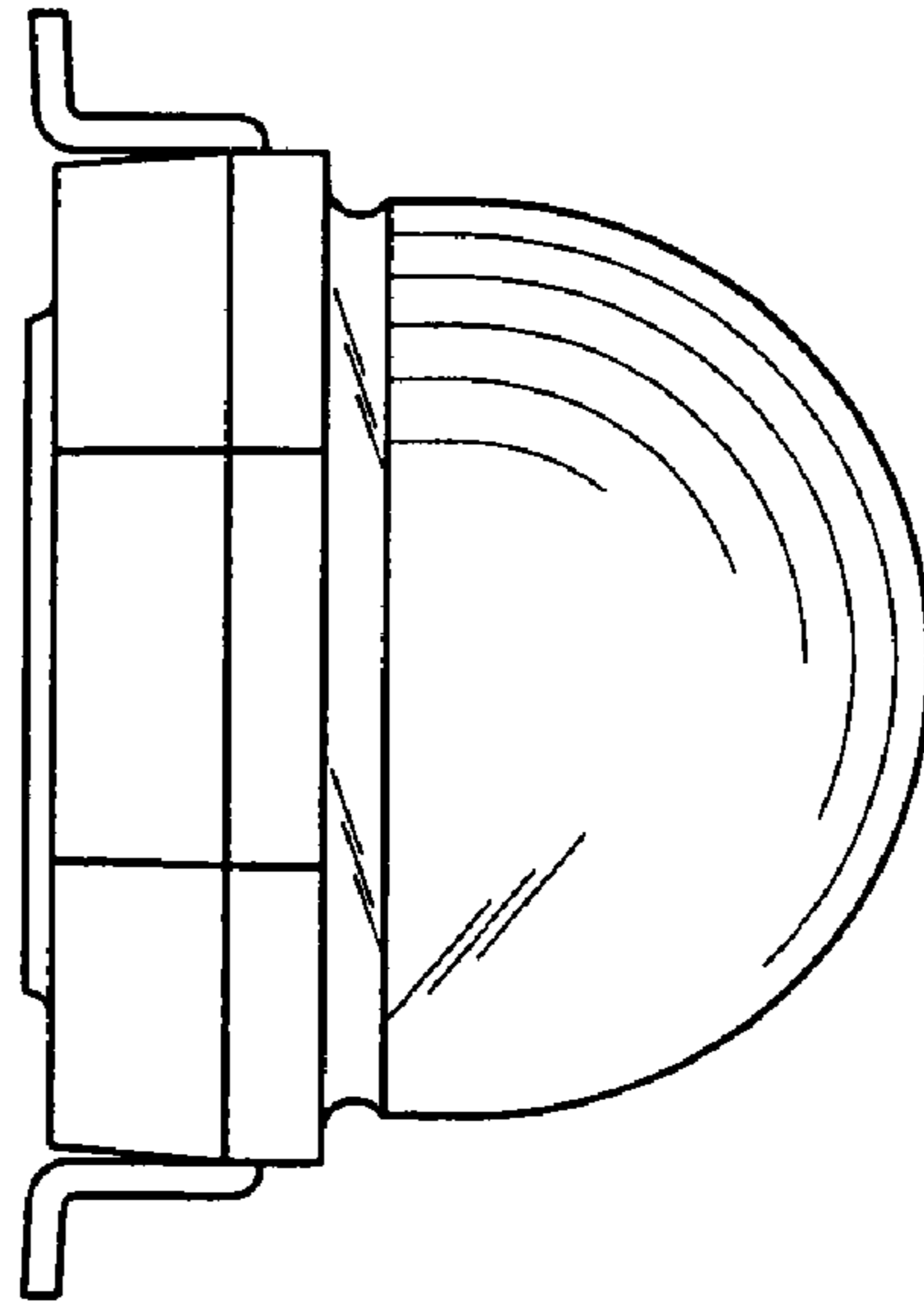

Fig. 8

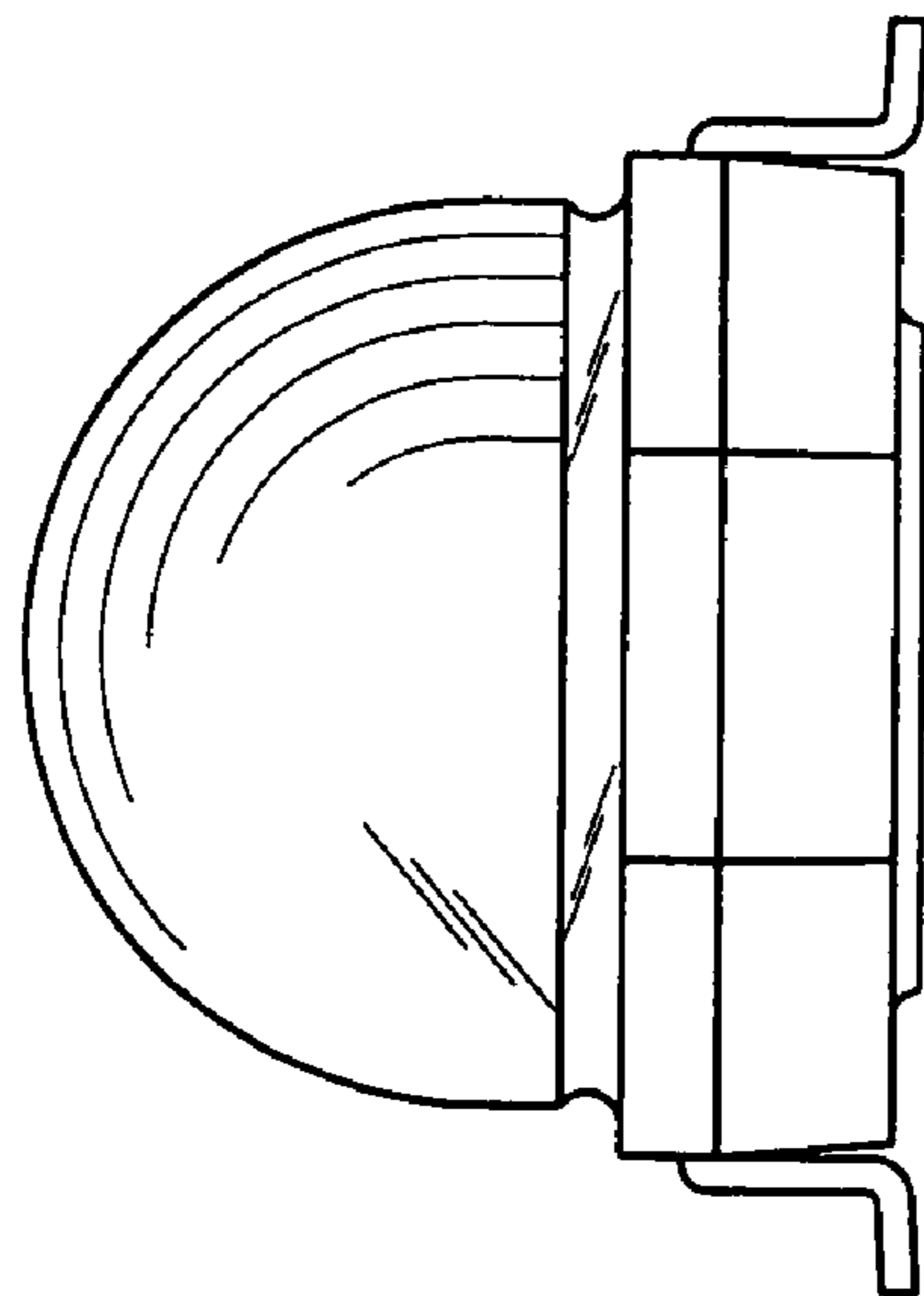

Fig. 9

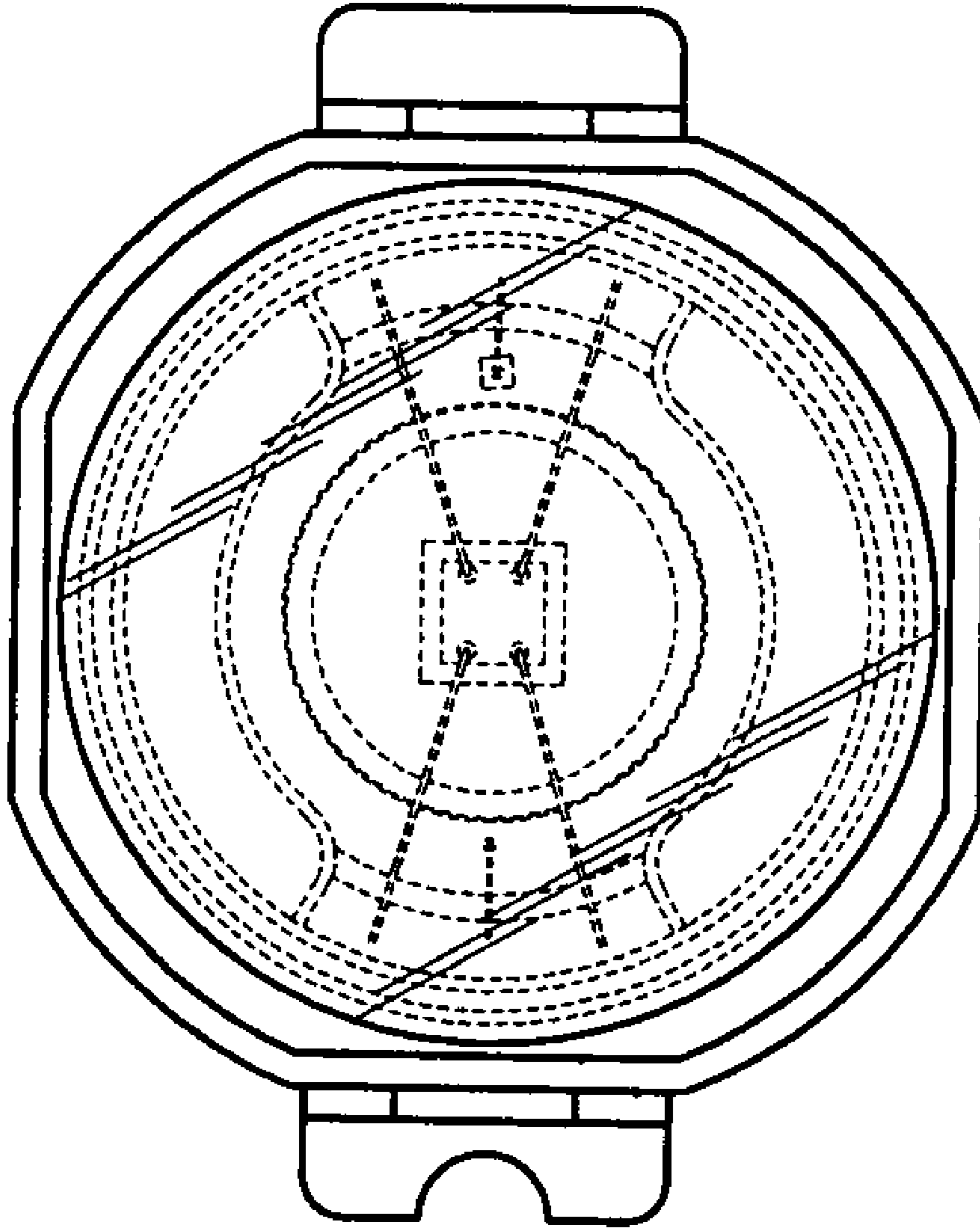

Fig. 10

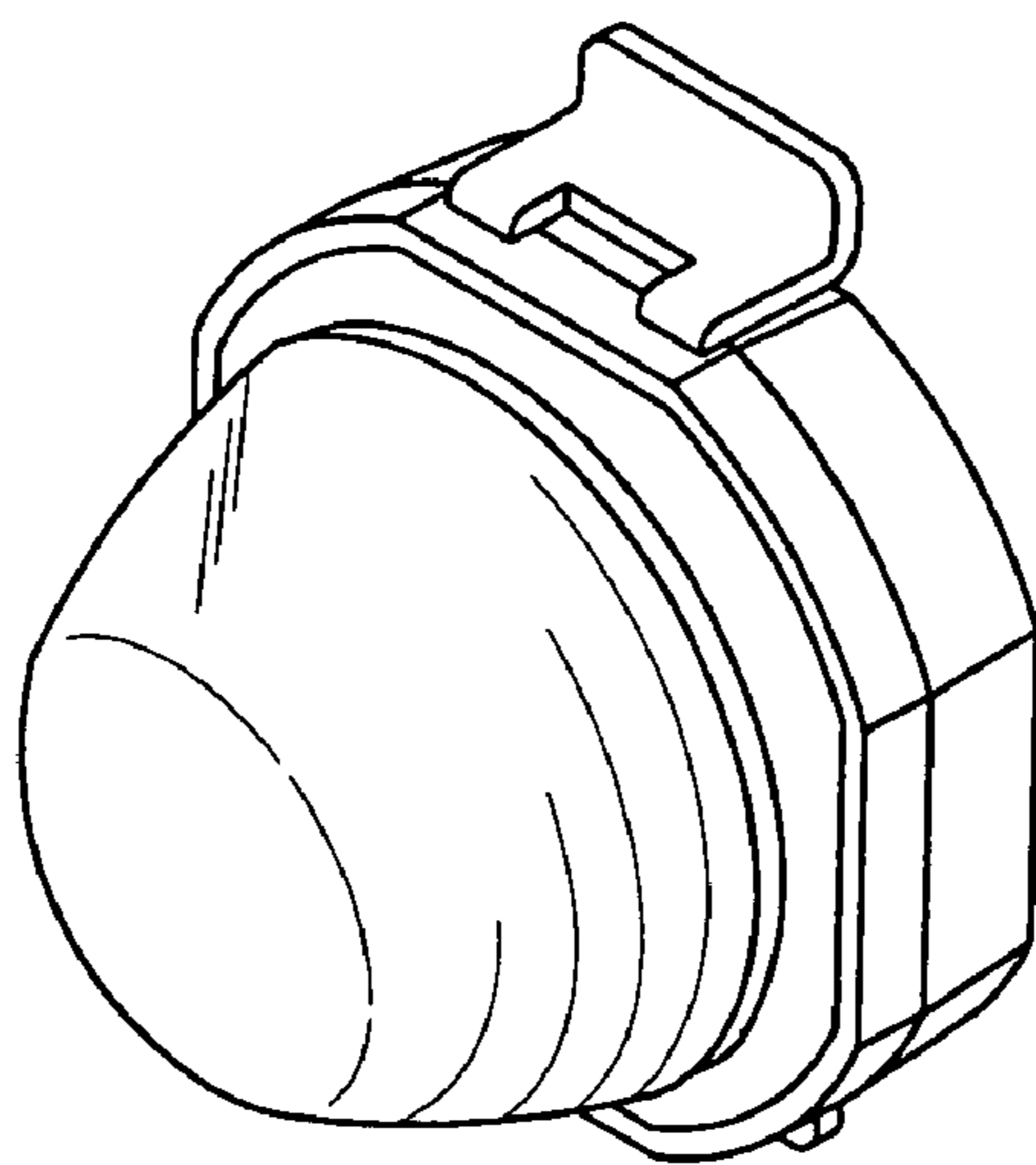

Fig. 11

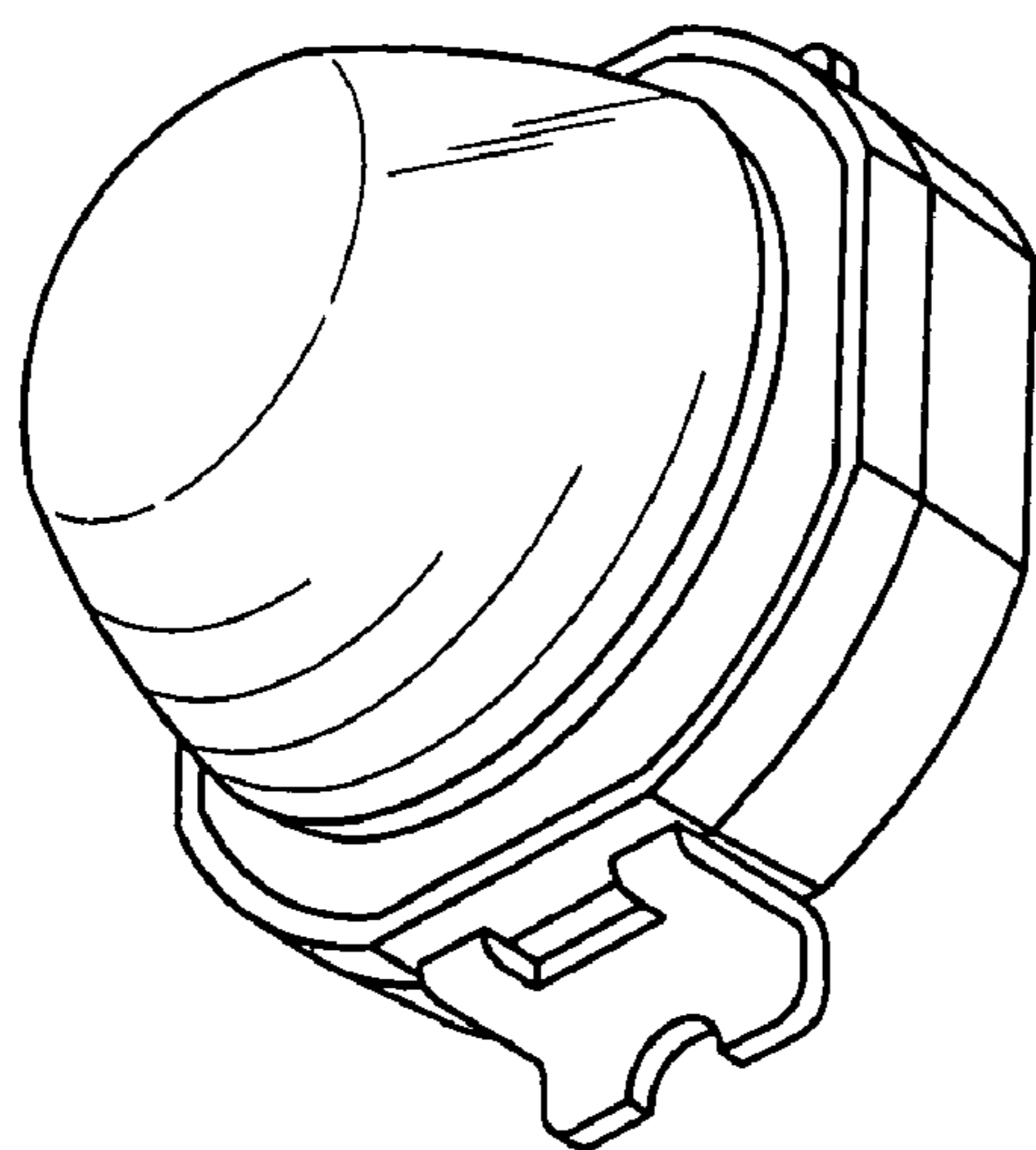

Fig. 12

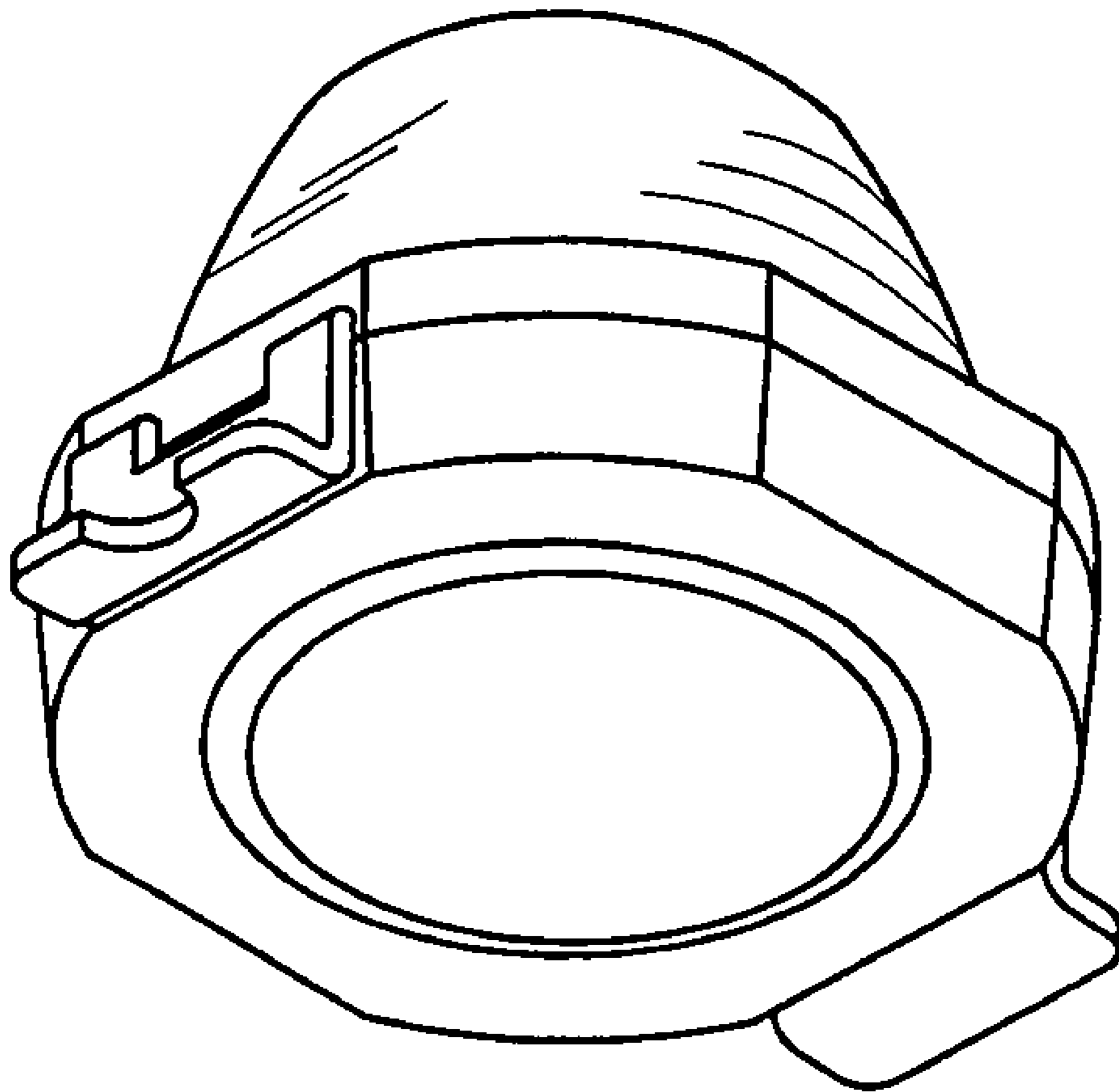

Fig. 13

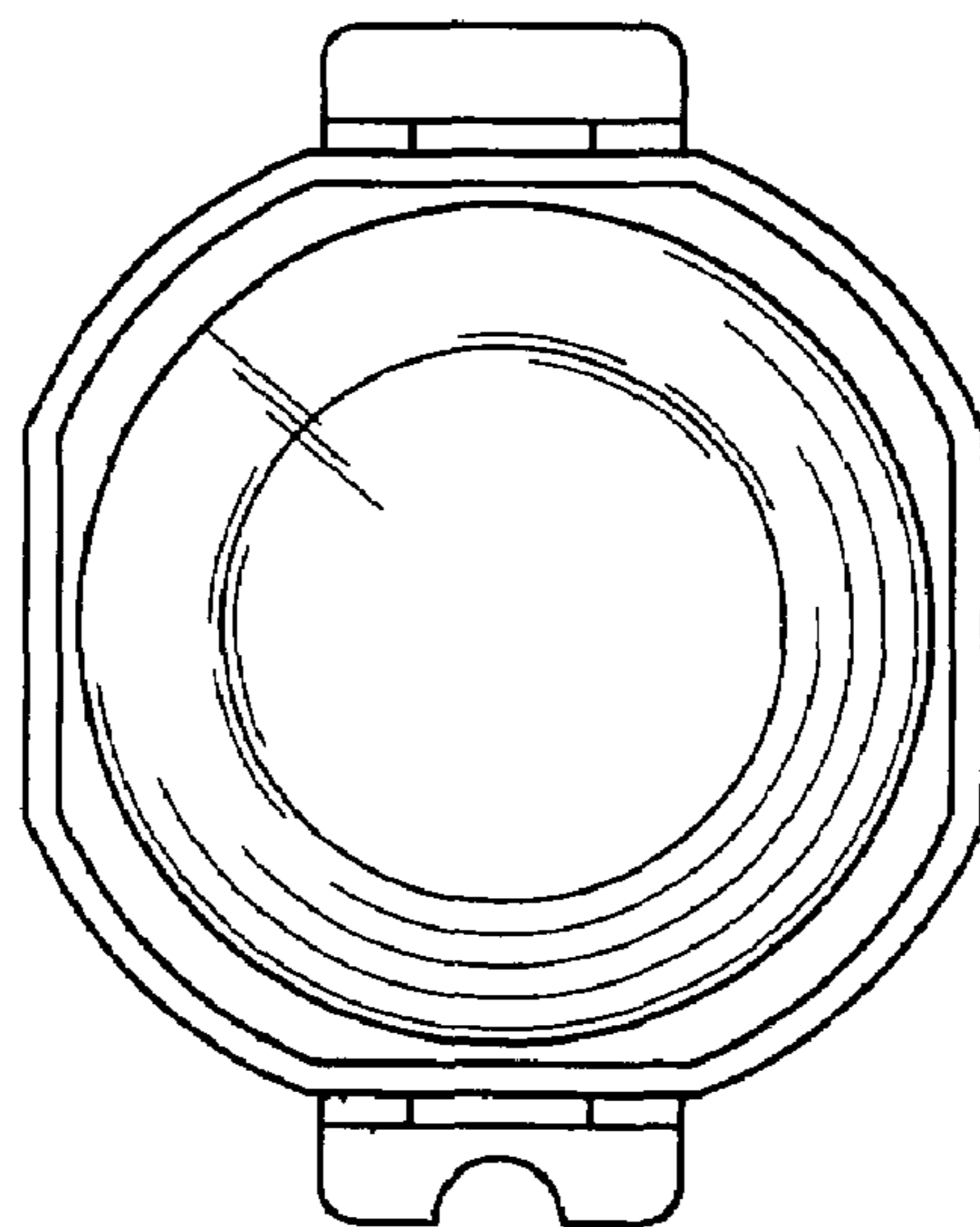

Fig. 14

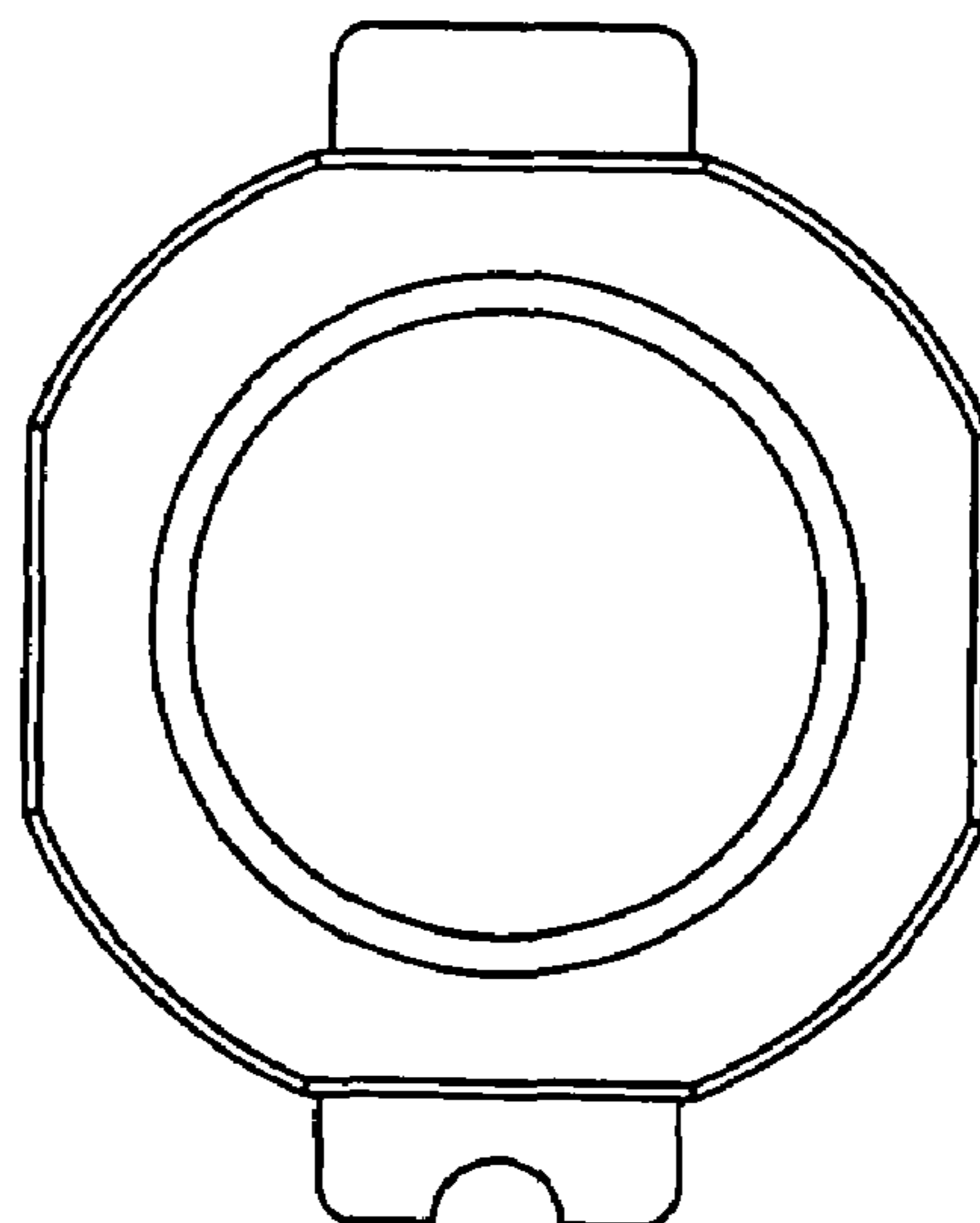

Fig. 15

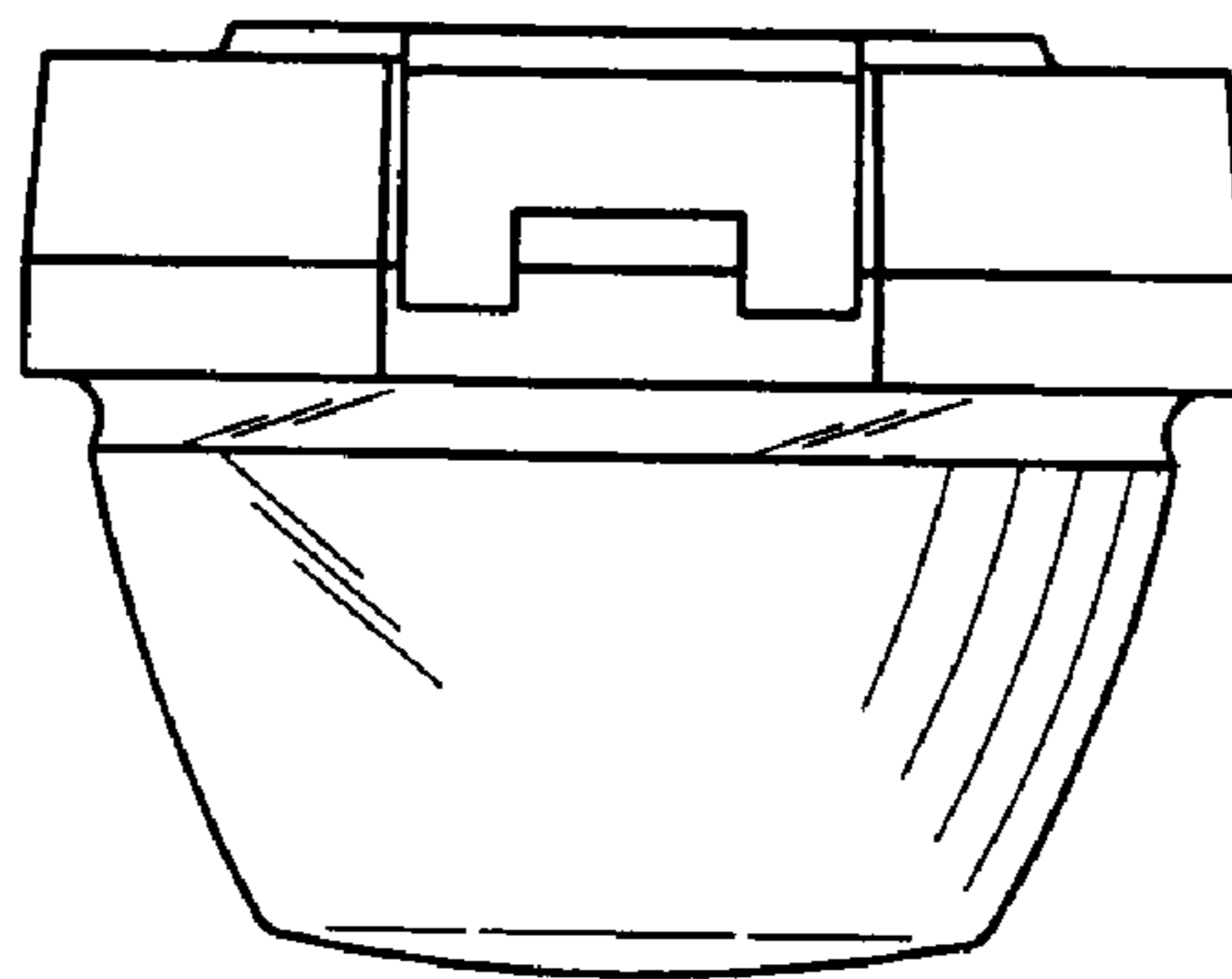

Fig. 16

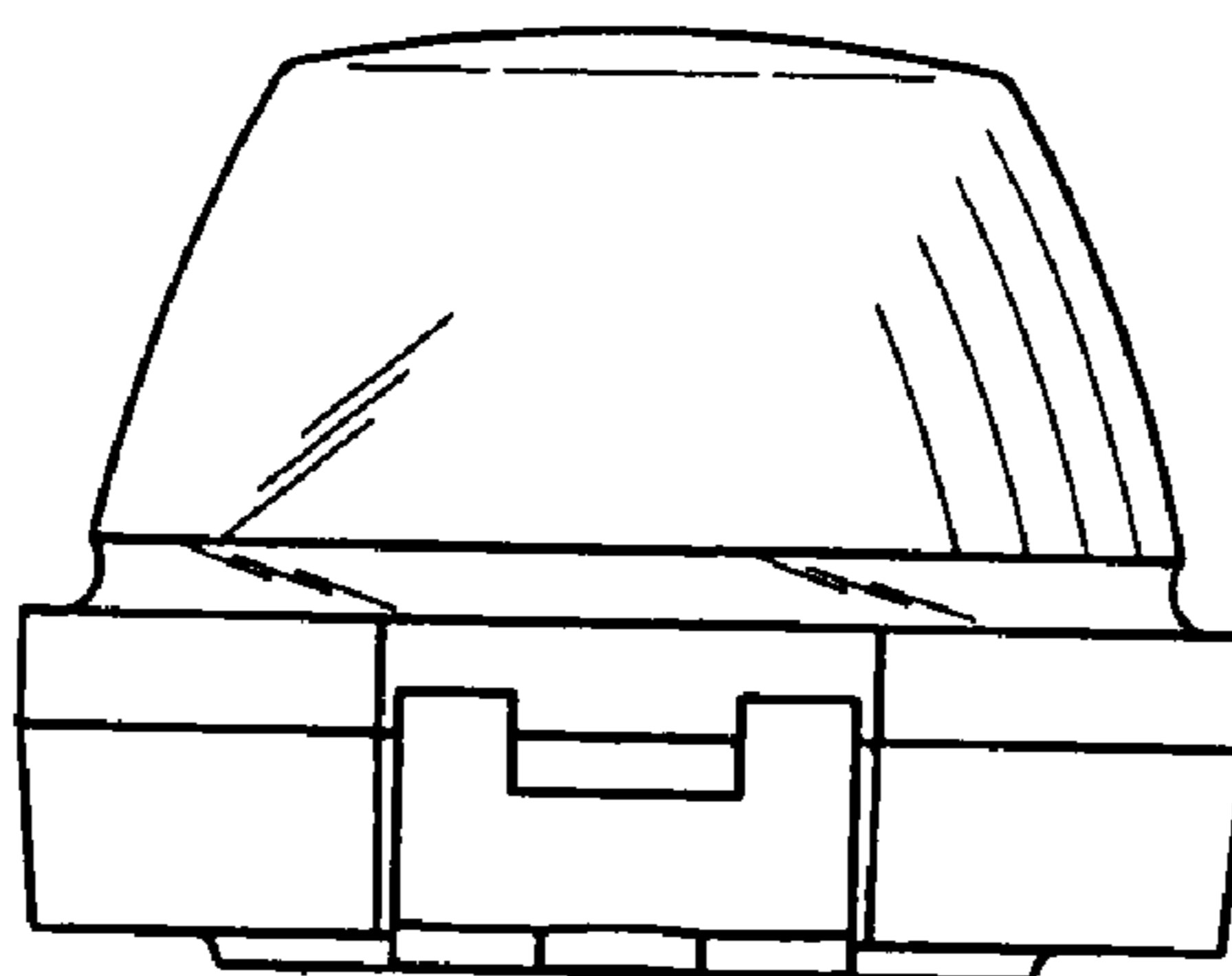

Fig. 17

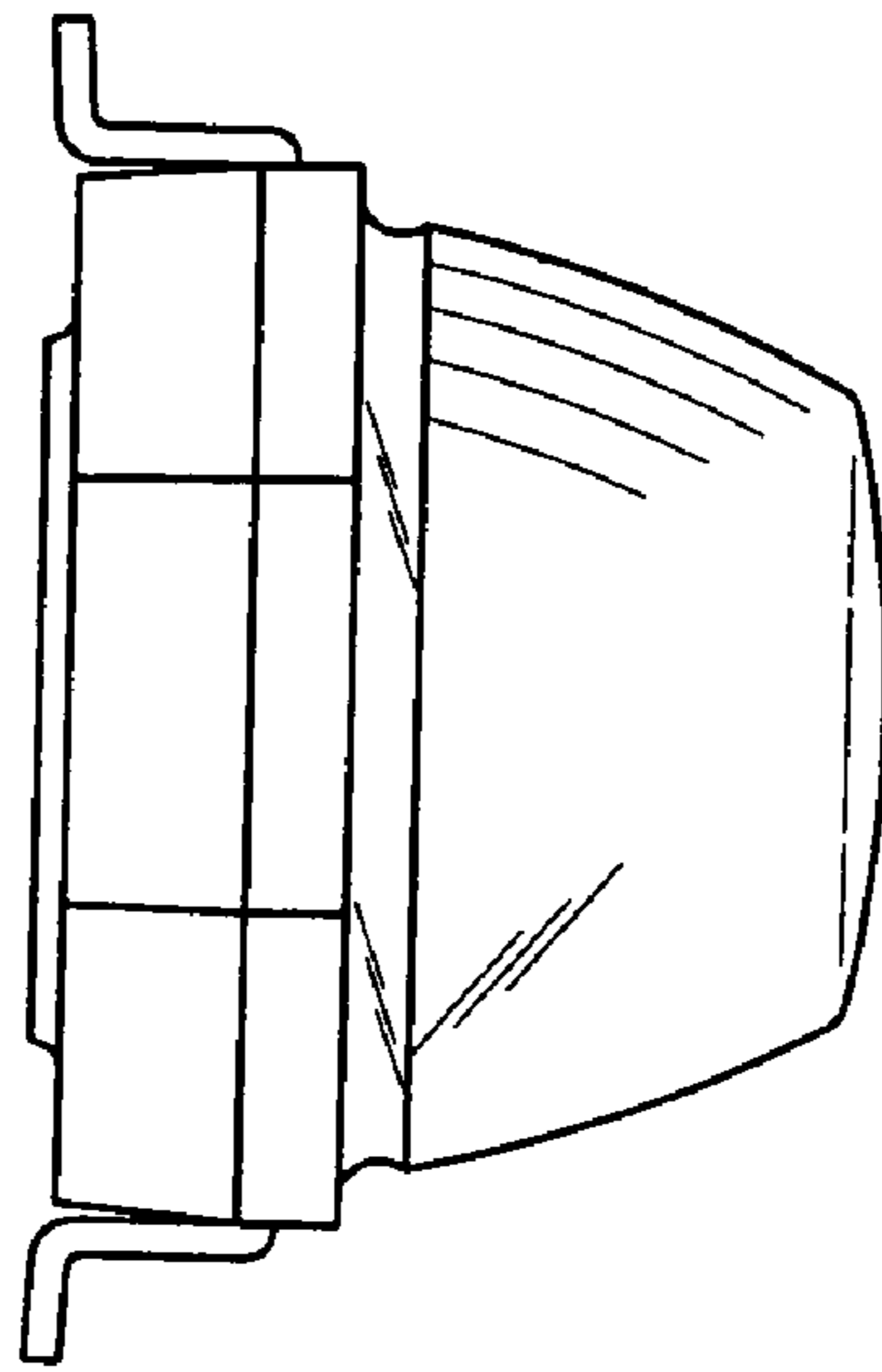

Fig. 18

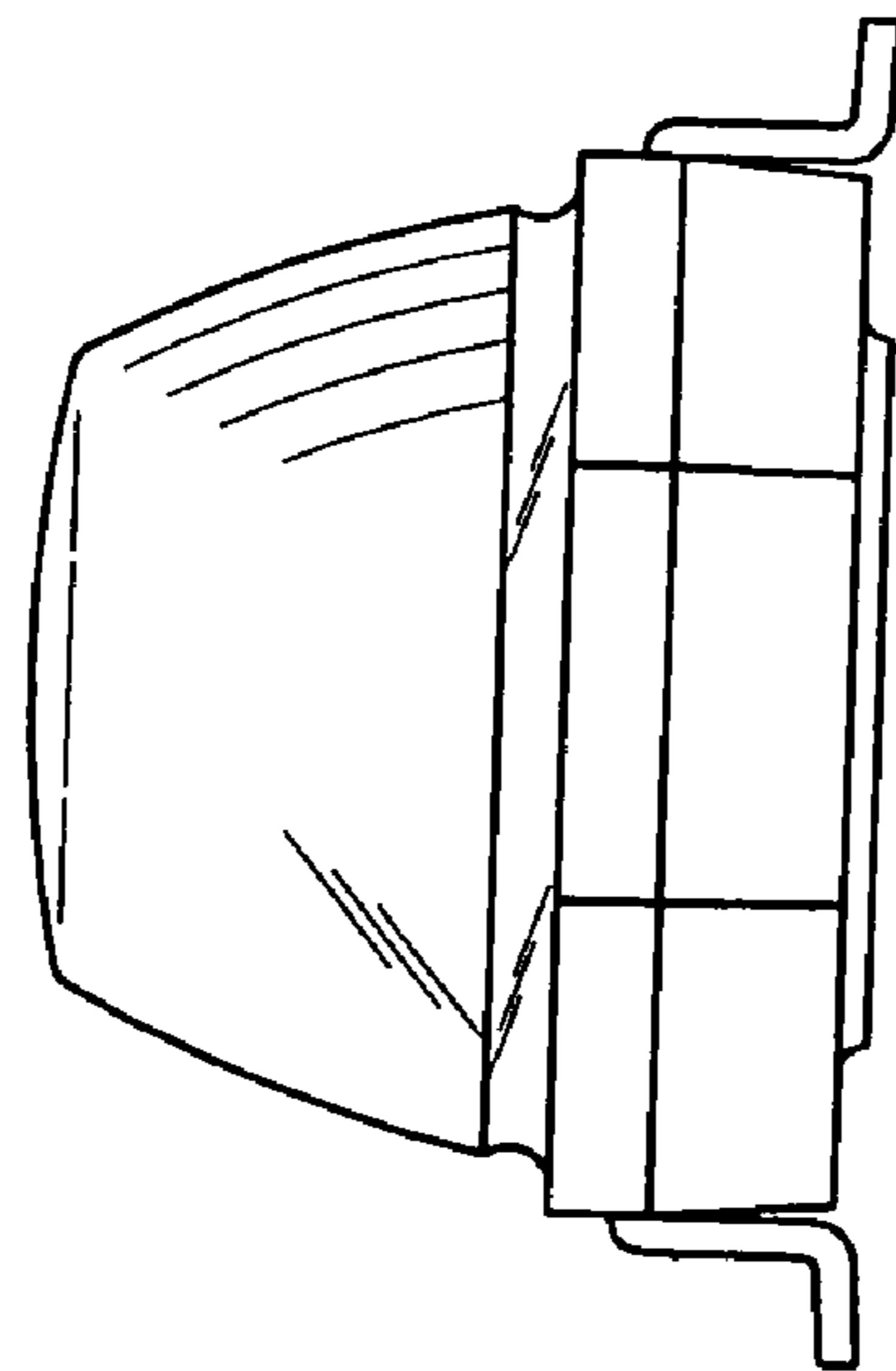

Fig. 19

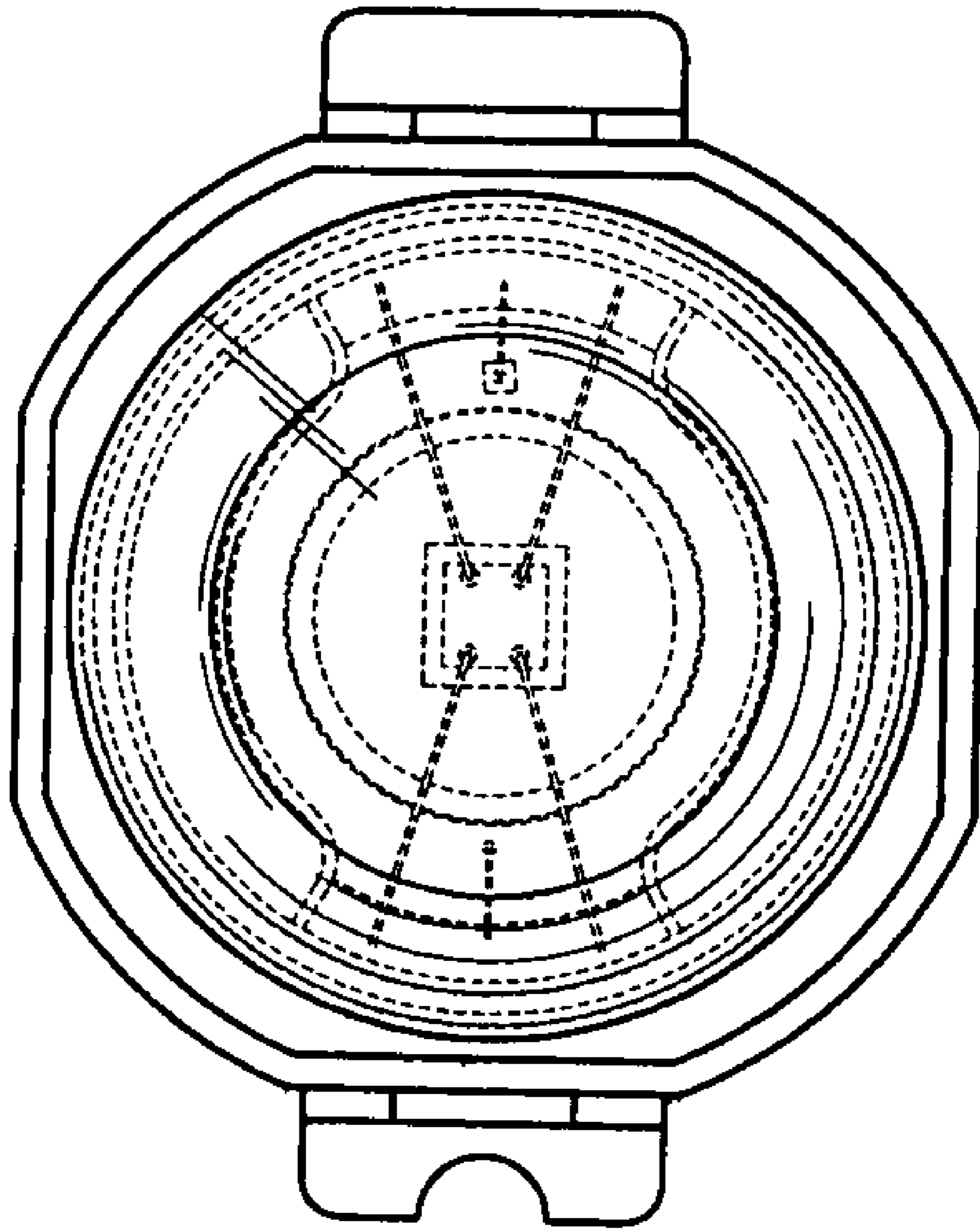

Fig. 20