



US00D567729S

(12) **United States Design Patent**
Crandall

(10) **Patent No.:** **US D567,729 S**

(45) **Date of Patent:** **** Apr. 29, 2008**

(54) **STEP RAIL FOR A VEHICLE**

(75) Inventor: **Robert T. Crandall**, Yorba Linda, CA
(US)

(73) Assignee: **Berryman Products, Inc.**, Arlington,
TX (US)

(**) Term: **14 Years**

(21) Appl. No.: **29/243,941**

(22) Filed: **Dec. 1, 2005**

(51) **LOC (8) Cl.** **12-16**

(52) **U.S. Cl.** **D12/203**

(58) **Field of Classification Search** D12/203,
D12/190; 280/163, 164.1, 166, 169, 607,
280/164.2, 165; 182/90-92; 428/41.7; D25/62,
D25/69, 119-124; 296/75

See application file for complete search history.

(56) **References Cited**

U.S. PATENT DOCUMENTS

D291,077 S	*	7/1987	Parno	D12/203
D302,967 S	*	8/1989	Bowdoin	D12/203
D305,323 S	*	1/1990	Anderson et al.	D12/203
D318,039 S	*	7/1991	Flores	D12/203
D324,668 S	*	3/1992	Anderson	D12/203
D424,006 S	*	5/2000	Lemieux et al.	D12/203
D495,283 S	*	8/2004	Ashley et al.	D12/203
D497,338 S	*	10/2004	Metros et al.	D12/203
D513,398 S	*	1/2006	Kozak et al.	D12/203
D535,928 S	*	1/2007	Crandall	D12/203

OTHER PUBLICATIONS

Mid-America Automotive Products, Inc. ("MAAP"); "Product Catalog 2005"; catalog; 2005; 12 pages; MAAP; Sapulpa, OK.
Christian Vila Kuid; "AE 510, Research Project 1 Cold Extrusion"; research project; Oct. 22, 2002; 14 pages; http://www.engr.ku.edu/~rhale/ae510/websites_f02/extrusion.doc.

* cited by examiner

Primary Examiner—Stacia Cadmus

(74) *Attorney, Agent, or Firm*—Howison & Arnott, L.L.P.

(57) **CLAIM**

The ornamental design for a step rail for a vehicle, as shown and described.

DESCRIPTION

FIG. 1 is a perspective view of a step rail for a vehicle showing one embodiment of my new design;

FIG. 2 is a front elevation view thereof;

FIG. 3 is a right end view thereof;

FIG. 4 is a left end view thereof;

FIG. 5 is a rear elevation view thereof;

FIG. 6 is a top plan view thereof;

FIG. 7 is a bottom plan view thereof;

FIG. 8 is an enlarged cross-sectional view thereof taken along line 8—8 of FIG. 1, and further is an enlarged cross-sectional view of the embodiment of FIG. 9 taken along line 8—8 of FIG. 9;

FIG. 9 is a perspective view of a step rail for a vehicle showing another embodiment of my new design;

FIG. 10 is a front elevation view thereof;

FIG. 11 is a right end view thereof;

FIG. 12 is a left end view thereof;

FIG. 13 is a rear elevation view thereof;

FIG. 14 is a top plan view thereof; and,

FIG. 15 is a bottom plan view thereof.

The broken line showing of mounting brackets in FIGS. 1 and 9 are for illustrative purposes only and form no part of the claimed design.

The step rail is shown broken away in FIGS. 9-10 and 13-15 to indicate indeterminate length.

1 Claim, 4 Drawing Sheets

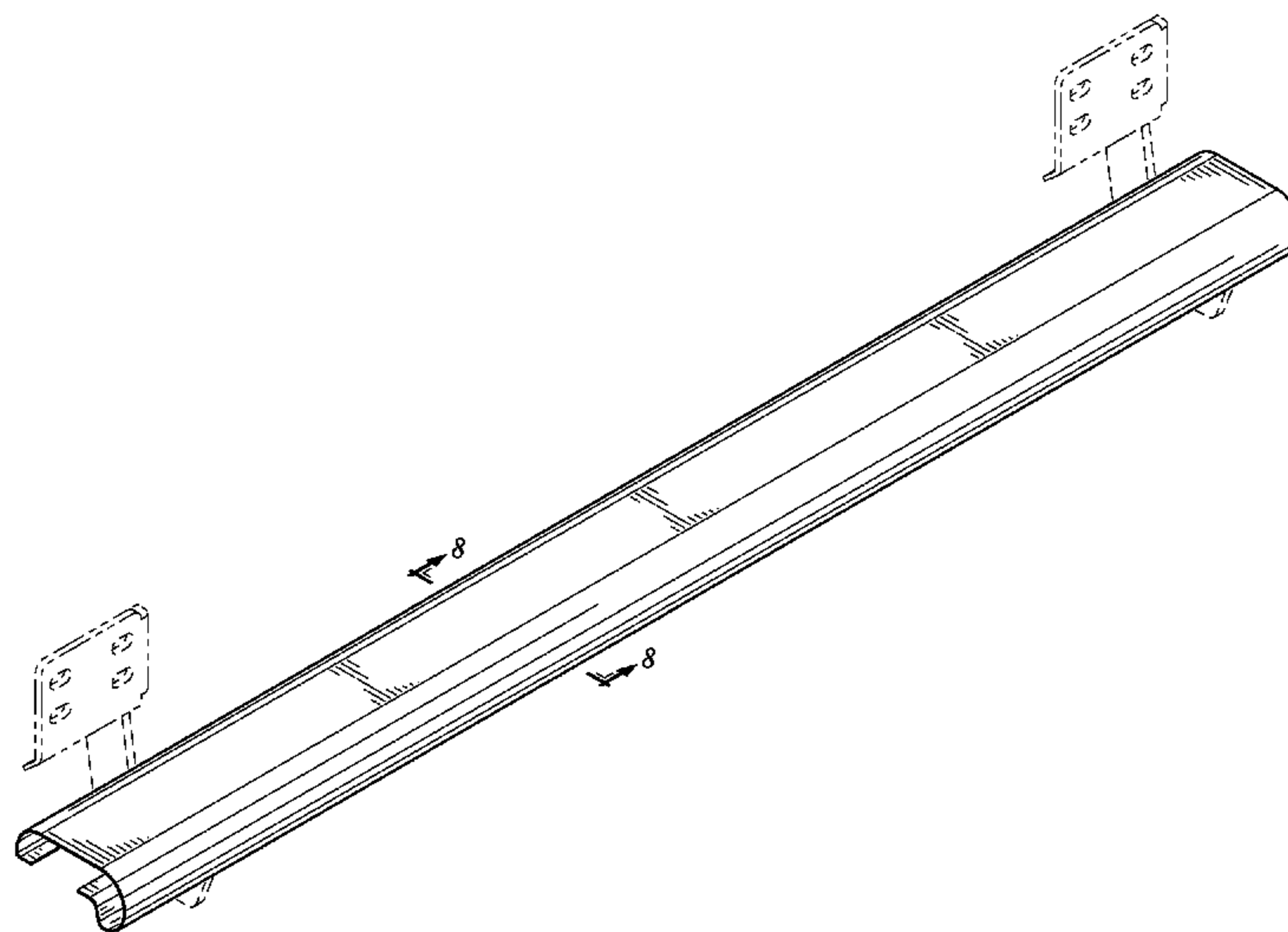

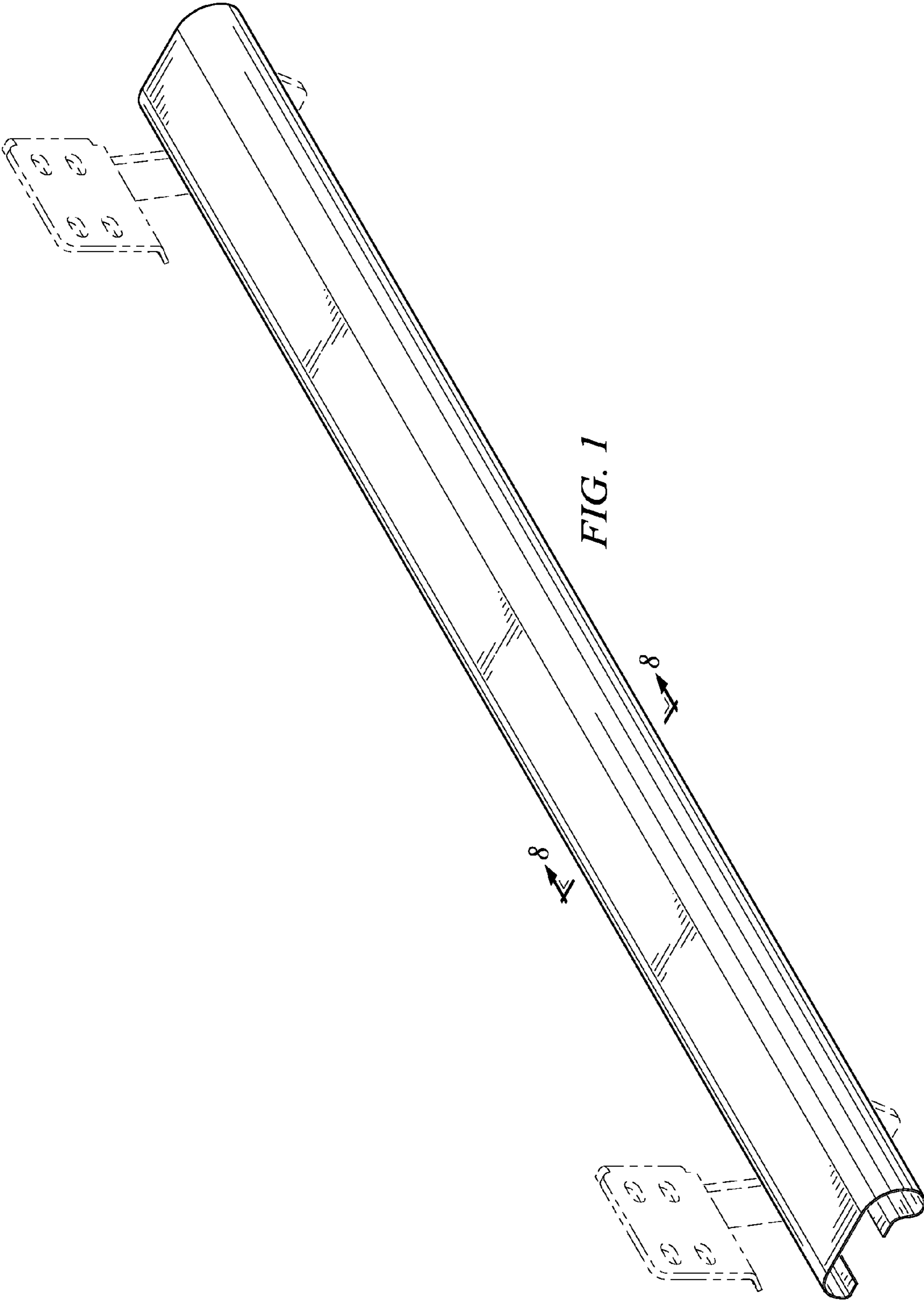

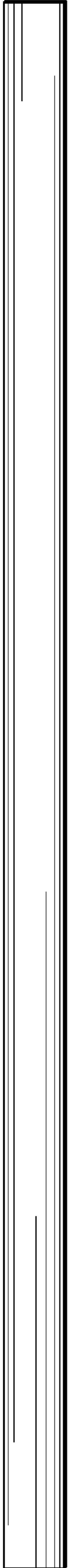

FIG. 2

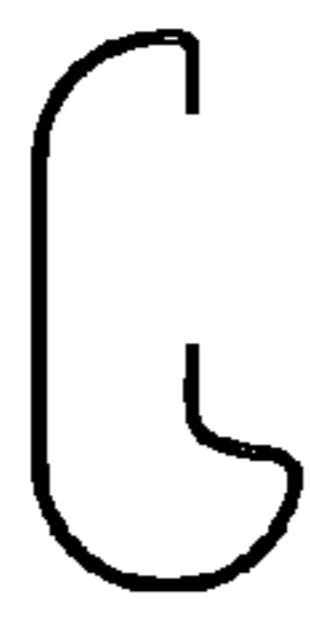

FIG. 3

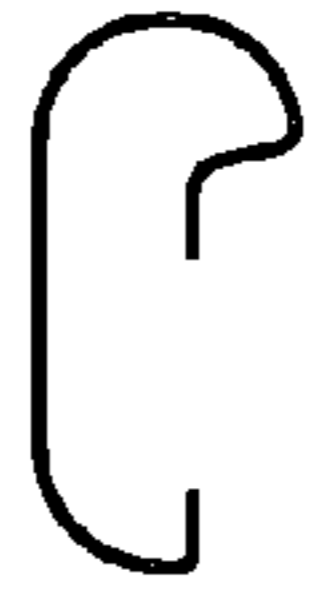

FIG. 4



FIG. 5

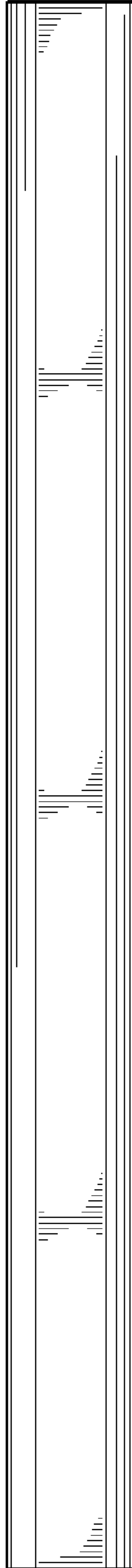

FIG. 6

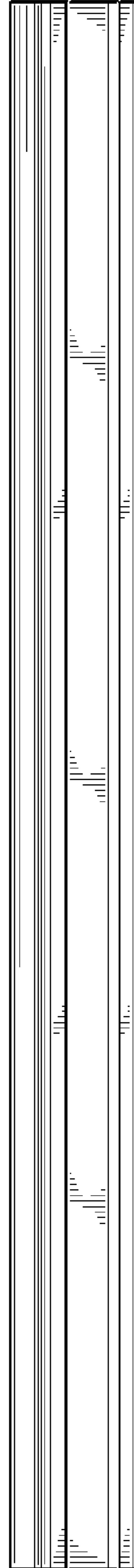

FIG. 7

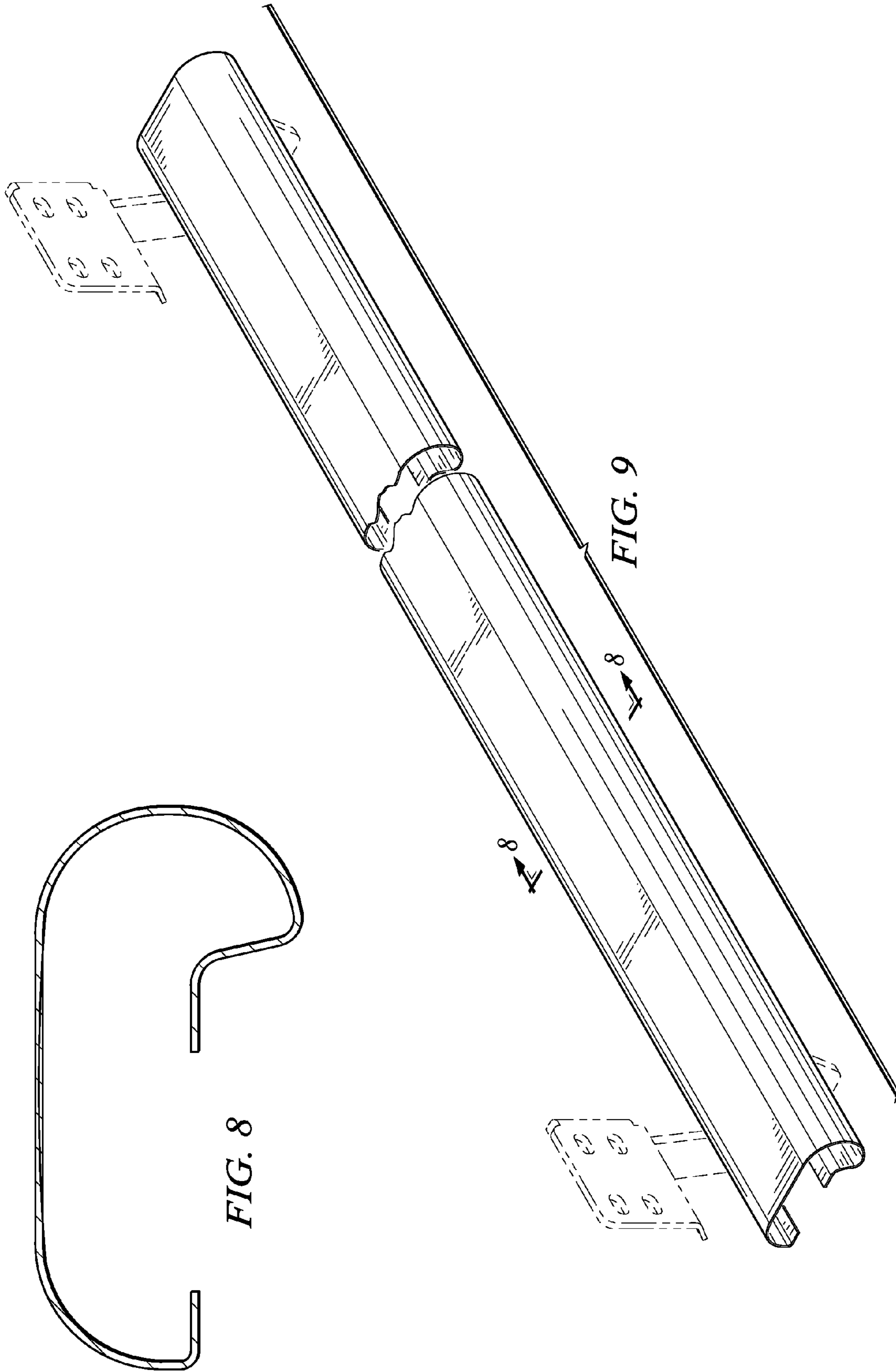

FIG. 8

FIG. 9

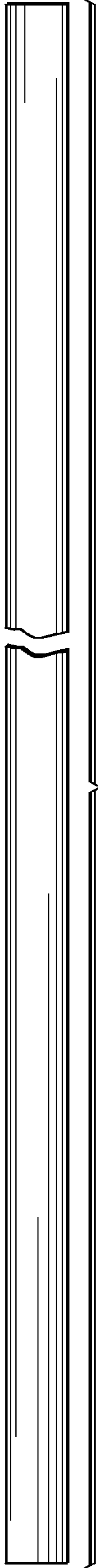

FIG. 10

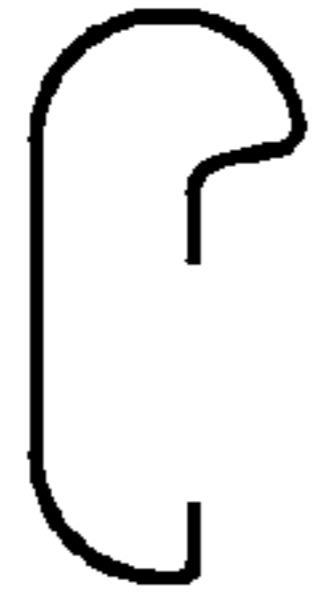

FIG. 11

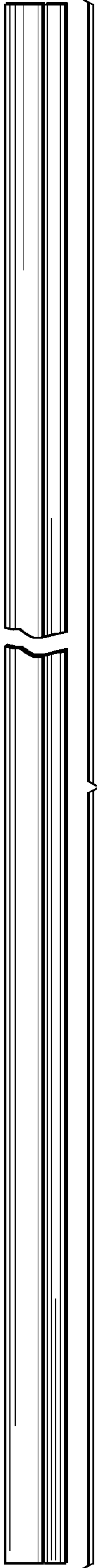

FIG. 13

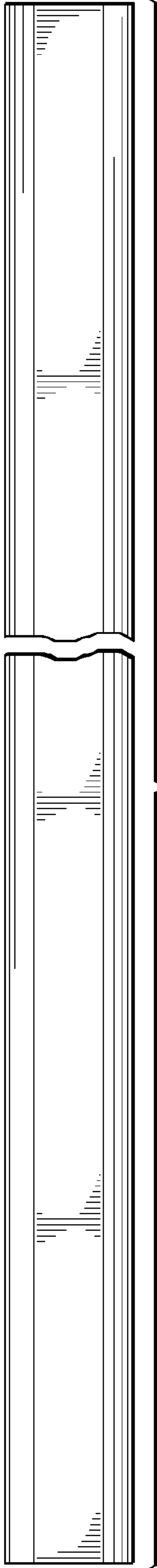

FIG. 14

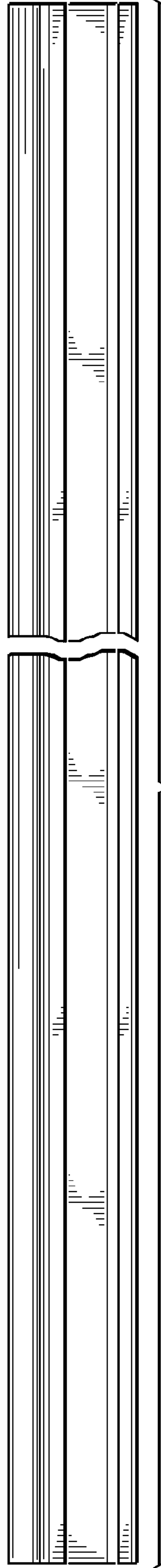

FIG. 15