

US00D567716S

(12) **United States Design Patent**  
**Shimokawa et al.**

(10) **Patent No.:** **US D567,716 S**

(45) **Date of Patent:** **\*\* Apr. 29, 2008**

(54) **REAR PART OF A MOTORCYCLE**

*Primary Examiner*—Cathron Brooks

*Assistant Examiner*—Linda Brooks

(75) Inventors: **Hiroshi Shimokawa**, Tokyo (JP);  
**Takuya Nakamura**, Tokyo (JP)

(74) *Attorney, Agent, or Firm*—Ostrolenk, Faber, Gerb & Soffen, LLP

(73) Assignee: **Yamaha Hatsudoki Kabushiki Kaisha**  
(JP)

(57) **CLAIM**

(\*\*) Term: **14 Years**

The ornamental design for a rear part of a motorcycle, as shown and described.

(21) Appl. No.: **29/276,962**

**DESCRIPTION**

(22) Filed: **Feb. 9, 2007**

(51) **LOC (8) Cl.** ..... **12-11**

(52) **U.S. Cl.** ..... **D12/110**

(58) **Field of Classification Search** ..... D12/110,  
D12/126, 182, 186; D26/28-36; 362/459-468,  
362/473-478, 485-487, 327-340; 180/219,  
180/220, 225; 296/78.1, 192, 193.01, 193.05,  
296/193.08, 193.09

See application file for complete search history.

FIG. 1 is a front, left side perspective view of a rear part of a motorcycle showing our new design, with the broken lines showing other portions of a motorcycle forming no part of the claimed design;

FIG. 2 is a rear, right side perspective view thereof;

FIG. 3 is a right side view thereof;

FIG. 4 is a left side view thereof;

FIG. 5 is a front side view thereof;

FIG. 6 is a rear view thereof;

FIG. 7 is a top view thereof; and,

FIG. 8 is a bottom view thereof.

The broken line showing of other portions of a motorcycle are for the purposes of illustrating the environmental material and form no part of the claimed design.

(56) **References Cited**

U.S. PATENT DOCUMENTS

D464,448 S	*	10/2002	Kokubu	.....	D26/28
D518,203 S	*	3/2006	Phillips et al.	.....	D26/28
D523,980 S	*	6/2006	Ito et al.	.....	D26/28
D538,955 S	*	3/2007	Katagiri et al.	.....	D26/28

\* cited by examiner

**1 Claim, 4 Drawing Sheets**

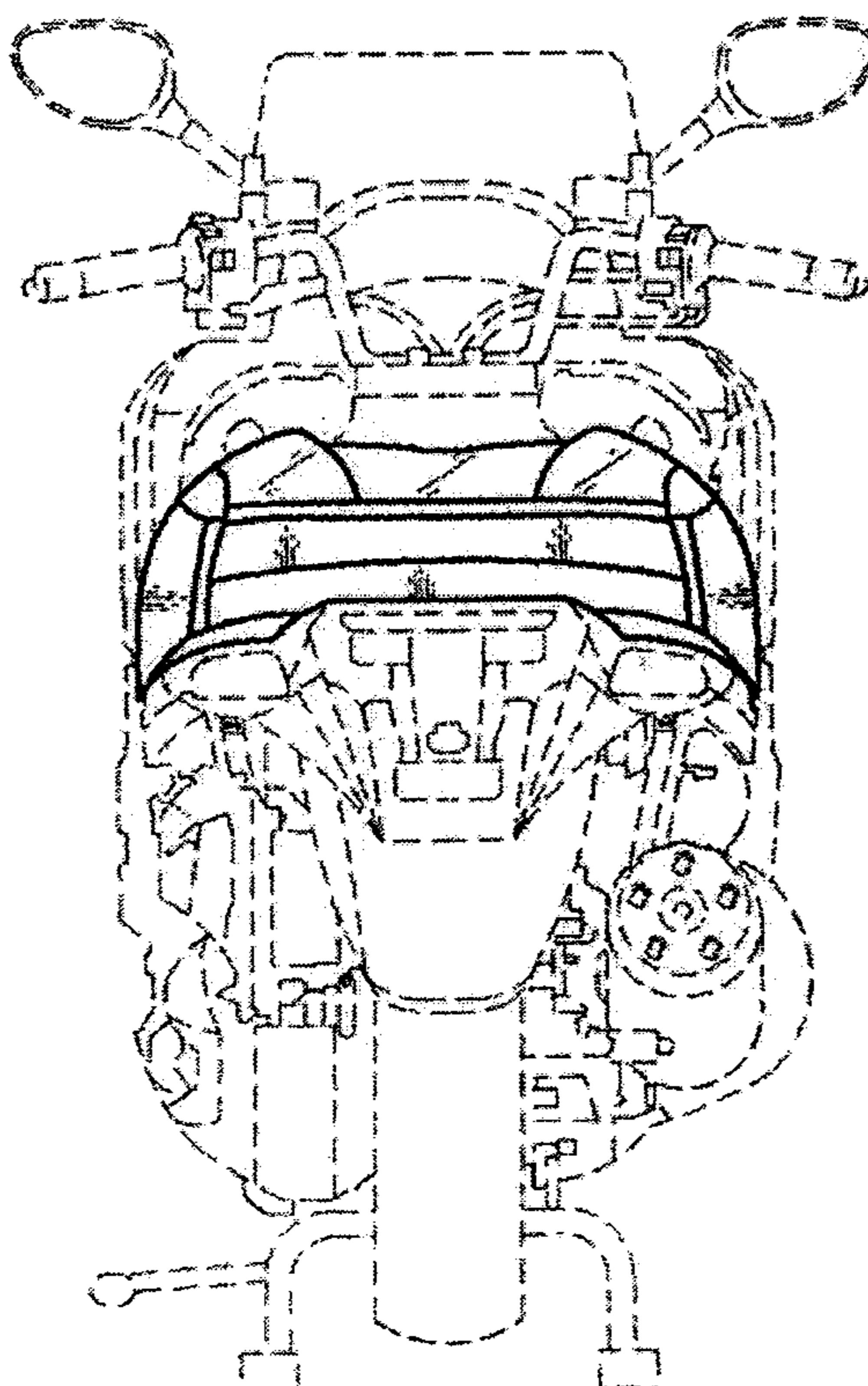

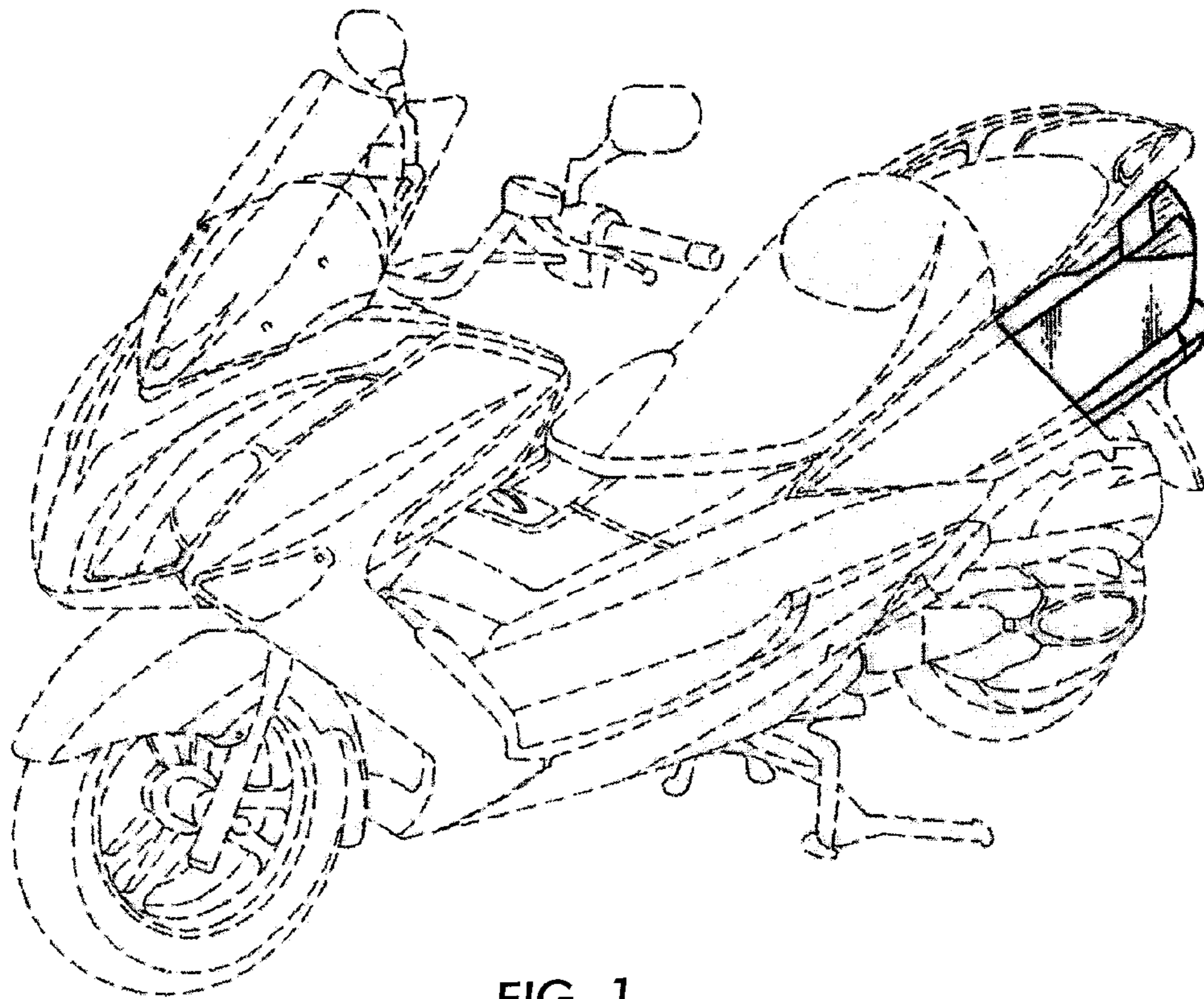

FIG. 1

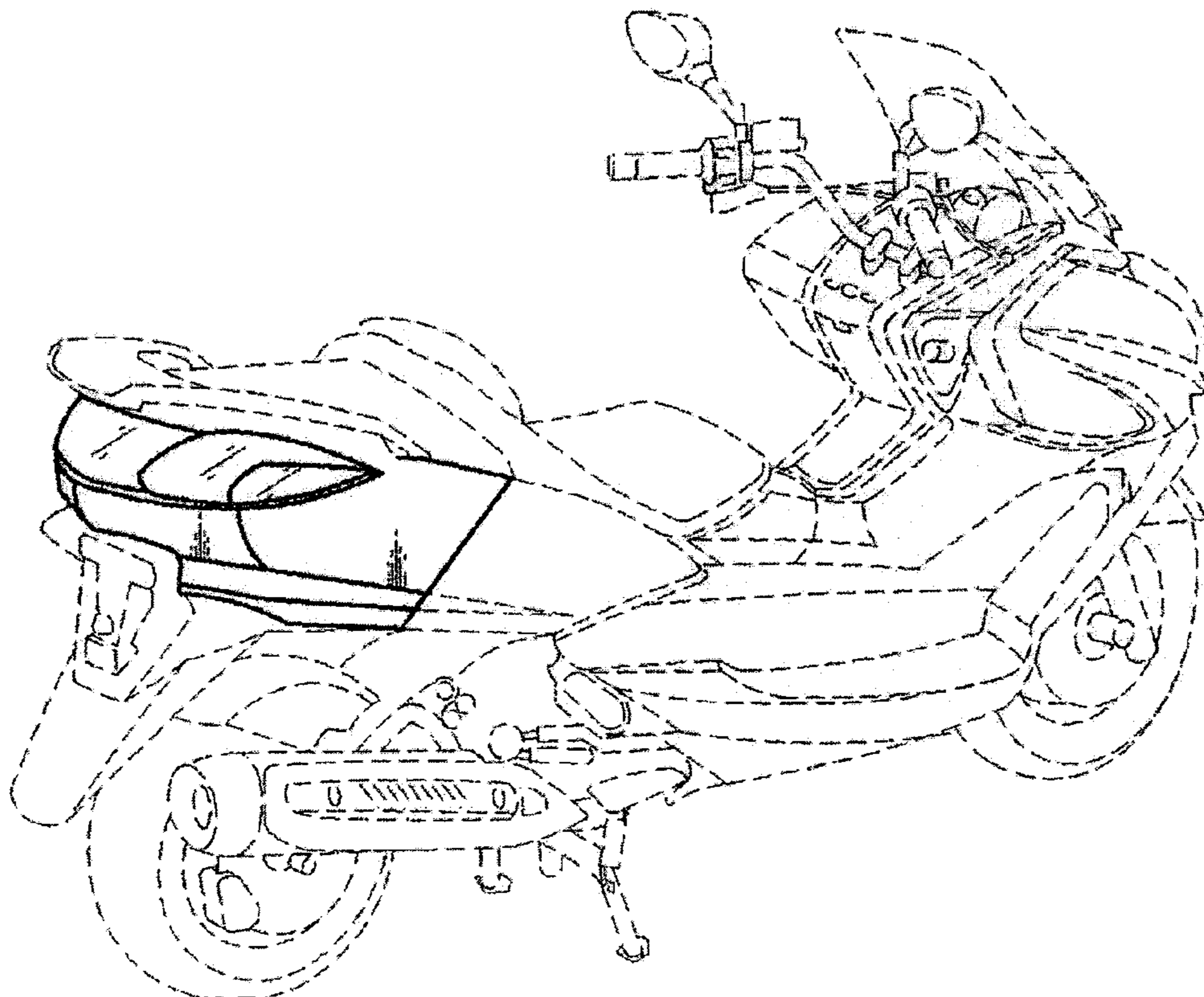

FIG. 2



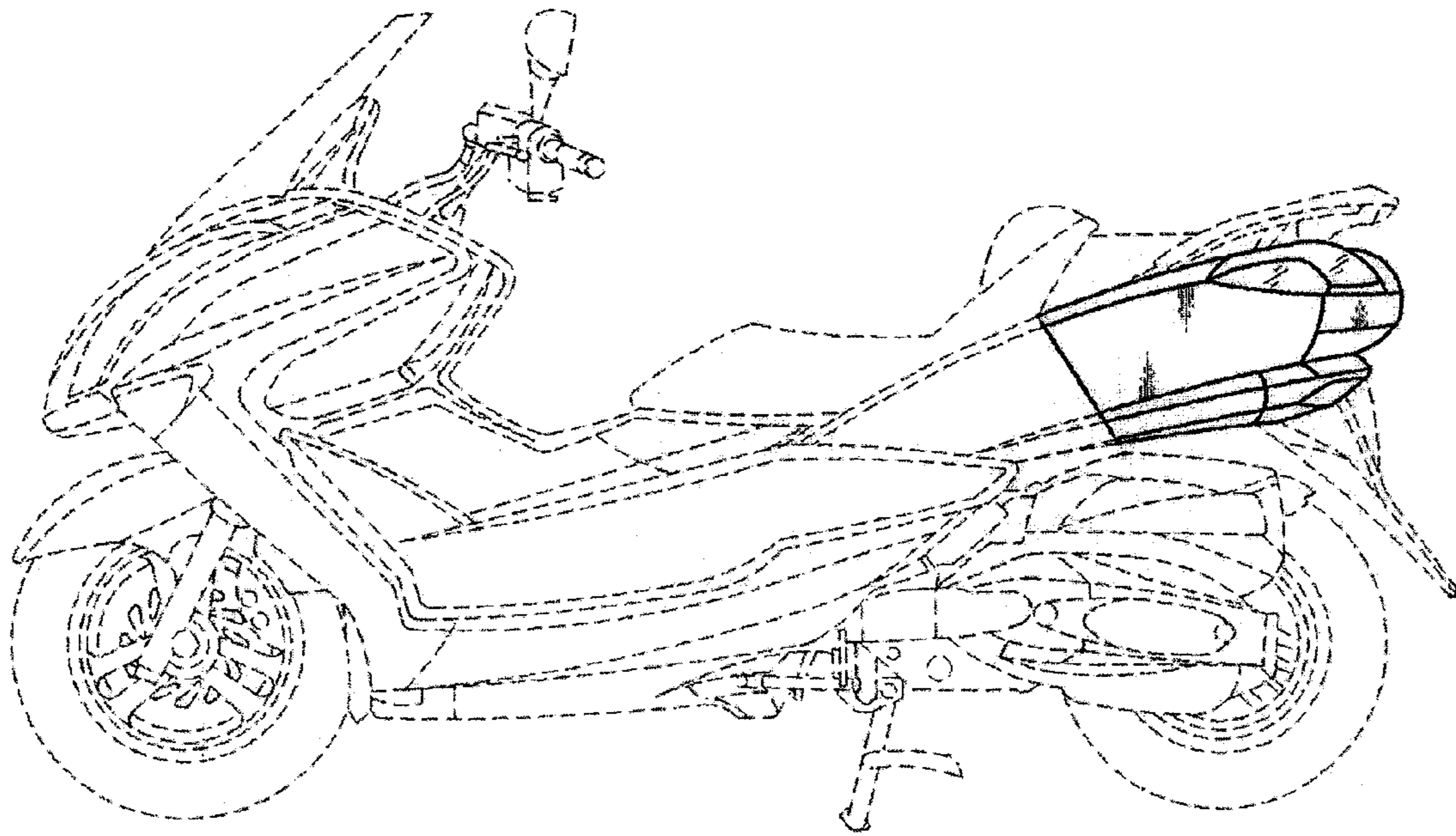

FIG. 4

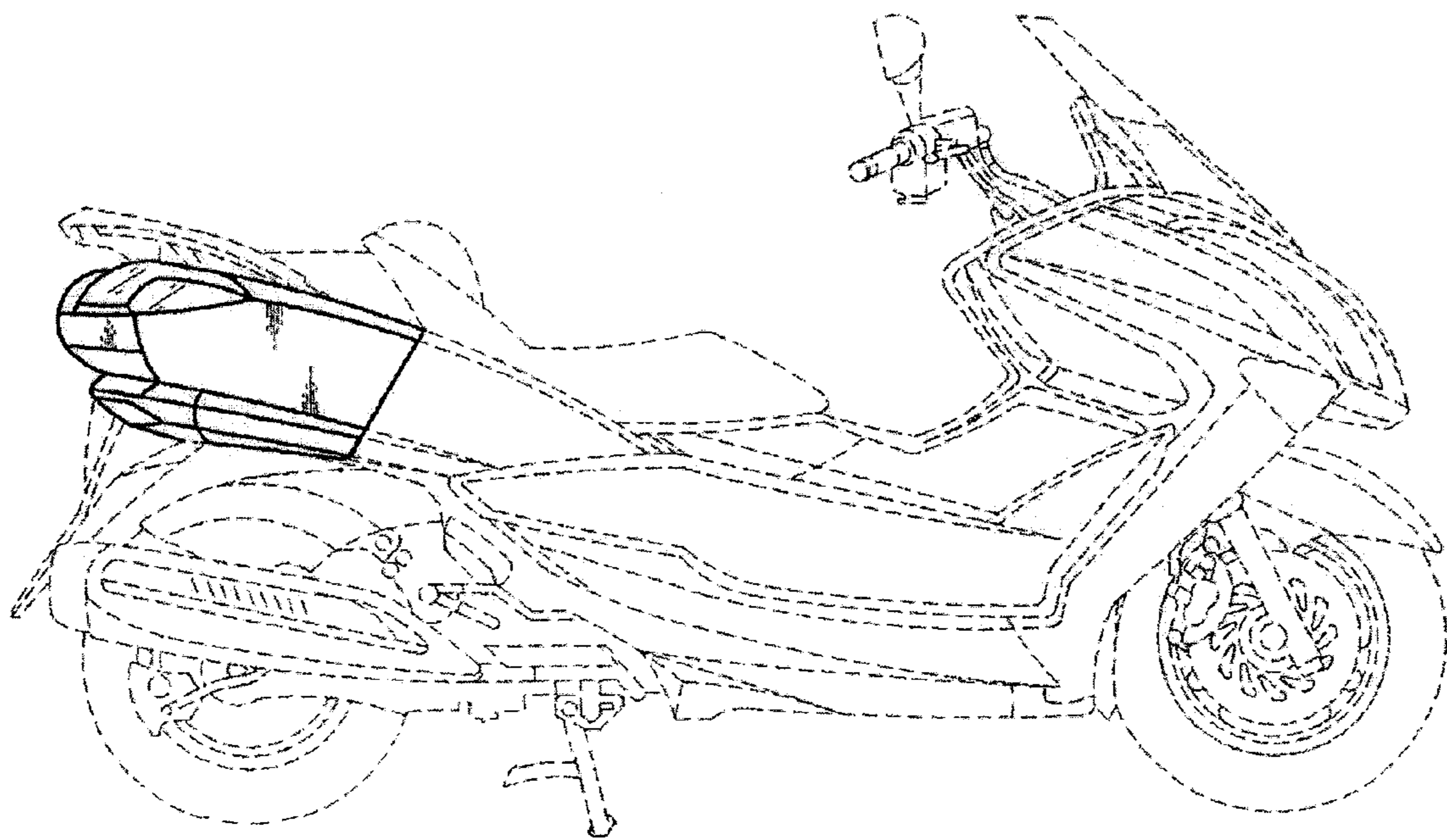

FIG. 3

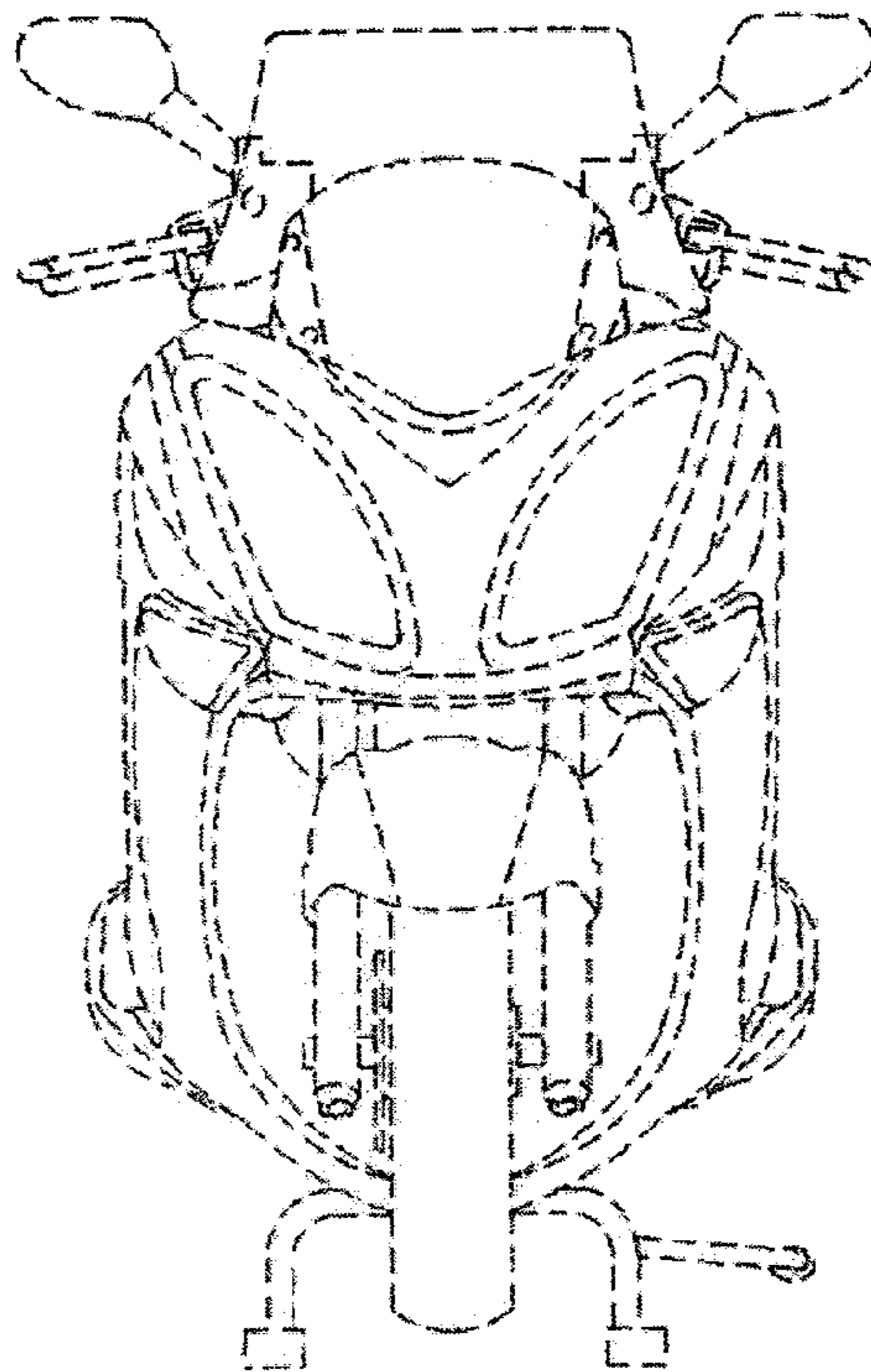

FIG. 5

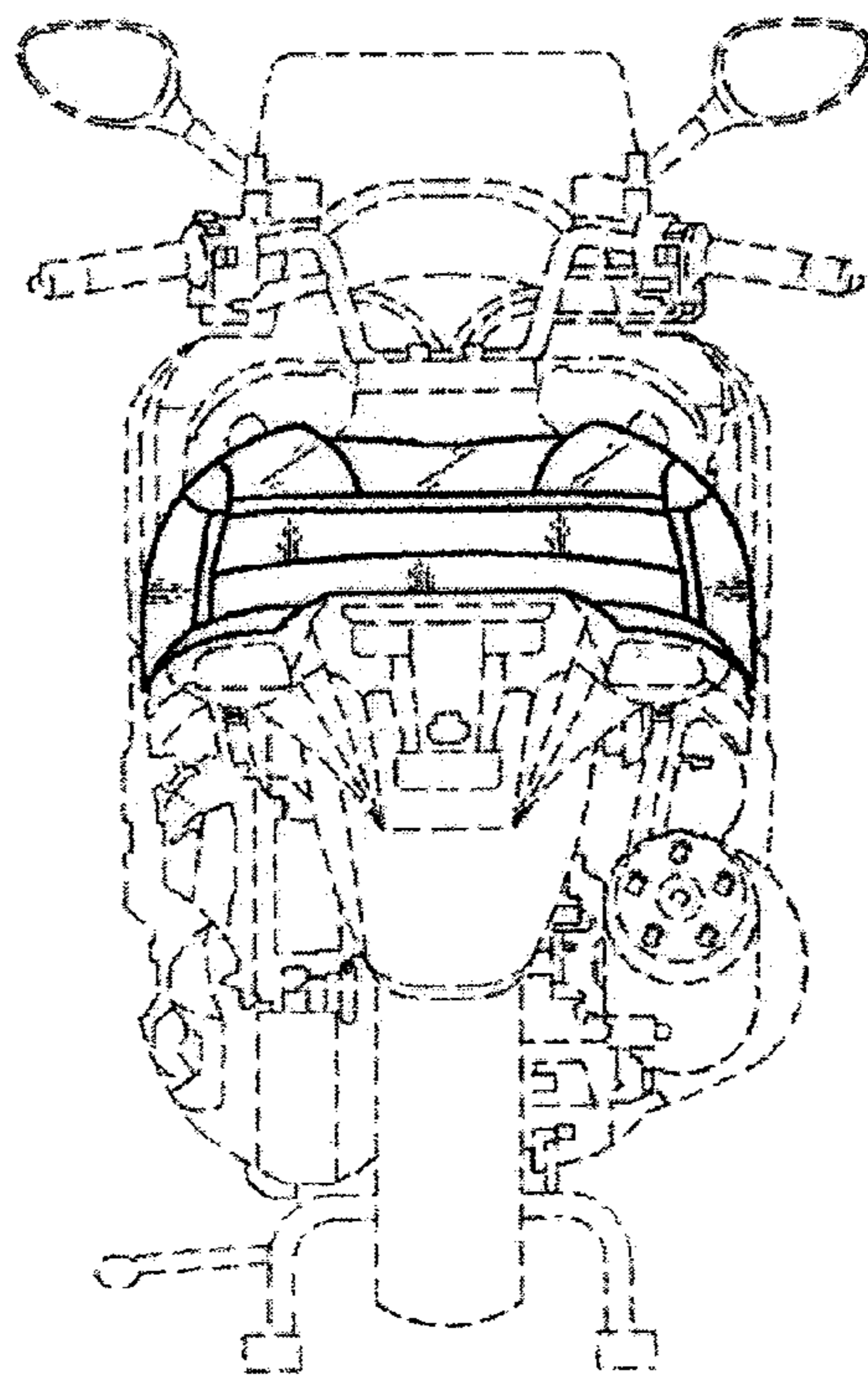

FIG. 6

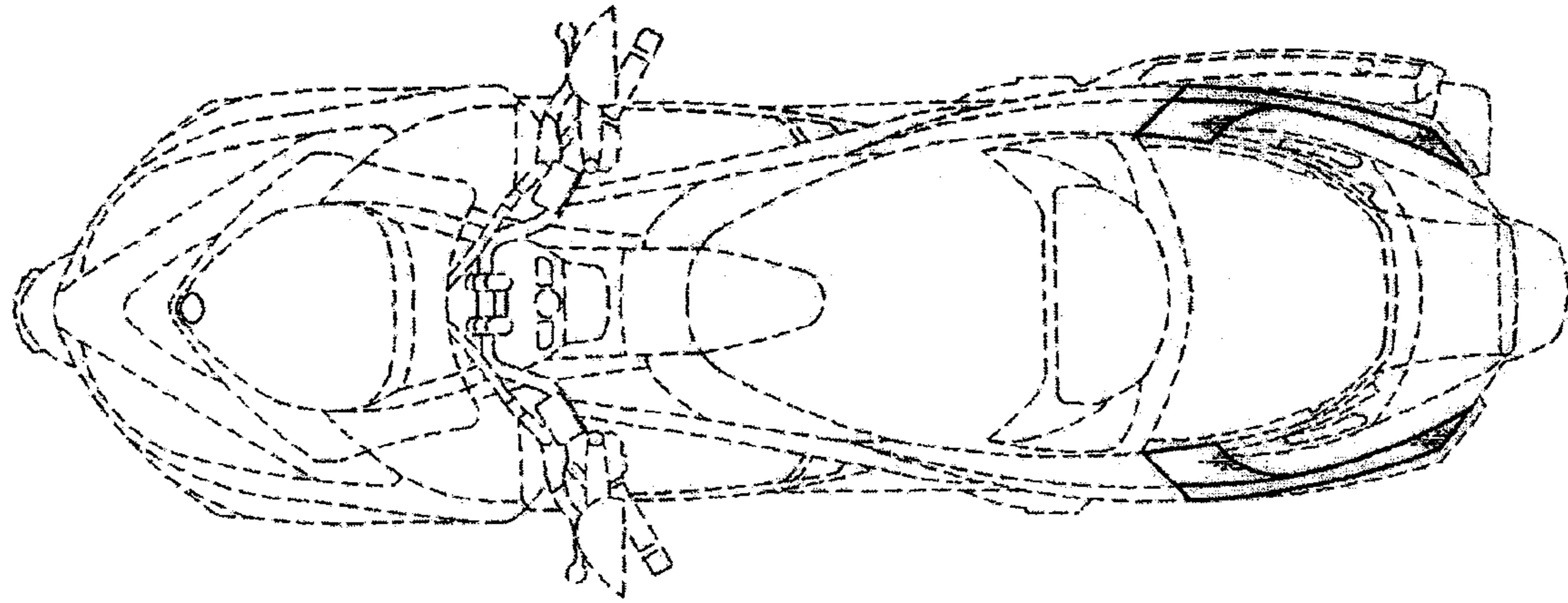

FIG. 7

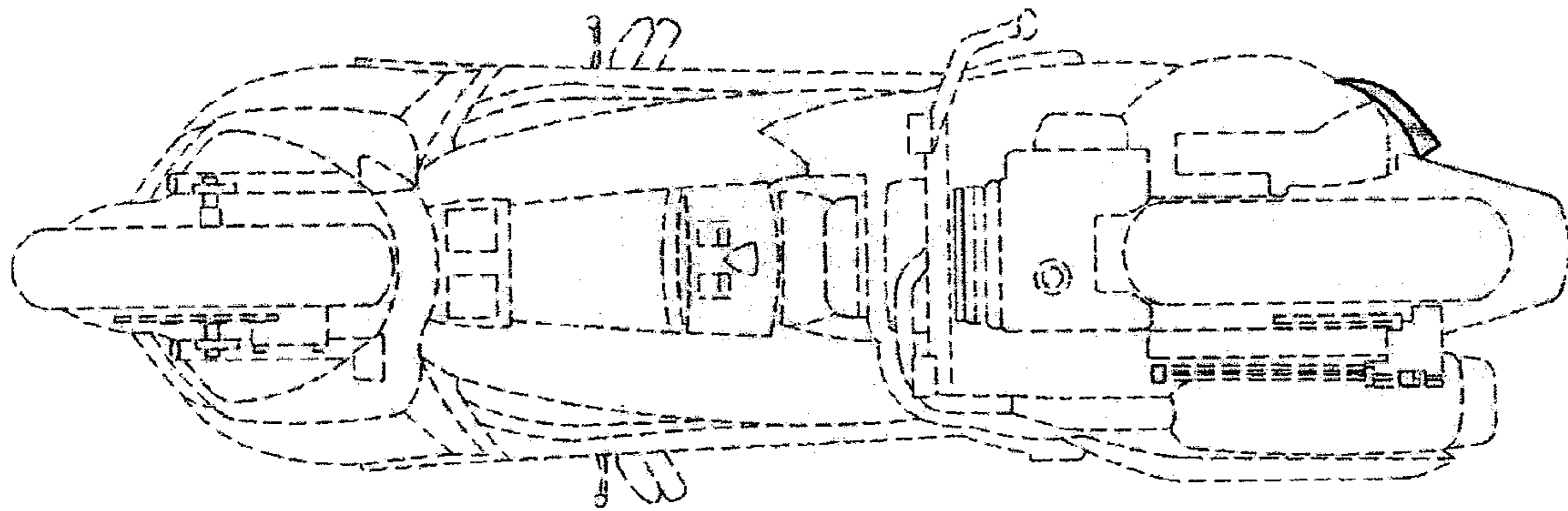

FIG. 8